

FARR

TECHNICAL MANUAL

KT (LW)13625

13-5/8" (34.6cm) 35K (25K) Lbs-Ft
Hydraulic Power Tong & FARR® Backup

- *Specifications*
- *Operation*
- *Maintenance*
- *Assembly*



CE

This technical manual covers the following models:

OVERALL MODEL	TONG MODEL	BACKUP MODEL	REV	DESCRIPTION
80-0935-4	80-0931-3	85-0900	0	13-5/8" KT Tong, 13-5/8" FARR® Backup, motor valve, backup valve, lift cylinder valve, safety door.
80-0935-5	80-0931-9	85-0900	1	13-5/8" KT Tong, 13-5/8" FARR® Backup, motor valve, backup valve, lift cylinder valve, safety door. Closed-centre system.
80-0912-1	80-0931-3-LW	85-0900	0	13-5/8" LW Tong, 13-5/8" FARR® Backup, motor valve, backup valve, lift cylinder valve, safety door.

PATENTED & PATENTS PENDING

This technical manual applies to all CE-marked versions of the models listed in the table above.

NOTE: Some illustrations used in this manual may not exactly match your model of tong.

ORIGINAL INSTRUCTIONS



***This page intentionally
left blank***

WARNINGS

A "LOAD-BEARING DEVICE" IS A CHAIN SLING, RIGID SLING, SPREADER BAR ASSEMBLY, FRAME, OR ANY OTHER DEVICE THAT BEARS THE PARTIAL OR TOTAL WEIGHT OF THE EQUIPMENT FOR WHICH THIS MANUAL HAS BEEN PRODUCED

THE LOAD-BEARING DEVICE SUPPLIED BY MCCOY DRILLING & COMPLETIONS IS DESIGNED TO SUPPORT THE EQUIPMENT DESCRIBED IN THIS MANUAL. MCCOY DRILLING & COMPLETIONS WILL NOT GUARANTEE THE ABILITY OF THE LOAD-BEARING DEVICE TO SUPPORT ANY OTHER PART, ASSEMBLY OR COMBINATION OF PARTS AND ASSEMBLIES. MCCOY DRILLING & COMPLETIONS WILL NOT GUARANTEE THE ABILITY OF THE LOAD-BEARING DEVICE TO LIFT OR SUPPORT THE EQUIPMENT DESCRIBED IN THIS MANUAL IF THERE ARE ANY MODIFICATIONS TO THE LOAD-BEARING DEVICE, OR ANY ADDITIONS TO THE EQUIPMENT DESCRIBED IN THIS MANUAL THAT ADD WEIGHT TO THE EQUIPMENT, UNLESS SUPPLIED BY MCCOY DRILLING & COMPLETIONS.

WHEN RE-ASSEMBLING LOAD-BEARING DEVICES (CHAIN SLINGS, RIGID SLINGS, BACKUP LEGS, ETC.) NOTE THAT THE ASSOCIATED FASTENERS MUST BE TIGHTENED TO THE CORRECT TORQUE SPECIFIED FOR THAT SIZE OF FASTENER (SEE SECTION 3 - OVERHAUL). ANY THREADED FASTENER IN A LOAD-BEARING DEVICE MUST BE SECURED WITH RED OR BLUE LOCTITE™.

ANY REPLACEMENT FASTENER (BOLTS, NUTS, CAP SCREWS, MACHINE SCREWS, ETC.) USED DURING MAINTENANCE OR OVERHAUL MUST BE GRADE 8 OR EQUIVALENT UNLESS OTHERWISE SPECIFIED.



***This page intentionally
left blank***

Copyright © 2007 - 2012 McCoy Corporation, including its wholly owned subsidiaries, ("McCoy"), all rights reserved. This document is the property of McCoy and is supplied as reference information for users of our products. This document and the contents within are considered confidential information, not to be disclosed, copied, transmitted, transcribed in any form, or stored on any type of data storage media without the express written consent of McCoy.

McCoy has made every effort to ensure the information contained in this document is accurate and current. This manual is intended to provide equipment operation and safety instructions for your equipment. However, McCoy does not warrant or guarantee that the information is either complete or accurate in every respect and the user of the manual should consult with its McCoy sales representative for any clarifications and updates.

The user of the manual shall protect, indemnify, and hold harmless McCoy and its directors, officers, employees, and agents from and against all liability for personal injury, death, or property damage resulting directly or indirectly from the use of the information contained in this manual.

Observance of all descriptions, information and instructions set out in this manual is the full responsibility of the user. This manual is intended for guidance and informational purposes and must be used in association with adequate training and on-the-job supervision to provide safe and effective equipment use.

It is the responsibility of the user to conform to all regulations and requirements issued by an authority or agency which may affect the operation, safety or equipment integrity, that may overrule the content of this documentation.

The user will acknowledge and obey any general legal or other mandatory regulation in force relating to accident prevention, safety, and equipment integrity.

Summary Of Revisions					
Date	Section	Page	Description Of Revision	Approved	
Sep 2008	N/A	N/A	Initial Release	K.Isaacson	
Mar 2010	8	8.1	Changed item A description and part number	K.Duhon	
Jul 2011	All	All	Re-branded & reformatted manual	S.Hargreaves	
	All	All	Replaced all hazard, warning, & caution symbols with improved symbols & text.		
	Intro	iii	Revised list of supported models		
	1	1.3	Revised specifications to include lightweight version (if requested).		
	2	All			Moved Assembly Instructions to "Maintenance" section.
		All			Renumbered "Setup & Operation" as Section 2.
		2.6			Removed hydraulic schematic, tong without safety door (no longer supported).
		2.8-2.9			Revised hydraulic schematics
		2.13			Corrected list of available jaw die kits
		2.16			Revised section 2.F.1, "Suspension & Restraint".
		2.21			Added section 2.G.3, "Shifting Gears".
	3	All			Renumbered "Maintenance" as Section 3.
		3.1			Revised section 3.A, General Maintenance Safety Practices
		3.1			Added Section 3.C, "Preventive Maintenance Practices
		3.2			Replaced graphic Section 3.D.1, "Lubrication, Cage Plate / Guide Ring".
		3.10			Added Section 3.E.3, "Door Alignment".
		3.11			Added Section 3.E.4, "Shifter Detent Force Adjustment".
		3.12-3.13			Revised Section 3.G, "Overhaul Procedures".
		3.14-3.22			Added revised Section 3.H, "Assembly Procedures".
		3.23			Added Section I, "Daily Power Tong Inspection & Maintenance Checklist".
		3.25			Added Section J, "Daily Backup Inspection & Maintenance Checklist".
		3.26			Added Section K, "Monthly Power Tong Maintenance Checklist".
		3.29			Added Section L, "Daily Power Unit Inspection & Maintenance Checklist".
3.30		Added Section M, "Tubular Connection Equipment De-Commissioning Checklist".			
3.33		Added Section N, "Tubular Connection Equipment Re-Commissioning Checklist".			
4	All		Renumbered "Troubleshooting" as Section 4.		
			Deleted Section, "Storage Recommendations" (see Sections 3.M & 3.N).		
Continued on next page					

Summary Of Revisions Continued				
Date	Section	Page	Description Of Revision	Approved
Jul 2011	5	All	Renumbered "Assemblies & Parts" as Section 5.	SHargreaves
		5.2-5.3	Revised graphics & BOM, "Gear Train Layout".	
		5.30-5.31	Added graphic & BOM, "Cage Plate Assembly (Lightweight Tong)".	
	6	All	Renumbered "Torque Measurement" as Section 6.	
		All	Complete revision of torque measurement section	
OCT 2011	5		Checked & corrected part numbers for fasteners where necessary - all B.O.M.s in Section 5	DBowles
SEP2012	Intro	xii	Inserted List of Illustrations	SPanchal
		xiv	Added CE Marked modifier statement and identification symbol	
	1	1.2	Corrected dimensions, added hazard and "safe-to-handle" legend	
		1.3	Inserted illustration of additional hazard areas	
		1.4	Inserted illustration & identification of FARR CE Nameplate	
		1.5-1.6	Corrected specifications	
	2	2.1	Inserted new section "Initial Receipt & Inspection of Equipment"	
		2.4	Renumbered section 2.C, "Sling & Load-Bearing Device Safety"	
		2.7	Inserted new section 2.D, "Lift Cylinder Installation"	
		2.10	Renumbered section 2.E, "Hydraulics"	
		2.12 - 2.13	Inserted CE-applicable hydraulic schematics	
		2.16	Moved section "Hydraulic Connections" into Section 2.E, Hydraulics.	
		2.17	Inserted new subsection 2.E.4, "Hydraulic Circuit Description"	
		2.18	Renumbered and revised section 2.F, "Tong Jaw Availability & Installation". Added CE-specific information.	
		2.22	Renumbered section 2.G, "Tong Rig-Up & Leveling"	
		2.25	Renumbered section 2.H, "Tong Operation"	
		2.25	Inserted new subsection 2.H.1, "Operator Training"	
		2.25	Inserted new subsection 2.H.2, "Operator Safety"	
			Removed subsection "Initial Startup & Break-in Procedure"	
		2.25	Renumbered and revised subsection 2.H.3, "Valve Operation"	
		2.26	Added CE-specific information to lift cylinder valve operation	
	2.27	Renumbered subsection 2.H.4, "Shifting Gears"		
	2.28	Inserted new subsection 2.H.5, "Pre-Operational Checks"		
	2.29	Renumbered subsection 2.H.6, "General Comments"		
	2.40	Renumbered section 2.I, "Extreme Cold Weather Operations"		
	2.32	Inserted new section 2.J, "Making and Breaking Connections"		
	3	3.2	Inserted new section 3.D, "Hydraulic System De-Pressurization"	
		3.2	Renumbered section 3.E, "Lubrication Instructions"	
		3.9	Renumbered section 3.F, "Adjustments"	
		3.9	Revised subsection 3.F.1, "Brake Band Adjustment"	
		3.10	Replaced illustration, subsection 3.F.2, "Door Latch Cam Adjustment"	
		3.12	Inserted new subsection 3.F.5, "Safety Door Adjustment"	
		3.13	Renumbered section 3.G, "Recommended Periodic Checks"	
3.14	Renumbered & revised section 3.H, Overhaul Procedures - Disassembly. Corrected disassembly procedures and added CE-specific information and warnings.			
Continued on next page				

Summary Of Revisions Continued						
Date	Section	Page	Description Of Revision	Approved		
SEP2012	3	3.16-3.29	Renumbered & revised section 3.1, Assembly Procedures. Corrected assembly procedures and added CE-specific information and warnings.	SPanchal		
		3.30	Renumbered Section 3.J "Daily Inspection & Maintenance Checklist (Power Tong)". Added CE-Specific information.			
		3.32	Renumbered Section 3.K "Daily Inspection & Maintenance Checklist (Backups)".			
		3.33	Renumbered Section 3.L "Monthly Inspection & Maintenance Checklist (Power Tong)".			
		3.36	Renumbered Section 3.M "Tubular Connection Equipment De-Commissioning". Revised section to add packaging and shipping instructions and retitled "Tubular Connection Equipment De-Commissioning & Shipping".			
		3.41	Renumbered Section 3.N "Tubular Connection Equipment Re-Commissioning".			
	4	4.1	Revised section 4.A, Troubleshooting - Tong Will Not Develop Sufficient Torque			
		4.2	Inserted new section 4.B, Troubleshooting - Relief Valve			
		4.4	Inserted new section 4.C, Troubleshooting - Safety Door			
		4.5	Renumbered section 4.D, Troubleshooting - Tong Running Too Slowly			
		4.6	Renumbered section 4.E, Troubleshooting - Failure of Jaws to Grip Pipe			
		4.7	Renumbered section 4.F, Troubleshooting - Shifting			
	5	5.2	Inserted list of critical spare parts			
		5.3	Inserted list of recommended spare parts			
		5.4	Inserted list of parts needed for complete overhaul			
			Removed Images and B.O.M.s, "Tong Body Assembly"			
		5.22 - 5.23	Inserted new illustration & B.O.M., Hydraulic Valve Assembly Supports			
		5.26 - 5.27	Replaced illustration & updated B.O.M., Motor Mount Assembly			
		5.30 - 5.31	Replaced illustration & updated B.O.M., Cage Plate Assembly (KT13625)			
		5.33	Updated B.O.M., Cage Plate Assembly (LW13625)			
		5.37	Added addition B.O.M. for CE-specific components, Tong Safety Door			
		5.38-5.39	Replaced illustration & revised B.O.M., Rigid Sling. Added addition illustration and updated B.O.M. to show CE-specific components.			
	5.40 - 5.41	Replaced illustration & updated B.O.M., Leg Assemblies				
		5.44 - 5.45	Replaced illustration & updated B.O.M., Backup Rotary Assembly			
	6	6.1	Revised section 6.A, Basic Torque Measurement			
		6.2	Added parts information for metric torque measurement assembly			
		6.6	Inserted subsection 6.C.3, Reference Checking Torque Measurement System			
	AUG2013	1	1.5		Corrected arm length and maximum rigid sling load in specifications	DBowles

SECTION ONE: INTRODUCTION

Introduction & Contact Information..... 1.1
 Equipment Specifications..... 1.2
 Lubricant Specifications 1.6

SECTION TWO: SETUP & OPERATION

A. INITIAL RECEIPT AND INSPECTION OF EQUIPMENT..... 2.1
 B. MAJOR COMPONENT IDENTIFICATION..... 2.1
 C. SLING / LOAD BEARING DEVICE SAFETY
 1. Inspection Of Slings..... 2.5
 2. Proper Use Of Load-Bearing Devices..... 2.6
 3. Storage Of Load-Bearing Devices..... 2.6
 D. LIFT CYLINDER INSTALLATION
 1. Installation Procedure..... 2.7
 2. Lift Cylinder Connection..... 2.8
 3. Lift Cylinder Safety..... 2.8
 E. HYDRAULICS
 1. Hydraulic Schematics..... 2.10
 2. Hydraulic Component Identification..... 2.14
 3. Main Hydraulic Connections..... 2.16
 4. Hydraulic Circuit Description..... 2.17
 F. TONG JAW AVAILABILITY & INSTALLATION
 1. Jaw Availability..... 2.18
 2. Jaw / Jaw Die Removal..... 2.19
 3. Backup Jaws..... 2.21
 G. TONG RIG-UP & LEVELING
 1. Suspension & Restraint..... 2.22
 2. Tong Leveling..... 2.22
 3. Load Cell Configuration..... 2.24
 H. TONG OPERATION
 1. Operator Training..... 2.25
 2. Operator Safety..... 2.25
 3. Valve Operation..... 2.25
 4. Shifting Gears..... 2.27
 5. Pre-Operational Checks..... 2.28
 6. General Operational Comments..... 2.29
 I. EXTREME COLD WEATHER OPERATION PROCEDURES..... 2.29
 J. MAKING AND BREAKING CONNECTIONS
 1. Making A Connection..... 2.30
 2. Breaking Out A Connection..... 2.37

SECTION THREE: MAINTENANCE

A. GENERAL MAINTENANCE SAFETY PRACTICES..... 3.1
 B. CLEANING..... 3.1
 C. PREVENTIVE MAINTENANCE PRACTICES..... 3.1
 D. HYDRAULIC SYSTEM DE-PRESSURIZATION..... 3.2
 E. LUBRICATION..... 3.2
 F. ADJUSTMENTS
 1. Brake Band Adjustment:..... 3.9
 2. Door Latch Adjustment..... 3.10
 3. Door Alignment..... 3.11
 4. Shifter Detent Force Adjustment:..... 3.12
 5. Safety Door Adjustment:..... 3.12
 G. RECOMMENDED PERIODIC CHECKS
 1. Door Stop Spring..... 3.13
 2. Shifting Shaft..... 3.13
 3. Backing Pin..... 3.13
 4. Torque Gauge Assembly..... 3.13
 H. OVERHAUL PROCEDURES..... 3.14
 I. ASSEMBLY PROCEDURES..... 3.16
 J. DAILY INSPECTION & MAINTENANCE CHECKLIST (POWER TONG)..... 3.30
 K. DAILY INSPECTION & MAINTENANCE CHECKLIST (BACKUPS)..... 3.32
 L. MONTHLY MAINTENANCE CHECKLIST - POWER TONG..... 3.33
 M. TUBULAR CONNECTION EQUIPMENT DE-COMMISSIONING & SHIPPING..... 3.36
 N. TUBULAR CONNECTION EQUIPMENT RE-COMMISSIONING PROCEDURE..... 3.41

Continued on next page...

SECTION FOUR: TROUBLESHOOTING

A. TONG WILL NOT DEVELOP SUFFICIENT TORQUE..... 4.1
 B. RELIEF VALVE IS INCORRECTLY SET OR NOT FUNCTIONING..... 4.2
 C. SAFETY DOOR DOES NOT OPERATE OR IS MALFUNCTIONING..... 4.4
 D. TONG RUNNING TOO SLOWLY..... 4.5
 E. FAILURE OF JAWS TO GRIP PIPE..... 4.6
 F. FAILURE OR DIFFICULTY OF TONG TO SHIFT..... 4.7
 G. GENERAL COMMENTS..... 4.8

SECTION FIVE: PARTS AND ASSEMBLIES

Critical Spare Parts List..... 5.2
 Recommended Spare Parts List..... 5.3
 Parts List - Complete Overhaul..... 5.4
 Gear Train Layout..... 5.6
 Support Roller Assembly..... 5.8
 Door Pivot Support Roller..... 5.10
 Rotary Idler..... 5.12
 Pinion Idler..... 5.14
 Pinion Assembly..... 5.16
 Clutch Assembly..... 5.18
 Shifting Assembly..... 5.20
 Supports - Hydraulic Assembly..... 5.22
 Brake Band Assembly..... 5.24
 Motor & Motor Mount..... 5.26
 Hydraulic Assembly..... 5.28
 Cage Plate Assembly (KT13625)..... 5.30
 Cage Plate Assembly (LW13625)..... 5.32
 Tong Door Assembly..... 5.34
 Safety Door Components..... 5.36
 Rigid Sling Assemblies..... 5.38
 Leg Assemblies..... 5.40
 FARR® Backup..... 5.42
 FARR® Backup Rotary Assembly..... 5.44

SECTION SIX: TORQUE MEASUREMENT

A. BASIC TORQUE MEASUREMENT..... 6.1
 B. TROUBLESHOOTING..... 6.5
 C. PERIODIC INSPECTION AND MAINTENANCE
 1. Inspection..... 6.6
 2. Fluid Recharge..... 6.6
 3. Reference Checking The Torque Measurement System..... 6.6
 4. Repair And Calibration..... 6.7

SECTION SEVEN: HYDRAULIC COMPONENT INFORMATION

ILLUSTRATION 1.A.1: KT13625 TONG & FARR® BACKUP (MODEL 80-0935-4 SHOWN)	1.1
ILLUSTRATION 1.A.2: KT13625 TONG & FARR® BACKUP DIMENSIONS.....	1.2
ILLUSTRATION 1.A.3: KT13625 TONG & FARR® BACKUP HAZARD AREAS (CE-MARKED MODEL SHOWN)	1.3
ILLUSTRATION 1.A.4: FARR® CE NAMEPLATE	1.4
ILLUSTRATION 2.B.1: KT13625 TONG & FARR® BACKUP MAJOR COMPONENT IDENTIFICATION 01	2.1
ILLUSTRATION 2.B.2: KT13625 TONG & FARR® BACKUP MAJOR COMPONENT IDENTIFICATION 02	2.2
ILLUSTRATION 2.B.3: KT13625 TONG & FARR® BACKUP MAJOR COMPONENT IDENTIFICATION 03	2.3
ILLUSTRATION 2.C.1: SLING ANGLE.....	2.4
ILLUSTRATION 2.D.1: LIFT CYLINDER & SPRING HANGER INSTALLATION.....	2.7
ILLUSTRATION 2.D.2: LIFT CYLINDER HYDRAULIC CONNECTION	2.8
ILLUSTRATION 2.E.1: KT13625 TONG & FARR® BACKUP HYDRAULIC SCHEMATIC	2.10
ILLUSTRATION 2.E.2: KT13625 TONG & FARR® BACKUP HYDRAULIC (CLOSED CENTRE)	2.11
ILLUSTRATION 2.E.3: KT13625 TONG & FARR® BACKUP HYDRAULIC SCHEMATIC (CE MARKED)	2.12
ILLUSTRATION 2.E.4: KT13625 TONG & FARR® BACKUP HYDRAULIC (CLOSED CENTRE, CE MARKED).....	2.13
ILLUSTRATION 2.E.5: KT13625 TONG & FARR® BACKUP HYDRAULIC COMPONENT ID 01	2.14
ILLUSTRATION 2.E.6: KT13625 TONG & FARR® BACKUP HYDRAULIC COMPONENT ID 02	2.14
ILLUSTRATION 2.E.7: KT13625 TONG & FARR® BACKUP HYDRAULIC COMPONENT ID 03	2.15
ILLUSTRATION 2.E.8: KT13625 TONG & FARR® BACKUP HYDRAULIC COMPONENT ID 04	2.15
ILLUSTRATION 2.E.9: KT13625 TONG & FARR® BACKUP HYDRAULIC COMPONENT ID 05	2.16
ILLUSTRATION 2.E.10: KT13625 TONG & FARR® BACKUP HYDRAULIC CONNECTIONS 01.....	2.16
ILLUSTRATION 2.E.11: KT13625 TONG & FARR® BACKUP HYDRAULIC CONNECTIONS 02.....	2.17
ILLUSTRATION 2.F.1: JAW DIE REMOVAL	2.20
ILLUSTRATION 2.F.2: JAW REMOVAL	2.21
ILLUSTRATION 2.G.1: TONG LEVELING (SIDE-TO-SIDE)	2.23
ILLUSTRATION 2.G.2: TONG LEVELING, FRONT-TO-BACK.....	2.23
ILLUSTRATION 2.G.4: LOAD CELL CONFIGURATION, BREAK-OUT	2.24
ILLUSTRATION 2.G.3: LOAD CELL CONFIGURATION, MAKE-UP	2.24
ILLUSTRATION 2.H.1: MOTOR CONTROL VALVE	2.26
ILLUSTRATION 2.H.2: LIFT CYLINDER CONTROL VALVE	2.26
ILLUSTRATION 2.H.3: FARR® BACKUP CONTROL VALVE	2.27
ILLUSTRATION 2.H.4: SHIFTING GEARS	2.27
ILLUSTRATION 2.J.1: RIGID SLING MASTER LINK.....	2.30
ILLUSTRATION 2.J.2: SETTING BACKING PIN TO "MAKE-UP" POSITION.....	2.31
ILLUSTRATION 2.J.3: OPENING RH TONG DOOR	2.31
ILLUSTRATION 2.J.4: OPENING LH TONG DOOR.....	2.32
ILLUSTRATION 2.J.5: OPENING BACKUP DOOR	2.32
ILLUSTRATION 2.J.6: LIFT CYLINDER CONTROL - RAISE (NON CE-MARKED TONGS)	2.33
ILLUSTRATION 2.J.7: BACKUP CONTROL - CLAMP.....	2.34
ILLUSTRATION 2.J.8: MOTOR CONTROL - MAKE-UP.....	2.34
ILLUSTRATION 2.J.9: USING MOTOR CONTROL TO RELEASE JAWS IN "MAKE UP" MODE	2.35
ILLUSTRATION 2.J.11: USING LIFT CYLINDER CONTROL TO LOWER ASSEMBLY (NON CE-MARKED TONGS ONLY).....	2.36
ILLUSTRATION 2.J.10: USING BACKUP CONTROL TO RELEASE BACKUP JAWS	2.36
ILLUSTRATION 2.J.12: SETTING BACKING PIN TO BREAK-OUT POSITION	2.37
ILLUSTRATION 2.J.13: MOTOR CONTROL - BREAK OUT	2.38
ILLUSTRATION 2.J.14: USING MOTOR CONTROL TO RELEASE JAWS IN "BREAK OUT" MODE	2.39
ILLUSTRATION 3.E.1: KT13625 GUIDE RING LUBRICATION.....	3.2
ILLUSTRATION 3.E.2: LW13625 CAM FOLLOWER LUBRICATION.....	3.3
ILLUSTRATION 3.E.3: SUPPORT ROLLER BEARING LUBRICATION	3.3
ILLUSTRATION 3.E.4: ROTARY IDLER LUBRICATION	3.4
ILLUSTRATION 3.E.5: PINION IDLER LUBRICATION	3.4
ILLUSTRATION 3.E.6: PINION LUBRICATION TOP PLATE	3.5
ILLUSTRATION 3.E.7: PINION LUBRICATION BOTTOM PLATE.....	3.5
ILLUSTRATION 3.E.8: CLUTCH SHAFT LUBRICATION	3.6
ILLUSTRATION 3.E.9: SHIFTING SHAFT LUBRICATION.....	3.6
ILLUSTRATION 3.E.10: MOTOR MOUNT LUBRICATION.....	3.7
ILLUSTRATION 3.E.11: DOOR LATCH CAM LUBRICATION.....	3.7
ILLUSTRATION 3.E.12: DOOR STOP SPRING LUBRICATION	3.8
ILLUSTRATION 3.E.13: FARR® BACKUP CAM RING CAM FOLLOWER LUBRICATION	3.8

Continued on next page...

ILLUSTRATION 3.F.1: BRAKE BAND ADJUSTMENT	3.9
ILLUSTRATION 3.F.2: DOOR LATCH CAM ADJUSTMENT.....	3.10
ILLUSTRATION 3.F.3: DOOR ALIGNMENT	3.11
ILLUSTRATION 3.F.4: SHIFTER DETENT FORCE ADJUSTMENT	3.12
ILLUSTRATION 3.F.5: SAFETY DOOR SWITCH PLATE ADJUSTMENT	3.13
ILLUSTRATION 3.I.1: TONG ASSEMBLY - ROTARY GEAR INSTALLATION	3.17
ILLUSTRATION 3.I.2: TONG ASSEMBLY - GEAR ASSEMBLY POSITIONING	3.18
ILLUSTRATION 3.I.3: TONG ASSEMBLY - TOP PLATE FASTENERS	3.19
ILLUSTRATION 3.I.4: TONG ASSEMBLY - SUPPORT ROLLER INSTALLATION 01.....	3.20
ILLUSTRATION 3.I.5: TONG ASSEMBLY - SUPPORT ROLLER INSTALLATION 02.....	3.21
ILLUSTRATION 3.I.6: TONG ASSEMBLY - SUPPORT ROLLER INSTALLATION 03.....	3.22
ILLUSTRATION 3.I.7: TONG ASSEMBLY - TOP SHIFTER BUSHING INSTALLATION.....	3.23
ILLUSTRATION 3.I.8: TONG ASSEMBLY - FRONT LEG MOUNT WELDMENT INSTALLATION.....	3.25
ILLUSTRATION 3.I.9: TONG ASSEMBLY - SAFETY DOOR VALVE INSTALLATION.....	3.26
ILLUSTRATION 3.I.10: TONG ASSEMBLY - LEVELING BOLT INSTALLATION	3.27
ILLUSTRATION 3.I.11: TONG ASSEMBLY - VALVE HANDLE GUARD INSTALLATION (CE MARKED TONGS).....	3.28
ILLUSTRATION 3.M.1: SHIPPING INSTRUCTIONS - PALLET.....	3.38
ILLUSTRATION 3.M.2: SHIPPING INSTRUCTIONS - WRAPPING CHAIN SLING	3.39
ILLUSTRATION 3.M.3: SHIPPING INSTRUCTIONS - BACKUP SUPPORT	3.39
ILLUSTRATION 3.M.4: SHIPPING INSTRUCTIONS - STRAPPING EQUIPMENT TO PALLET.....	3.40
ILLUSTRATION 4.B.1: RELIEF VALVE TROUBLESHOOTING - TEMPORARY GAUGE INSTALLATION	4.2
ILLUSTRATION 6.A.1: TORQUE GAUGE (FOR ILLUSTRATION PURPOSES ONLY)	6.1
ILLUSTRATION 6.A.2: TENSION LOAD CELL	6.1
ILLUSTRATION 6.A.3: COMPRESSION LOAD CELL.....	6.1
ILLUSTRATION 6.A.4: COMPRESSION LOAD CELL EXPLODED	6.3
ILLUSTRATION 6.A.5: TURN COUNTER ENCODER MOUNT EXPLODED.....	6.4

The information presented in this document will provide setup, operating, and maintenance instructions for your KT13625 or LW13625 tong and backup assembly. Due to the wide variety of operating conditions, these instructions must be considered guidelines rather than absolute operating procedures. It is the responsibility of the user to use these guidelines together with an experienced manager to develop operating procedures that conform to all policies set forth by the operating authority (ies).

IDENTIFICATION OF OF WARNINGS AND OTHER NOMENCLATURE OF IMPORTANCE USED IN THIS INSTALLATION GUIDE

McCoy Drilling & Completions uses three indicators to describe items of three degrees of importance.

A **HAZARD** to operators or equipment is represented by an exclamation point within a red triangle. identifies items of the highest importance. Failure to heed information identified by a **HAZARD** symbol may result in bodily injury, death, catastrophic equipment damage, or any combination of these. A **HAZARD** may also indicate the potential for dangerous environmental contamination.



This identifies a **HAZARD** to operators or equipment

A **WARNING** is represented by an exclamation point within an orange triangle, and contains information that will alert personnel to a potential safety hazard that is not life-threatening. A **WARNING** may also serve to alert the user to information critical to the correct assembly or operation of the equipment in use.



This identifies a **WARNING** to users

A **CAUTION** is represented by an exclamation point within a yellow triangle and highlights information that may aid the user during assembly or operation of your equipment. **CAUTION**s are also used to ensure common errors are not made during assembly or operation of your equipment.



This identifies a **CAUTION** to users

Some sections of this technical manual apply only to “**CE Marked**” equipment. These sections will be clearly identified by the use of the phrase “applies to CE-marked tongs only”, or by use of the CE logo within an enclosed border.



This identifies a section that only applies to CE-Marked equipment

Observance of the following is the full responsibility of the user:

- all descriptions, information and instructions set out in this manual
- any regulation or requirement issued by an authority or agency which may influence operation, safety or integrity of the equipment that overrules the content of this document.
- any legal or other mandatory regulation in force governing accident prevention or environmental protection.

Congratulations on the purchase of your KT-13625 / LW-13625 13-5/8" tong and FARR® backup. This unit will provide you with years of outstanding performance. Simple maintenance and care will extend its life and ensure years of excellent performance and reliability. The setup, operating, and maintenance instructions in this manual will assist you in giving your equipment the care it requires. Please carefully read the manual before installing and using your equipment. Replacement parts are readily available from McCoy Drilling & Completions | FARR in Edmonton Alberta. Note that many parts are transferable between FARR® tongs and backups. Should you need replacement parts, or should you experience any difficulty not covered in this manual, please contact:

McCoy Drilling & Completions | FARR

14755 121A Avenue
Edmonton, Alberta
Canada T5L 2T2
Phone: 780.453.3277
Fax: 780.455.2432

Sales Fax: 780.481.9246

Email Engineering: engFarr@mccoyglobal.com

Email Sales: salesFarr@mccoyglobal.com

Customer Care: customerCareFarr@mccoyglobal.com

Website: <http://www.mccoyglobal.com/drilling-completions>



ILLUSTRATION 1.A.1: KT13625 TONG & FARR® BACKUP (MODEL 80-0935-4 SHOWN)

Color Coding:

Green = Handle or control, safe to grasp or manipulate

Yellow = Active or potential hazard. Use caution not to contact area especially when tong is rotating.

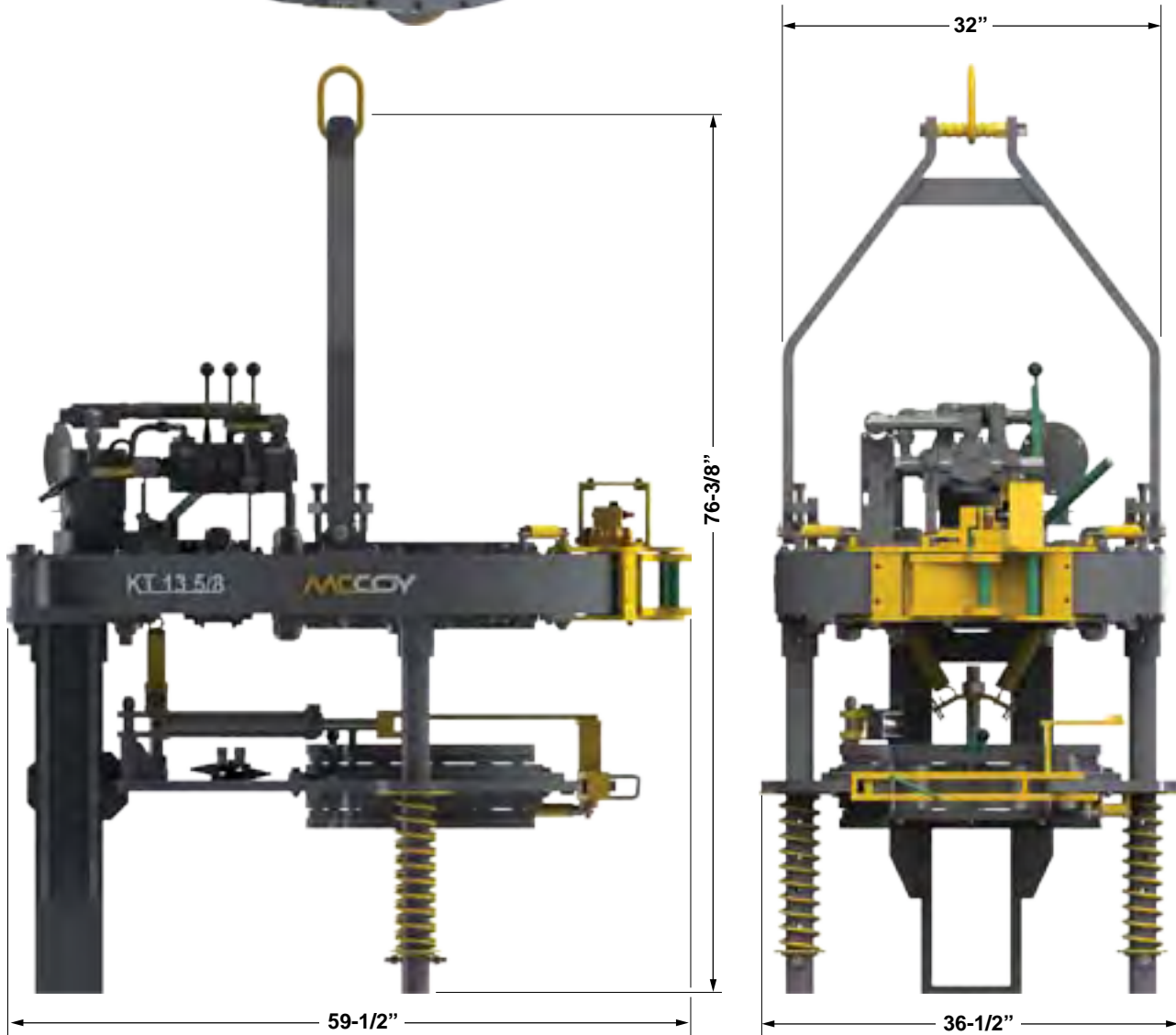
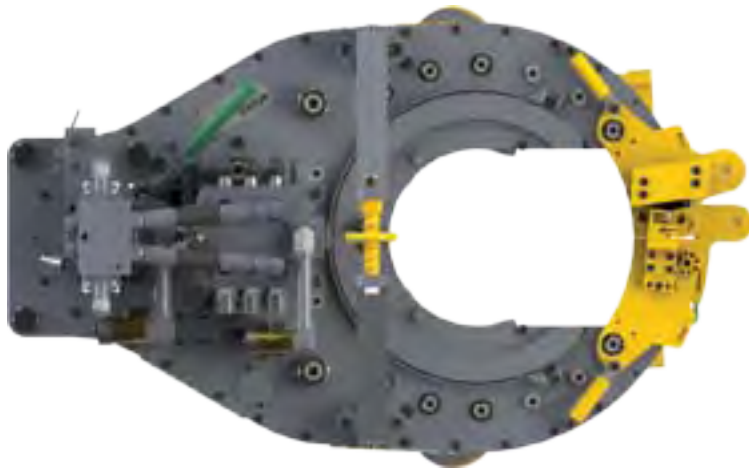
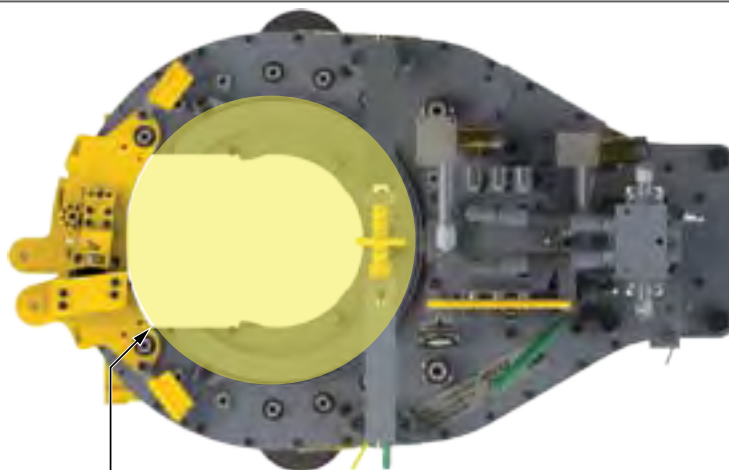

ILLUSTRATION 1.A.2: KT13625 TONG & FARR® BACKUP DIMENSIONS



THIS PAGE ILLUSTRATES THE "SAFE TO HANDLE" AND "HAZARD" AREAS OF THIS EQUIPMENT

In addition to the **HAZARD** areas of this equipment that are coated **YELLOW**, a rotating cage plate assembly and backup clamp cylinders pose significant hazards when the equipment is active. Keep hands clear of the cage plate and backup clamp cylinders when equipment is energized. **SAFE** areas to handle while the equipment is energized are indicated by **GREEN** coating



Keep hands clear of cage plate when equipment is energized

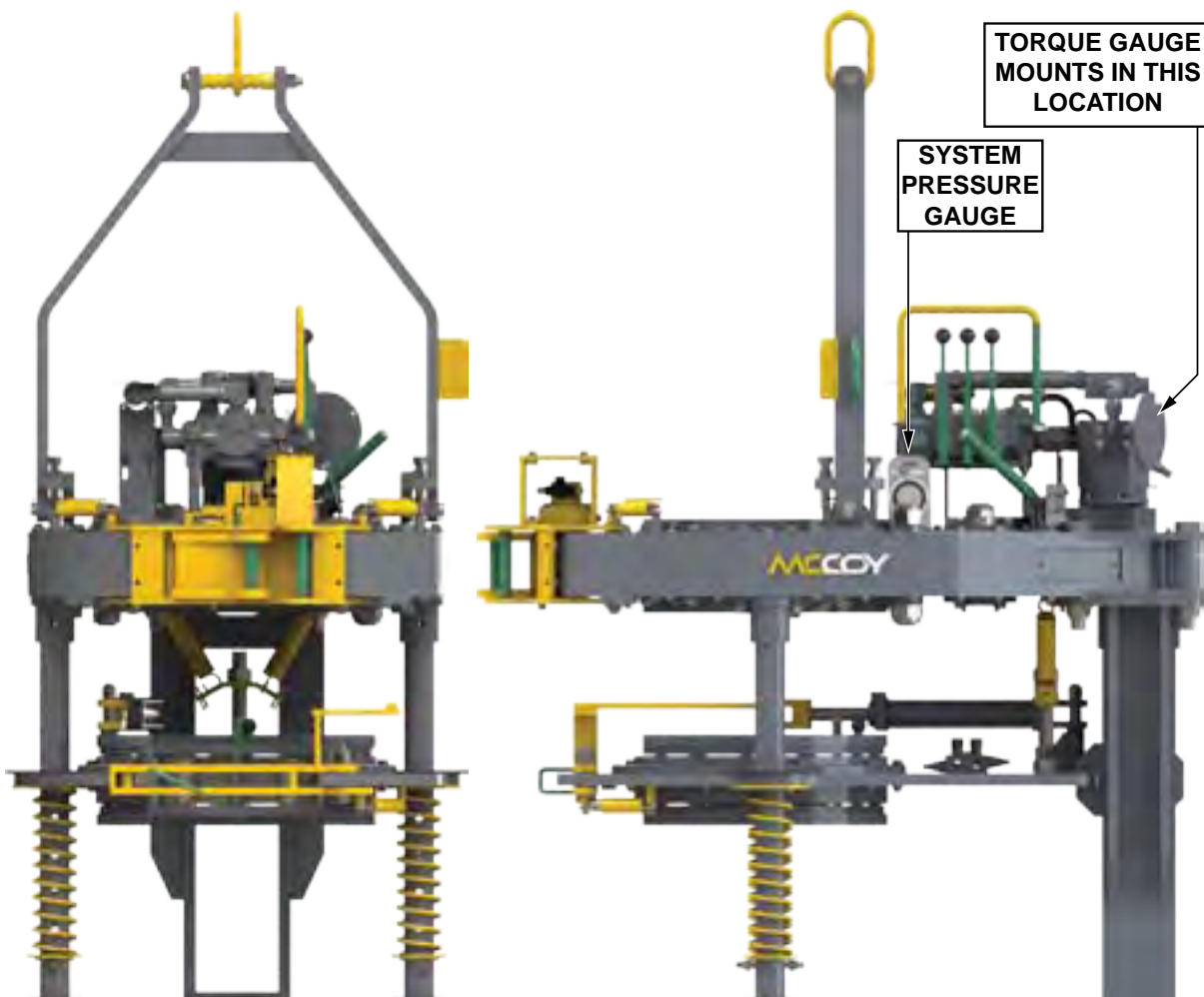

ILLUSTRATION 1.A.3: KT13625 TONG & FARR® BACKUP HAZARD AREAS (CE-MARKED MODEL SHOWN)

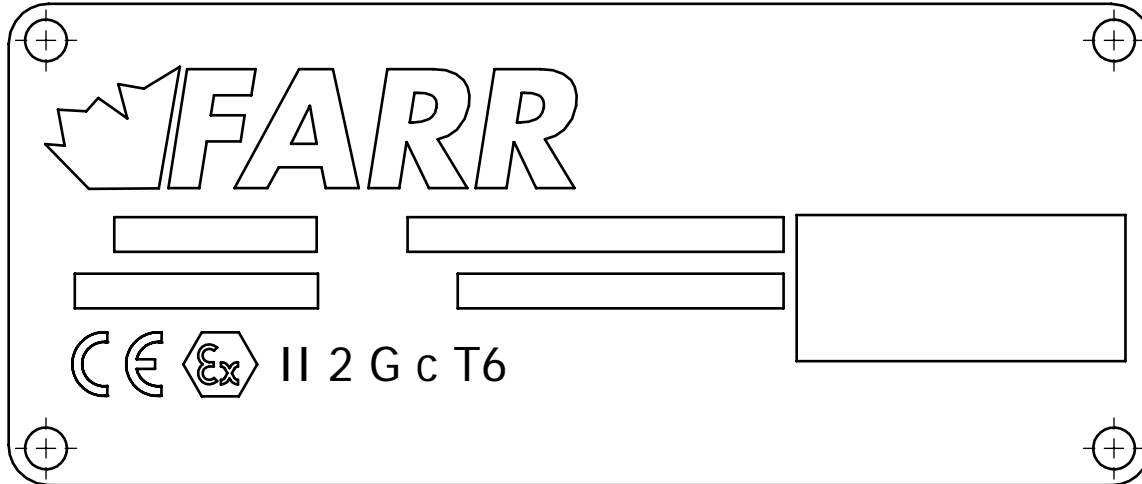

ILLUSTRATION 1.A.4: FARR® CE NAMEPLATE

CE CE compliant. Conforms with the essential requirements of the applicable Conformité Européenne directives.

Ex EU Explosive Atmosphere certified

II Equipment Group (surface, non-mining)

2 Equipment Category - high level of protection

Gc Gas Group (Acetylene & Hydrogen) - Certified for use in an acetylene / hydrogen environment

T6 Maximum surface temperature of 85 °C.

Specifications - KT13625

Torque Table (Standard Tong) **

Pressure	High Gear		Low Gear		
	PSI / MPa	Lbs.-ft.	Nm	Lbs.-ft.	Nm
1500 / 10.34		3530	4786	17640	23917
2000 / 13.79		4970	6738	24840	33679
2500 / 17.24		6410	8691	32040	43440
2750 / 18.96		7130	9667	35640	48321

MAXIMUM RATED TORQUE: 35000 LBS.-FT. / 47450 Nm

Speed Table

Flow (US GPM / LPM)	Low Gear (RPM)	High Gear (RPM)
10 / 37.9	1.6	8
20 / 75.71	3.2	16
40 / 151.4	6.4	32
60 / 227.1	9.6	48

Specifications - LW13625

Torque Table (Lightweight Tong) **				
Pressure	High Gear		Low Gear	
	PSI / MPa	Lbs.-ft.	Nm	Lbs.-ft.
1000 / 6.895	1696	2299	8482	11500
1500 / 10.34	2866	3886	14332	19432
2000 / 13.79	4036	5472	20181	27362
2400 / 16.55	4972	6741	24861	33707
MAXIMUM RATED TORQUE: 25000 LBS.-FT. / 33895 Nm				

Speed Table		
Flow (US GPM / LPM)	Low Gear (RPM)	High Gear (RPM)
10 / 37.9	1.8	9.2
20 / 75.71	3.7	18.5
40 / 151.4	7.4	36.9
60 / 227.1	11.1	55.4

**** These are ideal values. Actual achieved torque is highly dependant upon tong efficiency, final position of rotary gear when full torque load is reached, and the motor with which the tong is equipped.**

Maximum Hydraulic Requirements (KT13625)	60 GPM (227.1 LPM)
	3000 PSI (20.684 MPa)
Maximum Hydraulic Requirements (LW13625)	60 GPM (227.1 LPM)
	2500 PSI (17.237 MPa)
Maximum Dimensions	
Length (Doors Closed)	59-3/8" / 150.8 cm
Height	47" / 119.4 cm
Width	33-3/4" / 85.7 cm
Maximum Elevator Diameter	Unlimited (tong comes off pipe)
Torque Arm Length (Pipe center to anchor center)	32" / 81.3 cm
Dead Weight (Equipment Only, Approximate)	2370 lbs / 1077 kg
Maximum Rigid Sling Load	3685 lbs / 1675 kg
Sound Level (dBa)	87 dB A @ 1m / 88 dB C @ 1m
Jaws available (inches)	All standard sizes from 3-1/2" to 13-5/8" (See Pg. 2.14)
Recommended Spring Hanger	85-0106X (Capacity = 1800 lbs / 818 kg)



ONLY USE SPRING HANGER SUPPLIED BY MCCOY. IF USING SPRING HANGER REFER TO SECTION 2.H FOR PROPER RIGGING INSTRUCTIONS.



ALL REPLACEMENT FASTENER (BOLTS, NUTS, CAP SCREWS, MACHINE SCREWS, ETC.) USED DURING MAINTENANCE OR OVERHAUL MUST BE GRADE 8 OR EQUIVALENT UNLESS OTHERWISE SPECIFIED.

Use an EP synthetic grease that meets or exceeds the following specifications:

Thickener	Lithium Complex
NLGI consistency grade	2
NLGI performance grade	GC-LB
Penetration - ASTM D 217 (25°C [77°F])	265-295 minimum 0.1 mm) worked 60 strokes
Dropping point, °F[°C] - ASTM D2265	550 [288] minimum
High temperature life, hours - ASTM D 3527	160 minimum
Oxidation stability, psi - ASTM D 942	(100 hr/300 hr) 0/3
Water washout, percent - ASTM D 1264	1.8 max
Rust and corrosion - ASTM D 1743	pass
Oil separation, percent loss - ASTM D 1742	1.1 max (24 hours, 25°C [77°F])
Leakage, g lost - ASTM D 4290	1.0 max
Four ball wear test, mm scar - ASTM D 2266	0.40 max
Fretting wear, mg - ASTM D 4170	3.4 max
Four ball EP, kgf - ASTM D 2596:	
Weld point:	400 minimum
Load wear index:	50 minimum
Timken OK load test, lbs - ASTM D 2509	50
Low temperature torque, N*m - ASTM D 4693	1.3 max (-40°C [-40°F])
LT-37 pumpability, g/min	360/7 (60°F/0°F [16°C/-18°C])
Copper corrosion - ASTM D 4048	1B
Oil viscosity: 40°C [104°F], cSt	151
100°C [212°F], cSt	19.2
Flash point, °F[°C] - ASTM 92	450[232]

Use a premium quality hydraulic fluid that meets or exceeds the following specifications:

Typical Density (kg/m ³)	878
Viscosity - cSt @ 40 °C	68.8
- cSt @ 100 °C	8.7
Viscosity Index	97
Pour Point °F [°C]	-22 [-30]
Flash Point °F [°C]	432 [222]
Colour, ASTM	1.5
Neutralization Number	0.40
Rust Protection - Distilled Water	No Rust
- Sea Water	No Rust
Hydrolytic Stability - Cu Mass Loss, mg/cm ²	0.04
Copper Corrosion Test	1A
Filterability: Denison - Wet & Dry	Pass
Afnor - Wet & Dry	Pass
Cincinatti Milacron Spec Approved	P69
Denison HF-0:	Approved
Denison P-46 Piston Pump:	Pass
Denison T6C Vane Pump:	Pass
Vickers 35VQ25 Vane Pump Test:	Pass
Vane pump test total ring and vane wear, mg.	<10
Oxidation Stability:	
Turbine Oil Stability Test Life, hours	2500+
Rotary Bomb Oxidation Test, minutes	325
FZG Spur Gear Test, Failure Load Stage (FLS)	12

Adequate setup and proper hydraulic connections are essential in ensuring reliable operation of your tong. For best results and long term reliability, read and obey the start-up instructions in this section.

A. INITIAL RECEIPT AND INSPECTION OF EQUIPMENT



YOUR EQUIPMENT HAS BEEN THOROUGHLY TESTED AND INSPECTED AT THE FACTORY. HOWEVER, MCCOY ADVISES INSPECTING YOUR EQUIPMENT FOR SHIPPING DAMAGE UPON RECEIPT AND TESTING YOUR TONG BEFORE RELEASING TO AN OPERATIONAL ENVIRONMENT.

Perform a visual inspection following removal of all packaging material. Immediately identify any shipping damage to the shipping company, and correct all damage before connecting equipment to a hydraulic power source.

B. MAJOR COMPONENT IDENTIFICATION

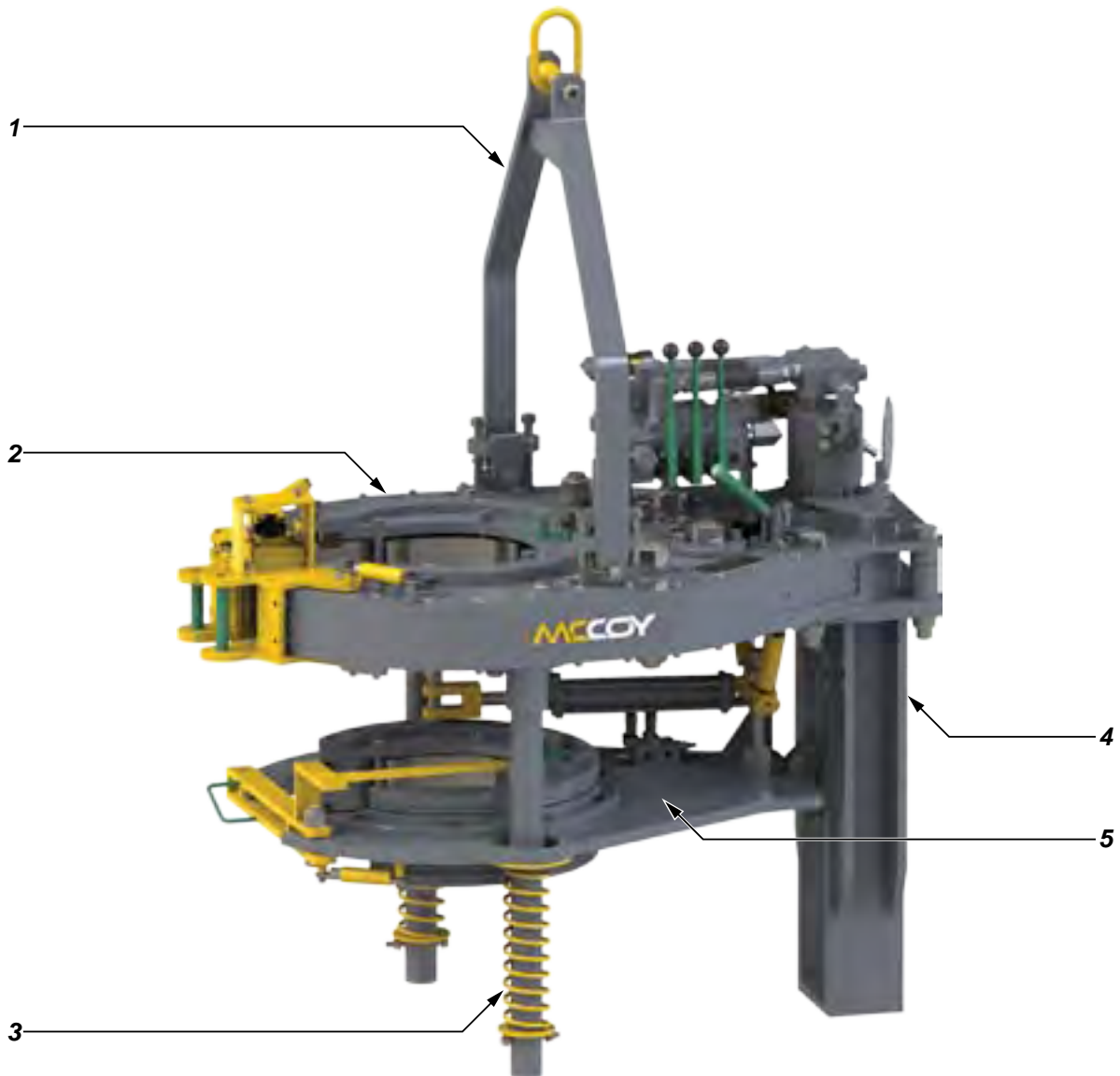

ILLUSTRATION 2.B.1: KT13625 TONG & FARR® BACKUP MAJOR COMPONENT IDENTIFICATION 01

Item	Description
1	Rigid Sling
2	Tong
3	Front Leg Assembly
4	Rear Leg Weldment
5	FARR® Backup

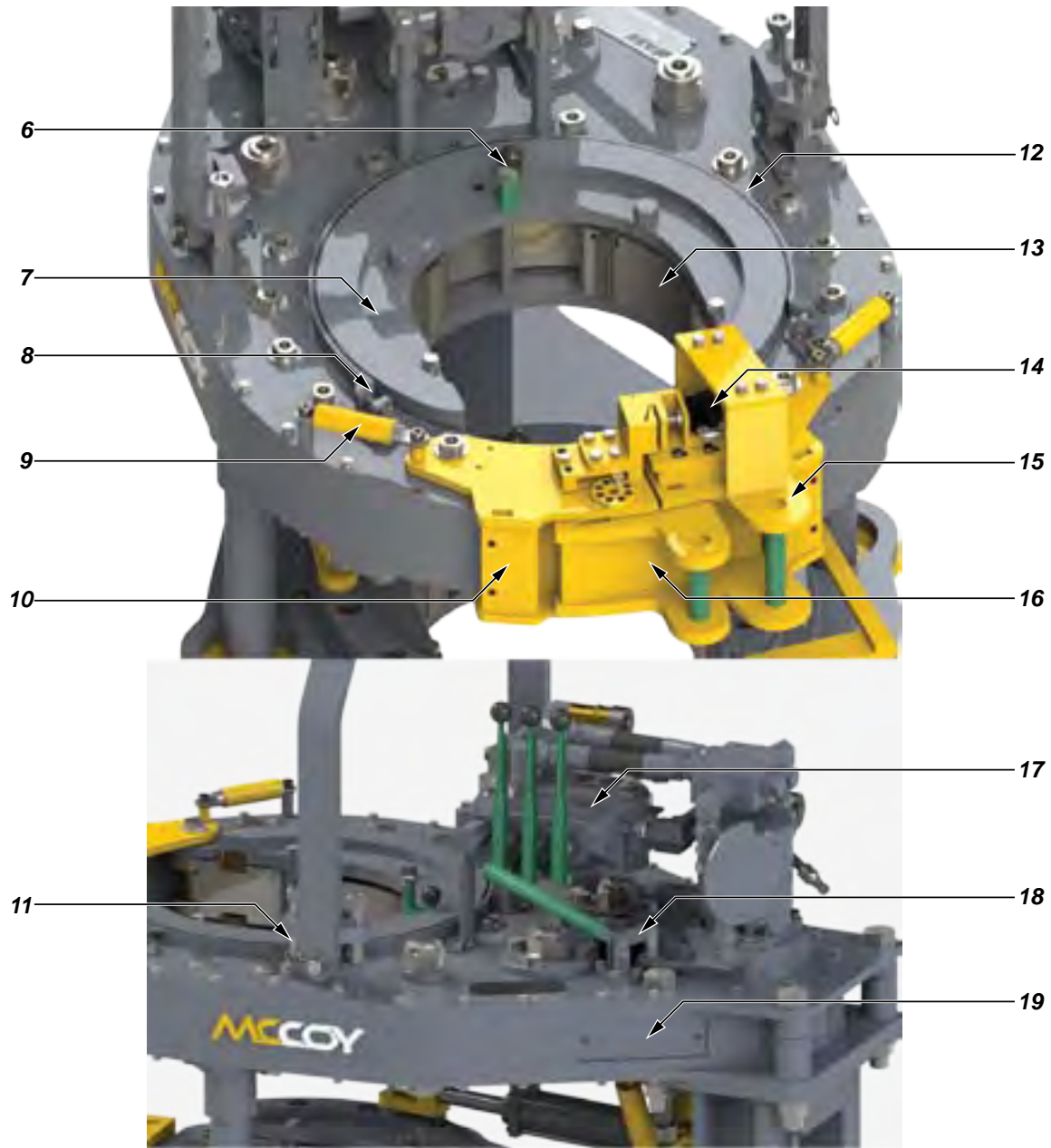

ILLUSTRATION 2.B.2: KT13625 TONG & FARR® BACKUP MAJOR COMPONENT IDENTIFICATION 02

Item	Description
6	Backing Pin Assembly
7	Cage Plate Assembly
8	Brake Band Adjustment
9	Tong Door Spring Stop Cylinder
10	RH Door Assembly
11	Tong Leveling Adjustment
12	Brake Band
13	Tong Jaws with Die Inserts
14	Safety Door Assembly
15	LH Door Assembly

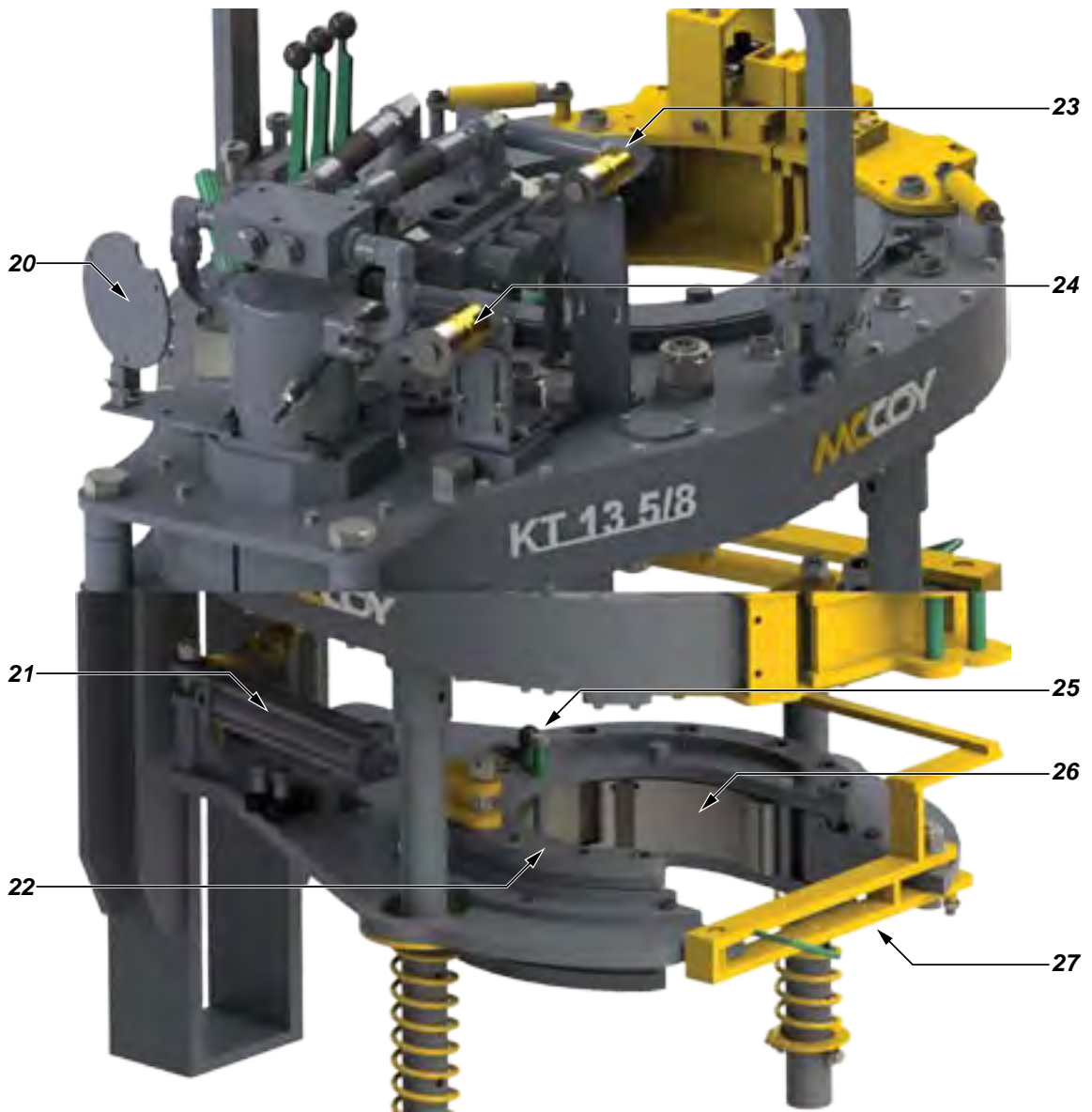

ILLUSTRATION 2.B.3: KT13625 TONG & FARR® BACKUP MAJOR COMPONENT IDENTIFICATION 03

Item	Description
16	Tong Door Latch
17	Hydraulic Valve Assembly
18	Manual Shift Assembly
19	Inspection Panel
20	Torque Gauge Mounting Plate
21	Backup Clamp Cylinder
22	Backup Cam Ring Assembly
23	Hydraulic Fluid Inlet Quick-Connect Coupling
24	Hydraulic Fluid Outlet Quick-Connect Coupling
25	Backup Backing Pin Assembly
26	Backup Jaws c/w Dies
27	Backup Door

C. SLING / LOAD BEARING DEVICE SAFETY



THE SUPPLIED LOAD-BEARING DEVICE (CHAIN SLING, RIGID SLING, SPREADER BAR ASSEMBLY, FRAME, OR ANY OTHER DEVICE THAT BEARS THE PARTIAL OR TOTAL WEIGHT OF THE EQUIPMENT DESCRIBED IN THIS MANUAL) HAS BEEN SPECIFIED OR DESIGNED TO SUPPORT THE EQUIPMENT DESCRIBED IN THIS DOCUMENT. FARR WILL NOT GUARANTEE THE ABILITY OF THE LOAD-BEARING DEVICE TO SUPPORT ANY OTHER PART, ASSEMBLY OR COMBINATION OF PARTS AND ASSEMBLIES, OR ANY ADDITIONS TO THE EQUIPMENT DESCRIBED IN THIS MANUAL THAT ADD WEIGHT TO THE EQUIPMENT, UNLESS SUPPLIED BY MCCOY DRILLING & COMPLETIONS.

MCCOY DRILLING & COMPLETIONS DOES NOT GUARANTEE THE INTEGRITY OF MODIFIED OR DAMAGED LOAD-BEARING DEVICES, UNLESS THOSE MODIFICATIONS ARE PERFORMED BY MCCOY DRILLING & COMPLETIONS.

McCoy Drilling & Completions recommends following an industry-accepted standard such as OSHA, ASME B30.9-2006, or manufacturer's guidelines when performing any rigging and overhead lifting. Use by untrained persons is hazardous. Improper use will result in serious injury or death. Do not exceed rated capacity. Slings will fail if damaged, abused, misused, overused, or improperly maintained.

- Only grade 80 or grade 100 alloy chain should be used for overhead lifting applications.
- Working Load Limit (WLL) is the maximum allowable load in pounds which may be applied to the load-bearing device, when the device is new or in "as new" condition, and when the load is uniformly and directly applied. The WLL must never be exceeded.
- Working Load Limit (WLL) is the maximum working load for a specific minimum sling angle, measured from the horizontal plane. The Working Load Limit is identified on the sling.
- The Working Load Limit or Design factor may be affected by wear, misuse, overloading, corrosion, deformation, intentional alterations, sharp corner cutting action and other use conditions.
- Shock loading and extraordinary conditions must be taken into account when selecting alloy chain slings.
- See OSHA Regulation for Slings 1910.184, ANSI/ASME B30.9-"SLINGS", ANSI/ASME B30.10-"HOOKS" and ANSI/AMSE B30.26 "RIGGING HARDWARE" for additional information.



THE MINIMUM SLING ANGLE (THE ANGLE OF THE LEG OF THE SLING MEASURED FROM THE HORIZONTAL) MUST NEVER FALL LOWER THAN THE ANGLE SPECIFIED FOR THE SLING IN USE

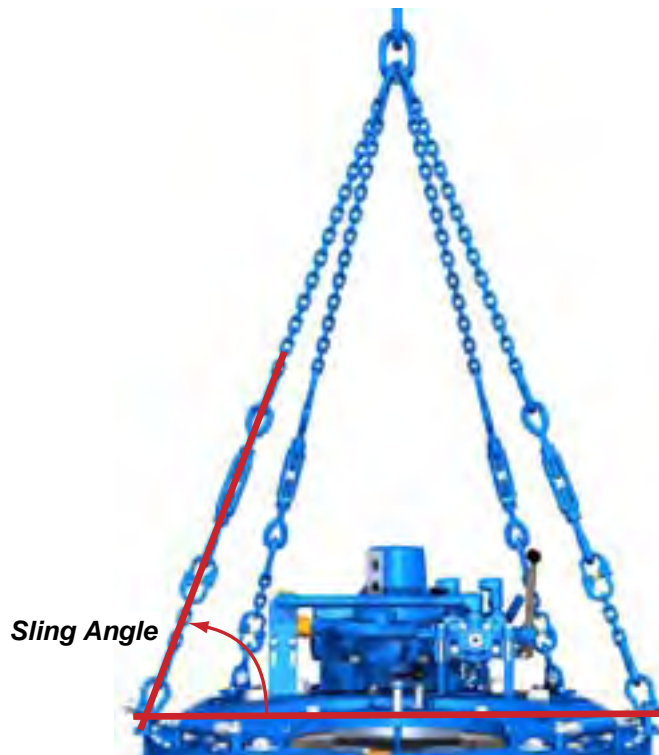

ILLUSTRATION 2.C.1: SLING ANGLE

1. Inspection Of Slings

McCoy strongly recommends the following practices:

A complete inspection of new load-bearing devices and attachments shall be performed by a qualified, designated person prior to initial use. Each link and component shall be examined individually, taking care to expose and examine all surfaces including the inner link surface. The sling shall be examined for conditions such as those listed in the removal criteria below. In addition, daily inspection of slings, fastenings and attachments shall be performed by a designated person. If damage or defects are found at either inspection, the damaged or defective component shall be quarantined from service until it can be properly repaired or replaced.

Removal Criteria:

A load-bearing device shall be removed from service if conditions such as the following are present:

- Missing or illegible sling identification.
- Cracks or breaks
- Evidence of tampering is seen - sling tag has been modified or obscured, or tamper-proof nuts are missing.
- Signs of impact on load-bearing components, including spreader bars, lifting lugs, rigid slings & rigid sling weldments, and legs & leg mounts.
- Broken or damaged welds.
- Excessive wear, nicks, or gouges. Refer to the chart below to ensure minimum thickness on chain links supplied is not be below the values listed:

Minimum Allowable Chain Link Thickness at Any Point			
Nominal Chain Size		Minimum Thickness	
Inches	MM	Inches	MM
7/32	5.5	0.189	4.80
9/32	7	0.239	6.07
5/16	8	0.273	6.93
3/8	10	0.342	8.69
1/2	13	0.443	11.26
5/8	16	0.546	13.87
3/4	20	0.687	17.45
7/8	22	0.750	19.05
1	26	0.887	22.53
1-1/4	32	1.091	27.71
Refer To ASME B30.9			

- Stretched, bent, twisted, or deformed chain links or components.
- Evidence of heat damage.
- Excessive pitting or corrosion.
- Lack of ability of chain or components to hinge (articulate) freely.
- Weld splatter.
- For hooks, removal criteria as stated in ASME B30.10
- Other conditions, including visible damage, that cause doubt as to the continued use of the sling.

Inspect all lugs and fixing points for signs of elongation and/or bending, or for material build-up around the hole. Repair or replace components that appear distorted. Ensure all hardware is tight and in good condition. Replace missing hardware if necessary. All hardware must be free of rust and corrosion.

Additional inspections shall be performed during sling use where service conditions warrant. Periodic inspection intervals shall not exceed one year. The frequency of periodic inspections should be based on:

- Frequency of use of the load-bearing device.
- Severity of service conditions
- Nature of lifts being made
- Experience gained on the service life of load-bearing devices used in similar circumstances.

Guidelines for the interval are:

- Normal Service - yearly
- Severe Service - monthly to quarterly
- Special Service - as recommended by a qualified person

Units designed and manufactured in accordance with EN 12079 and DNV 2.7-1 should be tested and examined in accordance with the following schedule of examination and test. The user of the load-bearing device shall place a permanent placard or plate upon which the type and date of the last test shall be recorded. To avoid confusion, the plate shall not carry the date of the next test or examination, only the most recent.

Test / Examination				
TIME / INTERVAL	LIFTING TESTS ¹	NON-DESTRUCTIVE EXAMINATION (NDE) OF LIFTING POINTS	THOROUGH VISUAL EXAMINATION	SUFFIX TO BE MARKED ON PLATE ATTACHED TO UNIT
Initial Certification By Farr / Superior	YES	YES	YES	T
Interval Not Exceeding 12 Months	At the discretion of inspection body	At the discretion of inspection body	YES	T or VN ³
Interval Not Exceeding 60 Months	At the discretion of inspection body	YES	YES	T or VN
Following Substantial Repair or Alteration	YES	YES	YES	T

1. Lifting test as per S 7.3 BS EN 12079 or DNV 2.7-1 May 1995
 2. T = Proof Test, non-destructive examination; VN = non destructive examination and visual examination; V = visual examination.
 3. Dependant upon whether non-destructive examination has been carried out.
 4. For the purposes of this standard, a substantial repair or modification is defined as any repair and/or modification that has been carried out which may, in the opinion of the inspection body, affect the load-bearing elements of the container or lifting device, or elements that contribute directly to its structural integrity.



IF MECHANICAL DAMAGE IS SEEN OR SUSPECTED ON A LOAD-BEARING DEVICE, OR IF THE LOAD-BEARING DEVICE HAS BEEN OVERLOADED, IT MUST BE REMOVED FROM SERVICE AND QUARANTINED UNTIL RECERTIFIED

Written records of the most recent periodic inspection shall be maintained, and shall include the condition of the sling.

2. Proper Use Of Load-Bearing Devices

Whenever any load-bearing device is used, the following practices shall be observed.

- Load-bearing devices that are damaged or defective shall not be used.
- Slings shall not be shortened with knots or bolts or other makeshift devices.
- Sling legs shall not be kinked.
- Load-bearing devices shall not be loaded in excess of their rated capacities.
- Slings shall be securely attached to their load.
- Load-bearing devices shall be protected from snagging, and shall not be further obstructed by any object.
- Suspended loads shall be kept clear of all obstruction.
- All employees shall be kept clear of loads about to be lifted and of suspended loads.
- Hands or fingers shall not be placed between the sling and its load while the sling is being tightened around the load.
- Shock loading is prohibited.
- Do not stand directly under a load during lifting.

3. Storage Of Load-Bearing Devices

Proper storage of out-of-service load bearing devices is important to ensure full integrity of the device once it is returned to service. McCoy recommends observing the following practices.

- Wipe off all excess grease. Use a solvent-based cleaner on rags to wipe all external surfaces to remove residual grease or hydraulic fluid. Once the outside surfaces have been de-greased, wipe all external surfaces with clean water to remove residual solvent.
- McCoy recommends that an anti-corrosive agent such as Tectyl® 506 be applied to all external surfaces. Refer to manufacturer data sheets for proper application and safety information. Allow the anti-corrosive coating ample time to dry - refer to manufacturer data sheets for drying times at room temperature.
- Store in a clean, dry location. When returning to service, note that a full inspection of the device must be performed.

D. LIFT CYLINDER INSTALLATION

The lift cylinder is not orientation-specific; that is, the lift cylinder will function the same way independent of which end is connected to the crane and which end is connected to the main lifting lug of the tong (or the spring hanger, if used). However, McCoy recommends orienting the lift cylinder with the hydraulic hose connection at the bottom of the cylinder to ensure the hose is not stressed when cylinder is at full extension.



TEST LIFT CYLINDER BEFORE INSTALLATION. REFER TO THE LIFT CYLINDER TECHNICAL MANUAL FOR DETAILED TESTING AND OPERATING PROCEDURES, AND DETAILED SAFETY GUIDELINES.



IF USING A SPRING HANGER ITS WEIGHT MUST BE ACCOUNTED FOR WHEN CALCULATING TOTAL SUSPENDED WEIGHT.

1. Installation Procedure

- i. Use a crane to hoist the lift cylinder by the shackle, ensuring the hydraulic hose connection is at the bottom of the cylinder when it is hoisted.
- ii. Remove the two R-clips securing the clevis pin, and remove the clevis pin.
- iii. Orient the spring hanger so the piston will extend down during thread make-up, preventing water and debris from gathering around the seal.
- iv. Place the welded U-connection inside the clevis. Replace the clevis pin, and secure the clevis pin with the two R-clips.
- v. Hoist the lift cylinder and spring hanger.
- vi. Place a 1" shackle around the master lifting link on the tong sling. Secure the shackle to the extending end of the spring hanger using the 1-1/8" UNC x 4-3/4" modified hex bolt and 1-1/8" UNC hex jam nut. Secure the jam nut to the bolt using a 3/16" x 1-1/4" cotter pin.

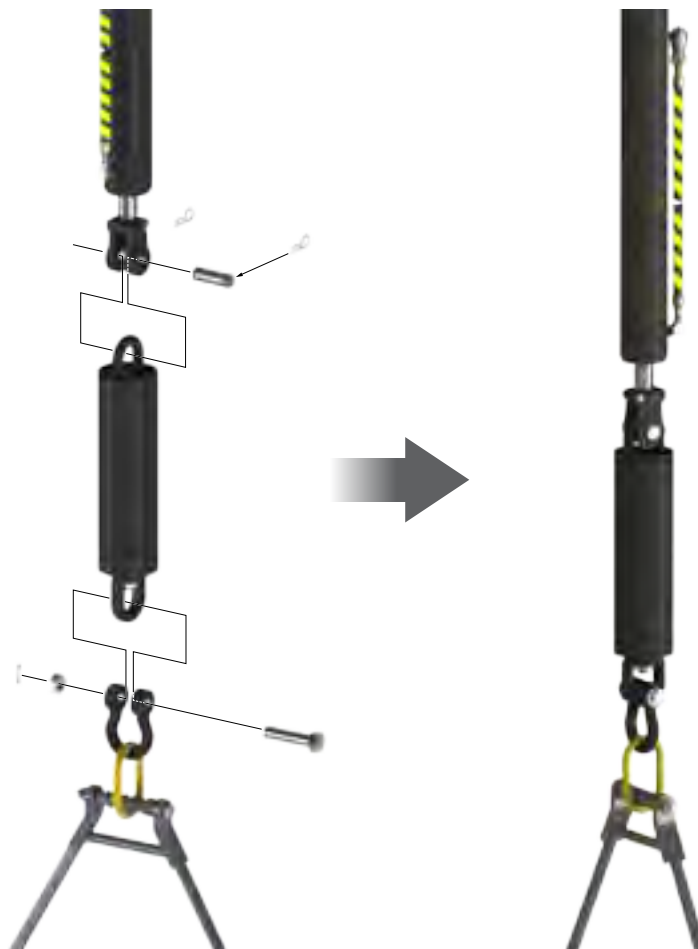

ILLUSTRATION 2.D.1: LIFT CYLINDER & SPRING HANGER INSTALLATION

2. Lift Cylinder Connection

Inspect the hydraulic hose before connection, ensuring the line is free of ruptures, cracks, cuts, or other damage. Inspect the female quick-connect fitting to ensure it is free from damage. Connect the female quick-connect on the lift cylinder hydraulic hose to the male quick-connect fitting attached to the needle valve on the tong valve bank. Once the fitting has snapped into place give the hydraulic line a light tug upwards to ensure the fitting is securely seated.

If not already done, connect the main hydraulic supply to the power tong (see section 2.F for proper hydraulic connection procedure). Energize the hydraulic supply to the power tong.

Lift the power tong approximately three inches off the work surface, and suspend the tong for approximately thirty seconds. Following the suspension alternately lift and lower the tong slightly to confirm that lift and lower functions each operate correctly.

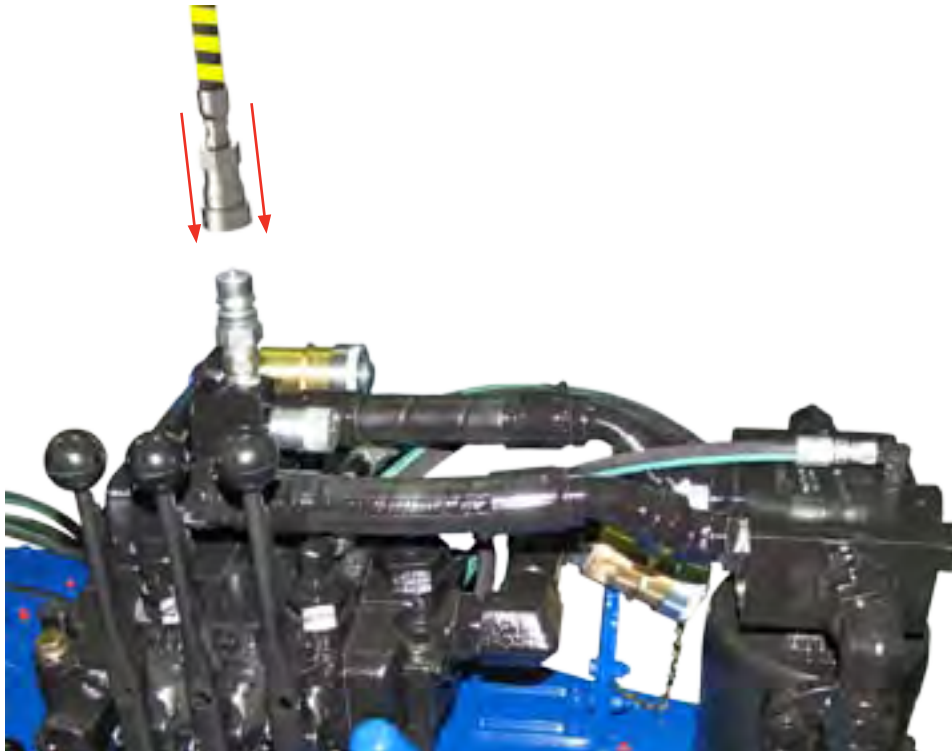

ILLUSTRATION 2.D.2: LIFT CYLINDER HYDRAULIC CONNECTION

3. Lift Cylinder Safety



A CLEARLY IDENTIFIED REMOTE POWER PACK EMERGENCY STOP MUST BE INSTALLED IN THE IMMEDIATE VICINITY OF THE TONG OPERATOR.

McCoy Drilling & Completions recommends following an industry-accepted standard such as OSHA, ASME B30.9-2006, or manufacturer's guidelines when performing any rigging and overhead lifting. Use by untrained persons is hazardous. Improper use will result in serious injury or death. Do not exceed rated capacity.

Working Load Limit (WLL) is the maximum allowable load in pounds which may be applied to the load-bearing device, when the device is new or in "as new" condition, and when the load is uniformly and directly applied. The WLL must never be exceeded.

The Working Load Limit or Design factor may be affected by wear, misuse, overloading, corrosion, deformation, intentional alterations, sharp corner cutting action and other use conditions.

See OSHA Regulation for Slings 1910.184, ANSI/ASME B30.9-"SLINGS", ANSI/ASME B30.10-"HOOKS" and ANSI/AMSE B30.26 "RIGGING HARDWARE" for additional information.

Lift Cylinder Safety (continued):

The flexible line providing hydraulic power to the lift cylinder has been equipped with abrasion-resistant, high visibility protective wrap. The high visibility wrap allows operators to easily see monitor the position of the hydraulic line at all times, and can easily see if the line appears to become entangled or snagged.



IMMEDIATELY CEASE LIFT CYLINDER OPERATION IN THE EVENT OF ENTANGLEMENT OF THE HYDRAULIC LINE WITH FIXED RIG COMPONENTS OR TONG SUPERSTRUCTURE.

The protective wrap also prevents wear of the hydraulic line through abrasion. Do not remove the protective wrap from the lift cylinder line, and replace protective wrap if it is missing, torn, or split. Regardless of use or condition, the hydraulic line supplying the lift cylinder must be replaced every two years.



REPLACE LIFT CYLINDER HYDRAULIC LINE EVERY TWO YEARS

The control valve section on the power tong is equipped with an internal check valve, preventing sudden drop of the tong in the event of hydraulic power failure. A speed-limiting orifice is installed in the breather port of the lift cylinder. The orifice prevents sudden drop of the lift cylinder in the event of a ruptured hydraulic line, limiting the speed at which the cylinder extends and the tong drops to a safe rate. Do not remove the speed-limiting orifice, and only replace with an identical orifice supplied by McCoy.



DO NOT REMOVE THE SPEED-LIMITING ORIFICE FROM THE LIFT CYLINDER BREATHER PORT

The working load limit (WLL) is clearly stenciled on to the side of the lift cylinder. Do not use lift cylinder if the WLL stencil has been rubbed off or intentionally removed. Locate the test certificate that accompanied the cylinder to the job site or, if necessary, obtain a copy of the test certificate from the location at which the original certificate has been stored. The lift cylinder must be clearly re-marked with the WLL before it is released to an operating environment.



DO NOT USE A LIFT CYLINDER WITH A MISSING OR DEFACED WLL STENCIL.

E. HYDRAULICS

1. Hydraulic Schematics

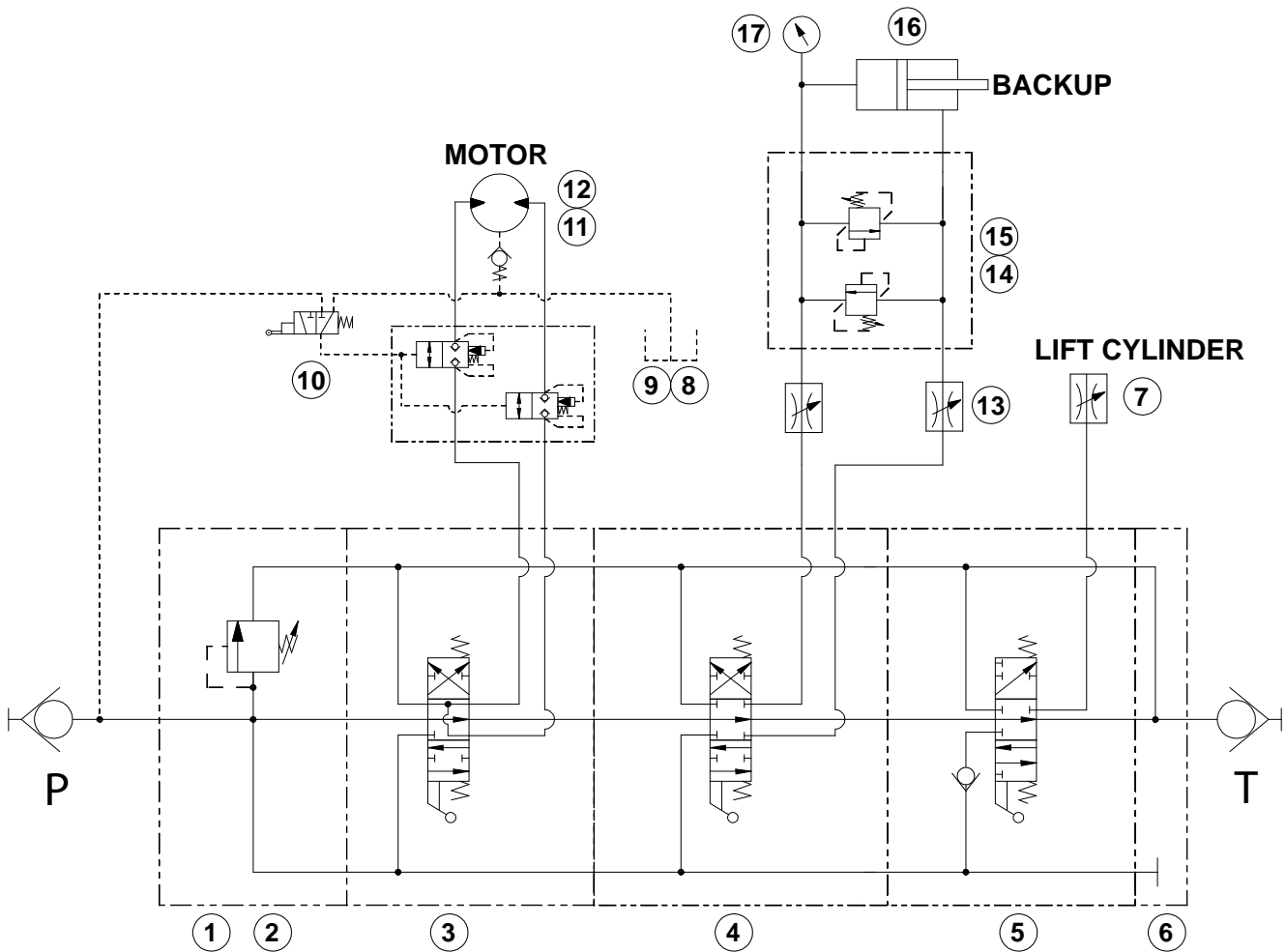

ILLUSTRATION 2.E.1: KT13625 TONG & FARR® BACKUP HYDRAULIC SCHEMATIC

Item	Description	Part Number	Page
1	Inlet Valve, DVA35-A880	10-9016	
2	Relief Valve, DVA35-MMRV-1	10-0010R	
3	Motor Section, DVA35-MA8	10-9014	
4	Backup Section, DVA35-DA8, SAE PORT	10-9019	
5	Lift Cylinder Section, DVA35-SA8, (1" ORB PORT)	10-9015	
5A	Lift Cylinder Section, CE-Marked Tongs Only	10-9019	
6	Outlet Section, DVA35-TR99, SAE PORT	10-0086	
6A	Outlet Section, DVA35, Pressure Beyond	08-1825	
7	Flow Control Valve	08-9062	
8	LKHC-XDN Pilot-To-Operate Cartridge Valve	08-1625	
9	Safety Door Valve Block	101-0727	
10	Safety Door Switch	08-0337	
11	Check Valve	02-9022	
12	Rineer GA15-15 Hydraulic Motor	87-0112	
	Rineer GA15-13 Hydraulic Motor (Lightweight model)	87-0110	

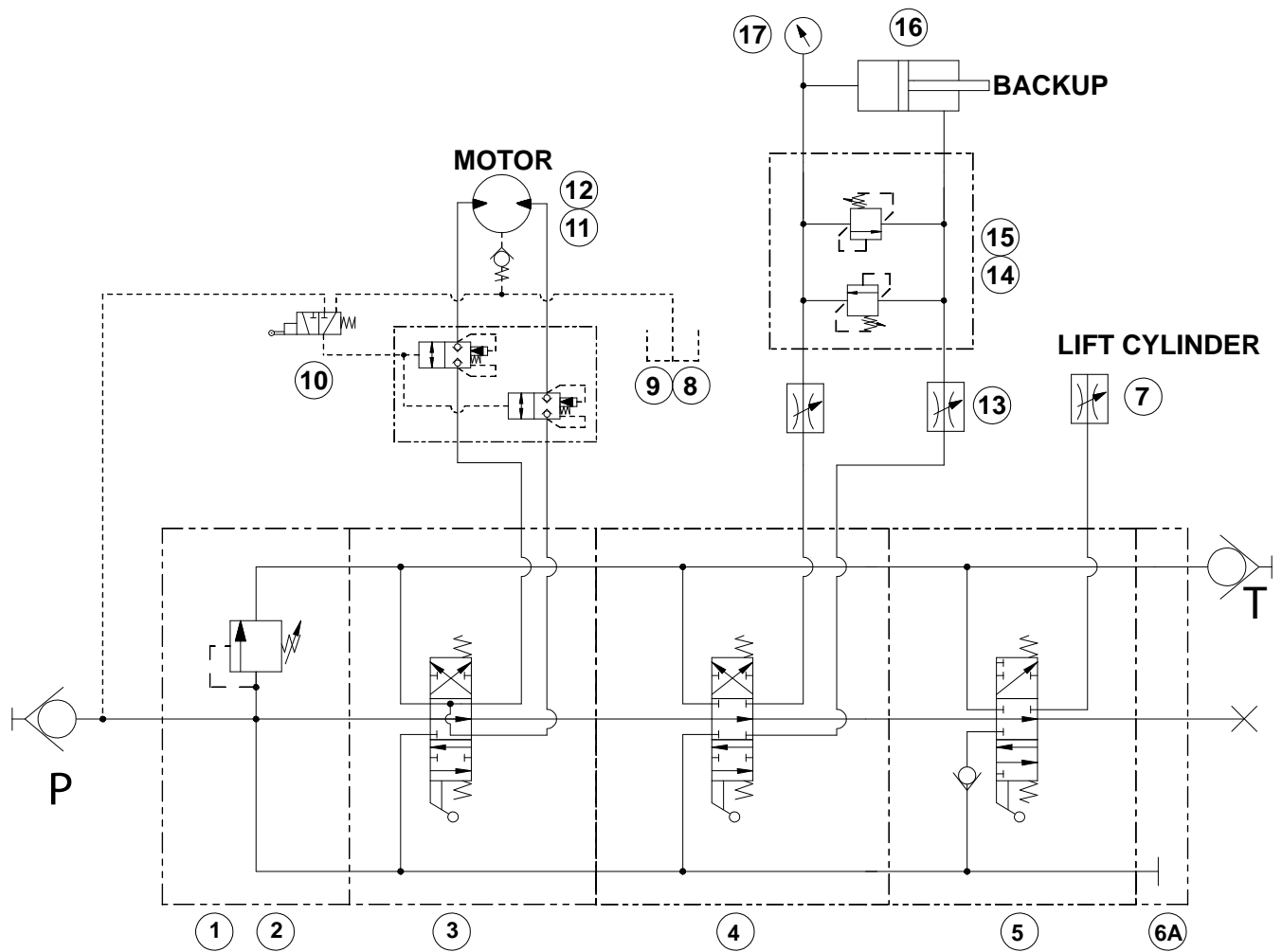

ILLUSTRATION 2.E.2: KT13625 TONG & FARR® BACKUP HYDRAULIC (CLOSED CENTRE)

If your tong hydraulics are configured as “closed centre” a “power beyond” outlet section will be used. Refer to the schematic above, and to the outlet section information on pg. 7.25.

Item	Description	Part Number	Page
13	Flow Control Valve	08-0089	
14	Relief Valve Block	08-0096	
15	Relief Valve	08-0095	
16	Backup Cylinder	1364-902	
17	3000 psi Pressure Gauge	02-0245	
18	Lift Cylinder Orifice (CE-Marked Tongs Only)		

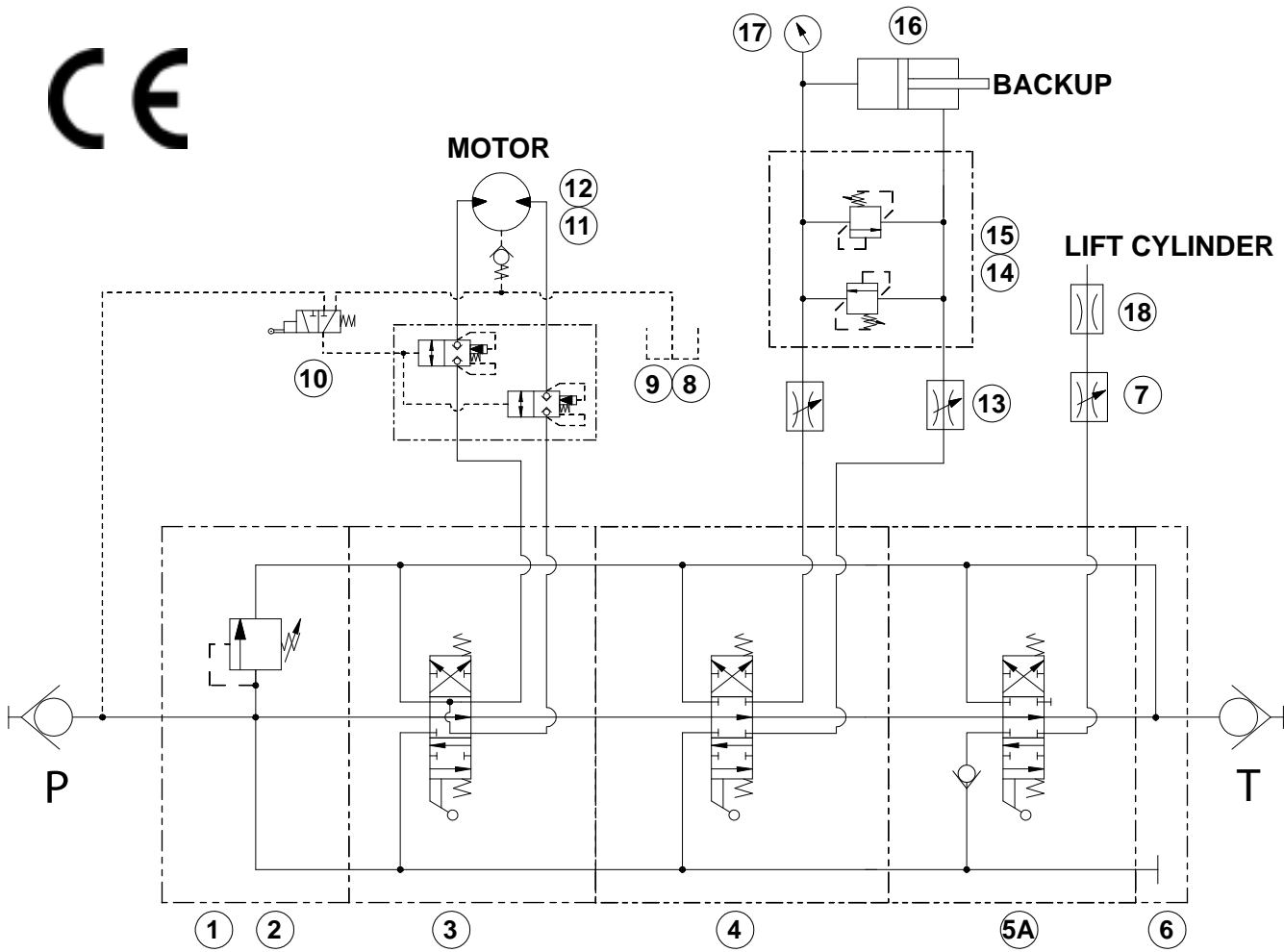

ILLUSTRATION 2.E.3: KT13625 TONG & FARR® BACKUP HYDRAULIC SCHEMATIC (CE MARKED)

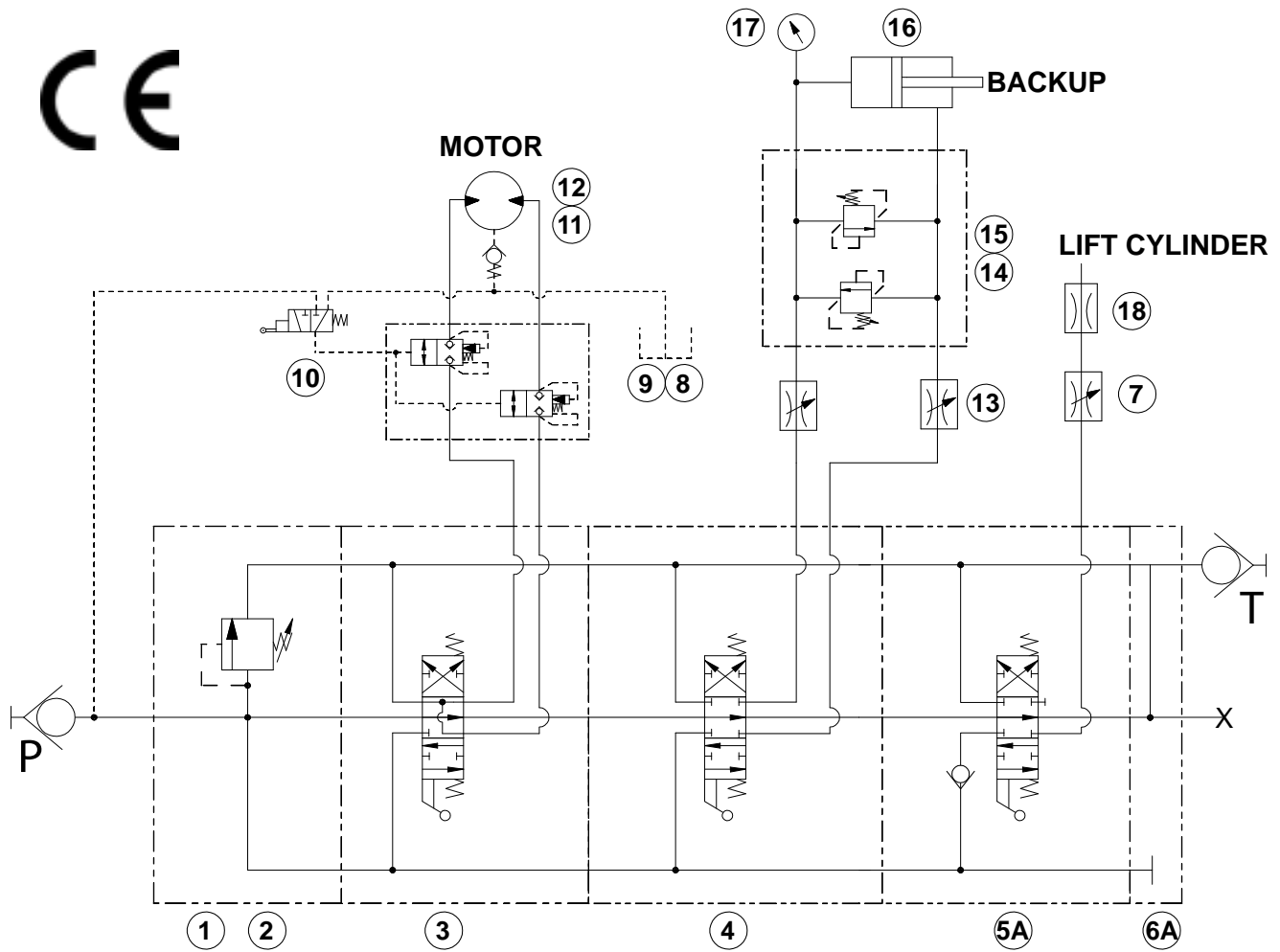

ILLUSTRATION 2.E.4: KT13625 TONG & FARR® BACKUP HYDRAULIC (CLOSED CENTRE, CE MARKED)

2. Hydraulic Component Identification

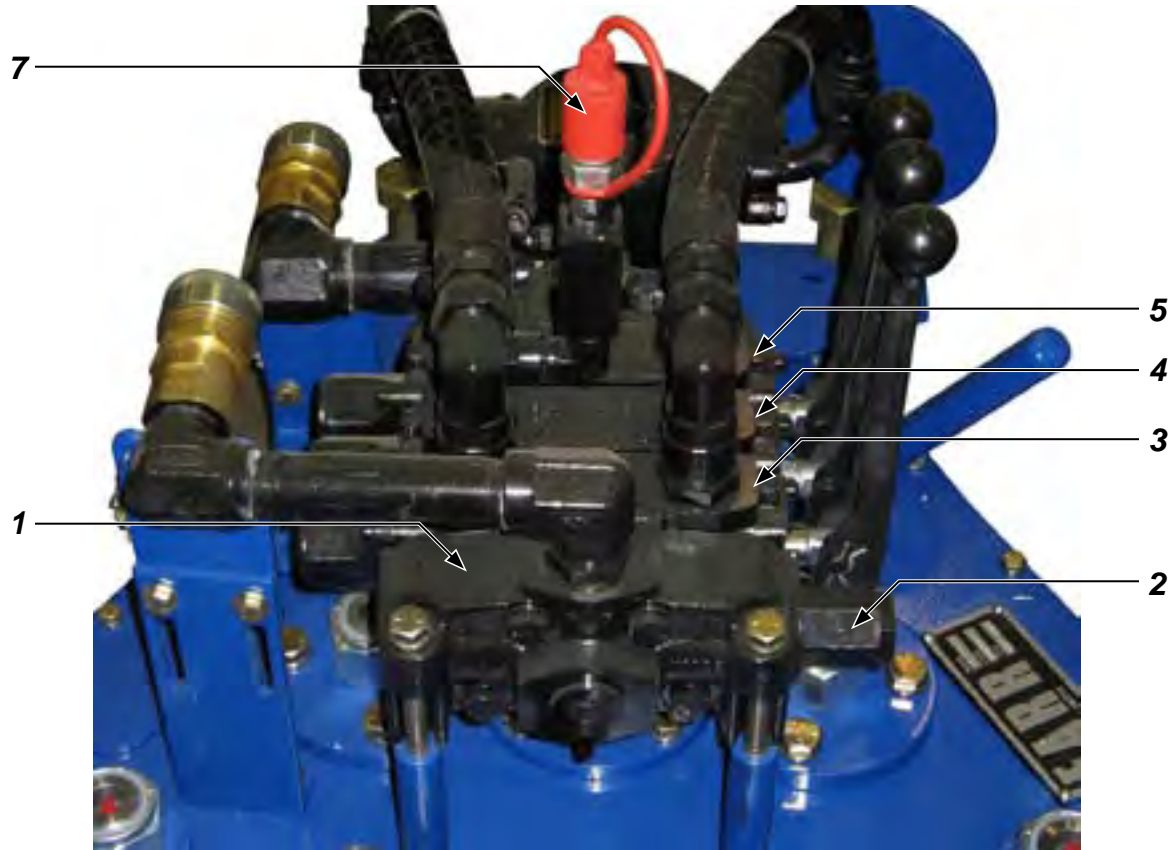

ILLUSTRATION 2.E.5: KT13625 TONG & FARR® BACKUP HYDRAULIC COMPONENT ID 01



ILLUSTRATION 2.E.6: KT13625 TONG & FARR® BACKUP HYDRAULIC COMPONENT ID 02



ILLUSTRATION 2.E.7: KT13625 TONG & FARR® BACKUP HYDRAULIC COMPONENT ID 03

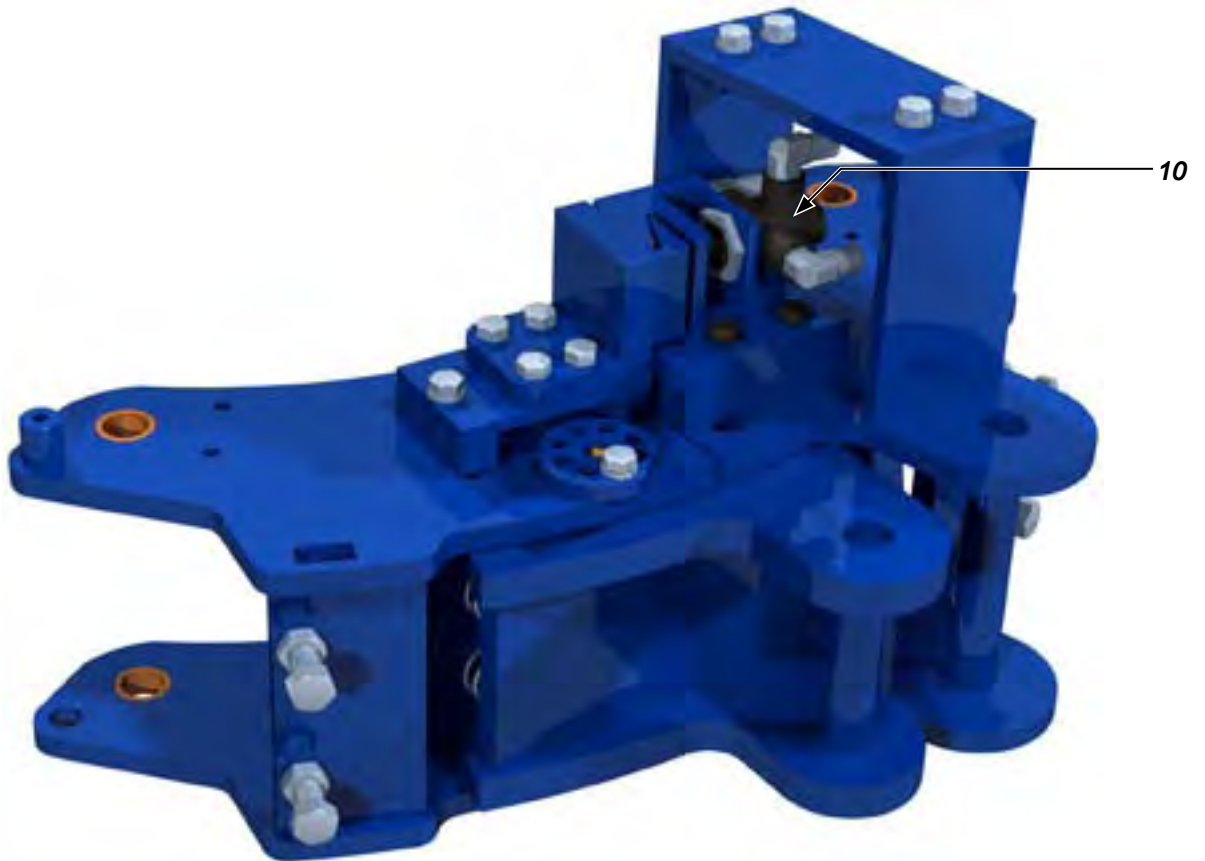

ILLUSTRATION 2.E.8: KT13625 TONG & FARR® BACKUP HYDRAULIC COMPONENT ID 04

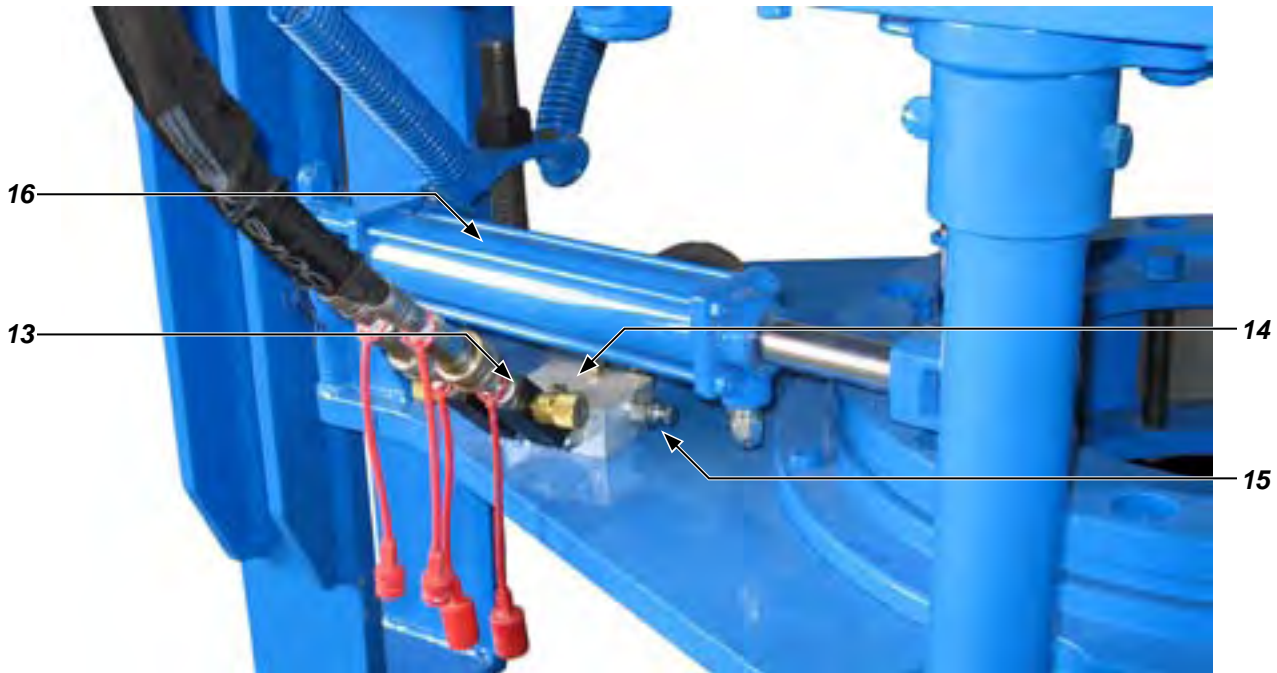

ILLUSTRATION 2.E.9: KT13625 TONG & FARR® BACKUP HYDRAULIC COMPONENT ID 05

3. Main Hydraulic Connections

A pair of hydraulic lines - a 1" supply line and a 1-1/4" return line - connect the tong to the power unit (see illustration below). Ancillary devices (hydraulic motors, hydraulic cylinders, etc.) are connected through the valve block.

Perform any hydraulic connection when the power unit is not running, or when the hydraulic pump is disengaged. The possibility of error in inter-changing the high pressure supply hose and the low pressure return hose has been eliminated, because the supply side coupling is smaller than the return side.

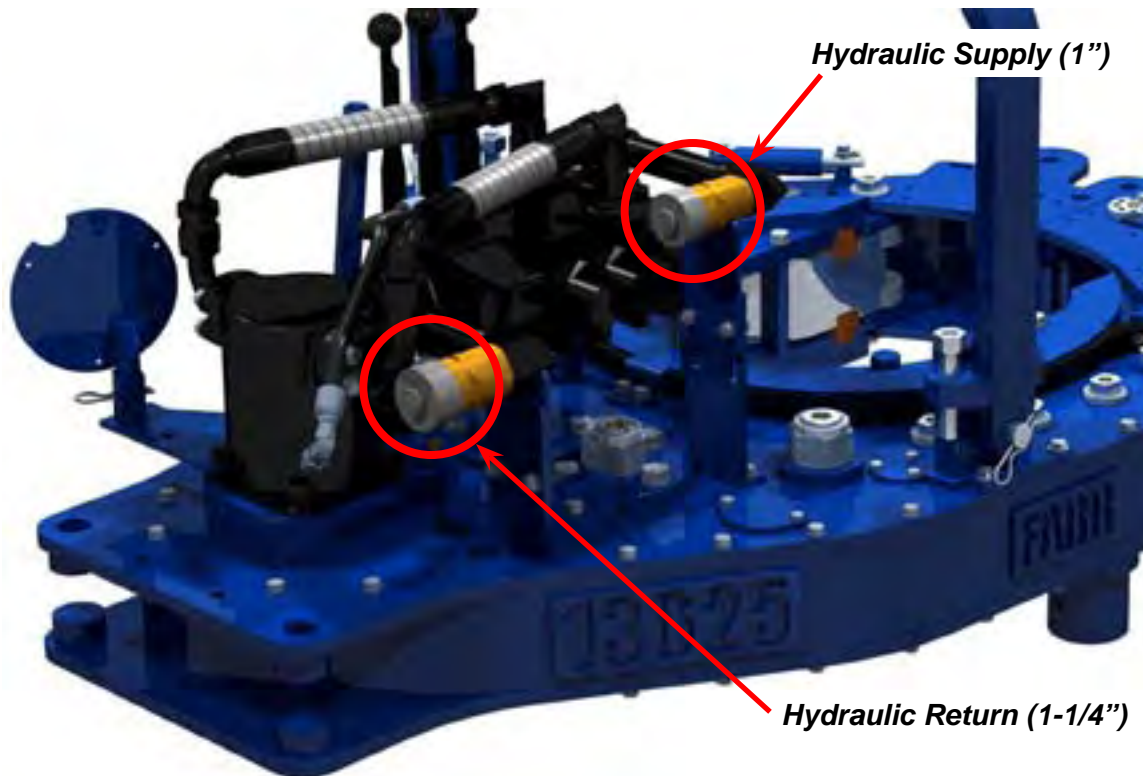

ILLUSTRATION 2.E.10: KT13625 TONG & FARR® BACKUP HYDRAULIC CONNECTIONS 01

Main Hydraulic Connections (Continued):

These hose couplings are self-sealing, and care should be taken to ensure complete engagement to prevent partial closure of the check valve in the coupling. Ensure that the nut (female) side is completely made up onto the male connector - there is a line on the male fitting that indicates complete make-up. Snug the female fitting right up to the line.

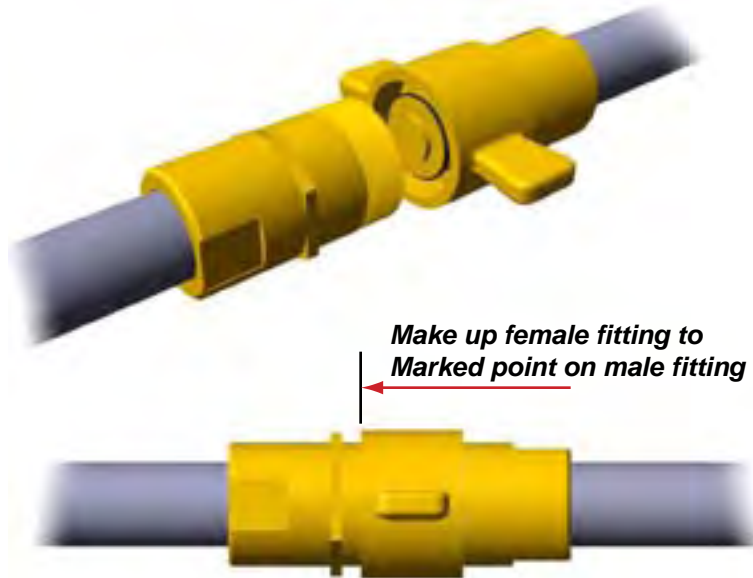

ILLUSTRATION 2.E.11: KT13625 TONG & FARR® BACKUP HYDRAULIC CONNECTIONS 02

Inspect these connections upon activation of the power unit. Leaking components must be repaired before releasing the tong to the operational environment. Deactivate the power unit and de-pressurize the hydraulic system according to the procedure in Section 3.D. Disconnect the main hydraulic connections and inspect all four connectors (two male, two female) for damage or debris. If the connectors cannot be cleaned or easily repaired, McCoy recommends replacement of the leaking connector. Note that damage to one of the connectors may have caused damage to its mate.

Turn off power unit and depressurize hydraulic system before disconnecting the main hydraulic lines under normal working conditions. See Section 3.D for hydraulic system depressurization. McCoy recommends placing protective caps over the exposed connectors to protect them from water and impact damage.



ALWAYS TURN OFF HYDRAULIC POWER AND DEPRESSURIZE HYDRAULIC SYSTEM BEFORE DISCONNECTING MAIN HYDRAULIC LINES.

4. Hydraulic Circuit Description

The main hydraulic power source supplies hydraulic fluid to the hydraulic valve block inlet section (Item 1 on the hydraulic schematic and on page 2.7) through a 1" threaded positive-shutoff connection. Hydraulic fluid circulates through the inlet section, the motor control section (Item 3 on the hydraulic schematic and on page 2.7) and the outlet section (Item 4 on the hydraulic schematic and on page 2.7) at maximum tong pressure before returning to the hydraulic fluid reservoir (the "tank") through a 1-1/4" threaded positive-shutoff connection. The relief valve (Item 2 on the hydraulic schematic and on page 2.7) is factory adjusted to limit the maximum operating pressure of the tong to that which will allow maximum torque. Maximum operating pressure and maximum torque are listed in the specifications on page 1.3.

Actuating the valve handle on the motor control section directs hydraulic fluid to the hydraulic motor (Item 9 on the hydraulic schematic and on page 2.7), through the safety door relief valve block (Items 5 & 6 on the hydraulic schematic and on page 2.7), causing rotation of the motor. During normal operation pilot pressure from the safety door switch (Item 7 on the hydraulic schematic and on page 2.8) directs pilot pressure to actuate the safety door check valves, allowing full hydraulic power to the motor. The configuration of the plumbing between the motor valve section and the motor determines the direction of rotation for a given valve action. McCoy Drilling & Completions | FARR normally configures the plumbing on this tong so that pushing the valve control handle towards the centre of the tong supplies hydraulic pressure to the "clockwise rotation" side of the motor, which is the desired direction of rotation for making up a tubular connection. Conversely, pulling the valve control handle towards the operator supplies hydraulic pressure to the "counter-clockwise rotation" side of the motor, which is the desired direction of rotation for breaking out a tubular connection. Releasing the valve handle enables the valve to go to a neutral position, directing all hydraulic fluid to the outlet section and "back to tank". A check valve (Item 8 on the hydraulic schematic and on page 2.7) installed on the case drain line between the motor and the main tank return line, or the internal case drain, protects the motor from excess pressure in the event of blockage in the tank line.

Hydraulic Circuit Description (continued):

Actuating the valve handle on the lift cylinder section directs hydraulic fluid to the lift cylinder, which is connected to the master link on the rigid sling and provides raising and lowering functions to the tong and backup assembly. Although the lift cylinder is designed to be a double-acting cylinder, normally only the "lift" side is connected to hydraulic pressure from the lift cylinder valve. Actuating the lift cylinder valve in the "lower" direction provides a path to tank for the hydraulic fluid in the lift cylinder and allows the load suspended on the lift cylinder to force the hydraulic fluid from the cylinder, through the valve. In other words the "lowering" action is a function of gravity, not active hydraulics. The position of the lift cylinder valve controls the rate at which the cylinder lowers the tong and backup assembly. An adjustable needle valve on the pressure line to the lift cylinder allows an operator to set the rate at which hydraulic fluid is supplied to the lift cylinder, thus controlling the rate at which the cylinder raises and lowers. A breather port installed in the opposite side of the lift cylinder allows the cylinder to breathe as the piston in the lift cylinder moves. The configuration of the plumbing between the lift cylinder valve section and the cylinder determines the action of the lift cylinder for a given valve action. McCoy Drilling & Completions | FARR normally configures the plumbing on this tong so that pulling the valve control handle towards the operator supplies hydraulic pressure to the lift cylinder, which causes the cylinder to retract, thus providing a lifting action. Conversely pushing the valve control handle towards the centre of the tong allows a path back to tank, which allows gravity to extend the cylinder and lowers the equipment. Allowing the handle to go to neutral stops all hydraulic fluid movement to or from the lift cylinder.



All CE-marked tongs are configured so that pushing the lift cylinder control valve handle toward the centre of the tong supplies hydraulic pressure to the lift cylinder, retracting the cylinder and causing the equipment to lift, while pulling on the lift cylinder control valve handle (toward the operator) will cause the equipment to lower. This valve handle action applies to all CE-marked tongs and is irregardless of control valve bank orientation.

A speed-limiting orifice is installed in place of a breather on all CE-marked lift cylinders. This orifice limits the rate at which the equipment will lower in the event of equipment failure (a ruptured hydraulic hose, for example).

Actuating the valve handle on the backup control section directs hydraulic fluid to the double-acting backup clamping cylinder. This is not proportional control, meaning that actuating the control valve enables a fixed hydraulic output to the cylinder. The configuration of the plumbing between the backup valve section and the backup cylinder determines the clamping action of the backup cylinder for a given valve action. McCoy Drilling & Completions | FARR normally configures the plumbing on this tong so that pushing the valve control handle towards the centre of the tong clamps the backup for make-up operations, and pulling the valve control handle toward the operator clamps the backup for break-out operations. Adjustable needle valves on each backup cylinder line allows the operator to set the rate at which hydraulic fluid is supplied to the backup cylinder, thus controlling the rate at which the cylinder clamps and un-clamps. Adjustable relief valves on each backup cylinder line allows the operator to set the clamping pressure for both make-up and break-out operations.

Hydraulic fluid at maximum tong pressure flows from the valve inlet section to the safety door switch. During normal operation the plunger on the safety door switch is depressed when the tong door is closed, directing a hydraulic pilot signal to both safety door relief valves (Item 5 on the hydraulic schematic and on page 2.7). This pilot pressure actuates the safety door check valves, allowing full system pressure to the motor when the motor control valve is manipulated. Releasing the plunger on the safety door switch by opening the tong door diverts all hydraulic fluid from the safety door switch to the tank line, interrupting pilot pressure to the safety door check valves. The relief valves close, immediately inhibiting system pressure to the motor. Full hydraulic power to the motor cannot be restored until the plunger on the safety door switch is depressed by fully closing the tong door.

F. TONG JAW AVAILABILITY & INSTALLATION**1. Jaw Availability**

The following table lists all jaw die kits that are available as standard stocked sizes for this model of tong. McCoy Drilling & Completions | Farr offers a good selection of standard jaw sizes. However, please note that McCoy can custom-engineer and manufacture any size of jaw within the range of the tong. Jaw systems are available to allow use of die inserts intended for specialized applications. Call our sales office for information on jaw and die systems designed for higher or lower grip, or non-marking applications.

The table lists standard contoured, flat and wraparound die inserts that are available as spare parts. However, a wide variety of diamond-tooth, GRITFACE®, and wrap-around fine-tooth dies are available for specialized applications. Please refer to our website for complete information:

<http://www.mccoysglobal.com/dies-inserts>



**USE OF ALUMINUM DIES IS FORBIDDEN
ON CE-MARKED EQUIPMENT**

Jaw Availability (continued):

Description	Part Number	Description	Part Number
3-1/2" Jaw Die Kit ⁽¹⁾	997-WJK-350	7" Jaw Die Kit	997-JDK-310
4" Jaw Die Kit ⁽²⁾	997-WJK-550	7-5/8" Jaw Die Kit	997-JDK-315
4-1/2" Jaw Die Kit ⁽³⁾	997-WJK-550	8-5/8" Jaw Die Kit	997-JDK-320
4-1/2" Jaw Die Kit ⁽⁴⁾	997-JDK-290	9-5/8" Jaw Die Kit	997-JDK-325
4-3/4" Jaw Die Kit	997-JDK-291	10-3/4" Jaw Die Kit	997-JDK-330
5" Jaw Die Kit	997-JDK-295	11-3/4" Jaw Die Kit	997-JDK-335
5-1/2" Jaw Die Kit	997-JDK-300	12-3/4" Jaw Die Kit	997-JDK-337
6" Jaw Die Kit	997-JDK-306	13-3/8" Jaw Die Kit	997-JDK-340
6-5/8" Jaw Die Kit	997-JDK-305	13-5/8" Jaw Die Kit	997-JDK-510

⁽¹⁾ Wraparound jaw die kit uses insert Part # 12-2006 **NOTE: THIS JAW IS TORQUE-LIMITED TO 9000 LBS-FT**

⁽²⁾ Wraparound jaw die kit uses multi-range jaw (997-WJK-550) and wraparound insert Part # 12-2007.

⁽³⁾ Wraparound jaw die kit uses multi-range jaw (997-WJK-550) and wraparound insert Part # 12-2009.

⁽⁴⁾ Optional 4-1/2" jaw die kit uses flat jaw die insert Part # 13-0008-314-0.

All remaining jaw die kits use flat die Part # 13-0008-314-0.



DO NOT EXCEED 9000 LBS-FT OF TORQUE WHEN USING THE 3-1/2" JAW DIE KIT

2. Jaw / Jaw Die Removal



JAWS MAY PRODUCE METAL SLIVERS. WEAR STURDY GLOVES WHEN REMOVING AND INSTALLING JAW DIE KITS.



DO NOT ACCESS ROTATING COMPONENTS UNLESS HYDRAULIC POWER SUPPLY HAS BEEN DEACTIVATED OR ISOLATED.

- Push against the front of the jaw to cause the assembly to swivel around the pivot bolt.
- Remove the die retainer, which is most often a flanged machine screw.
- Remove the rear die - if it does not loosen it may have to be lightly tapped out of the jaw.
- Push against the rear of the jaw to cause the assembly to swivel the opposite way around the pivot bolt.
- Remove the retainer for the front die, and remove the front die

Reverse this procedure to install new jaw dies.

(See illustration 2.F.1 next page)

Jaw / Jaw Die Removal (continued):

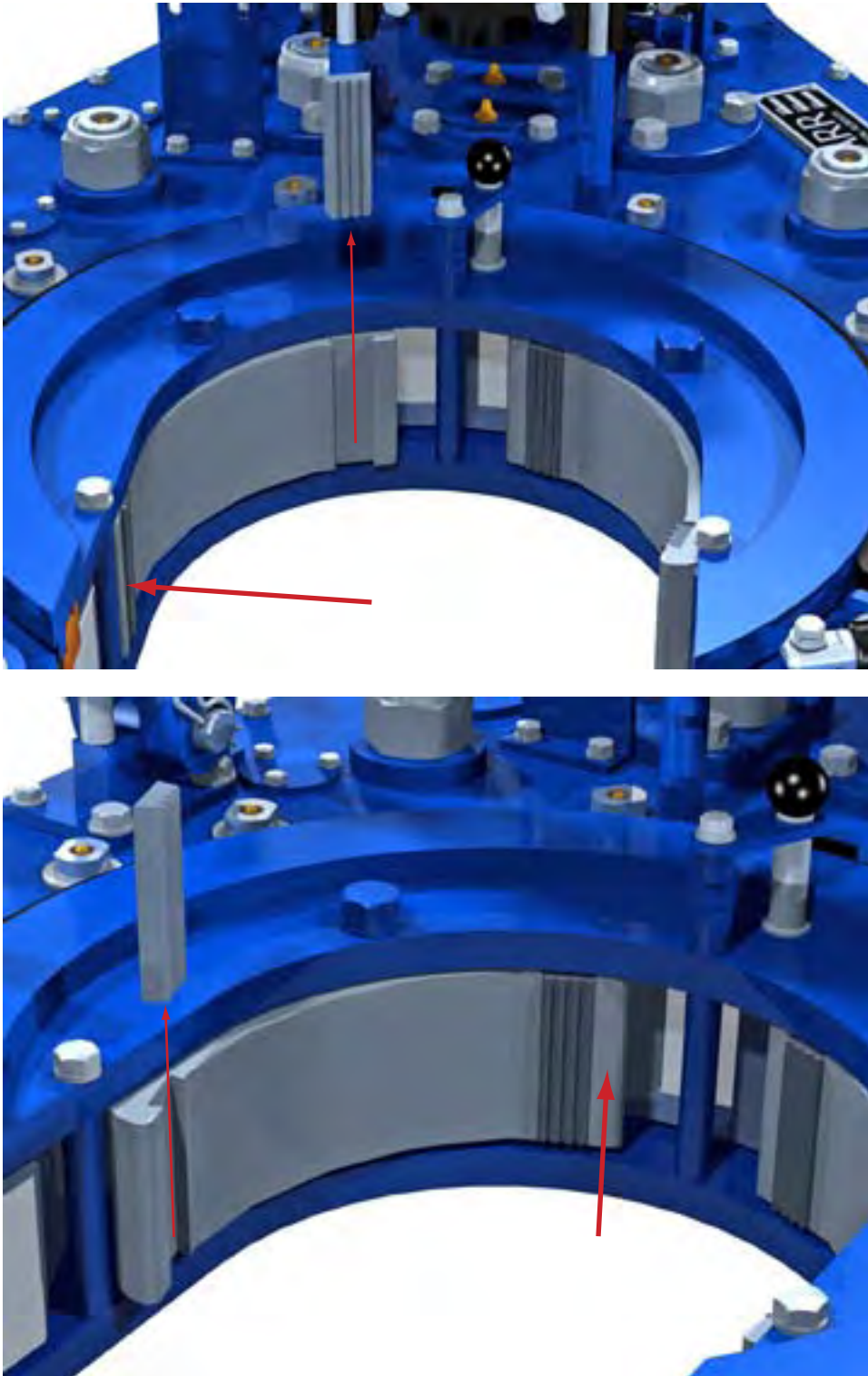

ILLUSTRATION 2.F.1: JAW DIE REMOVAL

Jaw / Jaw Die Removal (continued):

The tong jaws will often require removal to change jaw size or replace worn jaw die inserts. Open the tong door to disable tong rotation (rotation is inhibited by safety door systems). Support the jaw being removed from the bottom, and use a wrench to loosen and remove the jaw pivot bolt. Slide the jaw away from the rotary gear towards the centre of the cage plate assembly, and lift clear of the tong (see Illustration 2.F.2). Repeat for the other jaw.

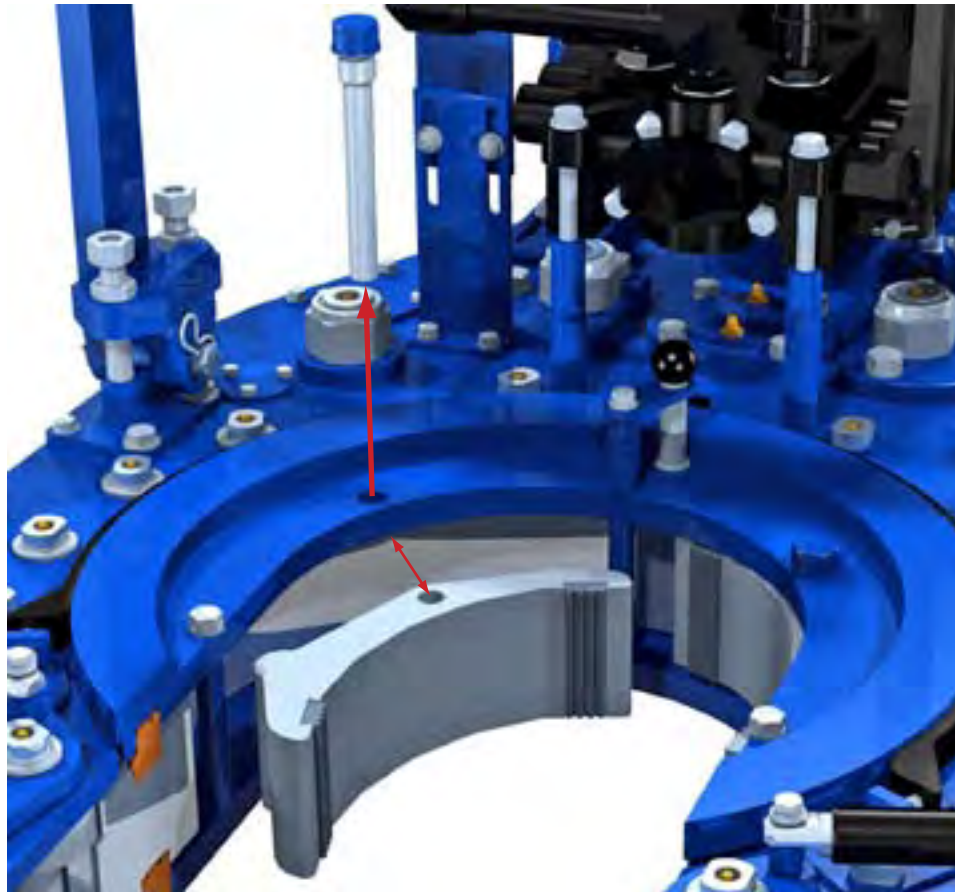

ILLUSTRATION 2.F.2: JAW REMOVAL

Once the jaw has been removed the jaw dies may be replaced by removing the keeper screw above the die, and tap the die from jaw using a hammer. Replace the die, tapping it into place if necessary, and replace the keeper screws.

3. Backup Jaws

The jaw die kits used in the Farr backup are identical to those used in the tong (see Pg. 2.19). Follow the same removal and installation instructions as for the tong jaw die kits.

G. TONG RIG-UP & LEVELING**1. Suspension & Restraint**

Suspend the tong and backup from a location as near to the centre of the drill rotary as possible, and from a location high enough on the mast to ensure easy handling. The lower the point from which the tong is suspended, the more effort will be required to move the tong to and from the connection point.

The suspension line may be extended over a pulley and balanced by a counterweight equal to the weight of the tong and backup, or simply tied off in the derrick to form a dead line. When using a dead line arrangement it is necessary to use a FARR spring hanger assembly (see specification page for recommended spring hanger). This spring hanger compensates for the downward movement of the casing as the thread is made-up, and imparts additional force to the suspension cable:

- a "single spring" hanger typically applies 420 lbs. (191 kg.) to the suspension line for every inch of thread made up
- a "double spring" hanger typically applies 840 lbs. (382 kg.) to the suspension line for every inch of thread made up

If you do not know which specific spring hanger is in use, check the specification page in this manual for information on the recommended spring hanger for this application. McCoy Drilling & Completions will not guarantee or specify spring hangers other than what has been supplied by McCoy.

Many applications use a lift cylinder for adjusting the height of the tong. Ensure the weight of the lift cylinder is known if it has not been included in the total weight of the tong.

All forces upon the suspension line must be considered when calculating necessary strength of the suspension line. The weight of the tong, the weight of the lift cylinder, the weight of the spring hanger, and the force imparted on the suspension line by the spring hanger must all be added together in order to arrive at the total force supported by the suspension line. Select your suspension line based upon the total force and the margins of safety dictated by the policies of your company and by established engineering practices. Ultimately, calculating the force on the suspension line and selection of the suspension line is the complete responsibility of the customer.

McCoy Drilling & Completions recommends using dual backup (snub) lines of sufficient strength to withstand the force imparted by the maximum rated torque of the tong and backup assembly in use. The snub lines will arrest uncontrolled movement of the tong and backup in the event slipping of the backup jaws. Calculate the force on the snub lines by dividing the maximum torque of the tong by the tong's torque arm (expressed in feet). For example, a 35,000 lbs-ft tong with a 36 inch (3 ft) torque arm will generate 11667 lbs of force against the snub line. Select your snub lines based upon the total force and the margins of safety dictated by the policies of your company and by established engineering practices. Ultimately, calculating the force on the snub line and selection of the snub line is the complete responsibility of the customer.

Snub lines must be securely connected to the rear of the tong and backup assembly, and tied off to a suitable anchor.



MCCOY DRILLING & COMPLETIONS ACCEPTS NO RESPONSIBILITY FOR DESIGNING AND SELECTING AN ADEQUATE SUSPENSION AND RESTRAINT SYSTEM FOR YOUR DRILLING EQUIPMENT



ALL SELECTED FASTENERS, SHACKLES, CLAMPS, ETC. USED FOR CONSTRUCTING THE SUSPENSION AND SNUB LINES MUST BE RATED FOR THE CALCULATED FORCES.

2. Tong Leveling

The tong must be leveled side-to-side and front-to-rear before placing into service. The following guidelines will assist you when leveling your tong.



FAILURE TO PROPERLY LEVEL TONG MAY RESULT IN JAW SLIPPAGE OR FAILURE OF JAW COMPONENTS

- Place a level axially (side to side) across the tong, ensuring that it is parallel with the surface of the tong. Use a thin wrench on the flat of the adjusting helix to rotate the helix, forcing the lift link to move towards the outer supports of the sling. The 1" jam nut on the pin may have to be slightly loosened to allow the helix to rotate. Adjust the helix until the level shows that the tong is level side-to-side - retighten the nut if necessary

Tong Leveling (continued):

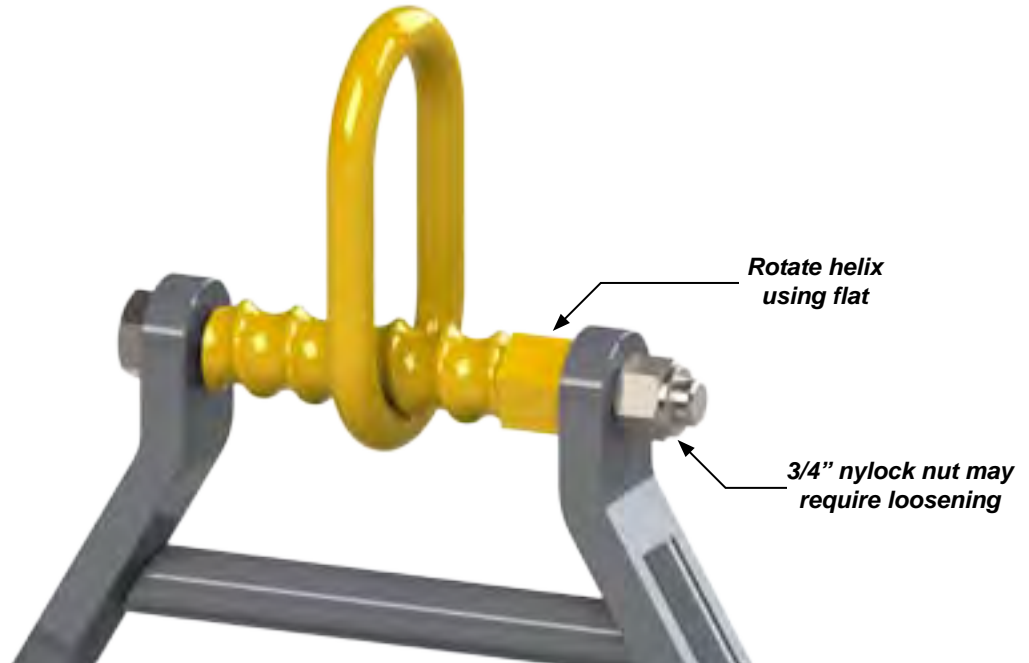

ILLUSTRATION 2.G.1: TONG LEVELING (SIDE-TO-SIDE)



ONLY USE THE MASTER LINK TO SUSPEND THE TONG ASSEMBLY. THE RIGID SLING IS DESIGNED TO BE USED FOR VERTICAL LIFTING ONLY.

Tong Leveling Continued:

- ii. Place a level lengthwise (front to back) along the tong, ensuring that it is parallel with the surface of the tong. Loosen the 3/4" jam nuts on the adjusting bolts on rigid sling brackets. Completely loosen the adjusting bolts. Turn front or rear adjusting bolt equally on each hanger lug until tong hangs level front-to-back. Lock adjusting bolts in place with the jam nuts.

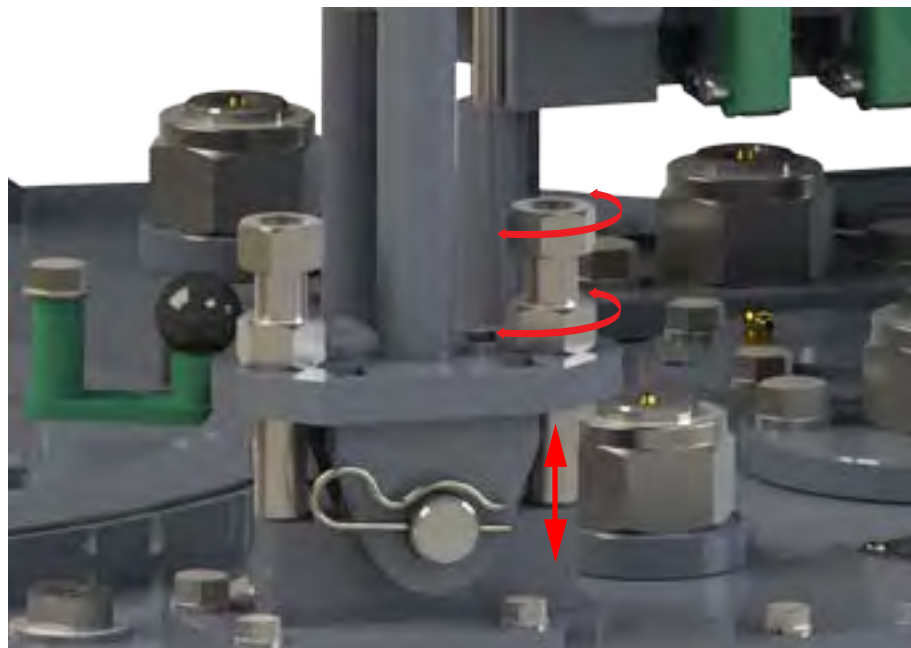

ILLUSTRATION 2.G.2: TONG LEVELING, FRONT-TO-BACK

3. Load Cell Configuration

The backup is directly coupled to the compression load cell via the backup body paddle. The load cell hanger is simply hung on the paddle and secured through the top of the "U" by a bolt and washer set, and in normal operation does not need to be adjusted or removed. The assembly in the first of the following two illustrations has been configured in the "make-up" configuration; to convert the assembly to the "break-out" configuration remove the bolt and washer set securing the load cell holder to the paddle, and move the entire assembly to the other side of the paddle.

Load cell configured for make-up operations



ILLUSTRATION 2.G.3: LOAD CELL CONFIGURATION, MAKE-UP

Load cell configured for break-out operations

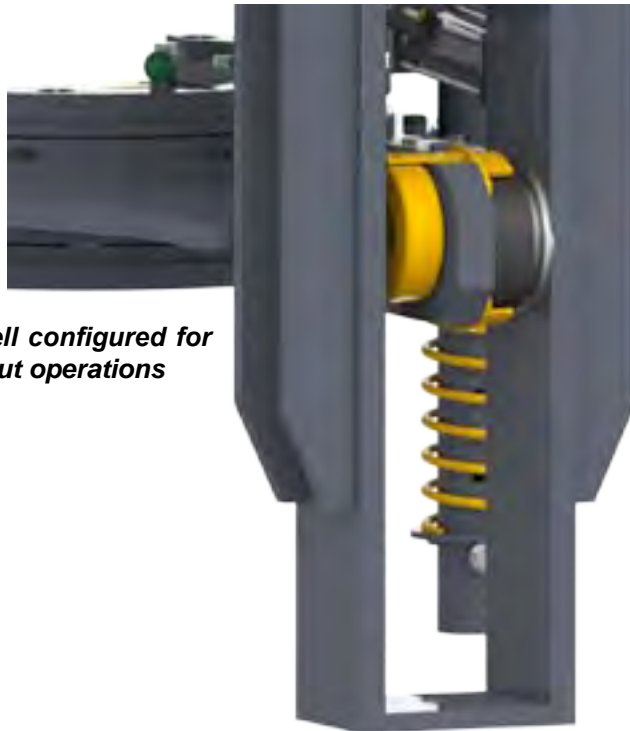

ILLUSTRATION 2.G.4: LOAD CELL CONFIGURATION, BREAK-OUT

H. TONG OPERATION

1. Operator Training

Many companies set qualification standards that must be met before equipment may be operated without supervision. McCoy Drilling & Completions recommends operator training, which typically consists of operation of the equipment under the supervision of a trained equipment operator until a satisfactory level of competence is achieved. Typical operator training should include:

- Introduction to and general description of equipment
- Technical specifications and performance data
- Operating instructions
- Control systems and interlocks
- Operating hazards
- Checks and inspections

2. Operator Safety

McCoy recommends that a hazard assessment of the work area be performed by a designated safety representative before commencing operations. A designated safety representative is responsible for verifying that all operators have adequate equipment and safety training.

The safety door system is the primary device protecting the tong operator and nearby personnel from the rotary gear. Confirm the correct operation of the safety door before every job. Never disable the safety door device.

	<p>Inspect anti-tamper devices on safety door components before beginning job. Equipment showing signs of tampering on any safety system must be immediately removed from service and tested. Anti-tamper devices must be restored before allowing equipment to be released to an operating environment.</p>
---	--

The area surrounding the tong operating area must be clutter-free and free from tripping hazards, or protruding objects that may snag hydraulic hoses on the tong, backup, lift cylinder, or torque measurement system. Operating surface or drill floor must be kept free of slipping hazards like grease, oil, water, etc.

Adequate lighting of the work area is required. All warnings, labels, gauges, and signs must be clearly visible

The components of the tong commonly manipulated or requiring control input are painted green, and are safe for continuous handling. Areas painted yellow are designated as hazardous areas, and contact with those areas must be avoided during operation. Always wear all personal protective equipment (PPE) specified by your company's HSE policy, and follow all of your company's safety guidelines.



ALWAYS WEAR APPROVED PERSONAL PROTECTIVE EQUIPMENT (PPE) WHEN OPERATING HYDRAULICALLY-POWERED EQUIPMENT.

Ensure hydraulic power is deactivated and tong hydraulics are de-pressurized before disconnecting the main hydraulic lines. McCoy recommends depressurizing the tong hydraulic system before connecting or disconnecting quick-connect fittings.



DEPRESSURIZE EQUIPMENT BEFORE DISCONNECTING MAIN HYDRAULIC LINES.

3. Valve Operation

4-way proportional valves control operation of hydraulic devices on the tong assembly such as hydraulic motors and cylinders. When any one valve is "centered" or in the detent position, there is no hydraulic output from the valve. When the valve is pushed forward there is an effect, and when the valve is pulled back, there is an opposite effect. These valves feature proportional control, which means that further extension of the valve handle (thereby further opening the valve orifice) results in proportionally higher hydraulic output to the controlled device.

The illustrations on the following pages demonstrate the type and effect of the hydraulic valves with which this tong is may be equipped.

TONG MOTOR

This is a proportional valve. Pushing the valve handle forward will cause the tong motor to rotate in a clockwise direction (as seen from the top of the tong). This is the desired direction of rotation for making up a joint. Pulling the valve handle in the opposite direction results in counter-clockwise rotation, which is the desired direction of rotation for breaking out a joint. Releasing the valve handle will cause the tong to immediately stop rotation.

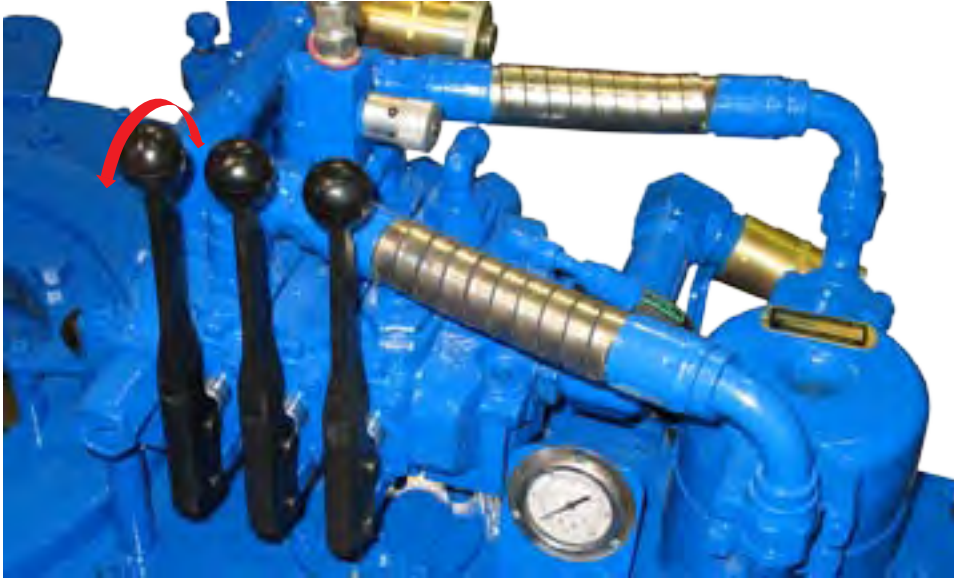
**ILLUSTRATION 2.H.1: MOTOR CONTROL VALVE****LIFT CYLINDER CONTROL VALVE**

This is a direct-acting valve. Pulling out on the valve handle will cause the lift cylinder to lift the tong vertically. Pushing in on the valve handle will cause the lift cylinder to lower the tong. Releasing the valve handle will immediately stop the lifting or lowering action.



Pushing on the lift cylinder control valve handle (toward the center of the tong) will cause the equipment to lift, while pulling on the lift cylinder control valve handle (toward the operator) will cause the equipment to lower. This valve handle action applies to all CE-marked tongs and is regardless of control valve bank orientation.

LIFT CYLINDER NEEDLE VALVE (See illustration 2.H.2)

This needle valve regulates hydraulic fluid flow to the lift cylinder. Closing the needle valve (rotating the knob clockwise) will increasingly restrict the flow rate of the fluid, resulting in slower actuation of the cylinder in both directions (lifting & lowering).

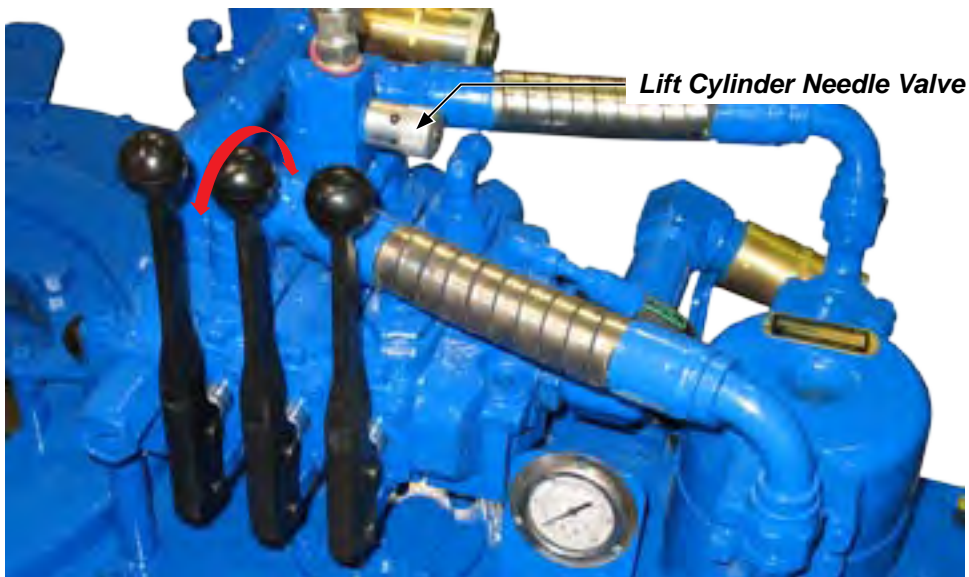
**ILLUSTRATION 2.H.2: LIFT CYLINDER CONTROL VALVE**

BACKUP

This is a two-way direct acting valve, without proportional control. Pushing the valve handle forward will cause the backup to engage. Pulling backward, towards the operator, reverses the operation.

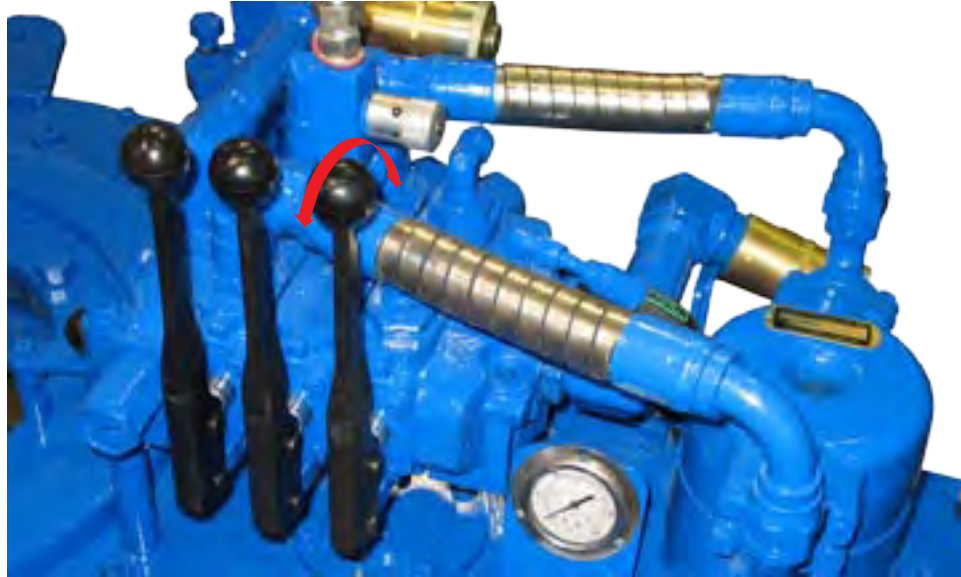

ILLUSTRATION 2.H.3: FARR® BACKUP CONTROL VALVE

4. Shifting Gears

The shifting shaft has three “detent” positions identifying the low speed/high torque position, the “neutral” or free-spinning position, and the high speed/low torque position. The detent strength may be adjusted by releasing the locknut on the detent tube and increasing or relaxing pressure on the detent spring. Ensure the locknut is tightened once the desired detent pressure has been set.

To shift to the high-speed gear, move the shifting handle DOWN from neutral position. To shift to the low-speed gear, move the shifting handle UP through the neutral detent to its HIGHEST position. Note that the high clutch gear or the low clutch gear may not be exactly aligned when shifting, so the operator may need to “bump” the motor control handle slightly to turn the main clutch gear shaft and shifting collar into alignment. The most effective way of achieving this is to apply a small amount of pressure on to the gear shift lever in the direction you want to shift the tong, ensuring the shifting collar will “catch” when the main clutch gear aligns with either the high or low clutch gear (see Illustration 2.1.3 next page)



DO NOT SHIFT TONG WHILE ROTATING THE MOTOR AND CAGE PLATE. CATASTROPHIC GEAR TRAIN FAILURE MAY RESULT.

**Move Shifting Handle
This Direction To Shift
To High Gear**

**Move Shifting Handle
This Direction To Shift
To Low Gear**



ILLUSTRATION 2.H.4: SHIFTING GEARS

5. Pre-Operational Checks

McCoy recommends that the following pre-operating tests be performed prior to releasing the tong assembly to a operational environment:

- a. Connect the tong to a hydraulic power source in a controlled environment. Ensure the power unit's operating parameters are within the specifications as identified on Pg. 1.3. Ensure the hydraulic connections from the power unit are properly and securely made up (see Section 2.E). Do not neglect to connect the motor drain line.
- b. Start the power unit as specified by the power unit operator's manual. Open the Bypass Valve on the hydraulic system, and inspect all pressure and return line hose connections to ensure correct and secure installation. A restriction in the pressure supply hose will result in high pressure within the power unit hydraulic system, which will activate the hydraulic governor and increase the engine speed to as high as maximum RPM. A restriction in the return line will result in high pressure within the power unit and the tong hydraulic system, causing engine speeds as high as maximum RPM, and possible failure of the motor seal.



A CLEARLY IDENTIFIED REMOTE POWER PACK EMERGENCY STOP MUST BE INSTALLED IN THE IMMEDIATE VICINITY OF THE TONG OPERATOR.

- c. Allow hydraulic system to warm by circulating fluid for about 10 minutes, then slowly close the bypass valve to allow hydraulic fluid to circulate through the hoses and tong. Ensure circulating pressure does not exceed 200 psi.
- d. Inspect all hydraulic hoses and connections on the tong. Immediately correct any hydraulic fluid leaks.
- e. Inspect all gauges. Replace leaking or cracked gauges, or any gauge not registering a reading.
- f. Confirm that all load-bearing pins and R-clip retainers are installed and in good condition (rigid sling pins, lift cylinder pins).
- g. Confirm all hydraulic hoses (with the exception of the supply & return to the backup) are securely fastened to the tong, and are not in contact with the cage plate or creating a snagging hazard.
- h. Ensure the tong door is securely closed before rotating tong.



DOOR MUST BE CLOSED AND SECURELY LATCHED BEFORE TONG ROTATION IN ORDER TO ASSURE THE SAFETY OF OPERATING PERSONNEL.

- i. Shift the tong to low gear (see Section 2.H.4) and rotate the tong slowly forward for approximately a minute. Stop the tong and then reverse the rotation direction for approximately another minute. Stop the tong, shift to high gear, and operate in high gear for approximately another minute. Stop the tong and rotate in the opposite direction in high gear for approximately another minute. If at any time abnormal operation is suspected (surging, grinding, squealing, or other noises deemed to be unusual, or failure to operate) discontinue operation of the tong and contact McCoy Drilling & Completions immediately.
- j. Re-inspect all hydraulic lines and connections on the tong, and correct all leaks.
- k. The safety door system is the prime protective measure separating the operator from the rotary gear, and must be in working condition when operating tong. Carefully inspect the safety door components, and test the operation of the safety door using the following procedure:
 - i. Keep non-essential personnel clear of the unit under test. This test procedure will only include two people: one to run the control valve and one to operate the door.
 - ii. Ensure the tong door is securely closed.
 - iii. Shift to LOW gear.
 - iv. Begin rotating the tong (direction of rotation is not important).
 - v. Open the tong door while the rotating the tong. The tong must immediately and completely stop rotating as soon as the door is opened.
 - vi. Continue to apply rotation control, and open & close the door throughout its complete range. Slowly close the door until it latches. Rotation must not begin until the door is completely closed and securely latched.

If the safety door does not operate as designed, the safety door switch may require adjustment, or further troubleshooting of the safety door system may be required. See Section 3.F.4 for safety door switch adjustment procedures, and Section 4.D for safety door troubleshooting instructions.

The safety door switch is protected from impact by a sturdy metal guard, painted yellow. This guard must be inspected before each use of the tong. All components of the guard must be in place, and all fasteners securing the guard must be intact and tight. Ensure wire ties (where applicable) on safety door components are present and secure, and do not show signs of tampering.



DO NOT OPERATE TONG WITH A MALFUNCTIONING OR NON-OPERATING SAFETY DOOR SYSTEM.

6. General Operational Comments

- a) Position rotary gear in contact with both idler gears when breaking out joints or collars where high torques are required.
- b) When making-up integral (shouldered) joints, it is essential to make up the last turn of the threads in low gear. This reduces the tendency of an instant stop or a sudden increase in torque, which induces extremely high stresses on the gear train.
- c) DO NOT employ the "snap break" method of breaking-out joints when pulling a string. By definition, the "snap break" method is a procedure used by some operators to break out connections, accomplished by leaving slack in the "jaw-pipe" engagement, and then quickly pulling the throttle valve control lever allowing the tong to snap into its loaded or high torque condition. Although this method is very effective in breaking out joints, the extremely high stress placed on the gear train frequently causes gear breakage.



THE "SNAP-BREAK" METHOD IS HAZARDOUS TO PERSONNEL AND EQUIPMENT

I. EXTREME COLD WEATHER OPERATION PROCEDURES

- 1) Consult the power unit engine operator's manual for all cold weather operating procedures and precautions.
- 2) Select gear and bearing lubricants that are compatible with expected climatic conditions.
- 3) Select hydraulic fluid that is compatible with expected climatic conditions.
- 4) Allow hydraulic fluid to circulate for approximately 20 minutes after starting the power unit, prior to activating the bypass valve to allow fluid to circulate to tong. If the power unit is equipped with an oil temperature gauge, ensure that the fluid has reached operating temperature as specified by hydraulic fluid data sheet.
- 5) Allow for adequate drying of moisture (prior to lubricating) when cleaning tong parts in cold weather.

J. MAKING AND BREAKING CONNECTIONS

THESE OPERATING PROCEDURES ASSUME THE USER HAS PROPERLY SET UP AND PREPARED THE EQUIPMENT FOR OPERATION AS PER SECTIONS 2D, 2E, AND 2F OF THIS MANUAL.

Set up and prepare your equipment for operation as per Section 2 of this manual Refer to the following sections:

- 2.D - Lift Cylinder Installation
- 2.E.3 - Hydraulic Connections
- 2.F - Tong Jaw Installation
- 2.G.1 - Tong Rig-up and Leveling (Suspension)
- 2.G.2 - Tong Rig-up and Leveling (Leveling)

Your tong and backup assembly should be properly suspended, connected to a hydraulic power source, and ready to make or break connections at this point.

1. Making A Connection

- a) Ensure hydraulic power supply to the tong is energized. The master link on the rigid sling must be used to suspend the tong. Do not suspend the tong directly from the rigid sling.



ILLUSTRATION 2.J.1: RIGID SLING MASTER LINK



THE MASTER LINK MUST BE USED TO SUSPEND THE TONG ASSEMBLY

- b) Ensure the backing pin is in the "makeup" position. From the front of the tong, the backing pin correctly configured for makeup will be in the 10 o'clock position (see Illustration 2.J.2 next page). If it is not, simply lift up and place in the correct position (see Illustration 2 next page). The cage plate opening must be aligned with the door opening when setting the backing pin position. Set the position of the backing pin on the backup in exactly the same fashion.

Making A Connection (Continued)



ILLUSTRATION 2.J.2: SETTING BACKING PIN TO "MAKE-UP" POSITION

- c) Properly configure the load cell for making up connections (see Section 2.G.3). Connect snub lines to the rear of the tong to arrest uncontrolled rotation of the assembly in the event of backup jaw slippage. The snub lines must be rated for the applied torque plus whatever safety margins stated by your own operating policies. The snub line connection points on the drill floor must be sturdy enough to absorb all applied forces. When making up joints the snub line is attached to the driller's side of the tong, which is the left side of the tong as seen from the rear. For accurate torque measurement the snub line must be perpendicular to the vertical, and perpendicular to the centre-line of the tong.
- d) Grasp the green tong door latch handle on the right-hand door assembly (on the left hand side as seen from the front) and pull the door to release the latch and open the door. (See Illustration 2.J.3). Opening the tong door will activate the safety door system and prevent rotation of the cage plate.



ILLUSTRATION 2.J.3: OPENING RH TONG DOOR

Making A Connection (Continued)

- e) Grasp the green tong door handle on the left-hand door assembly (on the right-hand side as seen from the front) and pull the door completely open. (See Illustration 2.J.4).

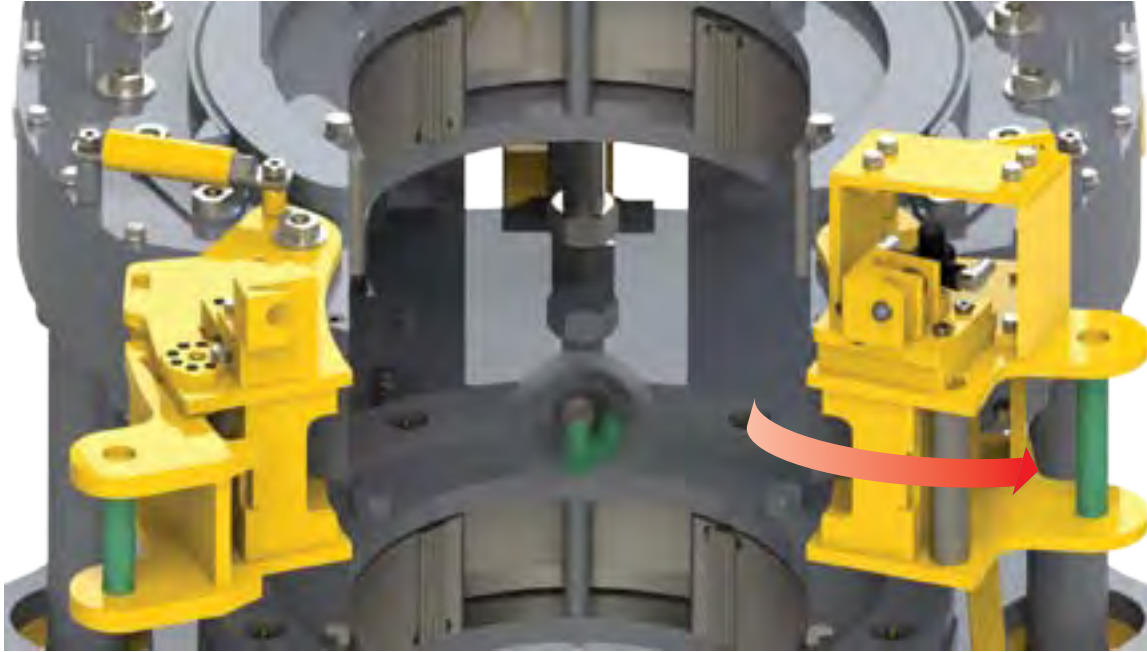

ILLUSTRATION 2.J.4: OPENING LH TONG DOOR

- f) Grasp the green tong door handle on the backup door weldment and pull the door completely open (See Illustration 2.J.5). As the backup door is opened the “kicker bar”, which is a component of the door weldment, will swing into the rotary opening. This kicker bar mechanically causes the backup door to swing shut as the tong and backup assembly is moved on to a pipe string.



ILLUSTRATION 2.J.5: OPENING BACKUP DOOR

Making A Connection (Continued)

- g) Actuate the lift cylinder control valve to lift the assembly from the drill floor. Pulling on the valve handle toward the operator will retract the lift cylinder to lift the assembly (see Illustration 2.J.4 below). Note that rig personnel are required to stabilize the tong and backup as it is being lifted so it does not swing and collide with other rig equipment.



Pushing on the lift cylinder control valve handle (toward the center of the tong) will cause the equipment to lift. This valve handle action applies to all CE-marked tongs and is regardless of control valve bank orientation.



RIG PERSONNEL MUST STABILIZE THE TONG AS IT IS LIFTED FROM THE DRILL FLOOR



ILLUSTRATION 2.J.6: LIFT CYLINDER CONTROL - RAISE (NON CE-MARKED TONGS)

- h) Manually engage the threads of the tubing connection being made up. Ensure threads are not cross-threaded.
- i) Move the tong and backup assembly on to the tubing joint. Use the lift cylinder to ensure the assembly is at the correct height so that the backup jaws are located below the connection point, and the tong jaws are located above the connection joint.
- j) As the assembly is moved on to the joint the pipe will contact the "kicker bar" on the rear of the backup door, causing the backup door to close. Ensure backup door and tong door are fully closed against the latch posts.
- k) Firmly close the tong and backup doors. Ensure the tong doors are securely latched (tug on the tong door handle to ensure it remains latched).
- l) Ensure tubing is roughly centered within the tong and backup jaws - rig personnel are required to stabilize the tong and backup around the connection until the jaws have been clamped shut. Actuate the backup clamping valve (push it toward the centre of the tong) to clamp the backup jaws on to the tubing below the connection point. Note that the backup control is "clamp and release", meaning that once the backup jaws are clamped, the jaws remain under clamping pressure until the operator manipulates the backup control handle to release pressure (see Illustration 2.J.7 next page).

Making A Connection (Continued)

**ILLUSTRATION 2.J.7: BACKUP CONTROL - CLAMP**

- m) Begin rotation with the tong in high gear (high speed/low torque). See Section 2.H.4 to properly set the tong to high gear. Do not shift gears while the tong is rotating.



SHIFTING TONG WHILE ROTATING THE MOTOR AND CAGE PLATE MAY RESULT IN CATASTROPHIC GEAR TRAIN FAILURE

- n) Push the motor control valve toward the tong to rotate the cage plate in the make-up direction. Gently push the rotation control valve toward the centre of the tong to slowly rotate the cage plate until the tong jaws cam on to the tubing (see Illustration 2.J.8).

**ILLUSTRATION 2.J.8: MOTOR CONTROL - MAKE-UP**

Making Up A Connection (Continued)

- o) When the tong jaws cam on to the tubing push the rotation control handle all the way in to thread the connection together at high speed. As the joint becomes fully made up the increasing torque demand will stall the motor, and displayed torque will increase.
- p) Stop rotation, and set motor to low speed and shift to low gear (low speed/high torque - See Section 2.H.4 for shifting to low gear). This will enable the tong to produce adequate torque to make up the joint to specification.
- q) Push the rotation control handle all the way in to complete the connection at low speed/high torque. Observe the torque gauge - when the specified make-up torque is reached stop rotation. If your system is equipped with an automatic dump valve the system pressure will "dump" to tank when the preset torque has been reached, and all rotation will stop. Reverse the rotation control valve to release the tong jaws from the tubing (see Illustration 2.J.9).



COMPRESSION ENERGY STORED IN THE BACKUP SUPPORT SPRINGS MAY CAUSE THE TONG TO "JUMP" SLIGHTLY WHEN TONG JAWS ARE RELEASED.



ILLUSTRATION 2.J.9: USING MOTOR CONTROL TO RELEASE JAWS IN "MAKE UP" MODE

- r) When tong jaws are free release the backup jaws by pulling the backup clamp control handle away from the tong toward the operator (see Illustration 2.J.10) next page.

Making Up A Connection (Continued)

**ILLUSTRATION 2.J.10: USING BACKUP CONTROL TO RELEASE BACKUP JAWS**

- s) Unlatch and open the tong door to free the assembly from the tubing. Note that rig personnel may be required to stabilize the equipment as it completely releases from the tubing. Guide the assembly away from the string. Push the lift cylinder control valve toward the centre of the tong to lower the equipment to the drill floor.



Pulling on the lift cylinder control valve handle (toward the operator) will cause the equipment to lower. This valve handle action applies to all CE-marked tongs and is irregardless of control valve bank orientation.

**ILLUSTRATION 2.J.11: USING LIFT CYLINDER CONTROL TO LOWER ASSEMBLY (NON CE-MARKED TONGS ONLY)**

- t) Repeat steps "e" through "p" until the desired number of connections are made up.

2. Breaking Out A Connection

Your tong and backup assembly should be properly suspended, connected to a hydraulic power source, and ready to make or break connections at this point.

- a) Ensure hydraulic power supply to the tong and backup is energized. The master link on the rigid sling must be used to suspend the tong. Do not suspend the tong directly from the rigid sling. See Illustration 2.J.1.
- b) Set the backing pin for "breakout" operation. Lift up on the backing pin and rotate it to the "breakout" position, which is 2 o'clock as seen from the front of the tong. The opening in the rotary gear must be aligned with the tong door opening in order to properly set the backing pin.



ILLUSTRATION 2.J.12: SETTING BACKING PIN TO BREAK-OUT POSITION

- c) Properly configure the load cell for making up connections (see Section 2.G.3). Connect snub lines to the rear of the tong to arrest uncontrolled rotation of the assembly in the event of backup jaw slippage. The snub lines must be rated for the applied torque plus whatever safety margins stated by your own operating policies. The snub line connection points on the drill floor must be sturdy enough to absorb all applied forces.
- d) Unlatch and open the tong and backup doors (see Illustrations 2.J.3 - 2.J.5).
- e) Actuate the lift cylinder control valve to lift the assembly from the drill floor. Pull the valve toward the operator to retract the lift cylinder to lift the assembly (see illustration 2.J.6). Note that rig personnel are required to stabilize the tong and backup as it is being lifted so it does not swing and collide with other rig equipment.

	<p>Pushing on the lift cylinder control valve handle (toward the center of the tong) will cause the equipment to lift. This valve handle action applies to all CE-marked tongs and is regardless of control valve bank orientation.</p>
---	---



RIG PERSONNEL MUST STABILIZE THE TONG AS IT IS LIFTED FROM THE DRILL FLOOR

- f) As the assembly is moved on to the joint the pipe will contact the "kicker bar" on the rear of the backup door, causing the backup door to close. Ensure backup door and tong door are fully closed against the latch posts. Use the lift cylinder to ensure the assembly is at the correct height so that the backup jaws are located below the connection point, and the tong jaws are located above the connection joint.
- g) Firmly close the tong and backup doors. Ensure the tong doors are securely latched (tug on the tong door handle to ensure it remains latched).

Breaking Out A Connection (Continued)

- h) Ensure tubing is roughly centered within the tong and backup jaws - rig personnel are required to stabilize the tong and backup around the connection until the jaws have been clamped shut. Actuate the backup clamping valve (push it toward the centre of the tong - see Illustration 2.J.7) to clamp the backup jaws on to the tubing below the connection point. Note that the backup control is "clamp and release", meaning that once the backup jaws are clamped, the jaws remain under clamping pressure until the operator manipulates the backup control handle to release pressure.
- i) Breakout torque is only available in low gear. See Section 2.H.4 to properly set the tong to low gear. Do not shift gears while the tong is rotating.



SHIFTING TONG WHILE ROTATING THE MOTOR AND CAGE PLATE MAY RESULT IN CATASTROPHIC GEAR TRAIN FAILURE

Gently push the rotation control valve toward the centre of the tong to slowly rotate the cage plate until the tong jaws cam on to the tubing.



ILLUSTRATION 2.J.13: MOTOR CONTROL - BREAK OUT

- j) Push the rotation control handle all the way in to ensure full breakout torque is being delivered to the joint.
- k) When the joint releases, stop rotation and shift tong to high gear (see Section 2.H.4 to properly set the tong to high gear). Press motor control valve toward the centre of the tong to completely un-thread the connection. Do not shift gears while the tong is rotating.



SHIFTING TONG WHILE ROTATING THE MOTOR AND CAGE PLATE MAY RESULT IN CATASTROPHIC GEAR TRAIN FAILURE

Breaking Out A Connection (Continued):

- l) Once the connection has been un-threaded reverse the rotation control handle (pull toward operator) to release the tong jaws from the tubing (see Illustration 2.J.14).



ILLUSTRATION 2.J.14: USING MOTOR CONTROL TO RELEASE JAWS IN "BREAK OUT" MODE

- m) When tong jaws are free release the backup jaws by pulling the backup clamp control handle away from the tong toward the operator (see Illustration 2.J.10).
- n) Unlatch and open the tong door to free the assembly from the tubing. Note that rig personnel may be required to stabilize the equipment as it completely releases from the tubing. Guide the assembly away from the string and use the lift cylinder control to lower it to the drill floor.



RIG PERSONNEL MUST STABILIZE THE TONG AS IT IS LIFTED FROM THE DRILL FLOOR

- o) Use your rig's standard pipe handling procedures to remove and rack the freed tubing section or stand.
- p) Repeat steps "f" through "p" as many times as necessary to breakout and un-thread the desired number of connections



***This page intentionally
left blank***

McCoy Completions & Drilling recognizes that minor on-site repairs and modifications are required to maintain peak operating condition of your equipment, or to match your equipment with the operating environment. Examples of minor repairs are

- replacement of damaged hydraulic hoses and fittings.
- replacement of malfunctioning pressure gauges and valves.
- replacement of door spring stop cylinders
- replacement of fasteners

Any replaced component must be an identical component supplied by McCoy Completions & Drilling. Replaced fasteners must be Grade 8 or equivalent, or whatever fastener is specified by McCoy.

A. GENERAL MAINTENANCE SAFETY PRACTICES

The practices identified here are intended as a guideline. All personnel are responsible for performing their tasks in a manner that ensures worker, equipment, and environmental safety, and may require taking additional steps that are not identified in this section.

Equipment maintenance shall be performed only by designated qualified maintenance personnel. Wear all personal protective equipment (PPE) specified by your company's HSE policy, and follow all of your company's safety guidelines. Do not begin a maintenance task without the proper tools or materials on hand, or the proper drawings and documentation necessary.

Schedule planned maintenance with operators to avoid conflicts, unnecessary downtime, and the danger of accidental equipment activation. Notify operations when maintenance procedures are complete and equipment functionality is restored and tested.

If on-site maintenance must be performed (in other words, if equipment cannot be transported to a controlled maintenance facility) isolate the location of the maintenance to prevent unaware personnel from inadvertently exposing themselves to a hazard. Use tape, rope, or signage to clearly indicate "off-limits" area.

Replacement of large, heavy individual parts and/or heavy structural components must be performed using an approved lifting device of sufficient lifting capacity. Use care when attaching the lifting device, and safeguard area to avoid endangering personnel or equipment.

All spare parts must meet or exceed OEM specifications in order to maintain equipment integrity, especially protective equipment.



DO NOT PERFORM MAINTENANCE UNTIL TUBULAR CONNECTION EQUIPMENT HAS BEEN COMPLETELY ISOLATED FROM HYDRAULIC POWER

Your equipment uses materials that may be harmful to the environment if improperly disposed of (hydraulic fluid, grease, etc.). Dispose of all materials according to your company's proscribed environmental protection regulations.

B. CLEANING

Clean tong thoroughly cleaned with a good petroleum-based cleaning agent after each job, prior to storage. Farr® recommends that the motor and valve assembly be periodically removed, along with the top tong plate, so that guides, rollers and gears can be properly cleaned (see Section 3.H, Overhaul). Ensure that cleaning solvents and chemicals are captured to prevent environmental contamination, and dispose of all materials according to your company's proscribed environmental protection regulations.

C. PREVENTIVE MAINTENANCE PRACTICES

Regular maintenance programs are necessary, and must be established to assure safe, dependable operation of your Hydraulic Tubular Connection System and to avoid costly breakdown maintenance. The following maintenance procedures provides information required to properly maintain your equipment. Your equipment may require more, or less maintenance depending upon the frequency of use and the field conditions under which your equipment operates. These maintenance procedures are designed for equipment operating at 10°C to 35°C ambient temperature for 10 hours per day. McCoy recommends that the inspection and maintenance procedures in this section be performed as recommended in the maintenance checklists (see Appendices), or in conjunction with your maintenance foreman's experience and best estimate of when your equipment is due for this maintenance.

Manufacturers of purchased components included with your hydraulic tubular connection equipment (for example: motors, valves, etc.) may specify maintenance tasks and intervals over and above what McCoy recommends as part of their recommended procedures. Users of this equipment may choose to perform or ignore these additional tasks at their discretion.

Filtration of the hydraulic fluid must be 10 microns or better. Premature fouling of particulate filters within your prime mover or ancillary hydraulic power unit requires immediate hydraulic fluid laboratory analysis to prevent premature wear of hydraulic system due to high levels of wear metals in the fluid.

McCoy Drilling & Completions recommends tracking all maintenance activity including the lubrication schedule and replacement of hydraulic hoses. This may be as simple as keeping a paper log, or using a software-based maintenance tracking utility. A maintenance log is a valuable tool that can be used for easily retrieving maintenance history or identifying trends that require correction.

D. HYDRAULIC SYSTEM DE-PRESSURIZATION

McCoy Drilling & Completions recommends that the hydraulic system be de-pressurized prior to maintenance on any hydraulic component. Perform the following steps to ensure the dangers posed by hydraulic fluid under pressure are minimized.



ENSURE ADEQUATE CONTAINMENT IS IN PLACE TO PREVENT ENVIRONMENTAL CONTAMINATION FROM RESIDUAL HYDRAULIC FLUID

- 1) Rotate the tong to the "open throat" position. Ensure tong and backup doors (if equipped) are closed. Fully extend the lift cylinder
- 2) De-energize the power unit.
- 3) Repeatedly actuate the tong motor control valve lever IN BOTH DIRECTIONS to dissipate any residual pressure in the valve and motor.
- 4) Remove the hydraulic SUPPLY line from the equipment.
- 5) Repeatedly actuate the remaining control valve levers IN BOTH DIRECTIONS to dissipate any residual pressure in the remainder of the hydraulic control system.
- 7) Disconnect the hydraulic RETURN line from the equipment.
- 8) Disconnect remaining hoses such as case drains, or lines connected to the turns counter.



HYDRAULIC PRESSURES AS HIGH AS OPERATING PRESSURE MAY REMAIN TRAPPED IN SMALL AREAS OF THE EQUIPMENT. ENSURE ALL MAINTENANCE IS CARRIED OUT BY A QUALIFIED SERVICE TECHNICIAN, AND THAT ADEQUATE PERSONAL PROTECTIVE EQUIPMENT IS USED TO GUARD AGAINST PRESSURE INJURIES

E. LUBRICATION

Use a quality multipurpose bearing lubricant that will remain within its viscosity range at expected operating temperatures. In addition, Farr recommends the following lubrication procedure at the completion of each job prior to storage.

McCoy recommends that a liberal coating of grease be applied to the cam surface of the rotary drive gear prior to jaw installation. Also, the clutch inspection plate should periodically be removed, and a liberal coating of grease applied to the clutch, drive gears and shifting shaft.

Coat the jaw pins and rollers with a liberal amount of anti-seize compound when installing new jaw die kits

1. Cage Plate Guide Rings / Cam Followers

KT1625 Tongs (See Illustration 3.D.1)

Rotate the rotary gear out of the cage plate assembly. Apply grease to the top and bottom guide rings, and to the cage plate slots opposite the rotary gear.

Apply grease to top
guide ring & bottom
guide ring groove

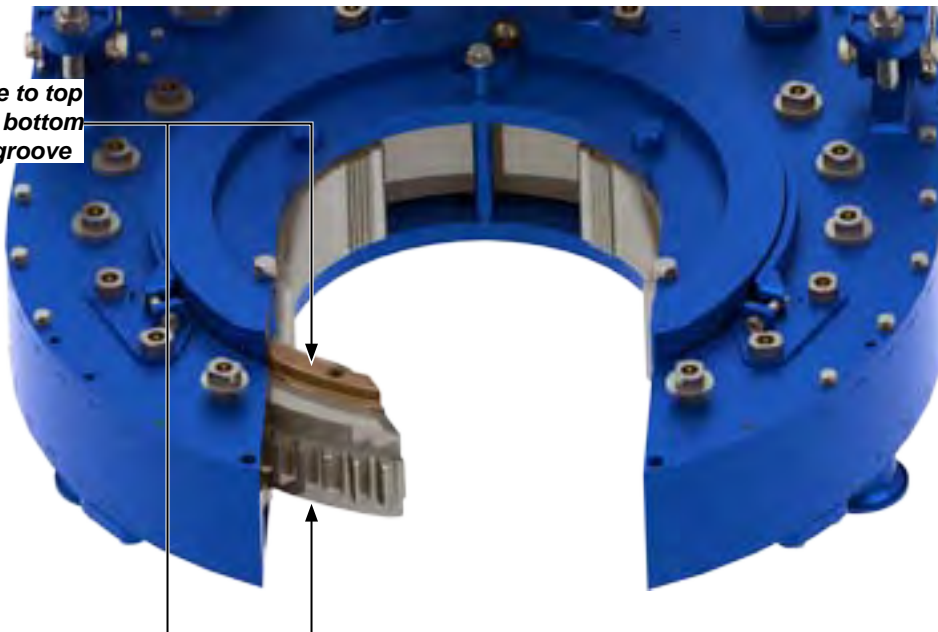

ILLUSTRATION 3.E.1: KT13625 GUIDE RING LUBRICATION

Cage Plate Guide Rings / Cam Followers Continued:

LW1625 Tongs (See Illustration 3.E.2)

Apply grease to the cam followers through the grease fittings recessed in both the top and bottom cage plates (22 locations total).

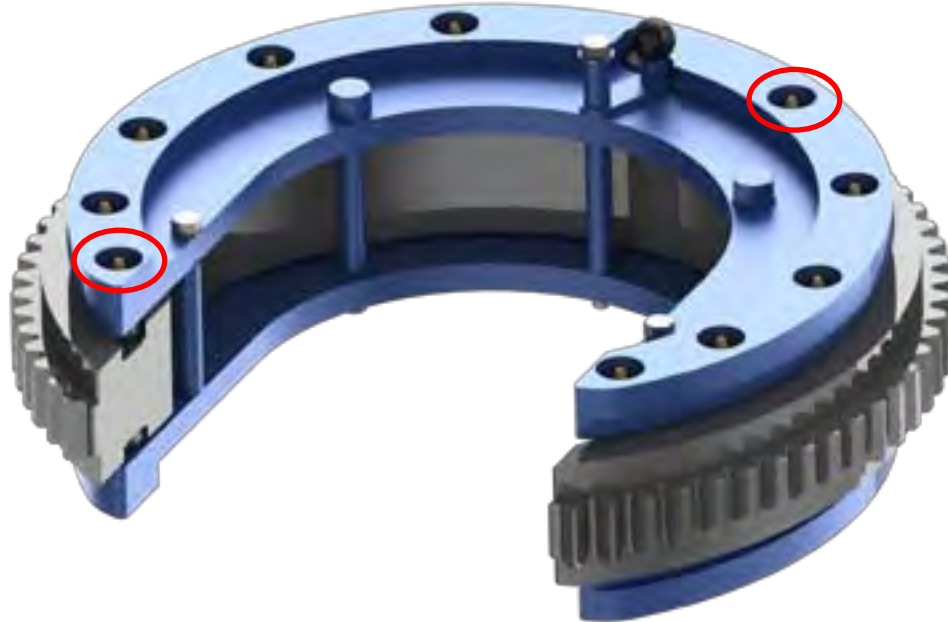

ILLUSTRATION 3.E.2: LW13625 CAM FOLLOWER LUBRICATION

2. Support Roller Bearings

Supply grease to these bearings through the grease fittings in the ends of the rotary roller shafts, located on the top of the tong (14 locations total).

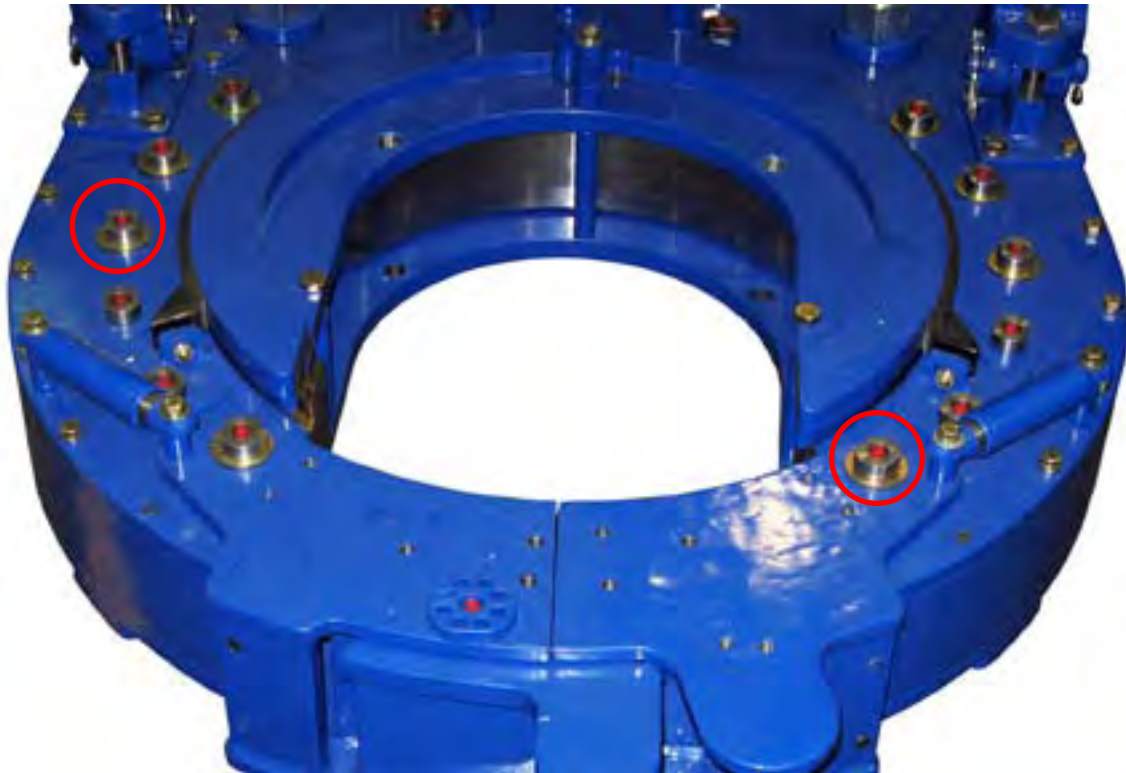

ILLUSTRATION 3.E.3: SUPPORT ROLLER BEARING LUBRICATION

3. Rotary Idler Bearings

Apply grease to these bearings through the grease fittings in the ends of the rotary idler shafts located on the left and right sides of the tong (2 locations total).

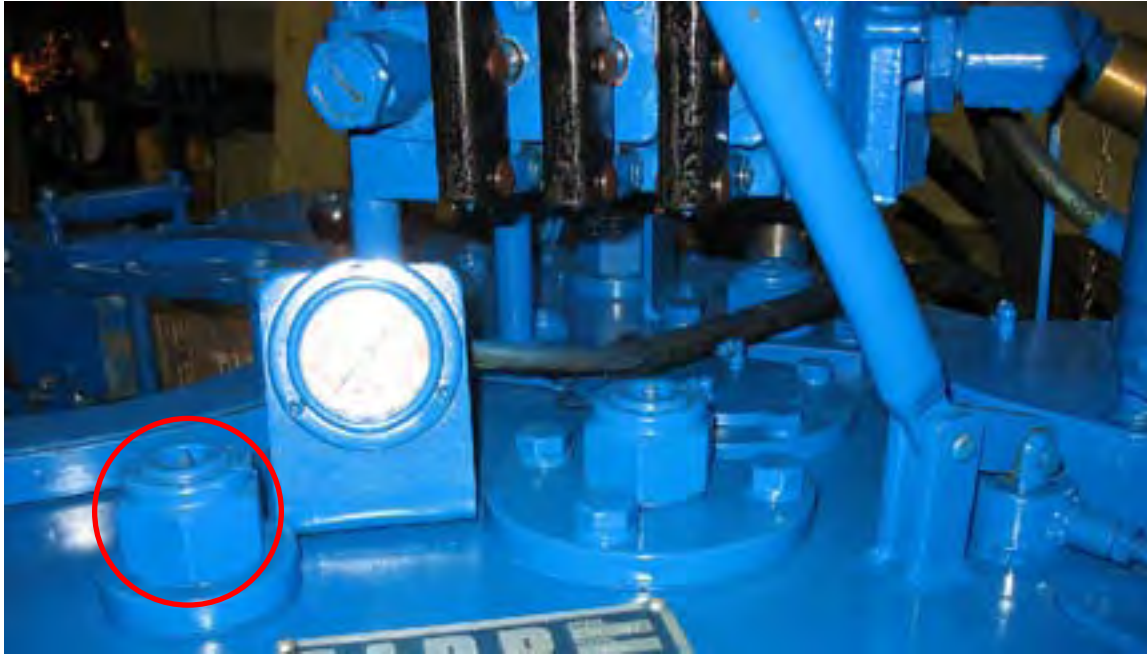

ILLUSTRATION 3.E.4: ROTARY IDLER LUBRICATION

4. Pinion Idler Bearings

Apply grease to these bearings through the grease fittings in the ends of the idler half shafts, located on the top face of the tong (2 locations total).

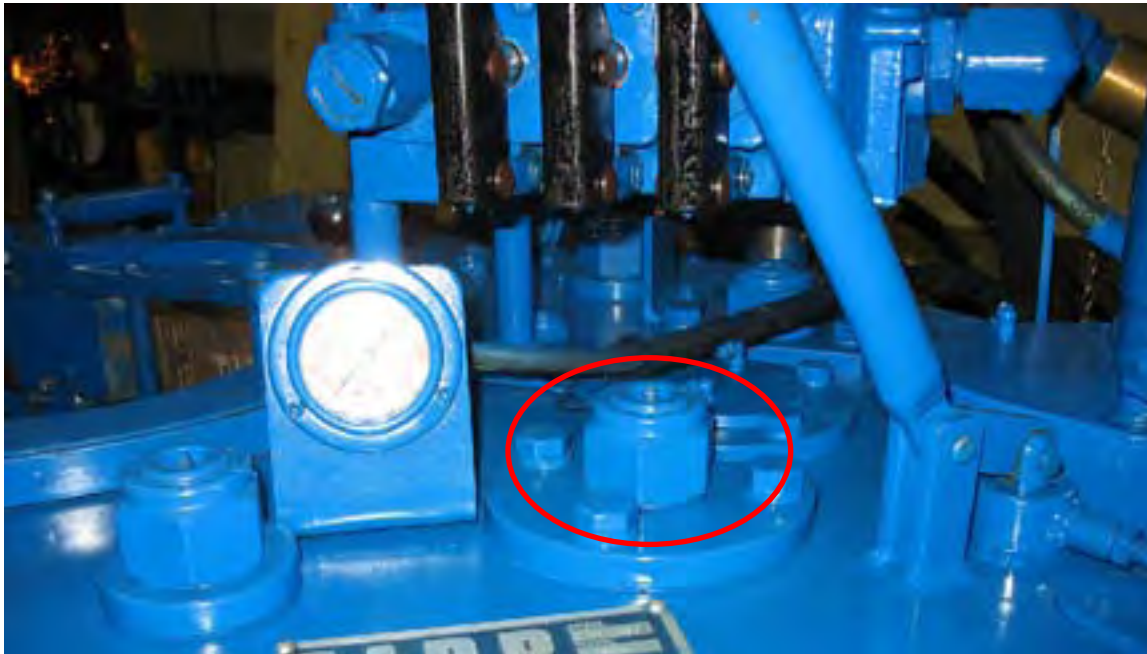

ILLUSTRATION 3.E.5: PINION IDLER LUBRICATION

5. Pinion Bearings

Apply grease to these bearings through the grease fittings in the pinion bearing caps, which are located on the top and bottom face of the tong (four locations total).



ILLUSTRATION 3.E.6: PINION LUBRICATION TOP PLATE



ILLUSTRATION 3.E.7: PINION LUBRICATION BOTTOM PLATE

6. Clutch Shaft

Apply grease to these bearings through the three grease fittings in the clutch bearing cap, which is located at the bottom face of the tong.



ILLUSTRATION 3.E.8: CLUTCH SHAFT LUBRICATION

7. Shifting Shaft

Apply grease to the shifting shaft and shifting shaft bushings, which may be accessed through the cover plate on the side of the tong.



Access shifter components through this panel

ILLUSTRATION 3.E.9: SHIFTING SHAFT LUBRICATION

8. Motor Mount Housing

Apply grease to the gears in this housing through the grease fitting on the top of the motor mount.



ILLUSTRATION 3.E.10: MOTOR MOUNT LUBRICATION

9. Door Latch Cam

Apply grease to the door latch cam through the grease fitting in the top of cam adjustment boss.



ILLUSTRATION 3.E.11: DOOR LATCH CAM LUBRICATION

10. Door Spring Cylinders

Periodically disassemble the door stop cylinders and coat the spring and cylinder with a general purpose lubricating oil.



ILLUSTRATION 3.E.12: DOOR STOP SPRING LUBRICATION



THE DOOR STOP CYLINDER SPRING MAY RETAIN ENERGY FROM BEING COMPRESSED. USE A CLAMP TO CONTAIN THE ENDS OF THE CYLINDER WHEN IT IS REMOVED, AND RELIEVE THE SPRING TENSION GRADUALLY.

11. Backup Cage Plate Cam Followers

Apply grease to the backup cam followers through the grease fitting on top of each cam adjustment follower (22 locations total).

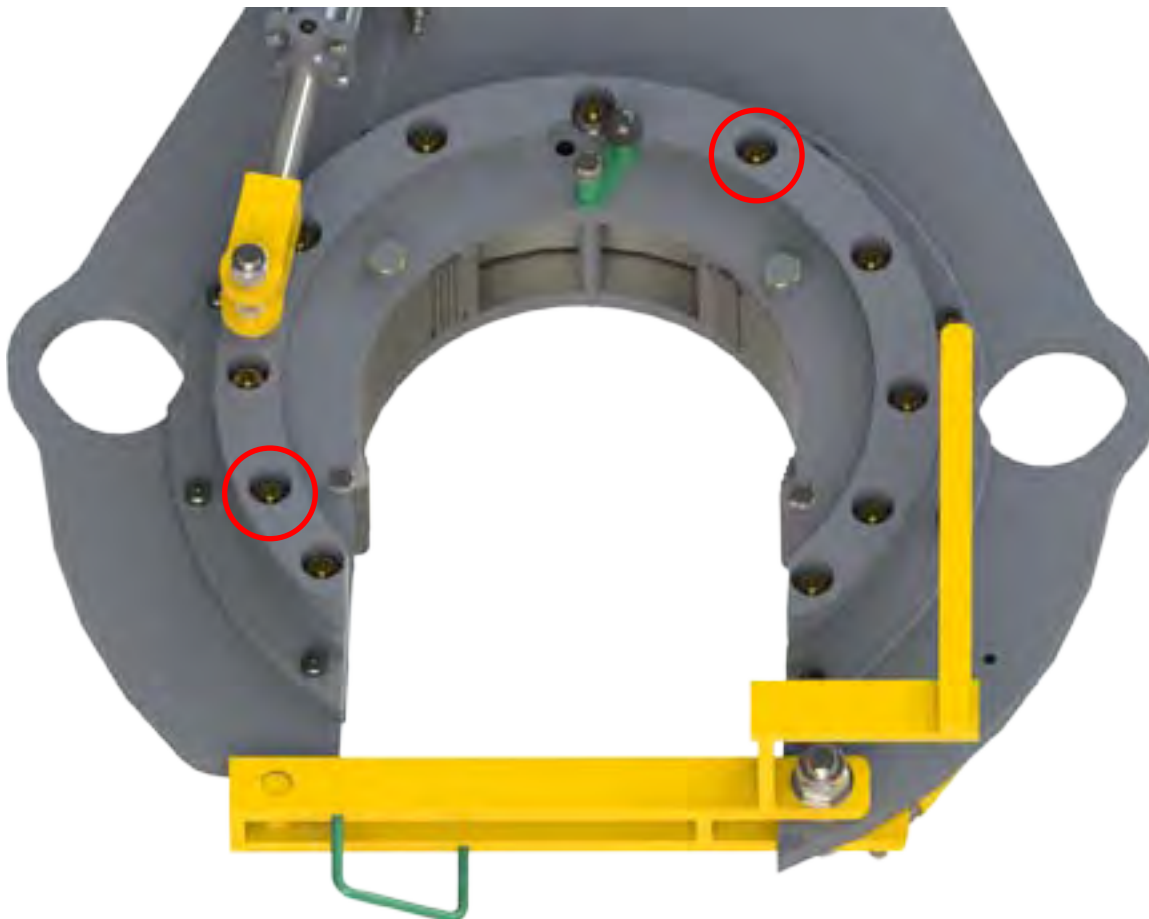

ILLUSTRATION 3.E.13: FARR® BACKUP CAM RING CAM FOLLOWER LUBRICATION

F. ADJUSTMENTS**1. Brake Band Adjustment:**

The top and bottom brake bands must be periodically adjusted to continue to provide smooth and efficient jaw cam action. If the cage plate turns with the rotary gear, the jaws will not cam properly and, therefore, will not bite on the tubing or casing. Tightening the brake band against the cage plates will increase frictional resistance, allowing jaws to cam properly and grip the casing. Adjust the brake band using the adjustment nut and bolt set as shown in the illustration below. Use caution, as over-tightening will cause excessive wear to the brake bands.



ILLUSTRATION 3.F.1: BRAKE BAND ADJUSTMENT



TOP AND BOTTOM BRAKE BANDS MUST BE ADJUSTED SIMULTANEOUSLY AND EQUALLY

2. Door Latch Adjustment

Normal operation of the tong may cause wear of the door latch, which will cause the door to develop a loose fit at the latch. A latch cam plate is located at the top face of the door. The cam plate has eight positioning holes located on a 360 degree bolt circle. The latch cam shaft extends down through the door and is secured at the top by a 3/8" hex head bolt. To make adjustments in door alignment, remove the 3/8" bolt and turn the cam with a wrench. When the door has been adequately aligned, replace the 3/8" bolt.



THE DOOR IS AN IMPORTANT PART OF THE STRUCTURAL INTEGRITY OF THE TONG. IT IS IMPERATIVE TO KEEP A SECURE FIT AT THE DOOR IN ORDER TO MAINTAIN PROPER GEAR ALIGNMENT, AND TO MINIMIZE THE POSSIBILITY OF DAMAGE TO THE GEAR TRAIN WHEN OPERATING THE TONG AT SPECIFIED TORQUE. A CLOSED DOOR ALSO ENSURES SAFETY OF OPERATING PERSONNEL.

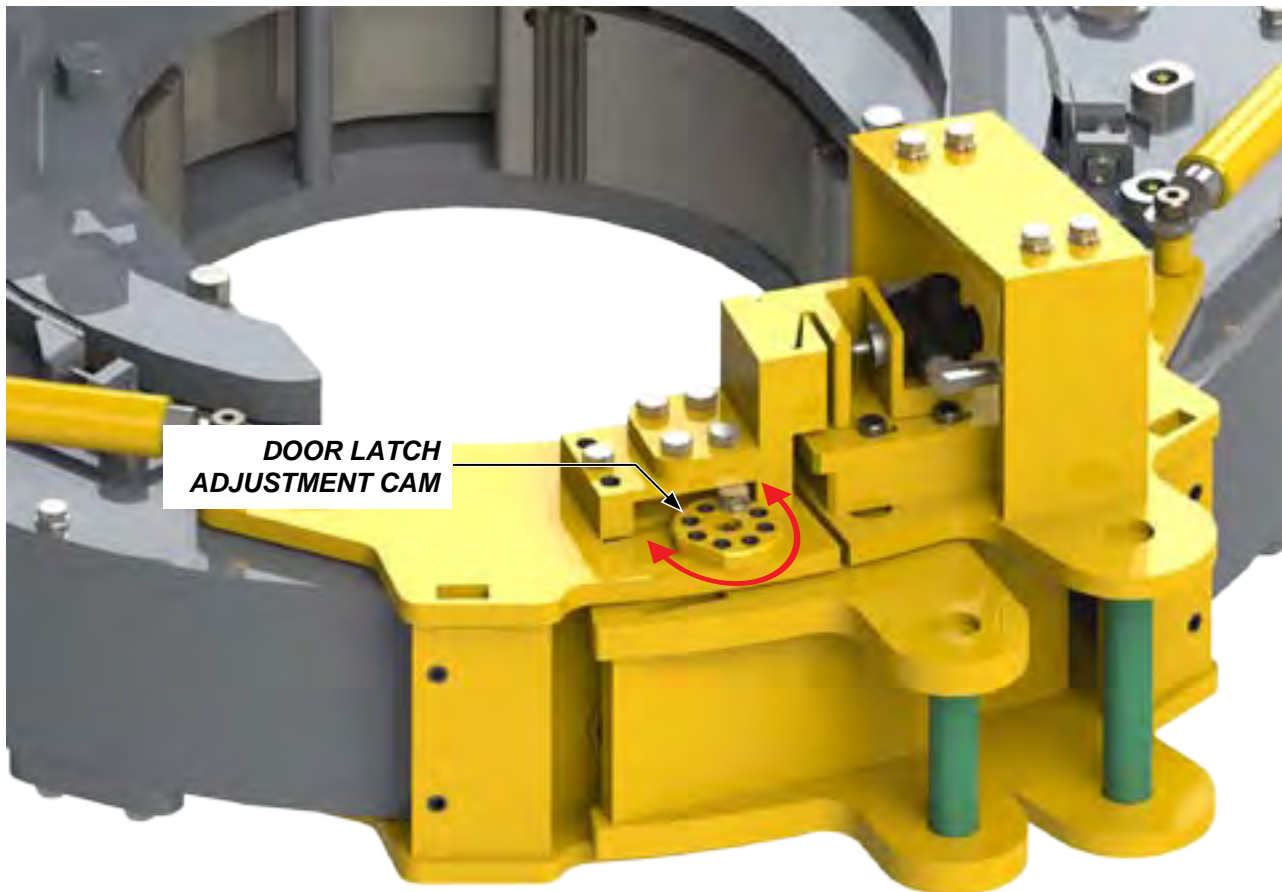

ILLUSTRATION 3.F.2: DOOR LATCH CAM ADJUSTMENT

3. Door Alignment

Each door weldment is equipped with two set screws, along with jam nuts to lock position, to align the door when it is in the closed position.

INITIAL ALIGNMENT

Ensure tong doors are closed, and inspect how one door aligns with the other at the point at which they meet. If misalignment is seen, choose one or the other door to adjust. Use a box-end wrench to loosen the lock nuts on the insides of the door weldment - the nuts may be accessed from the side of the door weldment. Use a hex key to turn the hex head set screws either clockwise or counter-clockwise to adjust the door. Note that the top and bottom of the door weldment may not need to be adjusted equally - each set screw should be adjusted independently until the doors are aligned.

FINAL ALIGNMENT

Rotate the cage plate, and stop it when the inside circumference of the door is completely covered. Perform three measurements (see illustration next page):

- 1) From the insides of the outer edge of each door weldment to the cage plate (2 measurements total).
- 2) From the exact centre point (where the two doors meet) to the cage plate.

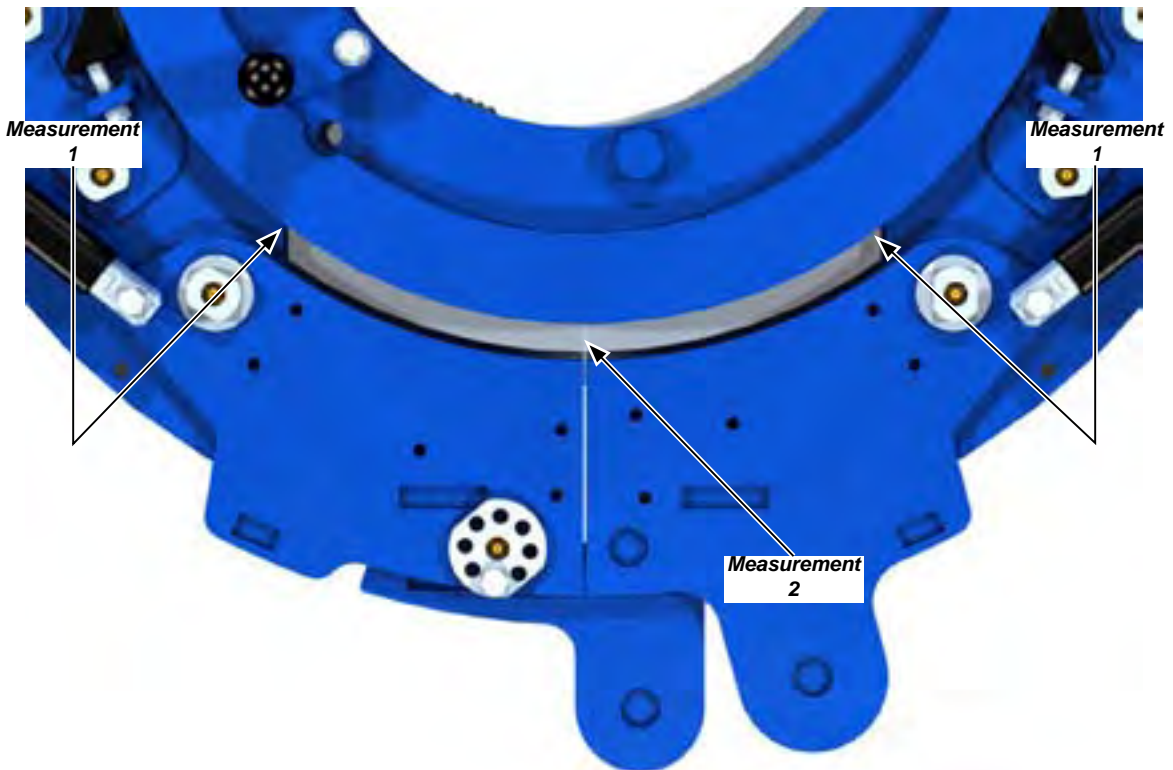

ILLUSTRATION 3.F.3: DOOR ALIGNMENT

The three measurements should be equal. If the centre measurement is less than the two outside measurements, loosen all four locking nuts on the set screws, and turn all four set screws EQUALLY clockwise, until the centre measurement is equal to the two outer measurements. If the centre measurement is more than the two outside measurements, loosen all four locking nuts on the set screws, and turn all four set screws EQUALLY counter-clockwise, until the centre measurement is equal to the two outer measurements. Ensure that the locking nuts are tightened when this procedure is complete.

4. Shifter Detent Force Adjustment:

Over time wear to the shifting shaft, wear to the detent ball, and loss of spring tension in the detent spring may result in a loose or "sloppy" fit within the top shifter bushing. The detent pressure may be increased or otherwise adjusted by loosening the 7/16" UNF locking jam nut, and turning the 7/16" UNF detent bolt. Should adequate detent action not be achieved, the shifting shaft, detent ball, or detent spring (or possibly all three) may need to be replaced (see Pp. 5.16 - 5.17).

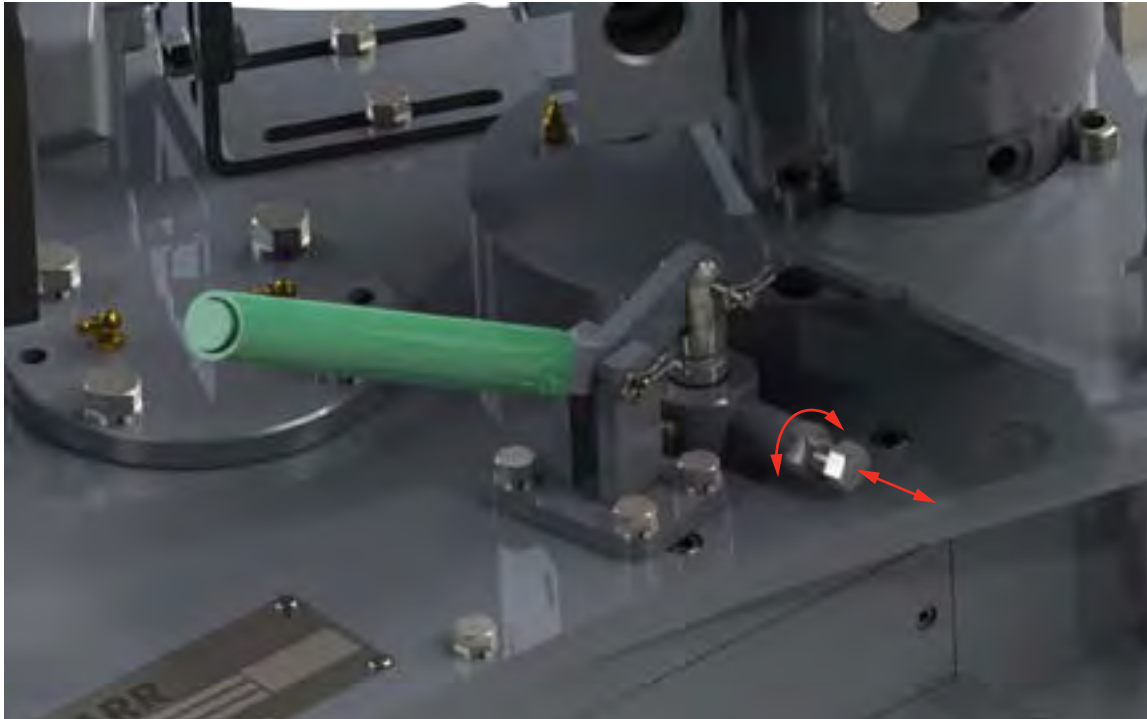

ILLUSTRATION 3.F.4: SHIFTER DETENT FORCE ADJUSTMENT

5. Safety Door Adjustment:

The safety door system is the prime protective measure separating the operator from the rotary gear, and must be in working condition when operating tong. The safety door switch is designed to interrupt hydraulic power to the motor when the tong door is opened, or even slightly ajar. This is a critical safety system, and proper adjustment is necessary to maintain the intended function.



KEEP HANDS CLEAR OF SAFETY DOOR LATCH CLAWS (PAINTED YELLOW) WHEN CLOSING DOOR.

If the rotary gear does not stop immediately and completely stop rotating when the door is opened, remove the tong from service and perform the following adjustments:

- a. Perform a preliminary assessment to ensure the safety door switch is functioning:
 - i. Connect the tong to hydraulic power in a controlled environment.
 - ii. Attempt to rotate the cage plate. Failure of the cage plate to rotate with the doors closed indicates that the safety door system has failed completely, or simply requires adjustment.
 - iii. Open the tong doors and fully depress the hydraulic switch to simulate the position of the switch when the doors are closed
 - iv. Keep hands clear of the cage plate assembly, and attempt to rotate cage plate. If the cage plate does not rotate the safety door system has failed and must be repaired before proceeding. When the cage plate begins to rotate release the safety door switch. The cage plate must immediately and completely stop rotating, indicating that the safety door system is operational but requires adjustment.

If the safety door system is confirmed operational but the cage plate does not rotate with the doors closed the adjustment plate must be moved toward the RH door assembly, enabling the safety door switch to be "made" when the doors are closed.

- b. Disconnect hydraulic power to the tong. Remove the safety door guard. Wire ties (if applicable) require removal before the fasteners securing the guard to the top plate of the door can be extracted.

Safety Door Adjustment (continued):

- c. Remove the four shoulder bolts securing the floating plate and safety door switch to the mounting plate on the LH door assembly. Perform an initial alignment of the safety door mechanism. Loosen the four hex socket head cap screws enough to lightly tap the bottom mounting plate toward the RH door assembly. Only move the bottom mounting plate in very small increments at a time (about one millimeter per adjustment step). See Illustration 3.F.5.

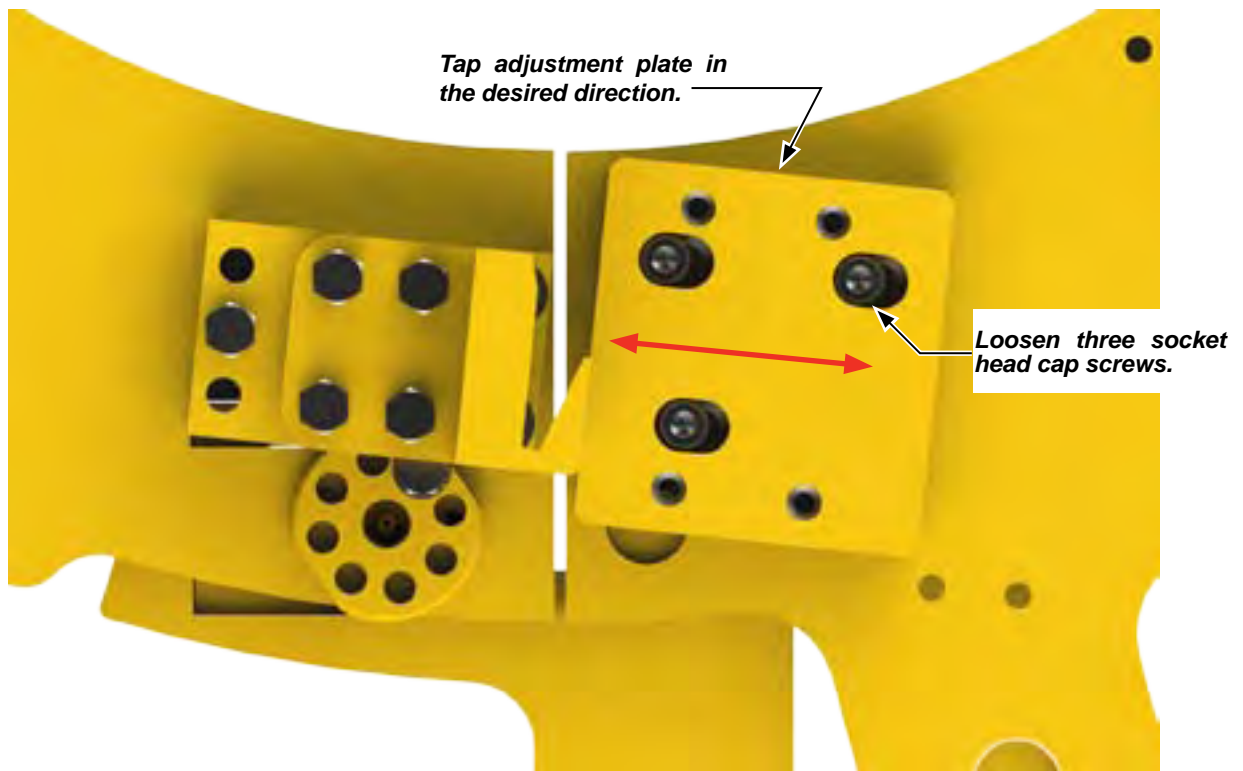

ILLUSTRATION 3.F.5: SAFETY DOOR SWITCH PLATE ADJUSTMENT

- d. Tighten the socket head cap screws to secure the adjustment plate. Use the four shoulder bolts to re-mount the floating plate and safety door switch to the mounting plate on the LH door assembly.
- e. Test the safety door system. Connect hydraulic power to the tong. Ensure the door is closed and all personnel are clear. Attempt to rotate the cage plate. If the cage plate does not rotate further adjustment of the switch is required. Repeat steps c, d, & e.
- f. When the cage plate rotates with the door closed re-test the system to ensure power to the motor is interrupted when the door is open - the cage plate should immediately and completely stop when the doors are opened.
- g. If adjustment limits have been reached before safety door function has been established further troubleshooting of the safety door system is required before the tong is placed into service. Some components may be worn past their useful lives, and replacement of those components is necessary to restore proper safety door function.

G. RECOMMENDED PERIODIC CHECKS**1. Door Stop Spring**

The spring inside the actuator cylinder must be of sufficient strength to enable the door latch mechanism to snap closed properly. Door stop spring fatigue will result in sluggish latch operation. Replace the latch spring inside the cylinder when this occurs.

2. Shifting Shaft

The shifting yoke is secured to the shifting shaft by one hex jam nut and one locknut on the bottom of the yoke. Check these nuts after each job. Do this by removing the clutch inspection plate and ensuring a snug fit prior to lubrication.

3. Backing Pin

Perform a visual inspection of the backing pin after each job. Replace the pin if stress cracks or excessive wear is found, or if the pin appears bent.

4. Torque Gauge Assembly

Periodic calibration of the torque gauge is recommended to assure accurate torque readings. When having the torque gauge serviced and calibrated, it is critical to note the arm length of the tong, as indicated on page 1.3.

H. OVERHAUL PROCEDURES

The tong may be overhauled following the disassembly instructions in the following procedure. Access to the gear train is possible by removing the top plate of the tong.



ALL MAINTENANCE AND OVERHAUL SHOULD BE PERFORMED FROM THE TOP. THE BOTTOM PLATE OF THE TONG IS TYPICALLY WELDED TO THE SIDE BODY AND CANNOT BE REMOVED.



REPLACEMENT FASTENERS (BOLTS, NUTS, CAP SCREWS, MACHINE SCREWS, ETC.) USED DURING MAINTENANCE OR OVERHAUL MUST BE GRADE 8 OR EQUIVALENT.

FASTENERS USED FOR MAINTENANCE OR OVERHAUL OF LOAD-BEARING COMPONENTS (CHAIN SLINGS, RIGID SLINGS, LEGS) MUST BE TIGHTENED TO THE PROPER TORQUE.

REMOVAL OF BACKUP

1. Construct a support that will, when the tong and backup are lowered, support the backup assembly enough to remove the weight from the front leg and rear backup support springs.
2. Lift the tong and backup and lower onto structure constructed in step 1.
3. Free the front leg springs by removing the 1/2" x 4" bolts and bottom spring caps from the bottoms of the legs. Disconnect the rear backup support springs from the eye hooks on the bottom of the tong.
4. Lift the tong and front and rear legs up and away from the backup. Use caution not to lose the leg springs and top spring caps, which will come loose when the tong is lifted.

REMOVAL OF LEG ASSEMBLIES

5. Set the tong and leg assembly onto a flat surface. Ensure that the majority of the weight remains supported by the rigid sling and the crane, and that there is enough clearance to remove the legs when they are freed.
6. Support the rear leg weldment (weight = 208 lb/95 kg) before disconnecting from the bottom tong plate. Remove the four 1-1/4" x 8" heavy hex bolts securing the rear leg weldment. Use a crane and a temporary lifting sling to remove the rear leg weldment to a secure spot away from the disassembly location.
7. Remove the 7/16" x 3" bolts from the front leg mount weldments to remove the front leg weldments.
8. Set the tong onto a sturdy, flat work surface that provide adequate support, but still allows access to the bottom cage plate assembly. A pair of sturdy metal horses work well in this application.

REMOVAL OF TOP PLATE

9. Disconnect the hydraulic connections from the motor. Undo the restraints securing the inlet and outlet lines from their supports, and use a crane and temporary lifting sling to hoist the hydraulic valve section away from the tong. Remove the inlet and outlet support pieces.
10. Support the rigid sling with a crane. Remove the two hitch pins from each rigid sling pin, and remove the rid sling pins. The rigid sling may now be lifted away from the tong and stored in a secure location. Remove both rigid sling hanger bracket weldments.



The heads of the fasteners securing the rigid sling hanger brackets are drilled, and are constrained to the brackets using wire ties. Wire ties must be removed before extracting the fasteners and removing the rigid sling hanger bracket.

11. Remove the tong door stop cylinders. The door stop cylinder springs may retain energy from being compressed. Use a clamp to contain the ends of the cylinders when they are removed, and relieve the spring tension gradually.



THE DOOR STOP CYLINDER SPRINGS MAY RETAIN ENERGY FROM BEING COMPRESSED. USE A CLAMP TO CONTAIN THE ENDS OF THE CYLINDERS WHEN THEY ARE REMOVED, AND RELIEVE THE SPRING TENSION GRADUALLY.

12. Remove each door assembly by removing the door roller shafts. Support each door assembly as the roller shaft is removed. Remove the nut from the bottom of the roller shaft, and use a soft alloy material (e.g. brass rod, etc.) to lightly tap the shaft up through the support roller assembly until it comes free at the top. Use caution that the threads on the ends of the support roller shafts are not damaged.

NOTE: The safety door switch components may remain in place on the door assemblies.

13. Remove the two socket head cap screws securing the torque gauge mount, and lift the gauge mount out of place.
14. Remove the remaining two socket head cap screws securing the motor, and lift the motor off the motor mount. Inspect the motor gear, located at the bottom of the motor shaft, for gear clashing or tooth damage. Also, ensure that the motor gear is securely attached to the motor shaft.

Removal of Top Plate (Continued):

15. Remove the motor mount by removing the four socket head cap screws. The motor mount can be lifted out of place. Take care not to lose the two position dowels - one, or both, may come off with the mount.
16. Remove the snap ring that secures the top clutch gear. Remove the top clutch gear and top clutch bushing. Remove the #10 x 3/4" socket head cap screws securing the bearing retainer to the top plate, and remove the bearing retainer.
17. Remove the clevis pin connecting the shifting shaft handle to the shifting shaft. Back off the shifter position detent spring and ball assembly as much as possible without removing the detent assembly.
18. Remove the access panel on the body side adjacent to shifter assembly. Remove the 5/8" fine thread nut, and 5/8" fine thread jam nut from the shifting shaft to loosen the shifting fork. The shifting shaft may now be carefully rotated and pulled out of the top shifter bushing.
19. Loosen the top brake band (See page 3.3) by backing off the brake band adjustment bolts until the nut is flush with the end of the bolt.
20. Remove the backing pin assembly, but leave the rear cage plate bolt in place.



THE CAGE PLATE BOLTS ARE THE ONLY ITEMS FASTENING THE BOTTOM CAGE PLATE TO THE TONG. SUPPORT THE BOTTOM CAGE PLATE FROM BELOW PRIOR TO REMOVING CAGE PLATE BOLTS IN ORDER TO PREVENT DAMAGE TO THE BOTTOM CAGE PLATE OR PERSONAL INJURY TO THE MECHANIC

21. Remove the jaw pivot bolts and the jaw assemblies.
22. Remove the two front cage plate bolts, and the rear cage plate bolt, and the cage plate spacers. The cage plates may now be removed - use caution not to damage the bottom cage plate support ring or cage plate cam followers.
23. Pull the top bearing cap and spacer for the pinion drive gear by removing the four 1/2" bolts which secure the bearing cap. Thread two of the removed bolts into the extra holes on top of the bearing cap, and use them as lifting lugs to lift the bearing cap out of place.



IF THE BEARING REMAINS ATTACHED TO THE GEAR SHAFT AFTER THE BEARING CAP IS PULLED, MCCOY DRILLING & COMPLETIONS SERVICE PERSONNEL RECOMMENDS LEAVING IT IN PLACE UNTIL THE TOP TONG PLATE IS REMOVED.

24. Remove the 1-1/2" nuts and pads for the rotary idler gears, and the 1-1/2" nuts, 5/8" bolts, and half-moon pads from the pinion idler gears.
25. Remove the bottom roller shaft nuts.
26. Carefully remove the remaining twelve support roller shafts. A soft alloy material (e.g. brass rod, etc.) may be required to lightly tap the shafts up through the support roller assembly until they come free at the top. Use caution not to misplace the brake band lug weldments or the two hydraulic valve mounting posts that will come free with this step.
27. Remove the hex head bolts around the perimeter of the tong which secure the top plate to the gear case housing.
28. Remove the countersunk socket head screws around the perimeter of the tong.
29. With all the above steps taken, the top tong plate can be lifted off providing access to the inside of the gear case.

I. ASSEMBLY PROCEDURES

Assembly of Farr Hydraulic Power Tongs is simple, and can be accomplished without the use of special tools. The instructions on this page are presented as a guide only, and are similar to the assembly sequence our technician would use while assembling the tong in our plant.

NOTE ON INSTALLATION PRACTICES: Ensure all bearings are liberally greased before installing over a shaft or into gears or bearing caps. When inserting a shaft through a support roller assembly ensure shaft is greased. Also ensure all metal-to-metal contact in the gear train is adequately greased. **When graphics are not used in the assembly process, please refer to the relevant exploded diagrams in Section 5.**



ALL FASTENERS USED DURING REASSEMBLY OF LOAD-BEARING COMPONENTS (CHAIN SLINGS, RIGID SLINGS, BACKUP LEGS) MUST BE TIGHTENED TO THE CORRECT TORQUE. THREADED FASTENERS USED IN LOAD-BEARING DEVICES MUST BE SECURED WITH RED LOCTITE™.

TIGHTENING TORQUE GUIDE			
SAE GRADE 8 - FINE THREAD			
SIZE	CLAMP LOAD	PLAIN	PLATED
1/4 - 28 (.250)	3,263	14 ft. lbs.	10 ft. lbs.
5/16- 24 (.3125)	5,113	27 ft. lbs.	20 ft. lbs.
3/8 - 24 (.375)	7,875	49 ft. lbs.	37 ft. lbs.
7/16 - 20 (.4375)	10,650	78 ft. lbs.	58 ft. lbs.
1/2 - 20 (.500)	14,400	120 ft. lbs.	90 ft. lbs.
9/16 - 18 (.5625)	18,300	172 ft. lbs.	129 ft. lbs.
5/8" - 18 (.625)	23,025	240 ft. lbs.	180 ft. lbs.
3/4 - 16 (.750)	33,600	420 ft. lbs.	315 ft. lbs.
7/8" - 14 (.875)	45,825	668 ft. lbs.	501 ft. lbs.
1 - 12 (1.000)	59,700	995 ft. lbs.	746 ft. lbs.
1 - 14 (1.000)	61,125	1019 ft. lbs.	764 ft. lbs.
1 1/8 - 12 (1.125)	77,025	1444 ft. lbs.	1083 ft. lbs.
1 1/4 - 12 (1.125)	96,600	2012 ft. lbs.	1509 ft. lbs.
1 3/8 - 12 (1.375)	118,350	2712 ft. lbs.	2034 ft. lbs.
1 1/2 - 12 (1.500)	142,275	3557 ft. lbs.	2668 ft. lbs.
SAE GRADE 8 - COARSE THREAD			
SIZE	CLAMP LOAD	PLAIN	PLATED
1/4 - 20 (.250)	2,850	12 ft. lbs.	9 ft. lbs.
5/16- 18 (.3125)	4,725	25 ft. lbs.	18 ft. lbs.
3/8 - 16 (.375)	6,975	44 ft. lbs.	33 ft. lbs.
7/16 - 14 (.4375)	9,600	70 ft. lbs.	52 ft. lbs.
1/2 - 13 (.500)	12,750	106 ft. lbs.	80 ft. lbs.
9/16 - 12 (.5625)	16,350	153 ft. lbs.	115 ft. lbs.
5/8" - 11 (.625)	20,325	212 ft. lbs.	159 ft. lbs.
3/4 - 10 (.750)	30,075	376 ft. lbs.	282 ft. lbs.
7/8" - 9 (.875)	41,550	606 ft. lbs.	454 ft. lbs.
1 - 8 (1.000)	54,525	909 ft. lbs.	682 ft. lbs.
1 1/8 - 7 (1.125)	68,700	1288 ft. lbs.	966 ft. lbs.
1 1/4 - 7 (1.125)	87,225	1817 ft. lbs.	1363 ft. lbs.
1 3/8 - 6 (1.375)	103,950	2382 ft. lbs.	1787 ft. lbs.
1 1/2 - 6 (1.500)	126,450	3161 ft. lbs.	2371 ft. lbs.



REPLACEMENT FASTENER (BOLTS, NUTS, CAP SCREWS, MACHINE SCREWS, ETC.) USED DURING MAINTENANCE OR OVERHAUL MUST BE GRADE 8 OR EQUIVALENT UNLESS OTHERWISE SPECIFIED.

Assembly Procedure:

APPLY A THIN LAYER OF GREASE TO THE SURFACE OF EACH MOVING PART DURING ASSEMBLY TO AID IN THE ASSEMBLY PROCESS.

1. Position the tong body gear case on a suitable stationary support, ensuring that the bottom body plate remains accessible. A set of sturdy metal horses works well in this application.
2. Press support roller bearings into the support roller cups and secure with retaining rings (28 total).

KT-13625 Tongs

Press roller bearing (PN 02-0014) into a support roller cup (997-D21-135) and secure with an inside retaining ring (02-0013). Repeat for all remaining roller cup assemblies.

LW-13625 Tong

Press ball bearing (PN 02-0101) into a support roller cup (997-D21-135) and secure with an inside retaining ring (02-0013). Repeat for all remaining roller cup assemblies.

3. Use the roller cup assemblies to assemble five support roller assemblies as shown on Pp. 5.4 - 5.5, but at this time use only items B, D, E, F, G, & H (i.e. all the support roller components that reside between the top and bottom plates of the tong, plus the support roller shaft).
4. Install five support roller assemblies plus shafts along one side of the body case. Insert shafts through the bottom plate, but do not install the bottom nylock nuts or, where used, the narrow flat washers.
5. Install rotary gear (PN 997-D1-B), making sure the backing pin slots are on the side facing up. Ensure one side is supported by the support rollers installed in Step 3, and have the opening in the rotary gear oriented as shown in the following illustration.



ILLUSTRATION 3.1.1: TONG ASSEMBLY - ROTARY GEAR INSTALLATION

6. Install support roller assemblies in the locations exposed by the opening in the rotary gear. Continue to rotate the rotary gear, installing support roller assemblies in the rotary gear opening as it is rotated. Finish with the rotary gear aligned with the opening in the bottom plate. Do not install the two door pivot support roller assemblies at this time.
7. Press pinion bearing (PN 1234-08-01B) into bottom pinion bearing cap, and install bearing cap into bottom plate of tong using four 1/2" UNC x 1-1/4" hex bolts and 1/2" lock washers.
8. Press lower clutch bearing (PN 02-0014) into bottom clutch bearing cap, and install bearing cap into bottom plate of tong using four 3/8" UNC x 1-1/4" hex bolts and 3/8" lock washers.
9. Install a retainer clip (PN 02-0009) into both rotary idler gears. Press an idler bearing (PN 02-0075) into each gear and secure with a second retainer clip.
10. Lightly grease the larger circumference of the two rotary idler shafts and slide them through the bearing and gears assemblies, centering the gear on the shaft.
11. Slide two bearing seals (PN 02-0010) over each end of the idler shafts and press against the retainer clips.

Assembly Procedure Continued:

12. Slide a bearing spacer (PN 997-D20-121) over each end of the rotary idler shafts.
13. Place each rotary idler assembly through the bottom plate, ensuring the ends of the shafts with the threaded hole for the grease fitting are pointed upward.
14. Place an idler pad (PN 997-D20-125) over the bottom side of each rotary idler shaft, and secure each with a 1-1/2" UNF nylock nut.
15. Place low pinion gear shoulder side down over the lower bearing and bearing cap, centering as best as able.
16. Install pinion gear shaft into the spline of the bottom pinion gear and the lower pinion bearing.
17. Slide 2 needle bearings (02-1404) over each end of the clutch shaft, and press up against centre gear. Slide low clutch gear over the bottom end of the clutch shaft, onto the two needle bearings. Slide bottom clutch spacer (pn 997-99) over lower end of shaft, and place lower end of clutch shaft into the lower clutch bearing that has been pre-mounted in the lower body plate.
18. Install shifting collar which will slip over clutch shaft and mesh with low or high clutch gear.
19. Install the lower shifting bushing (PN 101-0003) in the bottom body plate using four 3/8" UNC x 1" hex bolts and 3/8" lock washers.
20. Slide the shifting fork (PN 997-HT-72) over the end of the shifting shaft (PN 997-B1-71), and secure fork to shaft with a 5/8" UNF hex nut. Lock the hex nut to the shifting fork with a 7/8" UNF hex jam nut. Mesh the shifting fork with the shifting collar on the clutch shaft.
21. Install a retainer clip (PN 02-0009) into both pinion idler gears. Press an idler bearing (PN 02-0075) into each gear, and secure with a second retainer clip.
22. Slide each pinion idler half-shaft through pinion gear assemblies. Slide a bearing seal (PN 02-0010) over the ends of each half-shaft, and secure with a shaft retainer clip (PN 02-0008).
23. Place pinion idler assemblies, less the idler pads and top fasteners, on top of the lower pinion gear and place them as best as possible - their position may have to be adjusted slightly as the top plate is attached (see Illustration 3.1.2).

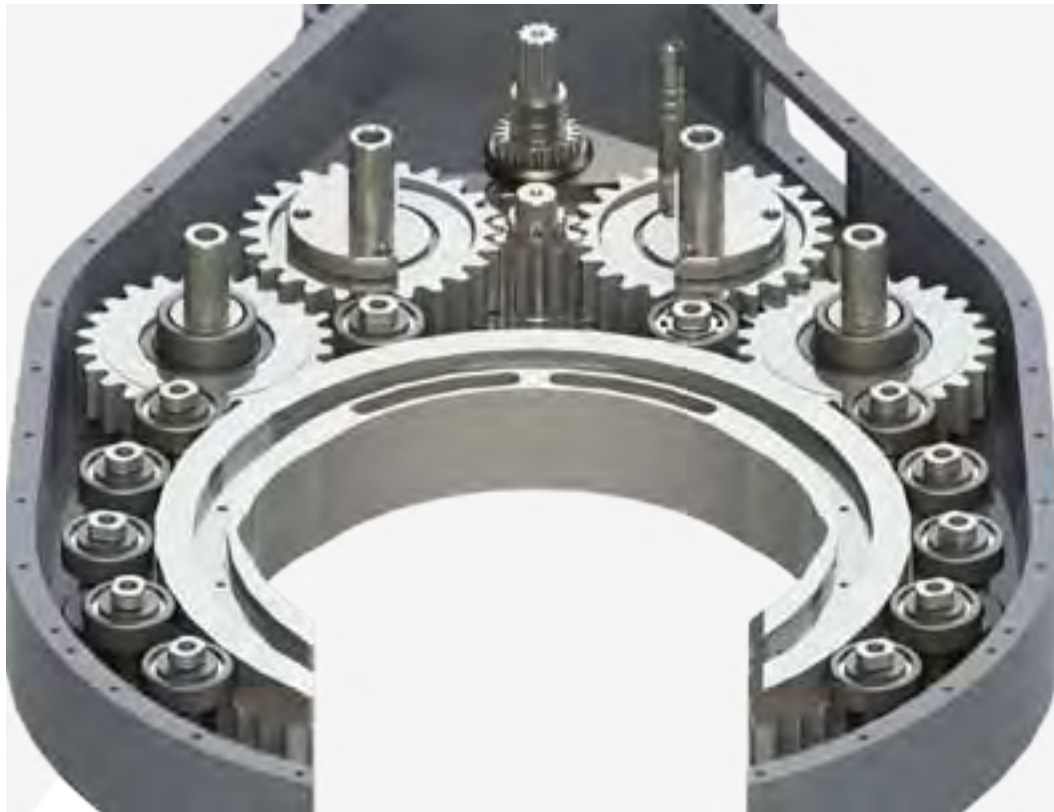

ILLUSTRATION 3.1.2: TONG ASSEMBLY - GEAR ASSEMBLY POSITIONING

24. Install high pinion gear (shoulder side up).
25. Install high clutch gear, followed by the top clutch bearing spacer (PN 101-3599).

Assembly Procedure Continued:

26. Carefully remove all support roller shafts, using caution not to shift the position of the installed support roller assemblies or to damage the threads on the end of the shafts.
27. Locate the three un-threaded holes in the side body of the tong, one in the rear centre and one just to either side of the front opening. If old dowel pins are in place, remove them before installation of the top plate. If the dowel pins are in any way damaged or deformed McCoy recommends replacing them with new 3/8" x 1-1/2" hardened dowel pins. If necessary clean the dowel pin holes, and do not insert dowel pins until after the top plate has been installed.
28. Use a temporary lifting sling and crane to maneuver the top plate (PN 101-0025) into position, and place on to the side body. Insert the three positioning dowel pins (PN 09-0092) through the top plate into their respective holes in the side body. Use a hammer to tap the dowel pins until they are flush with the top plate. Secure the top plate with eighteen 3/8" UNC x 1-1/2" hex bolts and 3/8" lock washers, and two 3/8" UNC x 1" hex socket head cap screws as shown in illustration 3.H.3. Do not install fasteners at the rigid sling hanger locations, indicated by the red circles, or the door cylinder mounting lug locations indicated by the green circles.

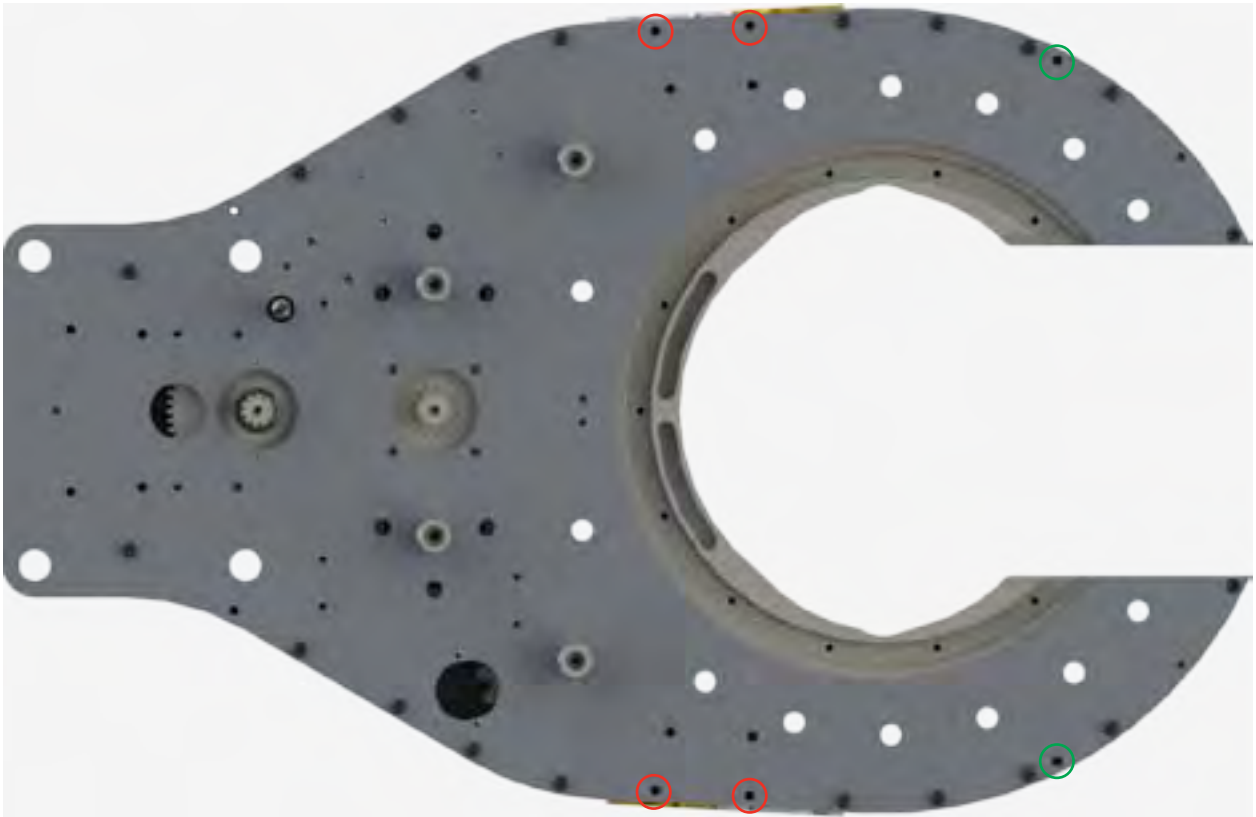

ILLUSTRATION 3.I.3: TONG ASSEMBLY - TOP PLATE FASTENERS

29. Install half-moon idler pads (9PN 997-D17-108) over the end of each pinion idler shaft, and secure each with three 5/8" UNC x 1-3/4" hex bolts and 5/8" lock washers, followed by a 1-1/2" UNF nylock nut.
30. Slide the remaining rotary idler pads (PN 997-D20-125) over the end of the two rotary idler shafts and secure each with 1-1/2" UNF nylock nuts.
31. Press the remaining pinion bearing (PN 1234-08-01B) into the top pinion bearing cap and install over the top of the pinion gear shaft - secure with four 1/2" UNC x 1-1/4" hex bolts and 1/2" lock washers.
32. Install top clutch bearing retainer (PN 997-HT-59) into top plate and secure with two 10-24 x 3/4" hex socket head cap screws. Insert top clutch bearing (PN 02-1403) over the clutch shaft into the bearing retainer, followed by the clutch bearing bushing (PN 997-HT-60).
33. Install clutch drive gear (PN 997-HT-61) on to the clutch shaft and secure with the retaining snap ring (PN 1234-00-04).

Assembly Procedure Continued:

34. Re-install support roller shafts:

- a. Slide a 7/8" narrow flat washer on to two shorter support roller shafts (PN 101-1266) and re-install in the locations circled in green in Illustration 3.1.4. Slide a 7/8" narrow flat washer over the four longer support roller shafts (PN 101-1268), and install where the support rollers are coincidental with the front leg weldments as shown circled in red in Illustration 3.1.4. Secure the bottom of the two shorter support roller shafts with 3/4" narrow flat washers and 3/4" UNF thin nylock nuts.



ILLUSTRATION 3.1.4: TONG ASSEMBLY - SUPPORT ROLLER INSTALLATION 01

Assembly Procedure Continued:

34 Re-install support roller shafts cont'd:

- b) Two rear hydraulic valve mount weldments (PN 101-0011) are coincidental with the two rear support roller shafts as shown in illustration 3.1.5. ASSEMBLY NOTE: Do not use 7/8" narrow flat washers on the tops of the shafts where they are coincidental with the brake band lug weldments. Secure the bottoms of the shafts with 7/8" narrow flat washers and 3/4" UNF thin narrow nylock nuts.



ILLUSTRATION 3.1.5: TONG ASSEMBLY - SUPPORT ROLLER INSTALLATION 02

34. Re-install support roller shafts cont'd:

- c) Ensure the two top and two bottom brake band lug weldments (top left/bottom right = PN 101-0007, top right/bottom left = PN 101-0008) are installed with the two front support roller shafts on each side as shown in Illustration 3.1.6 on the following page. Note that no flat washers are used where the shafts are coincidental with the brake band lug weldments. Secure the bottom of the four shafts with 3/4" UNF thin nylock nuts.

Assembly Procedure Continued:

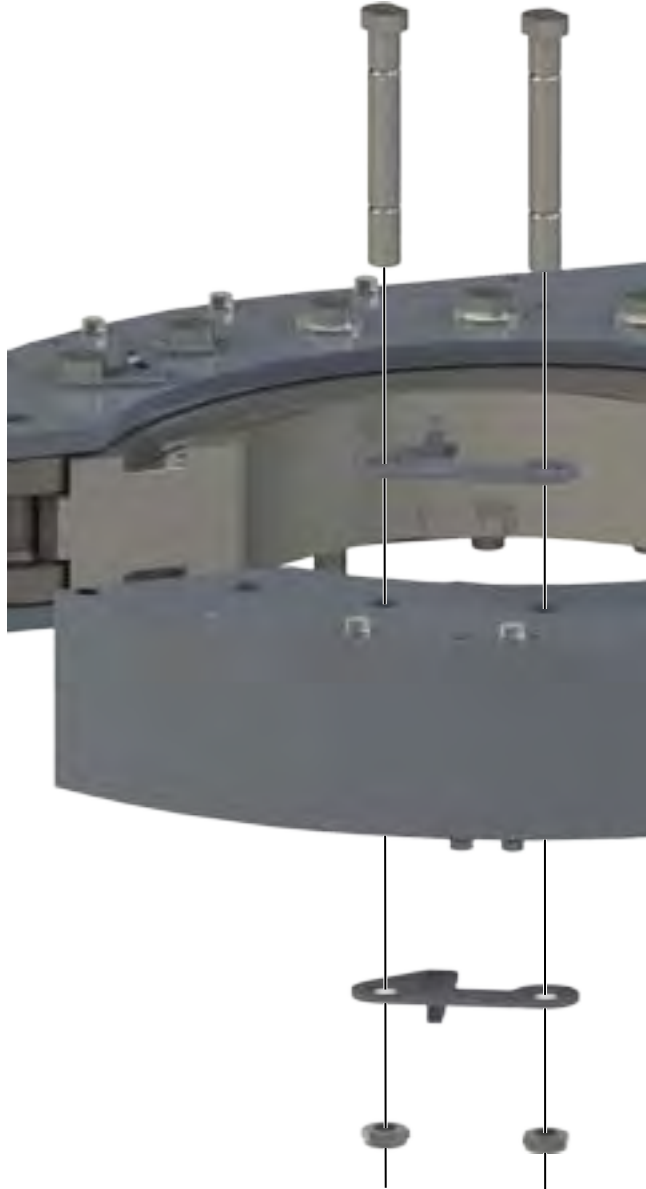
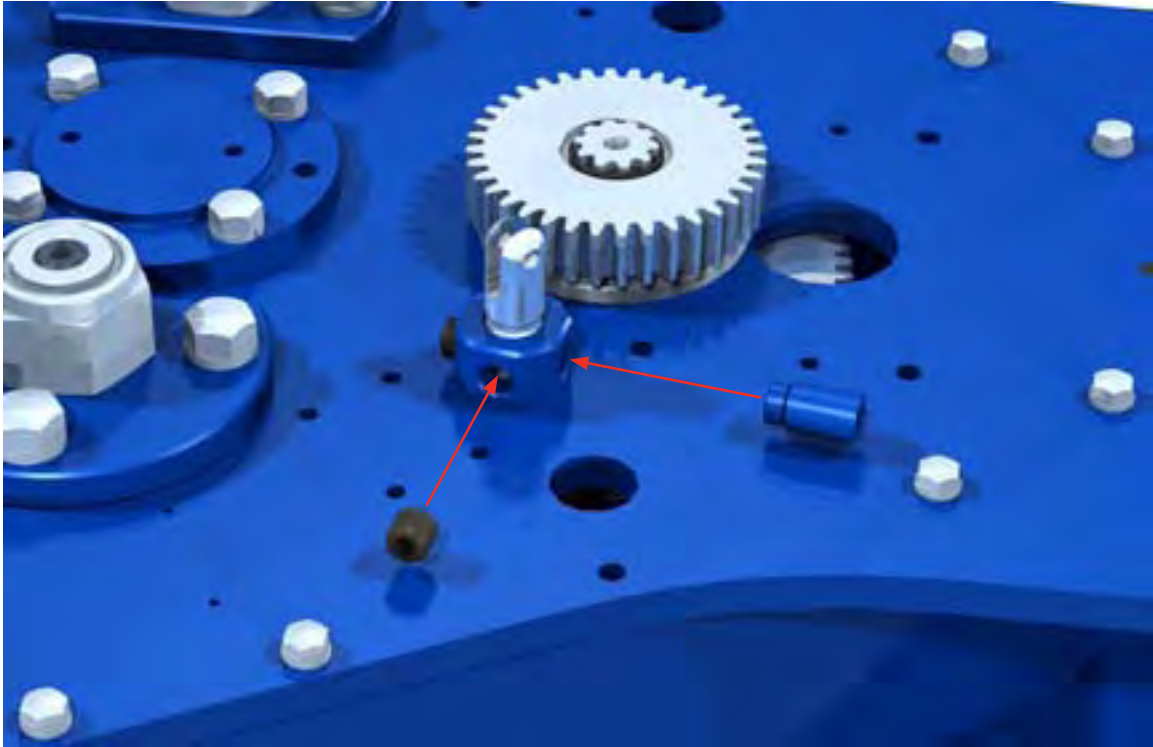

ILLUSTRATION 3.1.6: TONG ASSEMBLY - SUPPORT ROLLER INSTALLATION 03

35. Coat the threads of the top shifter bushing (PN 101-0020) with red Loctite™. Thread the top shifter bushing over the shifting shaft into the top plate until snug. Thread the detent tube (PN 101-0019) into the top shifter bushing as shown in illustration 3.1.7.
36. Thread three 5/8" UNC x 5/8" hex socket set screws into the remaining three ports in the bushing as shown in illustration 3.1.7. These set screws are intended to be used as contamination barriers only. Do not bottom out the set screws on the shifting shaft, or the shaft will not move.

Assembly Procedure Continued:**ILLUSTRATION 3.I.7: TONG ASSEMBLY - TOP SHIFTER BUSHING INSTALLATION**

37. Insert the shifter detent ball (PN 02-0018) into the detent tube, followed by the detent spring (PN 02-0040). Thread a 7/16" UNF hex jam nut onto a 7/16" UNF x 1-1/4" hex nut, then thread the 7/16" bolt into the detent tube.
38. Insert two 5/16" x 7/8" dowel pins into the un-threaded holes in the rear of the tong, adjacent to the clutch drive gear.
39. Attach motor mount (PN 997-150) to top plate, and secure with four 1/2" UNC x 1-3/4" hex socket head cap screws.
40. Bolt the shifter lug weldment (PN 101-0016) on to the top plate with four 3/8" UNC x 1-1/2" hex bolts and 3/8" lock washers.
41. Insert the 5/16" x 5/16" x 2" motor gear key into the key-way in the motor shaft. Slide the motor gear (PN 997-A10-149) on to the to the hydraulic motor shaft and secure with two 3/8" UNC x 3/8" hex socket head set screws.
42. Install the hydraulic motor onto the motor mount. Secure the RH side of the motor to the motor mount using two 1/2" UNC x 1" hex socket head cap screws and 1/2" lock washers. Position the torque gauge holder weldment (PN 1500-09-04A) on the LH side of the motor, and secure the weldment and the motor to the motor mount using two 1/2" UNC x 1-1/4" hex bolts and 1/2" lock washers.
43. Secure the shifting handle weldment (PN 1037-D-20B) to the shifting lug weldment and the shifting shaft using one 5/16" x 1" clevis pin, and one 5/16" x 1-1/2" clevis pin. Secure the clevis pins with small "R" hitch pins or cotter pins.
44. Install the cage plates:

KT13625 Tong:

- a. Pre-grease the support ring slot in the lower cage plate (997-HT-22). Install the lower support ring (PN 997-HT-23-BOT) in the lower cage plate using eleven 3/8" x 1-3/4" socket head cap screws.
- b. Pre-grease the support ring slot in the rotary gear. Install the upper support ring (PN 997-HT-23-TOP) in the rotary gear using eleven 3/8" x 1-3/4" socket head cap screws.
- c. Pre-grease the support ring slot in the top cage plate, and set top cage plate in place, mating the support ring slot with the support ring attached to the rotary gear.
- d. Secure the bottom cage plate to the top cage plate using two 1/2" UNC x 6" hex bolts at the front, and temporarily install two jaw pivot bolts (PN 997-D3-28) at the rear of the cage plate assembly to provide support.
- e. Slide a 1/2" narrow flat washer followed by the backing pin spacer (PN 101-4093) over a 1/2" UNC x 8" hex bolt. Slide the backing pin retainer (PN 101-4139) over the backing pin spacer.
- f. Insert the 1/2" x 8" bolt and spacer assembly in the rear of the cage plate assemblies, ensuring the backing pin spacer remains between the head of the bolt and the top of the top cage plate. **ASSEMBLY NOTE:** Do not neglect to install a cage plate spacer (PN 997-38B) between the two cage plates when installing this bolt (See exploded diagram, Pp. 5.28 - 5.29).

Assembly Procedure Continued:

44. Install the cage plates (continued):

LW13625 Tong:

- a. Install eleven cam followers (02-0016) in the lower cage plate (PN 997-D2-22) using 5/8" UNF hex jam nuts and 5/8" lock washers.
- b. Install eleven cam followers in the top cage plate (PN 997-D2-21) using 5/8" UNF hex jam nuts and 5/8" lock washers.
- c. Lightly grease the top and bottom slots in the rotary gear, and set top cage plate in place, mating the cam followers on the cage plate with the slot on the rotary gear.
- d. Slide a 1/2" narrow flat washer followed by the backing pin spacer (PN 101-4093) over a 1/2" UNC x 8" hex bolt.
- e. Secure the bottom cage plate to the top cage plate. Use two 1/2" NC x 6" hex bolts at the front, and the 1/2" x 8" bolt and spacer assembly in the rear ensuring the backing pin spacer remains between the head of the bolt and the top of the top cage plate.
ASSEMBLY NOTE: Do not neglect to install the three cage plate spacers (PN 997-38B) between the two cage plates during installation (See exploded diagram Pp. 5.30 - 5.31).

45. Install backing pin:

- a. Thread the 3/8 UNC x 1-1/2" threaded stud (PN 101-4097) into the backing pin (PN 101-4042).
- b. Insert the backing pin and stud through the bottom of the backing pin retainer installed in Step 45(e). Slide the short backing pin spacer (PN 101-4096) over the top of the stud, and thread the backing pin knob (PN 02-0017) on to the top of the threaded stud.
- c. Lift the backing pin and insert into one of the two receptacles in the rear of the top cage plate.

46. Install upper and lower brake band weldments (PN 997-D23-29). Secure the brake bands to the top and bottom plates with one brake band retainer (PN 101-0140) per side - secure brake band retainers with 3/8" NC x 1" hex bolts and 3/8" lock washers. Install front adjustment springs, bolts, and nuts.

47. If not already done install the door pivot support roller components that fit within the body plates, i.e. everything except the two pivot roller shafts.

48. Install a door pivot shoulder bushings (PN 101-5110) in the top plate of each of the RH door weldment (PN 101-0034) and the LH door weldment (PN 101-0032). **ASSEMBLY NOTE:** Insert these bushings from the bottom of the top door plate so the shoulder rides between the door weldments and the top plate of the tong.

49. Insert a bottom door bushing (PN 101-5111) into the bottom plate of each door weldment.

50. Thread a 3/8" UNC hex jam nut on to a 3/8" UNC x 1-1/2" hex bolt. Thread the bolt in to the RH door weldment and lock it in place with the jam nut. This will serve as a door position adjustment.

51. Position the door latch weldment (PN 101-0038) in front of the RH door weldment, and insert two door latch springs (PN 997-16) between the two weldments. Insert the door latch adjustment cam (PN 997-A11-14) through the top plate of the RH door weldment and the latch weldment (the springs may need to be lightly compressed to facilitate the installation of the latch cam), and through the bottom plate of the RH door weldment. Secure the door latch cam to the top of the RH door weldment using a 3/8" UNC x 1" hex bolt and 3/8" lock washer. Coat the threads of a 5/8" UNF jam nut with red Loctite® and thread on to the bottom of the adjustment cam until the nut is flush with the end of the adjustment cam. See Pp. 5.32 - 5.33 for an exploded illustration of the door assembly.

52. Align the door pivot holes with the pivot holes in the top and bottom plates. Slide a 7/8" narrow flat washer over the end of both door pivot roller shafts (PN 101-0046) and insert the shafts from the top - they may have to be tapped lightly with a soft metal or rubber hammer. Use caution when sliding the shaft through the support roller components. Once the shafts have been tapped all the way through, secure each with a 3/4" UNF thin nylock nut and 7/8" narrow flat washer.

53. Install two mechanical door stops (PN 101-0014) on the underside of the tong, near the doors. Secure using two 3/8" UNC x 1-3/4" bolts and 3/8" lock washers each.

54. Install door cylinder mounting lugs (1050-12-001) into the threaded locations directly adjacent to the brake band lug weldments on the top plate.

55. Install the door spring stop cylinder assemblies (PN 101-0069) using two 1/2" x 1/2" UNC shoulder bolts.



Ensure the guards on door spring cylinders extend over the top of the support rollers rather than toward the edge of the tong.

Assembly Procedure Continued:

56. Mount the front leg mount weldments. The front leg mount weldments are coincidental with two longer support roller shafts, which were installed in step 34(a). Secure the front leg mount weldments to the support roller shafts using one 3/4" UNF thin hex nylock nut per shaft. **ASSEMBLY NOTE:** Flat washers are not used where the support roller shafts are coincidental with the front leg mount weldments.



ILLUSTRATION 3.1.8: TONG ASSEMBLY - FRONT LEG MOUNT WELDMENT INSTALLATION

57. Install the safety door components (see Pp. 5.34 - 5.35) using the following procedure:
- Attach safety door latch plate (PN 101-0320) to the LH door weldment using three 3/8" UNC x 1" hex socket head cap screws.
 - Attach safety door latch block, PN 101-0319, to the RH door weldment using two 3/8" UNC x 1-1/2" socket head countersunk cap screws and one 3/8" UNC x 1-1/2" hex bolt and lock washer.
 - Attach safety door latch block, PN AE13-301S, to safety door latch plate, PN AE13-311, using three 3/8" NC x 1" flat head countersunk cap screws.
 - Attach the assembly from step iii to the safety door latch plate, PN 101-0320, using four 5/16" x 3/4" shoulder bolts.

CE CE-marked tongs only: attach assembly from Step 56c to the safety door latch plate (PN 101-0320) t using four 5/16" x 3/4" UNC wire-drilled shoulder bolts

- Attach safety door latch block, PN AE13-302M to the safety door latch block, PN 101-0319, using four 3/8" UNC x 3/4" hex bolts.

CE CE-marked tongs only: attach safety door latch block, PN AE13-302M to the safety door latch block, PN 101-0319, using four 3/8" UNC x 3/4" wire-drilled hex bolts

- Insert load plunger, PN AE12-306, into LH safety door latch block, PN AE13-301S.

Assembly Procedure Continued:

57. Install the safety door components continued:

- g. Attach three 1/4" NPT JIC elbows to the Deltrol safety door valve, PN 08-0337M. Position a 15/16" valve lock nut as shown in illustration 3.I.9, and secure the safety door valve to the safety door latch block using the valve lock nut.

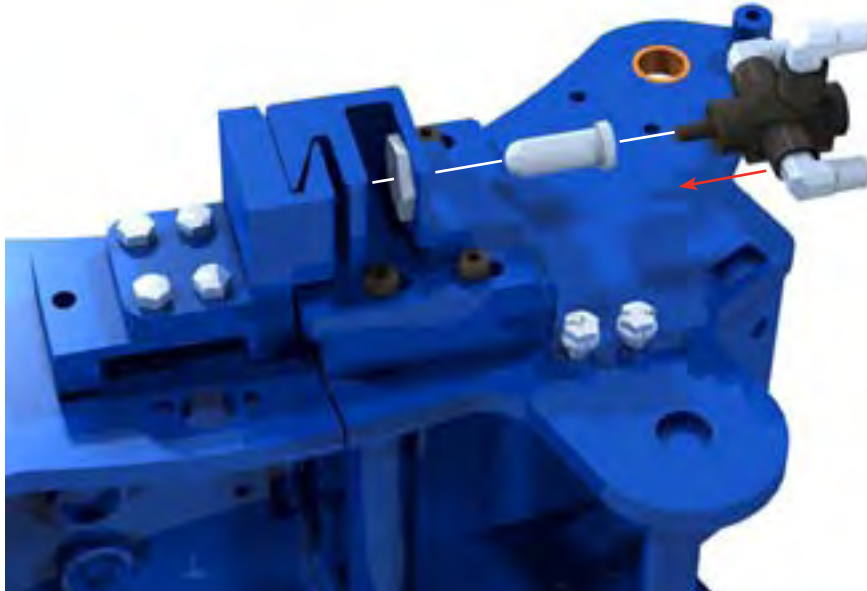

ILLUSTRATION 3.I.9: TONG ASSEMBLY - SAFETY DOOR VALVE INSTALLATION

- h. Attach the front safety door guard plate weldment, PN 101-0387, to the LH tong door weldment using two 3/8" UNC x 1" hex bolts and lock washers. Attach the rear safety door guard plate weldment, PN 101-0386, to the safety door latch plate, PN 101-0320, using a single 3/8" UNC x 1" hex bolt and lock washer. Secure the top guard plate to the front and rear plates using four 3/8" UNC x 3/4" hex bolts and lock washers. Note that a safety door adjustment may be necessary to obtain proper operation (refer to 3.F.5).

CE CE-marked tongs only: Attach the front safety door guard plate weldment, PN 101-0387, to the LH tong door weldment using two 3/8" UNC x 1" wire-drilled hex bolts and lock washers. Attach the rear safety door guard plate weldment, PN 101-0386, to the safety door latch plate, PN 101-0320, using a single 3/8" UNC x 1" wire-drilled hex bolt and lock washer. Secure the top guard plate to the front and rear plates using four 3/8" UNC x 3/4" wire-drilled hex bolts and lock washers. Note that a safety door adjustment may be necessary to obtain proper operation (refer to 3.F.5).

- 58. Install the LH & RH rigid sling mounting lugs (LH = PN 101-1361, RH = PN 101-1364) using two 3/8" UNC x 1-3/4" hex bolts and 3/8" lock washers, and two 1/2" UNC x 1-1/4" hex bolts and lock washers per side.

CE CE-marked tongs only: secure LH & RH rigid sling mounting lugs to the top plate using two 3/8" UNC x 1-3/4" wire-drilled hex bolts and 3/8" lock washers, and two 1/2" UNC x 1-1/4" wire-drilled hex bolts and lock washers per side.



ALL FASTENERS USED DURING REASSEMBLY OF LOAD-BEARING COMPONENTS (CHAIN SLINGS, RIGID SLINGS, BACKUP LEGS) MUST BE SECURED WITH RED LOCTITE™.

- 59. Slide the master lifting link (PN 02-0516) over the adjustment helix (PN 1053-1-H), and install the adjustment helix in the rigid sling weldment (PN 101-1360) using a 3/4" UNC x 9" hex bolt and 3/4" UNC nylock nut.

CE CE-marked tongs only: rigid sling weldment for CE-marked tong = PN 101-1360-CE

Assembly Procedure Continued:

60. Use a crane to hoist the rigid sling weldment. Connect the rigid sling weldment to the rigid sling mounting lugs with rigid sling pins (PN 1053-C-1C). Secure each pin with two 0.148" x 2.938" hitch pins.
61. Thread a 3/4" UNC hex nut on to each of four rigid sling leveling adjustment weldments (PN 1053-C-1L). Thread the leveling adjustment weldments into each side of the rigid sling weldment mounting brackets, roughly adjusting them so the rigid sling is approximately perpendicular to the top plate of the tong (see illustration 3.1.10).



ILLUSTRATION 3.1.10: TONG ASSEMBLY - LEVELING BOLT INSTALLATION

62. Install hydraulic inlet support base (PN 101-1138) to the top plate between the RH pinion idler and RH rotary idler using two 3/8" UNC x 1" hex bolts and 3/8" lock washers. Attach a adjustment plate (PN 101-0022) to the support base using two 3/8" UNC x 1" hex bolts, 3/8" narrow flat washers, and 3/8" UNC hex nylock nuts.
63. Attach the outlet coupling support weldment mount (PN 101-0021) to the top plate to the RH side of the motor mount using four 3/8" UNC x 1" hex socket head cap screws. Attach the outlet coupling support (PN 101-0023) to the weldment mount using two 3/8" UNC x 1" hex bolts and 3/8" lock washers. Attach a second adjustment plate (PN 101-0022) to the support base using two 3/8" UNC x 1" hex bolts, 3/8" narrow flat washers, and 3/8" UNC hex nylock nuts.

Assembly Procedure Continued:

64. Use a crane and a temporary lifting sling to transport the hydraulic valve assembly to the top of the tong. Attach to the valve mount weldments using two 1/2" UNC x 5" hex bolts and 1/2" narrow flat washers



CE-marked tongs only: Install the valve handle guard weldment (PN CE-HANDLE-3) over the valve handles while securing the valve bank to the supports (see illustration 3.I.11).

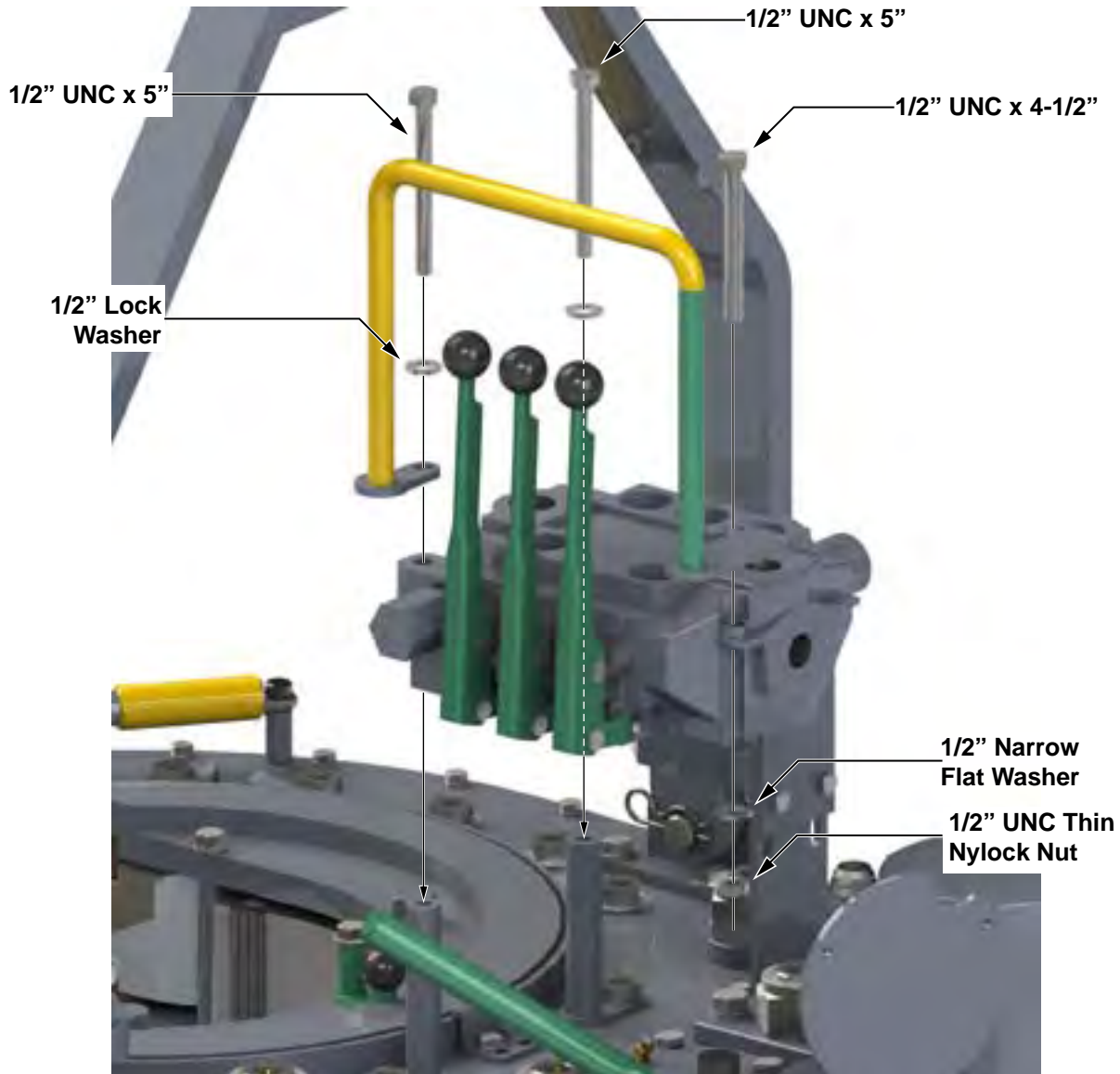

ILLUSTRATION 3.I.11: TONG ASSEMBLY - VALVE HANDLE GUARD INSTALLATION (CE MARKED TONGS)

65. Attach two #20 (1-1/4") / 1" JIC flange elbows (PN 02-9216) to the motor using #20 split flange kits (PN 02-9217).
66. Connect the safety door valve block (PN 101-0727) directly to the flange elbows on the hydraulic motor (the block will sit on top of the motor following installation). Connect the rotation control valve on the DVA35 valve assembly to the safety door block.
67. Connect the safety door switch to the safety door block and hydraulic valve assembly. Refer to hydraulic schematic, or call McCoy Drilling & Completions | Farr engineering department for assistance.
68. Install the two front leg weldments (PN 997-917-00B) in the front leg mounts and secure each with a 1/2" UNC x 4-1/2" hex bolt, 1/2" UNC hex nut, and two flat washers.

Assembly Procedure Continued:

69. Place the rear leg weldment (PN 997-915-00) on a flat section of the floor adjacent to the tong assembly. Use a crane to lift the tong assembly from its assembly base, and lower on to the leg assembly ensuring all the weight remains suspended by the crane. Secure with four 1-1/4" NC x 8" heavy hex bolts and nylock nuts.
70. Support backup assembly about waist-high off floor, ensuring the backup supports do not obstruct front leg and rear leg areas.
71. Lift tong and rear leg assembly, and lower onto backup so that the front legs lower through openings in backup. A small amount of maneuvering may be necessary to position the load cell weldment between the two rear leg plates as the tong is lowered over the backup. Continue to lower tong assembly so that roughly half the lengths of the front legs protrude through the bottom of the backup.



CE-marked tongs only: place a rubber protective washer (PN 101-5733) on the top plate of the backup over each front leg opening. The front legs will be inserted through these protective washers.

72. Slide a top spring cap, PN 1302-905-03B, over each leg, followed by the front leg springs (PN 997-906-02), and the bottom leg spring caps (PN 1302-905-03A). Secure in place with a 1/2" NC x 4-1/2" hex bolt, nut, and two flat washers. Note that the position of these bolt assemblies and the bottom spring cap may have to be adjusted when leveling the backup.
73. Attach two rear support springs (PN 1302-905-06) to the rear suspension bracket on the backup, and the U-Bolt spring holder links on the bottom plate of the rear leg.
74. Lift tong and backup assembly high enough so that the backup supports can be removed. Lower assembly until it rests on its legs.
75. Install grease fittings:
 - i. Install one 1/4" straight thread grease fitting (PN 02-0097) into the top side of each support roller shaft, including the door pivot rollers (14 locations total).
 - ii. Install one 1/4" straight thread grease fitting (PN 02-0097) into the top side of the latch adjustment cam.
 - iii. Install one 1/8" NPT grease fitting (PN 02-0005) into the top of each idler shaft or half-shaft (four locations total).
 - iv. Install one 1/8" NPT grease fitting (PN 02-0005) into the end of the clutch shaft, in the centre of the clutch bearing cap.
 - v. Install two 1/8" NPT 90° grease fittings (PN 02-0093) in each pinion bearing cap (four locations total).
 - vi. Install two 1/8" NPT 90° grease fittings (PN 02-0093) in clutch bearing cap (two locations total).
 - vii. Install one 1/8" NPT 90° grease fitting (PN 02-0093) in the top of the motor mount.
 - viii. **LW13625 ONLY:** Install one 1/8" NPT grease fitting (PN 02-0005) into each cam follower in the top and bottom cage plates (22 locations total).
 - ix. Install one 1/8" NPT grease fitting (PN 02-0005) into each cam follower in the top and bottom cage plates in the FARR® backup (22 locations total).
76. Install desired jaw die kit in the tong using the jaw pivot bolts (PN 997-D3-28).

J. DAILY INSPECTION & MAINTENANCE CHECKLIST (POWER TONG)

Farr recommends that the following inspection and maintenance procedures be performed before each use, and at least once per day when the tong is in steady use, in the order in which they are listed.

1. Rotate cage plate/rotary gear until the opening in the rotary gear faces towards the rear of the tong.



DO NOT PERFORM ANY FURTHER ACTIONS OR MAINTENANCE WHILE THE TONG IS CONNECTED TO ANY HYDRAULIC POWER SUPPLY. FARR RECOMMENDS THAT ALL HYDRAULIC LINES ARE FULLY DISCONNECTED, AND RESIDUAL HYDRAULIC PRESSURE IS BLED OFF. ENSURE ADEQUATE CONTAINMENT IS IN PLACE TO PREVENT ENVIRONMENTAL CONTAMINATION FROM RESIDUAL HYDRAULIC FLUID.

DEPRESSURIZE HYDRAULIC SYSTEM IN PREPARATION FOR MAINTENANCE:

2.
- 1) Rotate the tong to the "open throat" position. Ensure tong and backup doors (if equipped) are closed. Fully extend the lift cylinder
 - 2) De-energize the power unit.
 - 3) Repeatedly actuate the tong motor control valve lever **IN BOTH DIRECTIONS** to dissipate any residual pressure in the valve and motor.
 - 4) Remove the hydraulic SUPPLY line from the equipment.
 - 5) Repeatedly actuate the remaining control valve levers **IN BOTH DIRECTIONS** to dissipate any residual pressure in the remainder of the hydraulic control system.
 - 7) Disconnect the hydraulic RETURN line from the equipment.
 - 8) Disconnect remaining hoses such as case drains.



HYDRAULIC PRESSURES AS HIGH AS OPERATING PRESSURE MAY REMAIN TRAPPED IN SMALL AREAS OF THE EQUIPMENT. ENSURE ALL MAINTENANCE IS CARRIED OUT BY A QUALIFIED SERVICE TECHNICIAN, AND THAT ADEQUATE PERSONAL PROTECTIVE EQUIPMENT IS USED TO GUARD AGAINST PRESSURE INJURIES

3. Perform an initial wash of the tong in order to remove the majority of dirt and grease build-up. Ensure adequate containment is in place to prevent environmental contamination from residual hydraulic fluid and dirty grease.
4. Remove the access panel on the side of the tong directly adjacent to the shifter mechanism.
5. Use a flashlight to perform a visual inspection of the gear train through the access panel and the opening of the rotary gear. If gear damage or chips of metal are seen, the tong should be removed from service and overhauled to avoid further damage. Replace access panel when inspection is complete.
6. Perform a visual inspection of all fasteners and protruding body pieces (example: hydraulic valve mounts, inlet & outlet line supports, tong legs, shifter handle pivot lugs). Tighten or replace loose or missing fasteners. Farr recommends that damaged or missing body parts be repaired or replaced.
7. Inspect the jaws and dies. Inspect the jaw roller pins for signs of damage - replace pins if necessary. If the pins are welded in place, replace the entire jaw assembly. Ensure dies are secure in the jaw - replace worn dies if necessary. Ensure that the jaw rollers rotate freely. Check to ensure the size of the loaded jaws match the size of casing or pipe you are running.
8. Perform a visual inspection of all lifting points - if visible damage is seen, including cracks, broken lugs, distorted metal, etc. replace damaged part(s) before placing tong in service. Also inspect all chains, master links, and turnbuckles - again, if any damage is noted replace the damaged part(s) before placing the tong in service.
9. Inspect tong for signs of premature wear, or moving parts that are rubbing (bare metal where there used to be paint is a good indication of wear).
10. Inspect backing pin(s). If cracked, broken, or bent it (they) must be replaced.
11. Inspect top and bottom brake band linings - replace if necessary. Unequal wear of the brake bands indicates that the brake band tension is not evenly adjusted. Refer to the maintenance section of the manual for instructions on properly adjusting brake bands.
12. Perform a visual inspection of all hydraulic lines. Replace flexible lines if they appear to be cracked, fatigued, or have visible signs of wear from contact with a rigid object.

- 13. Perform a complete greasing of the tong - refer to Maintenance section of the technical manual
- 14. Ensure main supply and return connections to the tong are fully made up. Re-connect the remainder of the hydraulic lines, and, if applicable, the electrical line to the turns counter.



FAILURE TO ENSURE THAT THE SELF-SEALING SUPPLY AND RETURN LINES ARE FULLY MADE UP MAY RESULT IN CATASTROPHIC EQUIPMENT FAILURE.

- 15. Perform a visual inspection of the load cell. If using a tension load cell, replace any cracked, broken, or distorted components including links and chains. If using a compression load cell, replace any component that has been crushed or otherwise distorted through compression. Inspect hydraulic line, fittings, and diaphragm seals for fluid leaks.
- 16. If applicable, inspect the load cell anchor pins (tension load cell only). Replace the anchor pins if cracking or metal distortion is seen.

If using a stand-alone power unit, start it now - refer to the power unit technical manual for startup procedures. Listen to power unit for a moment to see if there are any unusual mechanical sounds (rubbing, grinding, excessive pump noise). If using a diesel unit, allow sufficient time for the engine to reach operating temperature before increasing engine RPM. Once engine is warm, gradually increase engine RPM until operating speed is reached.

- 17. Ensure that supply pressure is at or above the tong's specified operating pressure, and that the return pressure is less than 350 psi.
- 18. Perform a visual inspection of pressurized hydraulic lines. Document and correct any hydraulic fluid leaks.
- 19. Perform a full functional test of the tong (refer to section 2.1.4).

- 20. Test safety door feature (if equipped). Open the tong door(s), and attempt to rotate the cage plate at low speed (low gear) in both directions (makeup and breakout). If cage plate begins rotating, the safety door mechanism is not functional, and the tong must be removed from service until the safety door mechanism can be repaired. If the safety door is operating correctly, cage plate rotation will not be inhibited once the door is closed and latched.



NEVER OPERATE YOUR EQUIPMENT WITH A BYPASSED OR MALFUNCTIONING SAFETY DOOR

- 21. While rotating the cage plate, ensure that the jaws properly cam. If the jaws do not cam properly, the brake bands need to be tightened. Incrementally adjust both the top and bottom brake bands EQUALLY until proper cam action is achieved.



CE-marked tongs only: Inspect all wire-ties on drilled bolts on critical safety systems. All wiring must be intact and appear tamper-free. Check the integrity of all guards, including the rubber protective washers over the backup leg openings.

K. DAILY INSPECTION & MAINTENANCE CHECKLIST (BACKUPS)

Farr Canada recommends that the following inspection and maintenance procedures be performed before each use, and at least once per day when the backup is in steady use, in the order in which they are listed.

Do not perform any maintenance while the tong and backup assembly is connected to any hydraulic power supply. Farr Canada recommends that all hydraulic lines are fully disconnected, and residual hydraulic pressure is bled off. Ensure adequate containment is in place to prevent environmental contamination from residual hydraulic fluid.

ALL UNITS

1. Perform an initial wash of the backup in order to remove the majority of dirt and grease build-up.
2. Perform an external inspection. Check to ensure there are no loose or missing fasteners - replace if necessary.
3. Check to see if backup is parallel to the tong - if the backup is resting at an angle, one of the front leg springs is likely broken or fatigued to the point it must be replaced.

WEDGE BACKUP ONLY

4. Remove access cover from top plate. Perform a visual inspection of the interior of the backup - use a flashlight if necessary. Premature wear where there are moving parts (bare metal where there used to be paint, and metal shavings in the grease are good indicators) may show where a component needs to be adjusted, or if necessary, replaced.
5. Inspect latch mechanism to ensure the door latch plate completely engages the door. Adjust or replace if necessary.
6. Grease UC-300 slider pads, ram guides, door cylinder pivots, and door pivots.

CLINCHER BACKUP ONLY

4. Use a flashlight to perform a visual inspection of the interior of the backup - remove one side panel if necessary. Premature wear where there are moving parts (bare metal where there used to be paint, and metal shavings in the grease are good indicators) may show where a component needs to be adjusted, or if necessary replaced. Replace any removed panels when inspection is complete.
5. Grease clincher cylinder guides using the grease fittings on the top body plate.
6. Ensure the splines on the clincher cylinder faces, and on the rear of the die are clean and free of debris before inserting clincher die. If die are already installed, ensure fasteners in the die retainers are tightly secured.
7. Inspect rear spring hanger assembly. Ensure all eye bolts, shackles, and cotter pins are in place and in good condition.
8. Inspect clincher cylinders for hydraulic fluid leaks once the system pressure has been restored.

FARR-STYLE BACKUP ONLY

4. Inspect cam ring gear for broken teeth.
5. Lubricate the cam follower array.
6. Inspect the jaws and dies. Inspect the jaw roller pins for signs of damage - replace pins if necessary. If the pins are welded in place, replace the entire jaw assembly. Ensure dies are secure in the jaw - replace worn dies if necessary. Ensure that the jaw rollers rotate freely. Check to ensure the size of the loaded jaws match the size of casing or pipe you are running.
7. Inspect front and rear cam cylinder supports. Repair or replace any parts that are broken, cracked, or bent.
8. Inspect rear spring hanger assembly. Ensure all eye bolts, shackles, and cotter pins are in place and in good condition.
9. Open the backup door and inspect the condition of the latch. Repair or replace damaged latch components. If latch appears to be in good condition, close the door, then tug firmly on it to ensure the door remains latched.

ALL UNITS (AFTER STARTING POWER UNIT)

10. Perform a visual inspection of pressurized hydraulic lines - document and correct any hydraulic fluid leaks.
11. Perform a full functional test of the backup. Document and correct hydraulic leaks from the hydraulic valve bank, or from any hydraulic cylinders that are in use on the backup.

L. MONTHLY MAINTENANCE CHECKLIST - POWER TONG

The following maintenance checklist is intended as a guideline rather than a definitive maintenance schedule. Your equipment may require more, or less, maintenance depending upon the frequency of use, the percentage of maximum torque that your equipment is routinely subjected to, and the field conditions under which your equipment operates. Farr recommends that the following inspection and maintenance procedures be performed monthly, or in conjunction with your maintenance foreman's experience and best estimate of when your equipment is due for this maintenance.

1. Rotate cage plate/rotary gear until the opening in the rotary gear faces towards the rear of the tong.



DO NOT PERFORM ANY FURTHER ACTIONS OR MAINTENANCE WHILE THE TONG IS CONNECTED TO ANY HYDRAULIC POWER SUPPLY. FARR RECOMMENDS THAT ALL HYDRAULIC LINES ARE FULLY DISCONNECTED, AND RESIDUAL HYDRAULIC PRESSURE IS BLED OFF. ENSURE ADEQUATE CONTAINMENT IS IN PLACE TO PREVENT ENVIRONMENTAL CONTAMINATION FROM RESIDUAL HYDRAULIC FLUID.

DEPRESSURIZE HYDRAULIC SYSTEM IN PREPARATION FOR MAINTENANCE:

- 1) De-energize the power unit.
- 2) Repeatedly actuate the tong motor control valve lever **IN BOTH DIRECTIONS** to dissipate any residual pressure in the valve and motor.
2. 3) Remove the hydraulic **SUPPLY** line from the equipment.
- 4) Repeatedly actuate the remaining control valve levers **IN BOTH DIRECTIONS** to dissipate any residual pressure in the remainder of the hydraulic control system.
- 5) Disconnect the hydraulic **RETURN** line from the equipment.
- 6) Disconnect remaining hoses such as case drains, or lines connected to the turns counter.



HYDRAULIC PRESSURES AS HIGH AS OPERATING PRESSURE MAY REMAIN TRAPPED IN SMALL AREAS OF THE EQUIPMENT. ENSURE ALL MAINTENANCE IS CARRIED OUT BY A QUALIFIED SERVICE TECHNICIAN, AND THAT ADEQUATE PERSONAL PROTECTIVE EQUIPMENT IS USED TO GUARD AGAINST PRESSURE INJURIES

3. Clean the exterior of the tool thoroughly, using either water (if using a pressure washer ensure a low-pressure wash wand is used), or an appropriate solvent-based grease-cutting cleaner such as Varsol. Ensure adequate containment is in place to prevent environmental contamination from residual hydraulic fluid, dirty grease, and cleaning agents.
4. Remove the access panel on the side of the tong directly adjacent to the shifter mechanism.
5. Clean the interior of the tong thoroughly, using either water (do not use a pressure washer), or an appropriate solvent-based grease-cutting cleaner such as Varsol. Ensure adequate containment is in place to prevent environmental contamination from residual hydraulic fluid, dirty grease, and cleaning agents. Make a note if any metal shavings or metal pieces are flushed out of the gear train cavity - if shavings or metal pieces are seen the tong must be overhauled before it is returned to service.
6. Inspect all fasteners and fastener safety wires (if equipped). Replace any missing fasteners - use Grade 8 bolts only unless otherwise specified. Re-torque all external fasteners to SAE specifications.
7. Repair or replace any damaged or missing external body parts, such as torque gauge mounts, hydraulic supports, safety door protectors, etc.
8. Perform a visual inspection of all fasteners and protruding body pieces (example: hydraulic valve mounts, inlet & outlet line supports, tong legs, shifter handle pivot lugs). Tighten or replace loose or missing fasteners.
9. Inspect tong for signs of premature wear, or moving parts that are rubbing (bare metal where there used to be paint is a good indication of wear).
10. Inspect all paint - locations in which the paint has been damaged must be repaired prior to the tong being returned to service. Prepare areas to be painted to ensure they are free of grease, dirt, or solvent. Touch up using a solvent-based acrylic paint - "McCoy Grey" is paint color number RAL7015, "McCoy Yellow" (hazard areas) is RAL1007, and McCoy Green is RAL6029 (contact Farr sales for paint number for custom paint applications). Allow sufficient time for paint to dry before proceeding.
11. Visually inspect all load-bearing welds. Any weld that is cracked or separating must be repaired and repainted before returning the tong to service.
12. Perform a visual inspection of all lifting points - if visible damage is seen, including cracks, broken lugs, distorted metal, etc. replace damaged part(s) before placing tong in service. Also inspect all chains, master links, and turnbuckles - again, if any damage is noted replace the damaged part(s) before placing the tong in service. Refer to Section 2A of the technical manual (Sling/Load Bearing Device Safety) for information on recommended testing and recertification. Please note that turnbuckles with part number 101-3086 (short turnbuckles) use a high-strength pin which must be supplied by Farr.



“SHORT” TURNBUCKLES HAVING PART NUMBER 101-3086 EMPLOY HIGH-STRENGTH PINS WHICH MUST BE SUPPLIED BY FARR.

13. Remove hydraulic motor and rotate the gear train by hand, and use a flashlight to perform a visual inspection of the gear train through the access panel and the opening of the rotary gear while the gear train is being rotated. If gear damage or chips of metal are seen, the tong should be removed from service and overhauled to avoid further damage. Replace access panel when inspection is complete.
14. Inspect all jaws and dies in use for the maintenance interval. Remove pin & roller, and inspect for signs of damage - replace pins if necessary. If the pins are welded in place & the welds are found to be damaged, remove and quarantine the jaw until the weld is repaired. Clean the pins and rollers, and reassemble using a liberal coating of anti-seize compound. Ensure dies are secure in the jaw & die retainers are present. Replace worn dies if necessary. Ensure that the jaw rollers rotate freely.
15. Inspect backing pin(s). If cracked, broken, or bent it (they) must be replaced.
16. Inspect top and bottom brake band linings - replace if lining is found to be flaking or is missing pieces of material. Unequal wear of the brake bands indicates that the brake band tension is not evenly adjusted. Refer to the maintenance section of the manual for instructions on properly adjusting brake bands.
17. Inspect door springs. Ensure the springs retain sufficient strength to be able to assist the opening of the door, and to keep the door open. The springs should also help to “snap” the door shut.
18. Inspect backup springs (if applicable). The rear extension springs (where used) should be equally extended, and the front leg springs should be equally compressed. Ensure that neither of the rear backup springs have been over-extended and lack sufficient tension to adequately support the backup. Ensure that neither of the front leg springs (or, when installed, the single rear backup leg spring) have been over-compressed, and still retain enough spring strength to support the front of the backup.
19. Extend all hydraulic cylinders, and inspect cylinder rods for signs of mechanical damage, flaking, or rust. Farr recommends that damaged cylinders be replaced prior to storage.
20. Perform a visual inspection of all hydraulic lines. Replace flexible lines if they appear to be cracked, fatigued, or have visible signs of wear from contact with a rigid object. If your tong is equipped with rigid hydraulic lines, replace any line that is dented or appears to be stressed or cracked.
21. Generously fill the gear train housing with grease through the access panel, and also through the opening in the rotary gear. Perform a full lubrication - refer to Maintenance section of manual to determine lubrication points.
22. Ensure main supply and return connections to the tong are fully made up. Re-connect the remainder of the hydraulic lines.



FAILURE TO ENSURE THAT THE SELF-SEALING SUPPLY AND RETURN LINES ARE FULLY MADE UP MAY RESULT IN CATASTROPHIC EQUIPMENT FAILURE.

If using a stand-alone power unit, start it now - refer to the power unit technical manual for startup procedures. Listen to power unit for a moment to see if there are any unusual mechanical sounds (rubbing, grinding, excessive pump noise). If using a diesel unit, allow sufficient time for the engine to reach operating temperature before increasing engine RPM. Once engine is warm, gradually increase engine RPM until operating speed is reached.

23. Ensure that supply pressure is at or above the tong’s specified operating pressure, and that the return pressure is less than 350 psi.
24. Perform a visual inspection of pressurized hydraulic lines. If any hydraulic fittings or hoses are leaking they must be repaired or replaced before proceeding.
25. Rotate tong for one minute in both high and low gear. Stop the tong and reverse the direction of rotation for another minute in both high and low gear, ending with the opening of the rotary gear facing the gear train. De-energize the power unit, and perform another generous lubrication of the gear train, including the gear housing.
26. Energize power unit. Rotate tong for one minute in both high and low gear. Stop the tong and reverse the direction of rotation for another minute in both high and low gear, ending with the opening of the rotary gear facing the gear train.
27. De-energize the power unit, and perform a third generous lubrication of the gear train, including the gear housing.
28. Rotate tong in low gear for 5 minutes while monitoring pressurized seals and hydraulic lines. If a seal, line, or fitting begins to leak while tong is rotating, it must be replaced before the equipment is returned to service.
29. Rotate tong in high gear for 5 minutes while monitoring temperature of top and bottom bearing caps. If the bearing caps are hot to the touch (higher than approximately 50°C) replace the applicable bearings. Likewise if the tong is making unusual noises check for damaged bearings (see Maintenance Manual for all bearing locations).

- 30. *Install load cell. If using a tension load cell, perform a visual inspection and replace any cracked, broken, or distorted components including links and chains. If using a compression load cell, replace any component that has been crushed or otherwise distorted through compression. Inspect load cell for damage or signs of stress. Check oil level in load cell and fill if necessary (refer to technical manual Section 7 or Section 8).*
- 31. *If applicable, inspect the load cell anchor pins (tension load cell only). Replace the anchor pins if cracking or metal distortion is seen.*
- 32. *If applicable, the weld securing the single load cell anchor to the bridge bar main plate must be inspected (compression load cell only). If the integrity of the weld has been compromised, the tong must be removed from service until the weld is repaired. The load cell beam will need to be disconnected and removed so the weld is visible. Before re-installing the beam, liberally grease the anchor pin before reinserting into the load cell beam.*
- 33. *While rotating the cage plate, ensure that the jaws properly cam. If the jaws do not cam properly, the brake bands need to be tightened. Incrementally adjust both the top and bottom brake bands EQUALLY until proper cam action is achieved. Refer to the maintenance section of the manual for instructions on properly adjusting brake bands.*
- 34. *Perform a full functional test of the tong including, if applicable, backup components, lift cylinder, and float frame components (refer to Section 2.1.4). Report and correct any hydraulic leaks from the hydraulic valve bank, or from any hydraulic cylinders that are used.*
- 35. *Test safety door feature (if equipped). Begin rotating the tong at low speed, and open the tong door(s). If rotation does not immediately stop, this is an indication that the safety door mechanism is not operating correctly and the tong must be removed from service until the mechanism is repaired. Repeat the test while operating the tong in the opposite direction. If the safety door is operating correctly, cage plate rotation will not be inhibited once the door is closed and latched.*



NEVER OPERATE YOUR EQUIPMENT WITH A BYPASSED OR MALFUNCTIONING SAFETY DOOR

- 36. *Farr recommends that an anti-corrosive agent such as Tectyl® 506 be applied to all external unpainted surfaces (and chain slings) EXCEPT cylinder rods, jaw rollers, and rotary gear camming surfaces. Refer to manufacturer data sheets for proper application and safety information.*

Once all of the above maintenance checklist items have been satisfactorily completed the tool may be returned to service.

M. TUBULAR CONNECTION EQUIPMENT DE-COMMISSIONING & SHIPPING

Perform the following decommissioning procedures when removing tubular connection equipment from service, with the intent of short to long-term storage. These procedures are essential for ensuring proper protection of the equipment from environmental attack, and to aid in the quick turnaround when returning the equipment to service.

Store all o-rings, seals, packings, gaskets, etc. in strong moisture proof, airtight containers. Ensure that these items are not crushed, nicked, or otherwise damaged.

Do not perform any further actions or maintenance while the tong is connected to any hydraulic power supply. Farr recommends that all hydraulic lines are fully disconnected, and residual hydraulic pressure is bled off. Ensure adequate containment is in place to prevent environmental contamination from residual hydraulic fluid.



IN ORDER TO MAINTAIN THE INTEGRITY OF INSTALLED SEALS, MCCOY RECOMMENDS THAT THE MAXIMUM STORAGE INTERVAL NOT EXCEED ONE YEAR. AT LEAST ONCE PER YEAR ALL TUBULAR CONNECTION EQUIPMENT IN LONG-TERM STORAGE SHOULD BE RECOMMISSIONED AS PER SECTION 3.M. IF FURTHER STORAGE IS REQUIRED, THE EQUIPMENT SHOULD THEN BE PUT THROUGH ANOTHER DE-COMMISSIONING PROCEDURE.

DEPRESSURIZATION PROCEDURE IN PREPARATION FOR STORAGE:

- 1) Rotate the tong so that the opening in the rotary gear faces the gear train (towards the rear of the tong). Ensure tong and backup doors (if equipped) are closed. Fully extend the lift cylinder (if equipped). If mounted in a frame, retract the float cylinders (if equipped).
- 2) De-energize the power unit.
- 3) Repeatedly actuate the tong motor control valve lever IN BOTH DIRECTIONS to dissipate any residual pressure in the valve and motor.
- 4) Remove the hydraulic SUPPLY line from the equipment.
- 5) Repeatedly actuate the remaining control valve levers IN BOTH DIRECTIONS to dissipate any residual pressure in the remainder of the hydraulic control system.
- 7) Disconnect the hydraulic RETURN line from the equipment.
- 8) Disconnect remaining hoses such as case drains, or lines connected to the turns counter.



HYDRAULIC PRESSURES AS HIGH AS OPERATING PRESSURE MAY REMAIN TRAPPED IN SMALL AREAS OF THE EQUIPMENT. ENSURE ALL MAINTENANCE IS CARRIED OUT BY A QUALIFIED SERVICE TECHNICIAN, AND THAT ADEQUATE PERSONAL PROTECTIVE EQUIPMENT IS USED TO GUARD AGAINST PRESSURE-INDUCED INJURIES

1. Perform an initial wash of the tool in order to remove the majority of dirt and grease build-up. Ensure adequate containment is in place to prevent environmental contamination from residual hydraulic fluid and dirty grease.
2. Remove the access panel on the side of the tong directly adjacent to the shifter mechanism.
3. Clean the interior of the tong thoroughly, using either water (do not use a pressure washer), or an appropriate solvent-based grease-cutting cleaner such as Varsol. Ensure adequate containment is in place to prevent environmental contamination from residual hydraulic fluid, dirty grease, and cleaning agents. Make a note if any metal shavings or metal pieces are flushed out of the gear train cavity - if shavings or metal pieces are seen the tong must be overhauled before it is returned to service.
4. Clean the exterior of the tool thoroughly, using either water (do not use a pressure washer), or an appropriate solvent-based grease-cutting cleaner such as Varsol. Ensure adequate containment is in place to prevent environmental contamination from residual hydraulic fluid, dirty grease, and cleaning agents.
5. Inspect all fasteners and fastener safety wires. Replace any missing fasteners - use Grade 8 bolts only. Re-torque all external fasteners to SAE specifications.
6. Inspect backing pin(s). If cracked, broken, or bent it (they) must be replaced.
7. Repair or replace any damaged or missing external body parts, such as torque gauge mounts, hydraulic supports, safety door protectors, etc.
8. Inspect all paint - locations in which the paint has been damaged must be repaired prior to storage. Prepare areas to be painted to ensure they are free of grease, dirt, or solvent. Touch up using a solvent-based acrylic paint - "McCoy Grey" is paint number RAL7015. Allow sufficient time for paint to dry before proceeding.
9. Perform a liberal lubrication of the equipment - refer to Maintenance section of manual to determine lubrication points. Generously fill the gear train housing with grease through the access panel, and also through the opening in the rotary gear.
10. Connect the equipment to a hydraulic power unit. Ensure all lines are fully made up to prevent equipment damage from excessive back pressure. Do not neglect to connect the motor drain.
11. Energize power unit.

- 12. Rotate tong for one minute, stop, and reverse the direction of rotation for another minute, ending with the opening of the rotary gear facing the gear train. De-energize the power unit, and perform another generous lubrication of the gear train, including the gear housing.
 - 13. Energize power unit. Rotate tong for one minute, stop, and reverse the direction of rotation for another minute, ending with the opening of the rotary gear facing the gear train.
 - 14. De-energize the power unit, and perform a third generous lubrication of the gear train, including the gear housing.
 - 15. Energize power unit, and rotate the tong for a final time, one minute in one direction, stop, and reverse the direction of rotation for another minute, this time ending with the rotary gear in the "open throat" position.
 - 16. Extend all hydraulic cylinders, and inspect cylinder rods for signs of mechanical damage, flaking, or rust. Farr recommends that damaged cylinders be replaced prior to storage.
- If you are using a frame-mounted tool, the tong must be lowered onto the backup in order to remove the risk of sudden and catastrophic movement when pressure is removed from the float cylinders. Cover the top of the backup with protective cloth to protect the paint on the backup. Place two wooden beams across the top of the tong, ensuring that the beams have a minimum size of 4" x 4" x the width of the tong. Cover the tops of the wooden beams with more protective cloth to prevent paint damage to the tong. When lowering the tong onto the beams, ensure that the beams come into flat contact with the bottom of the tong, away from bearing caps, brake bands, or other protrusions on the bottom of the tong. Ensure that the tong hanger chains are loose, but not dangling into contact with the hangers or top plate of the tong.

DEPRESSURIZATION PROCEDURE FOR STORAGE:

- 1) Rotate the tong to the "open throat" position.
 - 2) Exercise each hydraulic cylinder several times - open the tong and backup doors (if equipped), retract and extend the remote backing pin ramp (if equipped), retract and extend the float cylinders. Leave all cylinders except for the door cylinders in their fully retracted position. The general idea is to have as little of the chrome cylinder rods exposed as possible.
 - 3) De-energize the power unit.
 - 4) Repeatedly actuate the tong motor control valve lever IN BOTH DIRECTIONS to dissipate any residual pressure in the valve and motor.
 - 5) Remove the hydraulic SUPPLY line from the equipment.
 - 6) Repeatedly actuate the remaining control valve levers IN BOTH DIRECTIONS to dissipate any residual pressure in the remainder of the hydraulic control system.
 - 7) Connect a low-pressure air supply line (10 PSI or less) to the hydraulic supply line, and force a small amount of the remaining hydraulic fluid from the valve assembly - this will allow for thermal expansion of the hydraulic fluid if the equipment is stored or transported in high ambient temperatures. Failure to do this may result in damaged or destroyed seals in the equipment.
 - 8) Disconnect the hydraulic RETURN line from the equipment.
 - 9) Disconnect remaining hoses such as case drains, or lines connected to the turns counter.
- 18. If any hydraulic fittings or hoses are leaking they must be repaired or replaced before proceeding.
 - 19. Wipe all excess grease from outside of equipment. Replace the access door panel. Use a solvent-based cleaner on rags to wipe all external surfaces to remove residual grease or hydraulic fluid. Once the outside surfaces have been de-greased, wipe all external surfaces with clean water to remove residual solvent.
 - 20. Farr recommends that chain slings be removed and stored separately. Rigid slings and other rigid suspension devices may remain in place.
 - 21. Apply grease or heavy oil to all exposed cylinder rods.
 - 22. Farr recommends that an anti-corrosive agent such as Tectyl® 506 be applied to all external surfaces EXCEPT cylinder rods (including chain slings). Refer to manufacturer data sheets for proper application and safety information.



DO NOT ALLOW ANTI-CORROSIVE AGENTS TO CONTACT CYLINDER RODS. CYLINDER ROD DAMAGE WILL OCCUR.

- 23. Allow the anti-corrosive coating ample time to dry - refer to manufacturer data sheets for drying times at room temperature.
- 24. Wrap entire assembly in 100 gauge (1 mil) corrosion-inhibiting wrap, at least 3 layers thick. Attempt to ensure that the tool is well-sealed within the wrapping, including the bottom.

If possible, store in a sealed, climate controlled environment. If isolated storage is not available, Farr recommends storing your wrapped equipment in a secure, out-of-the-way location, using silica gel desiccant to reduce the humidity within the wrapping. As a guideline, use 125 g. of desiccant for each cubic metre of space, or 3.5 g. per cubic foot (see calculations next page).

CALCULATION OF REQUIRED DESICCANT

- 1) Calculate the trapped air volume by measuring the outside dimensions of the tool to be stored, and treat that as the volume to be stored. For example, the external dimensions of a KT20000 20" power tong are 80.25" x 50.5" x 28", which calculates to an approximate volume of 113500 in³, or 66 ft³ (1.87 m³).
- 2) Multiply the calculated air volume, in cubic feet, by the recommended amount of desiccant per cubic foot. Carrying forth the example used in the previous step, the required desiccant charge would be 3.5 g. x 66 ft³, equaling 231 g. Several manufacturers offer silica gel desiccant in packaged quantities of 125 grams per bag, so two packages of desiccant would be required. Please keep in mind that this is a guideline only - more or less desiccant may be required in extreme environmental conditions.

For best corrosion resistance the equipment should be removed from storage and exercised on a regular basis, depending on the storage environment. Farr recommends that for equipment stored in a salt-water maritime or exposed dusty environment, repeat steps 9 through 24 monthly. For equipment stored in isolated storage in a non-maritime environment, repeat steps 9 through 24 quarterly. Replace desiccant packs at this time - depleted desiccant packs may be treated as regular dunnage.

SHIPPING INSTRUCTIONS

The following procedure lists the steps to be followed to prepare your tong for shipping.

1. If not already done remove accessories (tong jaws, load cell, torque gauge, etc.) McCoy recommends wrapping these items in protective wrap and placing in a separate wooden crate.
2. Place the equipment on a sturdy pallet constructed of 4" x 4" cross-members and 2" x 4" flooring. McCoy recommends placing a 2" x 6" board across the width of the tong under the legs (see Illustration 3.M.1). Ensure the pallet is large enough to accommodate the wooden crate containing the tong accessories.



ILLUSTRATION 3.M.1: SHIPPING INSTRUCTIONS - PALLET

SHIPPING INSTRUCTIONS (CONTINUED):

3. Use a crane to support the chain sling (if equipped). Wrap the chain sling with bubble wrap or another similar protective wrapping, and secure the wrapping with tape. Lower the wrapped chain sling so it sits inside the opening of the tong.

**ILLUSTRATION 3.M.2: SHIPPING INSTRUCTIONS - WRAPPING CHAIN SLING**

4. Do not allow the backup (if equipped) to "float" on its support springs during shipping. Build a sturdy wooden support structure under the front and back of the backup to support the weight of the backup and release the compression on the springs. Strap the backup to the support blocks and pallet independent of the tong, using minimum 3/4" x 0.029" metal strapping in at least two locations. Place strapping as close to the backup supports as possible, and use caution not to entrap any flexible hydraulic hoses beneath the strapping. Before tightening strapping, place strapping protectors wherever the metal strapping comes into contact with the equipment.

**ILLUSTRATION 3.M.3: SHIPPING INSTRUCTIONS - BACKUP SUPPORT**

SHIPPING INSTRUCTIONS (CONTINUED):

5. Securely strap the equipment in place using metal strapping. Place strapping as close to the cross-members under the equipment legs as possible, and use caution not to entrap any flexible hydraulic hoses beneath the strapping (guide strapping through beneath the hydraulic hoses). Use the following guidelines to determine the strapping requirements:

Assemblies weighing 1000 lbs. (454 kg.) or less:

3/4" x 0.029" metal strapping, 3320 lbs. (1509 kg.) tensile strength
Minimum two straps

Assemblies weighing more than 1000 lbs. (454 kg.) or less:

1-1/4" x 0.031" metal strapping, 5500 lbs. (2500 kg.) tensile strength
Minimum **two** straps for assemblies weighing less than 5000 lbs. (2273 kg.)
Minimum **three** straps for assemblies weighing more than 5000 lbs. (2273 kg.)

Before tightening strapping, place strapping protectors wherever the metal strapping comes into contact with the equipment.

Place the wooden crate containing the tong accessories on the crate next to the equipment. Strap the crate to the pallet using 3/4" x 0.029" metal strapping (see Illustration 3.M.4).



ILLUSTRATION 3.M.4: SHIPPING INSTRUCTIONS - STRAPPING EQUIPMENT TO PALLET

If it is not practical to place larger loose items in a wooden crate, ensure they are also securely strapped to the pallet using 3/4" x 0.029" metal strapping.

6. Use a large polyethylene shipping bag (sometimes called a pallet cover) to completely enclose the equipment. Seal polyethylene bag to the pallet using 1 mil polyethylene wrap. Use the wrap to conform the plastic cover to the general shape of the equipment, but do not wrap so tight that sharp edges on the equipment perforate the cover.
7. McCoy recommends enclosing the equipment in a sturdy shipping crate which is securely fastened to the pallet.

N. TUBULAR CONNECTION EQUIPMENT RE-COMMISSIONING PROCEDURE

Perform the following recommissioning procedures when removing tubular connection equipment from short or long-term storage back into regular service. These procedures are essential for ensuring proper equipment preparation and operation. The following procedures also assume that the decommissioning and storage procedures recommended by Farr have been strictly observed.

1. Remove all protective plastic wrapping. If there are desiccant packs with the assembly, they may be disposed of with the regular garbage.
2. Remove the access panel on the side of the tong directly adjacent to the shifter mechanism.
3. Wipe excess grease or heavy oil from exposed cylinder rods.
If applicable, re-connect chain sling to lifting lugs. Perform a visual inspection of all lifting points - if visible damage is seen, including cracks, broken lugs, distorted metal, etc. replace damaged part(s) before placing tong in service. Also inspect all chains, master links, and turnbuckles - again, if any damage is noted replace the damaged part(s) before placing the tong in service. If your company requires yearly certification of lifting equipment, ensure that the most recent test date falls within the past year. Perform recertification if necessary.
4. Perform a liberal lubrication of the equipment - refer to Maintenance section of manual to determine lubrication points. Generously fill the gear train housing with grease through the access panel, and also through the opening in the rotary gear.
5. Connect the equipment to a hydraulic power unit. Ensure all lines are fully made up to prevent equipment damage from excessive back pressure. Do not neglect to connect the motor drain.



FAILURE TO ENSURE THAT THE SELF-SEALING SUPPLY AND RETURN LINES ARE FULLY MADE UP MAY RESULT IN CATASTROPHIC EQUIPMENT FAILURE.

7. Energize power unit.
8. Ensure that supply pressure is at or above the tong's specified operating pressure, and that the return pressure is less than 350 psi.
9. Perform a thorough inspection of pressurized hydraulic lines and fittings. Any leaking hydraulic fluid lines or fittings must be replaced before the equipment is returned to service.
10. Perform a thorough inspection of all seals. Any seal that is leaking or "weeping" must be replaced before the equipment is returned to service.
11. Rotate tong in low gear for 5 minutes while monitoring pressurized seals and hydraulic lines. If a seal, line, or fitting begins to leak while tong is rotating, it must be replaced before the equipment is returned to service. Finish this step with the rotary gear opening facing the gear train. De-energize the power unit.
12. Inspect all flexible hydraulic lines for signs of wear, blistering, or any other signs of potential failure - replace if signs of potential failure are identified.
13. Inspect the gear train housing. If the amount of grease is inadequate, liberally grease the gear train through the access panel, and through the opening in the rotary gear.
Inspect top and bottom brake band linings - replace if necessary. Unequal wear of the brake bands indicates that the brake band tension is not evenly adjusted. Refer to the maintenance section of the manual for instructions on properly adjusting brake bands. Ensure that all grease is wiped from brake band linings and the parts of the cage plates that come into contact with the brake band linings
14. Re-install access panel. Install a set of pre-inspected jaws that are the correct size for the pipe or casing being run.
15. Install load cell. If using a tension load cell, perform a visual inspection and replace any cracked, broken, or distorted components including links and chains. If using a compression load cell, replace any component that has been crushed or otherwise distorted through compression.
16. If applicable, inspect the load cell anchor pins (tension load cell only). Replace the anchor pins if cracking or metal distortion is seen.
If applicable, the weld securing the single load cell anchor to the bridge bar main plate must be inspected (compression load cell only). If the integrity of the weld has been compromised, the tong must be removed from service until the weld is repaired. The load cell beam will need to be disconnected and removed so the weld is visible. Before re-installing the beam, liberally grease the anchor pin before reinserting into the load cell beam.
17. Re-energize power unit.

20. Perform a full functional test of the equipment including, if applicable, backup components and float frame components. Report and correct any hydraulic leaks from the hydraulic valve bank, or from any hydraulic cylinders that are used.
21. If using a frame-mounted tong and backup system, raise the tong off the beams that it is resting upon. Remove the beams and protective cloths - inspect the paint on top of the backup and the bottom of the tong to ensure it has not been damaged by the beam.
22. Test safety door feature (if equipped). Open the tong door(s), and attempt to rotate the cage plate at low speed (low gear) in both directions (makeup and breakout). If cage plate begins rotating, the safety door mechanism is not functional, and the tong must be removed from service until the safety door mechanism can be repaired. If the safety door is operating correctly, cage plate rotation will not be inhibited once the door is closed and latched.



NEVER OPERATE YOUR EQUIPMENT WITH A BYPASSED OR MALFUNCTIONING SAFETY DOOR

23. While rotating the cage plate, ensure that the jaws properly cam. If the jaws do not cam properly, the brake bands need to be tightened. Incrementally adjust both the top and bottom brake bands EQUALLY until proper cam action is achieved.
24. When all of the previous steps are completed, you may return your re-commissioned equipment to service.

Adequate maintenance and proper fluid selection is essential for minimizing hydraulic-related failures. All troubleshooting must be performed by a technician trained in hydraulic systems, and familiar with the equipment design, assembly and operation.

The following troubleshooting instructions are intended to be guidelines only. Any faults not solved through the use of this guide should be referred to our engineering department for their evaluation and recommendations.

A. TONG WILL NOT DEVELOP SUFFICIENT TORQUE

	POSSIBLE PROBLEM	SOLUTION(S)
1	Malfunctioning relief valve on tong hydraulic circuit	See Section 4.B, Relief Valve Troubleshooting
2	Directional valve is leaking	Check directional valve. Neutral position should return fluid directly to the reservoir. Replace or repair valve to ensure correct operation
3	Power unit is not producing adequate pressure	Troubleshoot power unit (see user's manual for your particular unit)
4	Poor hydraulic pressure at the tong despite adequate pressure at the power unit, or excessive back pressure in the return line.	Restrictions exist in line between power unit and tong. Inspect integrity of self-sealing couplings to ensure they are allowing full fluid flow. Check to ensure no other restrictions exist (contaminated catch screens or filters, for example)
5	Fluid viscosity is not appropriate (too high or too low)	Ensure hydraulic fluid being used is the viscosity recommended by McCoy Drilling & Completions. Power unit pump may not prime if fluid is too heavy, and the hydraulic system will overheat if fluid is too light. Replace with proper viscosity fluid Hydraulic fluid viscosity is affected by environmental conditions. Ensure the fluid being used is suitable for high or low temperatures. Replace with proper viscosity fluid for the operating conditions if necessary
6	Worn or damaged tong motor causing slippage	Replace or repair worn or damaged motor
7	Damaged bearings or gears causing excessive drag	Replace or repair worn or damaged gears or bearings
8	Jaws slipping on pipe	Ensure jaw dies are not worn to the point that they cannot grip. Ensure the correct sized jaws are in use
9	Torque gauge is indicating incorrectly	Incorrect gauge is being used. Ensure gauge is the proper range, and has been properly calibrated for the arm length of the equipment in use Gauge has been damaged. Check gauge operation and calibration on independent system Gauge has mistakenly been married to an incorrect load cell
10	Load cell is measuring incorrectly	Incorrect load cell is being used Air is trapped in torque measuring circuit (load cell, hydraulic line, or gauge. Refer to torque measurement troubleshooting in Section 6 of this manual Load cell has been damaged. Replace load cell, or return to McCoy for repair and re-calibration



MCCOY DRILLING & COMPLETIONS GUARANTEES CALIBRATION OF A LOAD CELL/TORQUE GAUGE ASSEMBLY FOR A PERIOD OF ONE YEAR. MCCOY SUGGESTS THAT THE LOAD CELL/TORQUE GAUGE ASSEMBLY BE RETURNED TO THE FACTORY FOR RE-CALIBRATION ON A YEARLY BASIS.

	POSSIBLE PROBLEM	SOLUTION(S)
11	Incorrect motor speed selected (applies to 2-speed motors only)	Maximum torque can only be developed when LOW motor speed (maximum hydraulic displacement) is selected.
12	Incorrect tong gear selected	Maximum torque can only be developed when LOW motor gear is selected

B. RELIEF VALVE IS INCORRECTLY SET OR NOT FUNCTIONING

	POSSIBLE PROBLEM	SOLUTION(S)
1	Relief pressure set too low, resulting in insufficient tong torque Relief pressure set too high, resulting in crushed pipe or gear train failure	Adjust setting (See following procedure):

- a. If your tong is equipped with a system pressure indicator proceed to step "f". If your tong does not have a system pressure indicator, a temporary 0 - 3000 PSI indicator must be installed on the hydraulic inlet.
- b. Isolate your tong from hydraulic power, and depressurize following the procedure in section 3.D.
- c. Tee in a temporary indicator at the safety door supply pressure port. Ensure all hydraulic connections are performed by a qualified hydraulic technician.

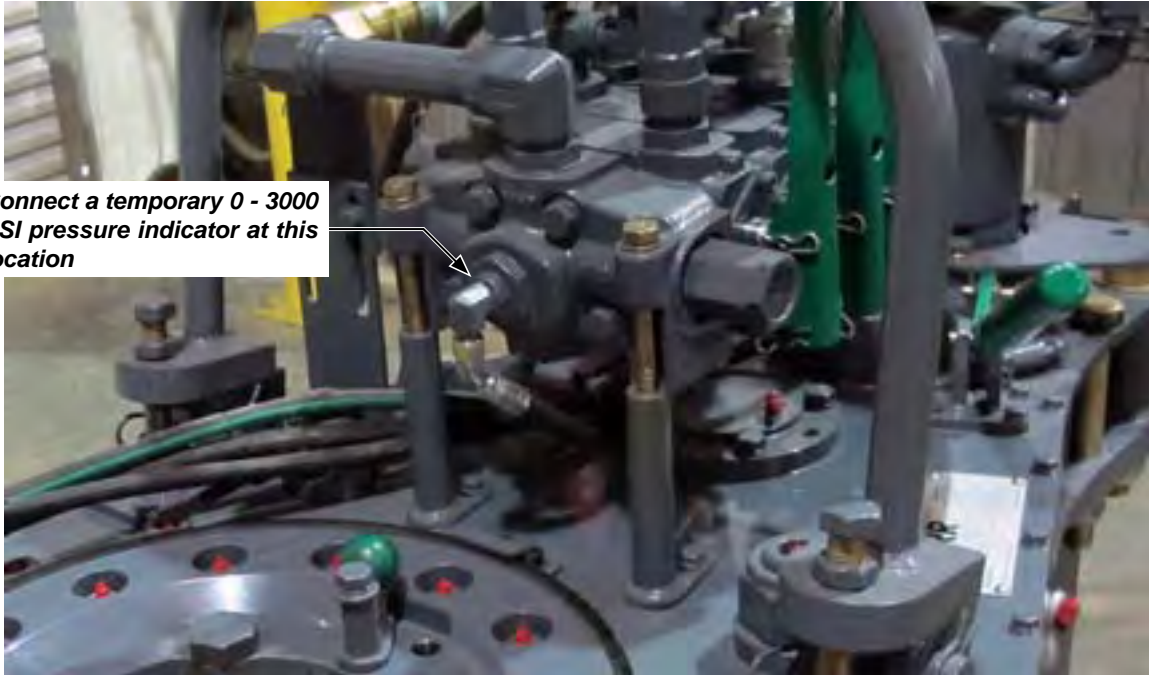

ILLUSTRATION 4.B.1: RELIEF VALVE TROUBLESHOOTING - TEMPORARY GAUGE INSTALLATION

- d. Re-establish hydraulic power to your tong. Ensure that no equipment functions are active.
- e. Loosen the locking nut on the pressure relief valve.
- f. Open the tong door to activate the safety door system and inhibit tong rotation.
- g. Activate motor control valve. Observe the pressure displayed on the pressure indicator. Adjust the relief valve until the pressure indicated is at the maximum system pressure specified on the specifications page (maximum system pressure is the pressure at which your tong achieves its specified torque).



DO NOT ADJUST PRESSURE RELIEF TO A SETTING THAT ALLOWS HIGHER THAN MAXIMUM SYSTEM PRESSURE. DOING SO CREATES A POTENTIAL FOR SERIOUS INJURY OR DEATH, AND MAY CAUSE CATASTROPHIC EQUIPMENT FAILURE.

- h. Release the motor control valve and tighten the locking nut on the pressure relief valve.
- i. Isolate your tong from hydraulic power, and depressurize following the procedure in section 3.D.
- j. Close the tong door, and remove the temporary pressure indicator. Restore the safety door pressure supply line to factory specifications. Verify that safety door is operating correctly (see section 2.1.5.k).

Continued on next page

RELIEF VALVE IS INCORRECTLY SET OR NOT FUNCTIONING Cont'd:

	POSSIBLE PROBLEM	SOLUTION(S)
2	<i>Relief cannot be adjusted to maximum system pressure (high fluid bypass results in low system pressure)</i>	<i>Debris on valve seat</i>
		<i>Valve spring is broken</i>
		<i>Valve spring has lost spring force due to continuous tension</i>

PROCEDURE:

- a. *Isolate your tong from hydraulic power, and depressurize following the procedure in section 3.D*
- b. *Loosen the locking nut on the pressure relief valve.*
- c. *Use a large flat-head screwdriver to completely un-thread the poppet and spring from the relief assembly.*
- d. *Inspect the relief valve spring, poppet, and valve seat.*
- e. *If no debris is found in relief valve and if seat and poppet are undamaged, replace relief valve spring.*
- f. *Reassemble relief valve.*
- g. *Relief valve must be re-set to allow maximum system pressure. Follow the procedure in Step 1 of this section to properly adjust relief valve.*
- h. *If maximum system pressure still cannot be reached, replace the entire relief valve assembly.*

C. SAFETY DOOR DOES NOT OPERATE OR IS MALFUNCTIONING

	POSSIBLE PROBLEM	SOLUTION(S)
1	<i>Safety door switch requires adjustment.</i>	<i>Adjust switch as per section 3.F.5</i>
2	<i>Safety door switch has failed</i>	<i>Test safety door switch for proper function and replace if necessary</i>
3	<i>Contamination in hydraulic lines</i>	<i>Ensure all three flexible hydraulic lines to safety door switch are free-flowing</i>
4	<i>Pilot-to-open valve in safety door valve block is malfunctioning.</i>	<i>Remove each valve. Inspect seats and springs. Replace valve(s) if damage is seen on valve seats, or if spring appears to be damaged or broken.</i>

D. TONG RUNNING TOO SLOWLY

	POSSIBLE PROBLEM	SOLUTION(S)
1	Obstruction in tong hydraulic circuit preventing adequate flow	Inspect self-sealing couplings to ensure they are properly engaged The main hydraulic lines (supply and discharge) to the tong are obstructed. Remove and clean if required
2	Power unit is not producing adequate flow or pressure	Troubleshoot power unit (see user's manual for your particular unit)
3	Tong motor is excessively worn and is leaking hydraulic fluid past the vanes	Replace motor, or rebuild as per Section 7 of this manual
4	Bearings in gear train and rotary section are excessively worn	Overhaul tong. See Section 3 of this manual for tong overhaul procedures
5	Shifter has malfunctioned and the tong is not shifting to high gear	Inspect and repair shift mechanism as necessary
6	Hydraulic fluid viscosity too high	Ensure hydraulic fluid meets McCoy Drilling & Completions specifications Ensure hydraulic fluid is appropriate for climatic conditions, especially during cold-weather operation
7	By-pass valve not functioning	Check and repair

E. FAILURE OF JAWS TO GRIP PIPE

	POSSIBLE PROBLEM	SOLUTION(S)
1	<i>Dies have become too dull to provide adequate grip</i>	<i>Replace dies</i>
2	<i>Incorrect jaws are being used</i>	<i>Double-check jaw size to ensure they are rated for the diameter of pipe or casing being run</i>
3	<i>Incorrect dies are being used</i>	<i>Ensure dies loaded in the jaws are appropriate for the type of pipe or casing being run</i>
4	<i>Brake band(s) is (are) insufficiently adjusted, not allowing jaws to cam properly</i>	<i>Adjust brake bands to give proper resistance to cage plates</i>
5	<i>Jaw roller broken or worn</i>	<i>Remove jaw assembly and inspect. Replace rollers that are visibly "flat-spotted" or otherwise damaged</i>

F. FAILURE OR DIFFICULTY OF TONG TO SHIFT

	POSSIBLE PROBLEM	SOLUTION(S)
1	<i>Bent or broken shifter handle</i>	<i>Replace shifter handle</i>
2	<i>"Frozen" or hard-to-move shifter handle</i>	<i>Grease shifter shaft</i>
3	<i>Bent or broken shifter yoke</i>	<i>Inspect components through inspection door. Replace shifter yoke if necessary.</i>
4	<i>Bent or broken shifter shaft</i>	<i>Replace</i>
5	<i>Locking nuts on shifting shaft have loosened and position of yoke has changed</i>	<i>Reposition yoke and re-tighten locking nuts</i>
6	<i>Shifting yoke has come loose from shifting shaft</i>	<i>Inspect yoke and inspect for damage. If free of damage, replace on shaft and tighten locking nuts</i>
7	<i>Tong pops out of gear</i>	<i>Ensure that detent ball & spring assembly has been correctly set</i>

G. GENERAL COMMENTS

The following factors generally contribute to poor hydraulic operation and premature wear of equipment:

1. Contaminated hydraulic fluid due to overuse, overheating, or inadequate fluid filtration.
2. Unsuitable hydraulic fluid, especially in extreme climatic conditions.
3. Defective packing or seals in components of the hydraulic system.
4. Poor or incomplete hydraulic system training. Users must be fully qualified to operate the equipment, and have complete understanding of the hydraulic system.

If your hydraulic troubleshooting procedures involve flow and pressure tests at the power unit, McCoy Completions & Drilling recommends construction of a test rig that can easily be connected to the main suction and discharge ports of the power unit.

Assemblies and Parts



Model 80-0935-4 Shown



Model 80-0935-4 (CE Marked) Shown

The following table lists parts that McCoy Drilling & Completions | FARR has identified as critical spare parts for this model of tong. McCoy recommends that the specified quantity of each part be on hand at all times.

MISC TONG & BACKUP PARTS		
Description	Part Number	Qty. Required
Motor Gear	997-A10-149	1
Jaw Pivot Bolt	997-D3-28	2
Cage Plate Spacer	997-38B	3
Backing Pin	101-4142	1
Lined Brake Band Weldment	997-D23-29	1
Rigid Sling Pins	1053-C-1C	2
Upper Guide Ring (KT13625)	997-HT-23-TOP	1
Lower Guide Ring (KT13625)	997-HT-23-BOT	1
Safety Door Latch Claw - RH	AE13-302M	1
Safety Door Latch Claw - LH	AE13-301S	1
Safety Door Load Plunger	AE12-306	1
Door Spring Stop Cylinder	101-0069	1
Door Latch Spring	997-16	2
Dumbbell Roller Cup	997-D21-135	4
Dumbbell Roller Sleeve	997-D21-134	2
BEARINGS & BUSHINGS		
Description	Part Number	Qty. Required
Dumbbell Roller Bearing	02-0014	4
Bottom Clutch Roller Bearing	02-0014	1
Cam Follower (LW13625)	02-0016	5
Pinion Bearing	1234-08-01B	2
FASTENERS & FITTINGS		
Description	Part Number	Qty. Required
External Snap Ring Clutch Drive Gear Retainer	1234-00-04	2
Motor Gear Set Screw	09-0106	1
Motor Gear Key	01-0317	1
Hex Bolt 1/2" UNC X 7" (Cage Plate Bolt)	09-1194	3
5/8" Lock Washer (Cam Follower Fastener - LW13625)	09-5114	5
5/8" UNF Jam Nut (Cam Follower Fastener - LW13625)	09-5514	5
3/8 UNC X .5" Flange Bolt (Jaw Die Retainer)	09-0229	10
5/16 UNC X .5" Countersunk (Jaw Die Retainer)	09-1338	10
5/32" x 2-15/16" Hitch Pin	02-0981	4
BEARINGS & BUSHINGS		
Description	Part Number	Qty. Required
Dumbbell Roller Bearing	02-0014	4
Bottom Clutch Roller Bearing	02-0014	1
Cam Follower (LW13625)	02-0016	5
Pinion Bearing	1234-08-01B	2

ITEMS ON THE CRITICAL SPARE PARTS LIST MARKED IN RED INDICATE ESSENTIAL HEALTH & SAFETY ITEMS. FAILURE TO REPLACE DAMAGED ESSENTIAL HEALTH & SAFETY ITEMS WILL PRESENT IMMEDIATE DANGER TO PERSONNEL OR EQUIPMENT. HAVE THESE ITEMS ON HAND AT ALL TIMES. STOP WORK AND QUARANTINE TONG UPON DISCOVERY OF DAMAGED OR DEFECTIVE HEALTH AND SAFETY COMPONENTS UNTIL PARTS CAN BE REPLACED.

Critical Spare Parts Continued		
HYDRAULIC COMPONENTS		
Description	Part Number	Qty. Required
Relief Cartridge (DVA35)	10-0010R	1
Relief Cartridge (Safety Door)	08-1625	1
Safety Door Switch	08-0337M	1
Hydraulic Hose - Lift Cylinder Supply (If lift cylinder is installed)	02-0934H	1
High-Visibility Protective Wrap, Lift Cylinder Hose (If lift cylinder is installed)	02-E0203	1
Hydraulic Hose Assembly - Backup 55" "A" Side	02-1011	1
Hydraulic Hose Assembly - Backup 52" "B" Side	02-1012	1
High-Visibility Protective Wrap, Backup Hydraulic Hose	02-E0204	1
JAW COMPONENTS		
Description	Part Number	Qty. Required
Jaw Roller	997-JR-2125	2
Jaw Pin	101-1581	2
Jaw Roller (Applies only to sizes 12-3/4" to 13-5/8")	997-JR-1000	2
Jaw Roller Keeper (Applies only to sizes 12-3/4" to 13-5/8")	101-0491	2
3.875" Flat Die Insert	13-0008-314-0	48
Wraparound Insert (3-1/2" jaw die kits only)	12-2006	4
Wraparound Insert (4" jaw die kits only)	12-2007	4
Wraparound Insert (4-1/2" wraparound jaw die kits only)	12-2009	4

In addition to the critical spare parts identified earlier, McCoy suggests stocking the following spare parts. Even though these are not critical spares, stocking these components may significantly decrease repair time in the event of long lead times from the factory.

MISC TONG PARTS		
Description	Part Number	Qty. Recommended
Backing Pin Spacer	101-4096	1
Backing Pin Stud	101-4097	1
Backing Pin Knob	02-0017	1
Shifting Yoke	997-HT-72	1
Shifting Shaft	997-B1-71	1
Door Spring Cylinder	101-0069	1
Brake Band Retainer	101-0140	2
Lined Brake Band Weldment	997-D23-29	2
BEARINGS & BUSHINGS		
Description	Part Number	Qty. Recommended
Door Bushing (Top)	101-5110	2
Door Bushing (Bottom)	101-5111	2
FASTENERS & FITTINGS		
Description	Part Number	Qty. Recommended
Shifter Detent Force Spring	997-0-64	1
Shifter Detent Force Ball	02-0018	1
1/8" NPT Grease Fitting	02-0005	2
1/8" NPT 90° Grease Fitting	02-0093	2
1/8" NPT 45° Grease Fittings	02-0006	2
1/4" Straight Thread Grease Fitting	02-0097	5
3/8 UNC X .5" Flange Bolt (Jaw Retainer)	09-0229	10
5/16 UNC X .5" Countersunk (Jaw Retainer)	09-1338	10

The following tables list parts McCoy Drilling & Completions recommends replacing when performing a complete overhaul of your tong and backup assembly.

MISC TONG PARTS		
Description	Part Number	Qty. Required
Jaw Pivot Bolt	997-D3-28	2
Backing Pin	101-4142	1
Backing Pin Short Spacer	101-4096	1
Backing Pin Long Spacer	101-4093	1
Backing Pin Stud	101-4097	1
Backing Pin Knob	02-0017	1
Backing Pin Retainer	101-4139	1
Cage Plate Spacer	997-38B	3
Lined Brake Band Weldment	997-D23-29	2
Brake Band Retainers	101-0140	2
Door Spring Stop Cylinder	101-0069	2
Door Cylinder Post	1050-12-001	2
Door Latch Springs	997-16	2
Safety Door Latch Claw (RH)	AE13-302M	1
Safety Door Latch Claw (LH)	AE13-301S	1
Safety Door Load Plunger	AE12-306	1
Shifting Shaft	997-B1-71	1
Shifting Yoke	997-HT-72	1
Top Shifter Bushing	101-0020	1
Dumbbell Roller Cup	997-D21-135	28
Dumbbell Roller Sleeve	997-D21-134	14
Roller Spacer	997-D21-140	28
Roller Shaft	101-1266	10
Roller Shaft (Long)	101-1268	2
Door Pivot Roller Shaft	101-0046	2
Drive Gear (Clutch)	997-HT-61	1
Shifting Collar	997-HT-62	1
High Clutch Gear	997-HT-51B	1
Splined Clutch Shaft	997-HT-50	1
Low Clutch Gear	997-HT-52	1
Motor Gear	997-A10-149	1
BEARINGS & BUSHINGS		
Description	Part Number	Qty. Required
Dumbbell Roller Bearings	02-0014	28
Idler Bearing	02-0075	4
Pinion Bearing	1234-08-01B	2
Ball Bearing (Bottom Clutch Bearing)	02-0014	1
Needle Bearing (Clutch Shaft)	02-1404	4
Ball Bearing (Top Clutch Bearing)	02-1403	1
Cam Follower (LW13625)	02-0016	22
Door Bushing (Top)	101-5110	2
Door Bushing (Bottom)	101-5111	2

FASTENERS & FITTINGS		
Description	Part Number	Qty. Required
Idler Seal	02-0010	6
Idler Retainer	02-0009	8
1/4" Straight Thread Grease Fitting	02-0097	16
1/8" NPT Grease Fitting	02-0005	5
1/8" NPT 90° Grease Fitting	02-0093	7
Snap Ring (Clutch Shaft)	1234-00-04	1
Motor Gear Set Screw	09-0106	2
Motor Key	01-0317	1
7/8" Narrow Flat Washer (Support Roller Washer)	09-5123	18
7/8" UNF Thin Nylock Nut (Support Roller Fastener)	09-5722	12
3/4" UNF Thin Nylock Nut (Door Pivot Support Roller Fastener)	09-5718	2
Hex Bolt 1/2" UNC X 7" (Cage Plate Bolt)	09-1194	2
Hex Bolt 1/2" UNC X 9" (Backing Pin Bolt)	09-1202	1
5/8" Lock Washer (Cam Follower Fastener, LW13625)	09-5114	26
5/8" UNF Jam Nut (Cam Follower Fastener, LW13625)	09-5514	26
Shifter Detent Force Spring	997-0-64	1
Shifter Detent Force Ball	02-0018	1
HYDRAULIC COMPONENTS		
Description	Part Number	Qty. Required
Safety Door Switch	08-0337M	1
DVA35 Seal Kit	07-0004	1
Relief Cartridge (DVA35)	10-0010R	1
Relief Cartridge (Safety Door)	08-1625	2
Rineer GA15 Seal Kit	87-7110	1
Hydraulic Hose - Lift Cylinder Supply (If lift cylinder is installed)	02-0934H	1
High-Visibility Protective Wrap, Lift Cylinder Hose (If lift cylinder is installed)	02-E0203	1

ITEMS ON THE CRITICAL SPARE PARTS LIST MARKED IN **RED** INDICATE ESSENTIAL HEALTH & SAFETY ITEMS. FAILURE TO REPLACE DAMAGED ESSENTIAL HEALTH & SAFETY ITEMS WILL PRESENT IMMEDIATE DANGER TO PERSONNEL OR EQUIPMENT. HAVE THESE ITEMS ON HAND AT ALL TIMES. STOP WORK AND QUARANTINE TONG UPON DISCOVERY OF DAMAGED OR DEFECTIVE HEALTH AND SAFETY COMPONENTS UNTIL PARTS CAN BE REPLACED.

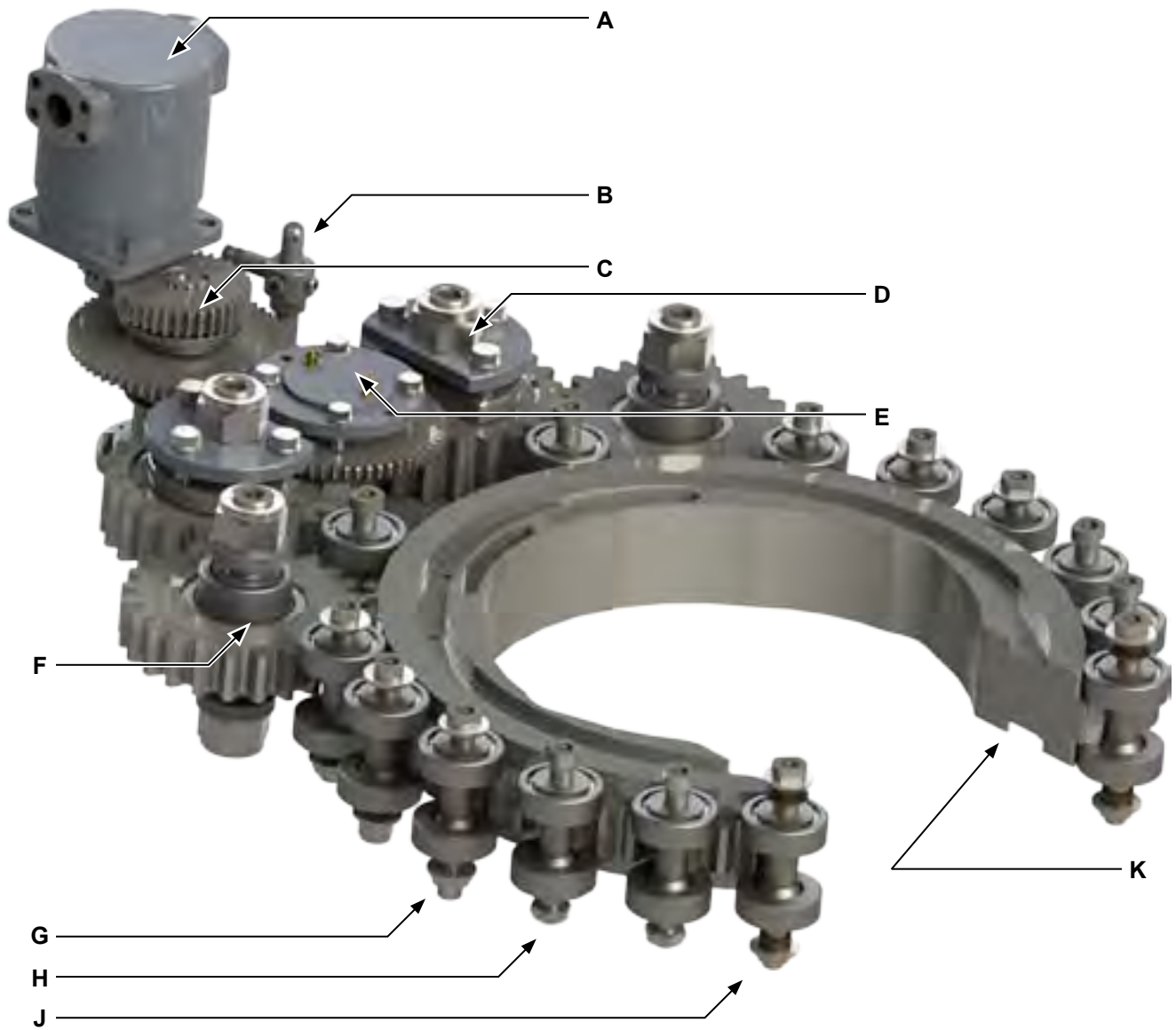

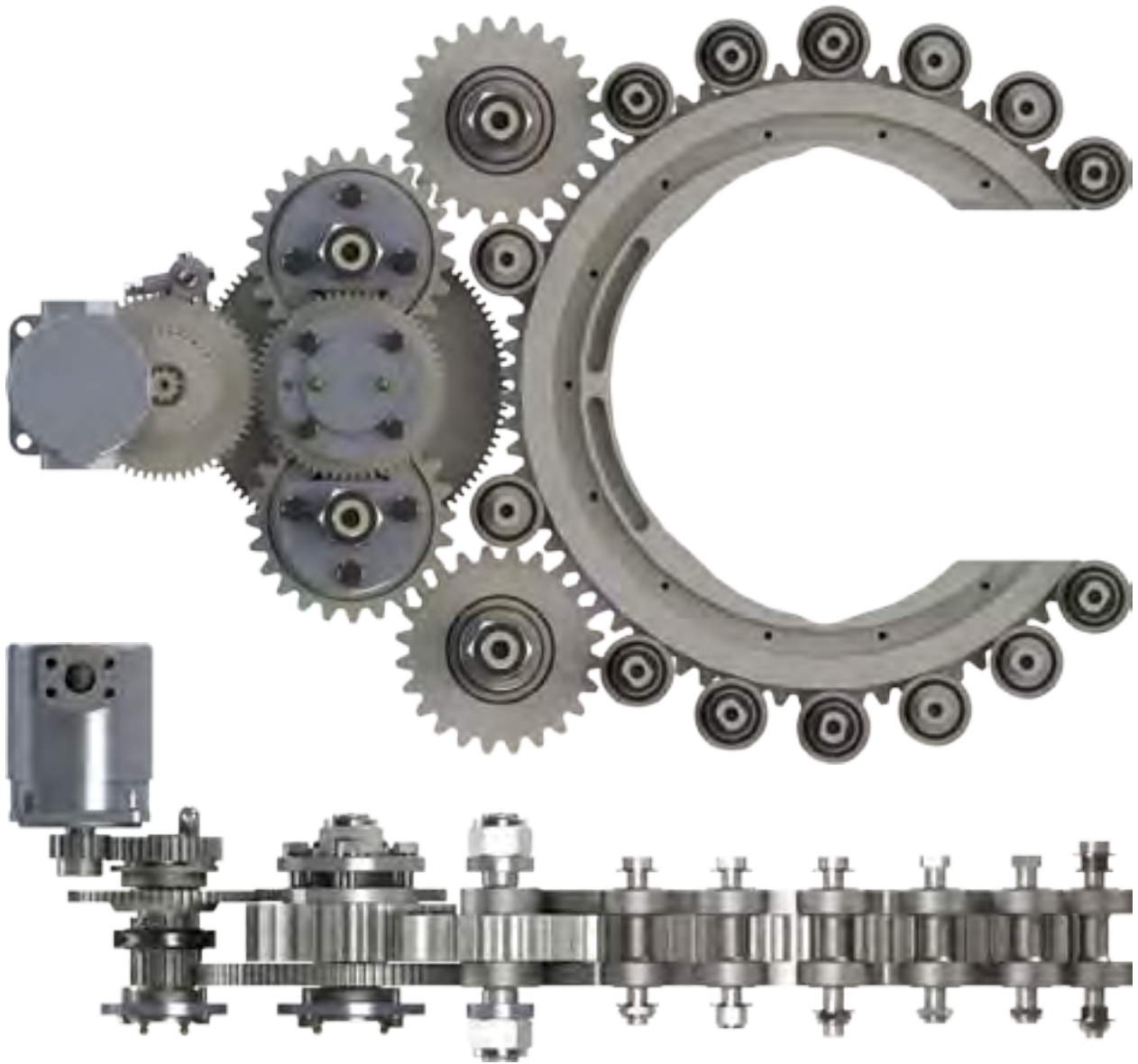

Item	Type	Description	Qty	Part Number
A	Part	Hydraulic Motor	1	87-0112
B	Assembly	Shifting Assembly (See Pp. 5.16 - 5.17)	1	
C	Assembly	Clutch Assembly (Pp 5.14 - 5.15)	1	
D	Assembly	Pinion Idler Assembly (Pp. 5.10 - 5.11)	2	
E	Assembly	Pinion Assembly (Pp 5.12 - 5.13)	1	
F	Assembly	Rotary Idler Assembly (Pp 5.8 - 5.9)	2	
G	Assembly	Support Roller Assembly, Front Leg Coincidental (Pp. 5.4 - 5.5)	4	
H	Assembly	Support Roller Assembly (Pp. 5.4 - 5.5)	8	
J	Assembly	Door Door Pivot Roller Assembly (Pp. 5.6 - 5.7)	2	
K	Part	Rotary Gear	1	997-D1-B

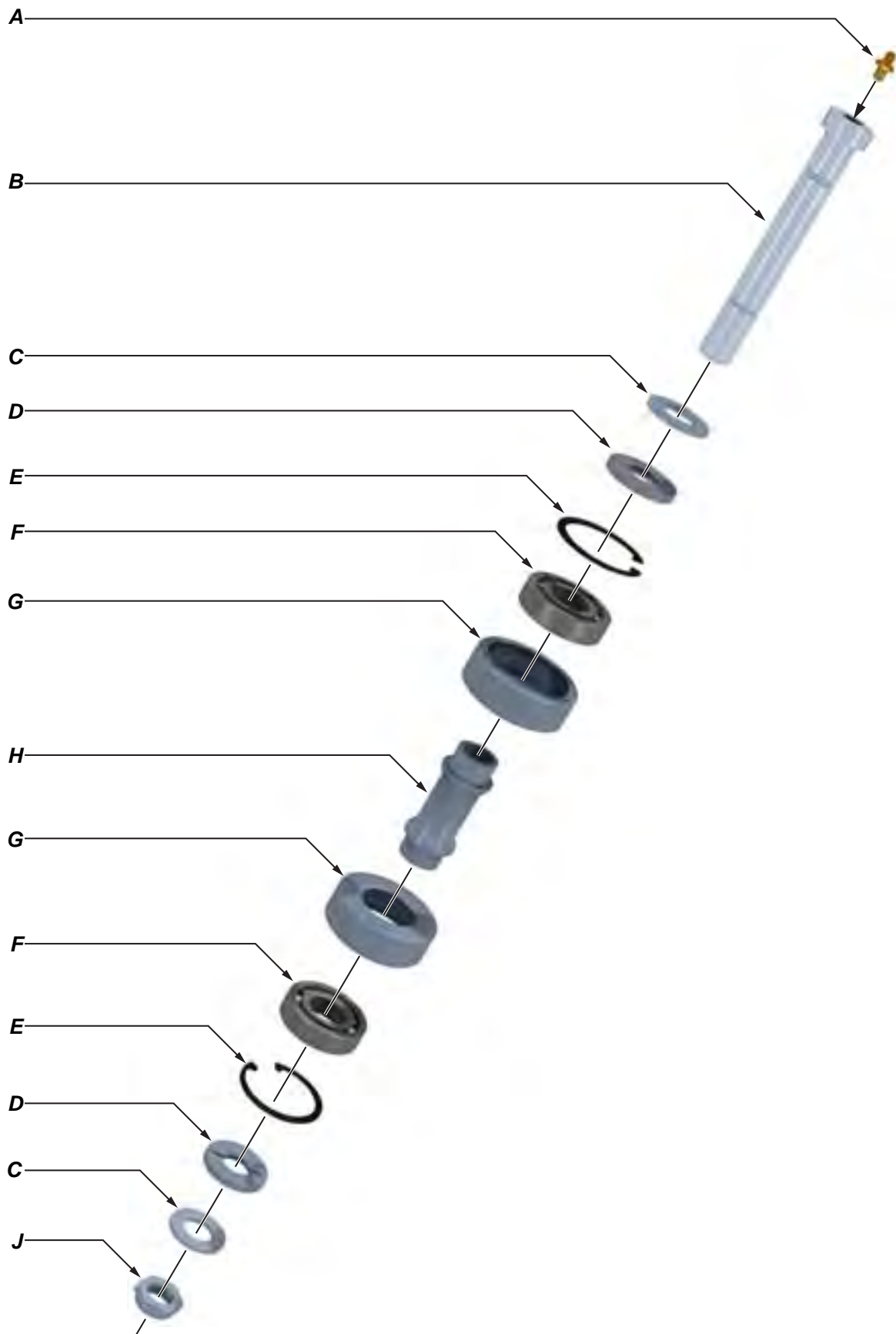



Item	Type	Description	Qty	Part Number
A	Part	1/4-24 UNF Grease Fitting	1	02-0097
B	Part	Support Roller Shaft (See Note A)	1	101-1266 / 101-1268
C	Part	7/8" Narrow Washer (See Note B)	2	09-5123
D	Part	Roller Cap Spacer	2	997-D21-140
E	Part	BS 3673 Metric B062M Retaining Ring	2	02-0013
F	Part	Cylindrical Roller Bearing (KT13625 Tongs)	2	02-0014
	Part	Ball Bearing Roller Bearing (LW13625 Tongs)	2	02-0101
G	Part	Roller Cup	2	997-D21-135
H	Part	Support Roller Sleeve	1	997-D21-134
J	Part	7/8" UNF Thin Hex Nylock Nut	1	09-5722

NOTE A: Where the support roller is coincidental with the front leg assembly, shaft number 101-1268 is used (4 occurrences).

NOTE B: Upper washers are not used where the support roller assembly is coincidental with the brake band retainer lug weldments and the hydraulic valve mount post weldments (6 occurrences).

Lower washers are not used where the support roller assembly is coincidental with the brake band retainer lug weldments and the front leg assemblies (8 occurrences - backup ready, or 6 occurrences - stand-alone tong).

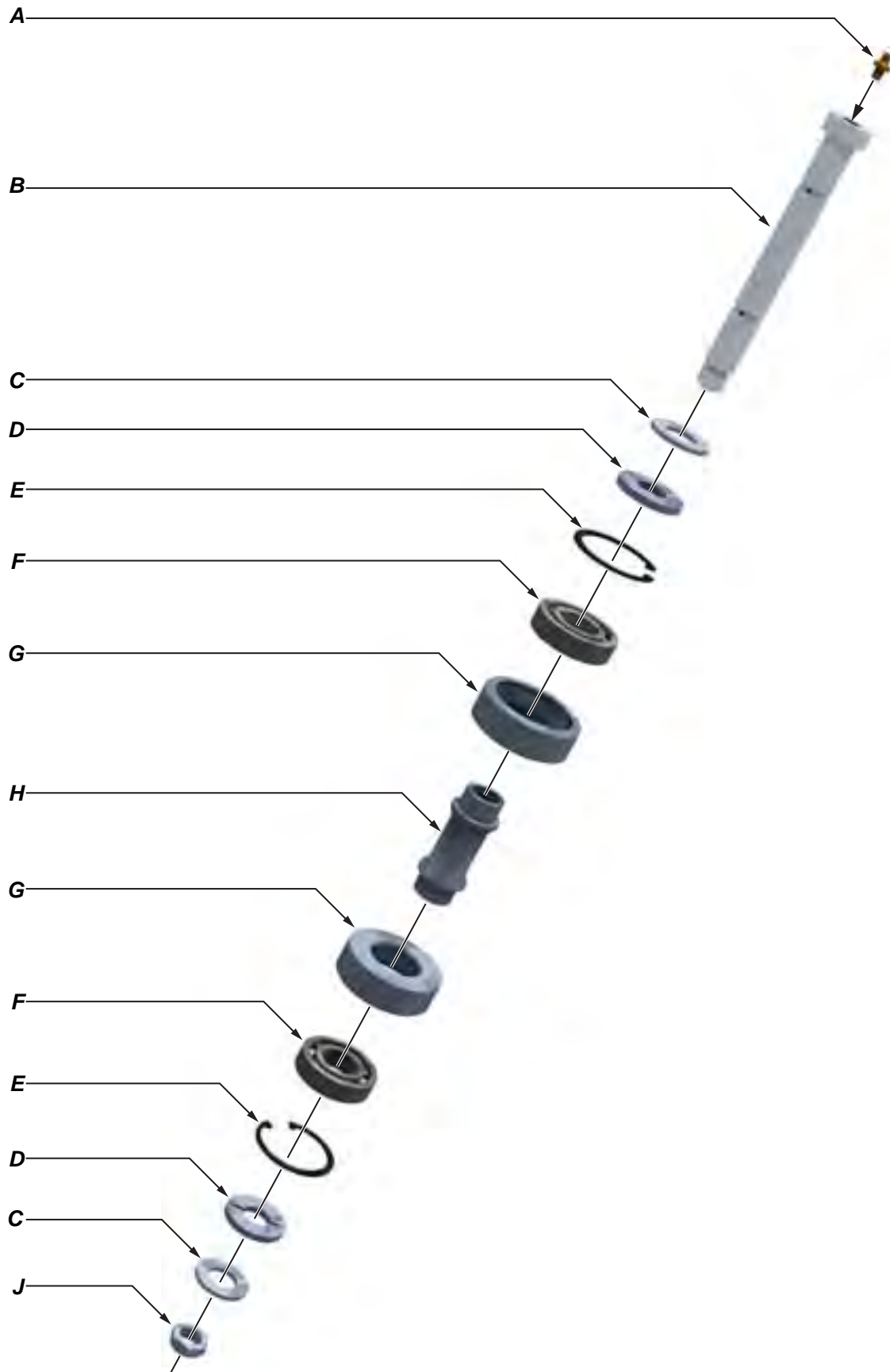



Item	Type	Description	Qty	Part Number
A	Part	1/4-24 NF Grease Fitting	1	02-0097
B	Part	Support Roller Shaft	1	101-0046
C	Part	7/8" Narrow Washer	2	09-5123
D	Part	Roller Cap Spacer	2	997-D21-140
E	Part	Metric B062M Inside Snap Ring	2	02-0013
F	Part	Cylindrical Roller Bearing (KT13625 Tongs)	2	02-0014
	Part	Ball Bearing Roller Bearing (LW13625 Tongs)	2	02-0101
G	Part	Roller Cup	2	997-D21-135
H	Part	Door Roller Sleeve	1	997-D21-134
J	Part	3/4" UNF Thin Hex Nylock Nut	1	09-5718

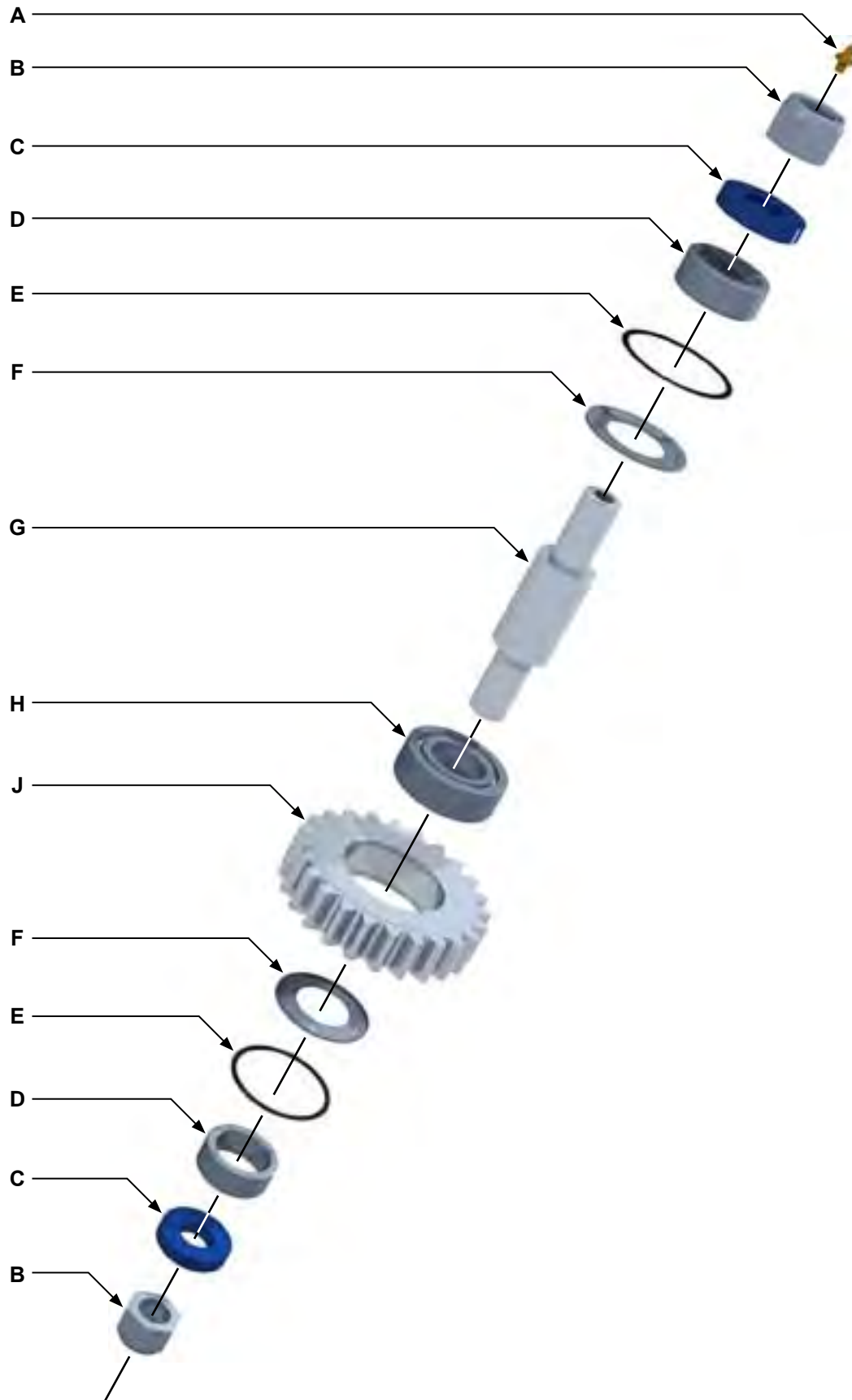



Item	Type	Description	Qty	Part Number
A	Part	Grease Fitting, 1/8" NPT	1	02-0005
B	Part	1-1/2" UNF Nylock Nut	2	02-5740
C	Part	Rotary Idler Pad	2	997-D20-125
D	Part	Idler Gear Bearing Spacer	2	997-D20-121
E	Part	Retainer Clip	2	02-0009
F	Part	Bearing Seal	2	02-0010
G	Part	Rotary Idler Shaft	1	997-D19-117
H	Part	Cylindrical Roller Bearing	1	02-0075
J	Part	Rotary Idler Gear	1	997-A2-119C

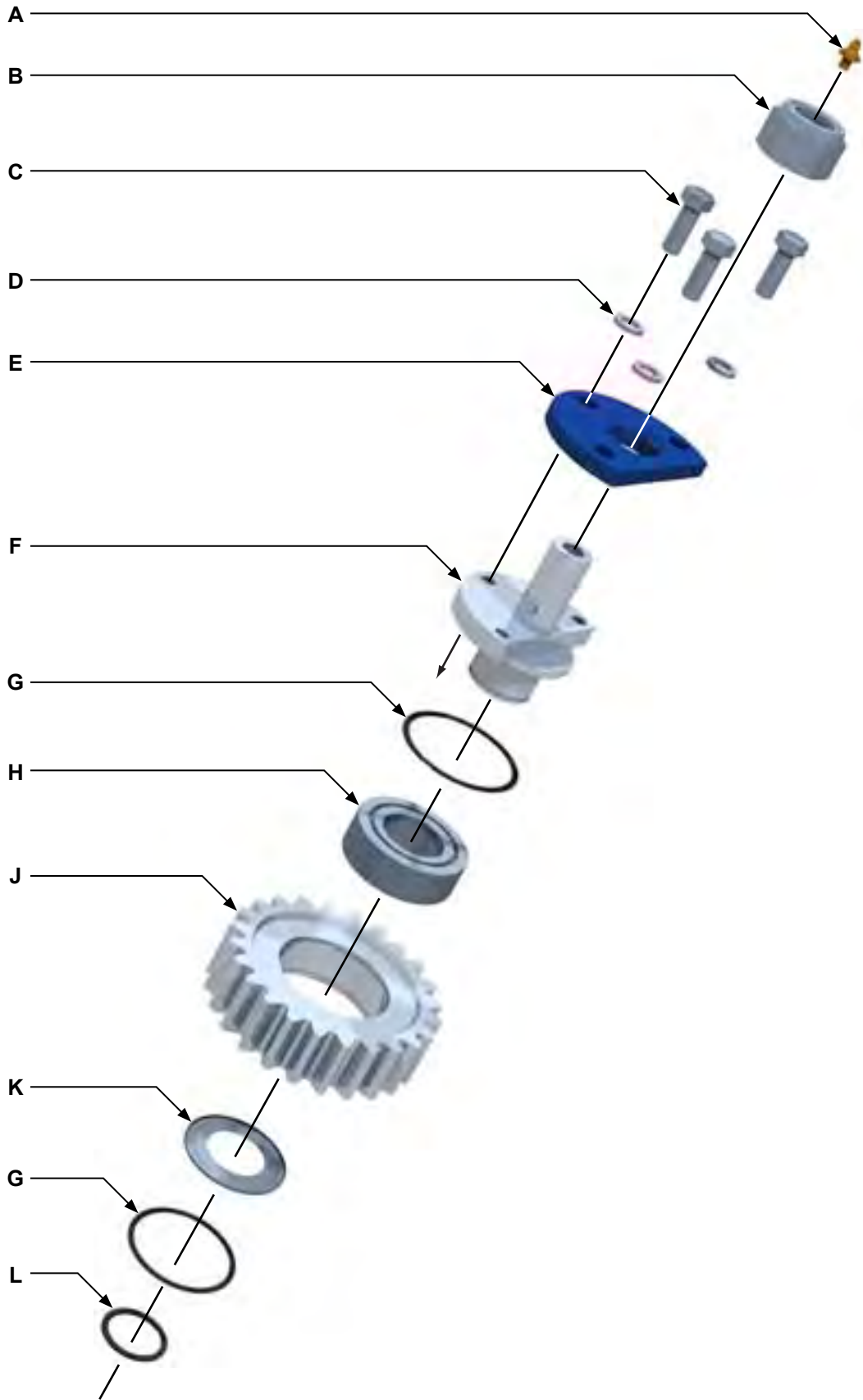



Item	Type	Description	Qty	Part Number
A	Part	Grease Fitting	1	02-0005
B	Part	1-1/2" UNF Nylock Nut	1	09-5740
C	Part	5/8" NC x 1-3/4" Hex Bolt	3	09-1232
D	Part	5/8" Lock Washer	3	09-5114
E	Part	Pinion Idler Pad	1	997-D17-109
F	Part	Pinion Idler Half Shaft	1	997-D17-105B
G	Part	Retainer Clip	2	02-0009
H	Part	Cylindrical Roller Bearing	1	02-0075
J	Part	Pinion Idler Gear	1	997-A2-119B
K	Part	Idler Bearing Retainer	1	02-0008
L	Part	Bearing Seal	1	02-0010

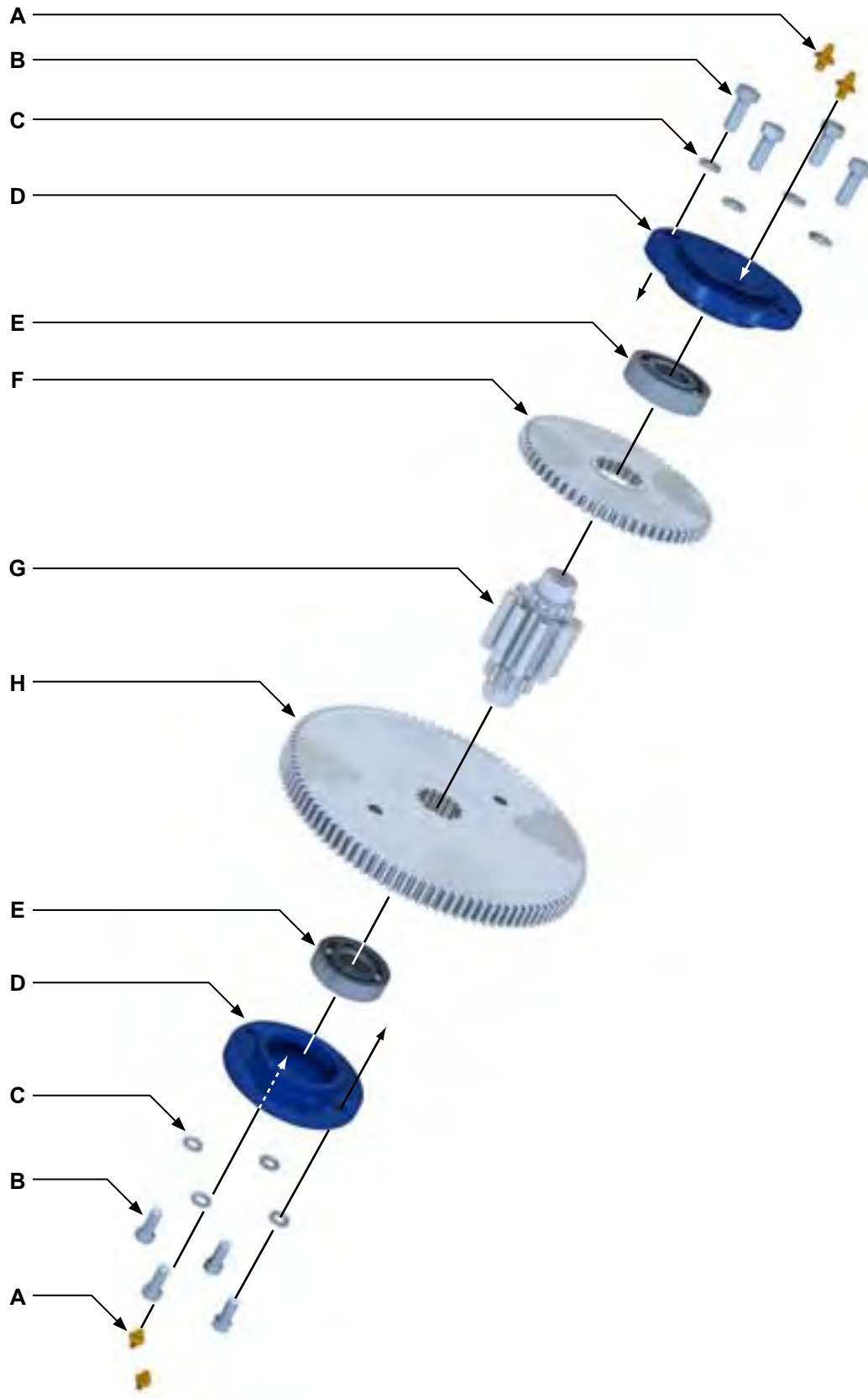

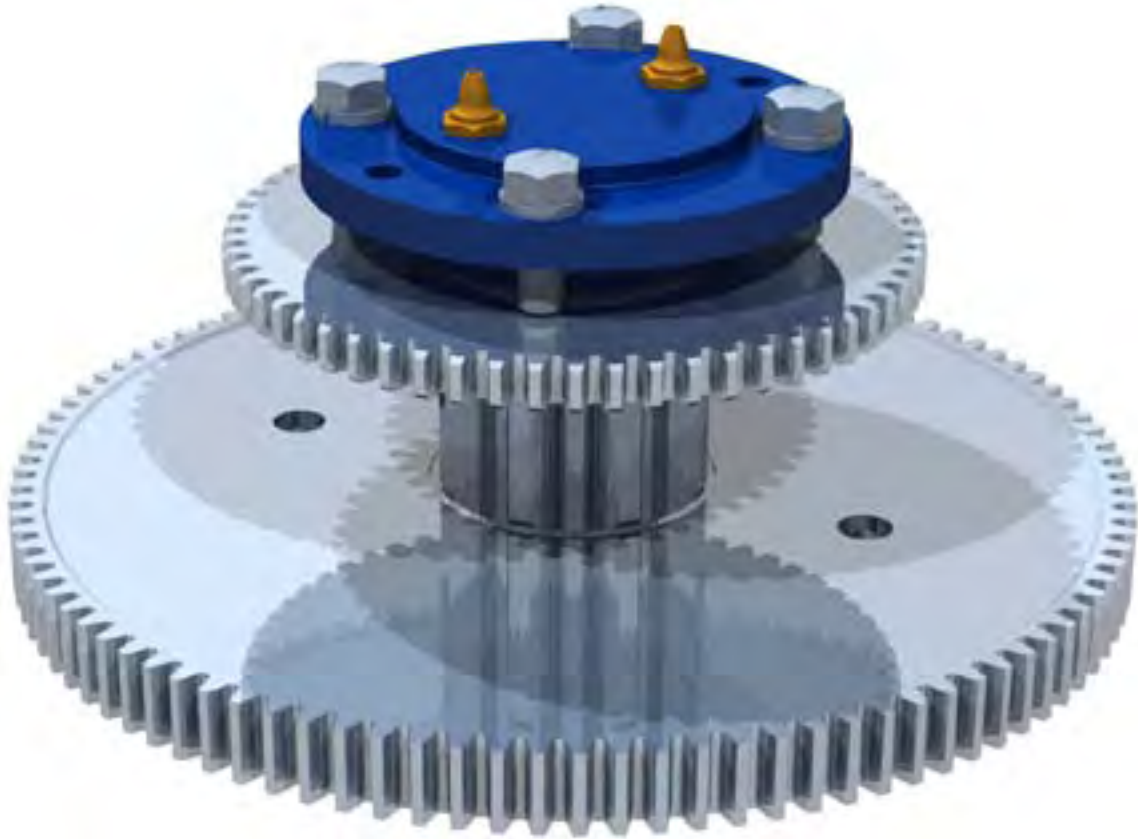

Item	Type	Description	Qty	Part Number
A	Part	1/8" NPT Grease Fitting	4	02-0005
B	Part	1/2" NC x 1-1/4" Hex Bolts	8	09-1168
C	Part	1/2" Lock Washers	8	09-5110
D	Part	Pinion Bearing Cap	2	997-D15-89
E	Part	Cylindrical Roller Bearing	2	1234-08-01B
F	Part	High Pinion Gear	1	997-A4-87B
G	Part	Pinion Gear Shaft	1	997-A7-86B
H	Part	Low Pinion Gear	1	997-A5-88

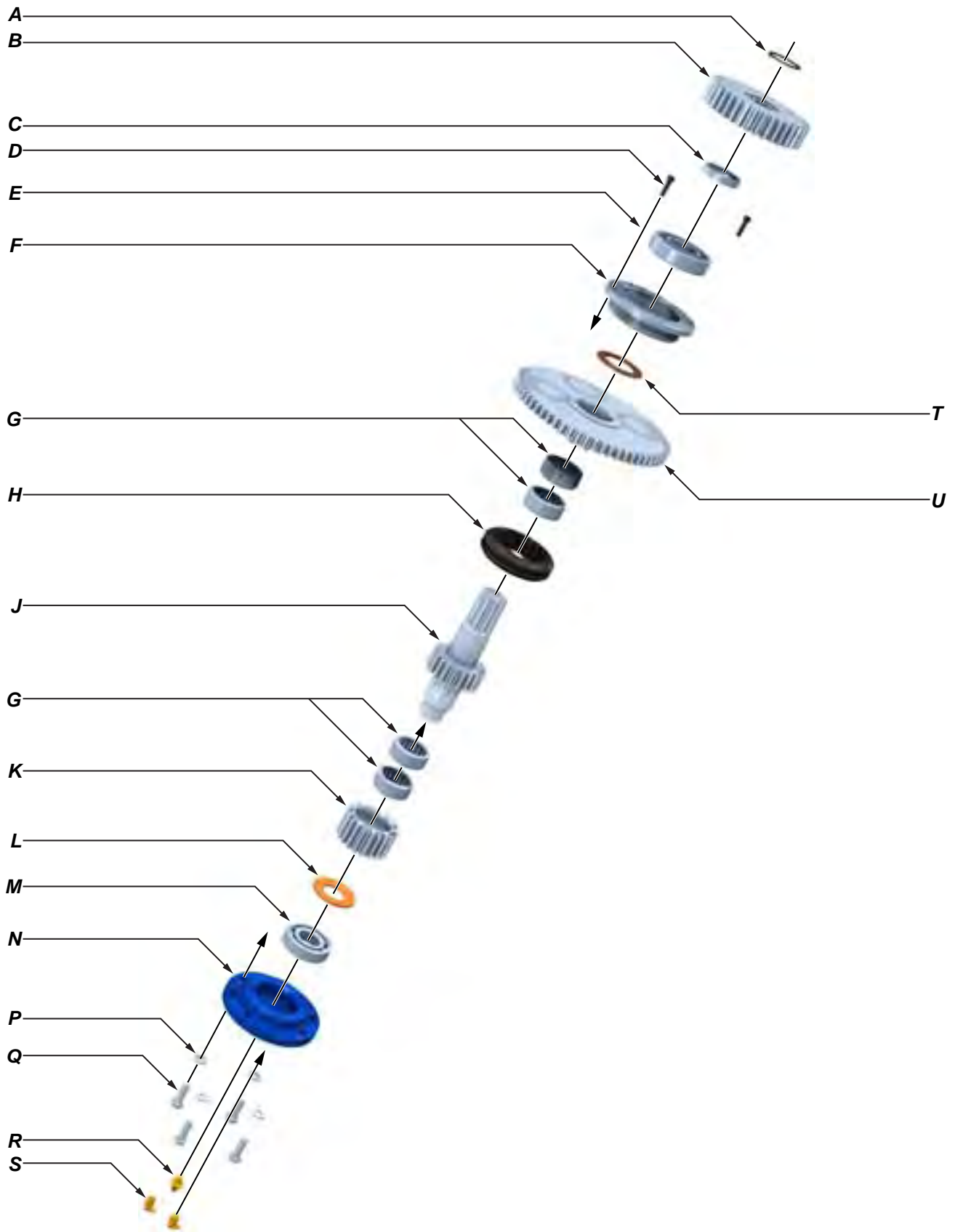



Item	Type	Description	Qty	Part Number
A	Part	Outside Snap Ring	1	1234-00-04
B	Part	Drive Gear	1	997-HT-61
C	Part	Clutch Bearing Bushing	1	997-HT-60
D	Part	#10-24 x 3/4" Hex Socket Head Cap Screw	2	09-0001
E	Part	Cylindrical Roller Bearing	1	02-1403
F	Part	Bearing Retainer	1	997-HT-59
G	Part	Needle Roller Bearing	4	02-1404
H	Part	Shifting Collar	1	997-HT-62
J	Part	Splined Clutch Shaft	1	997-HT-50
K	Part	Low Clutch Gear	1	997-HT-52
L	Part	Clutch Spacer	1	997-99
M	Part	Cylindrical Roller Bearing	1	02-0014
N	Part	Clutch Bearing Cap	1	997-HT-54
P	Part	3/8" Lock Washer	4	09-5106
Q	Part	3/8" NC x 1-1/4" Hex Bolt	4	09-1048
R	Part	1/8" NPT Grease Fitting	1	02-0005
S	Part	1/8" NPT 90 Deg. Grease Fitting	2	02-0093
T	Part	Clutch Spacer	1	101-3599
U	Part	High Clutch Gear	1	997-HT-51B

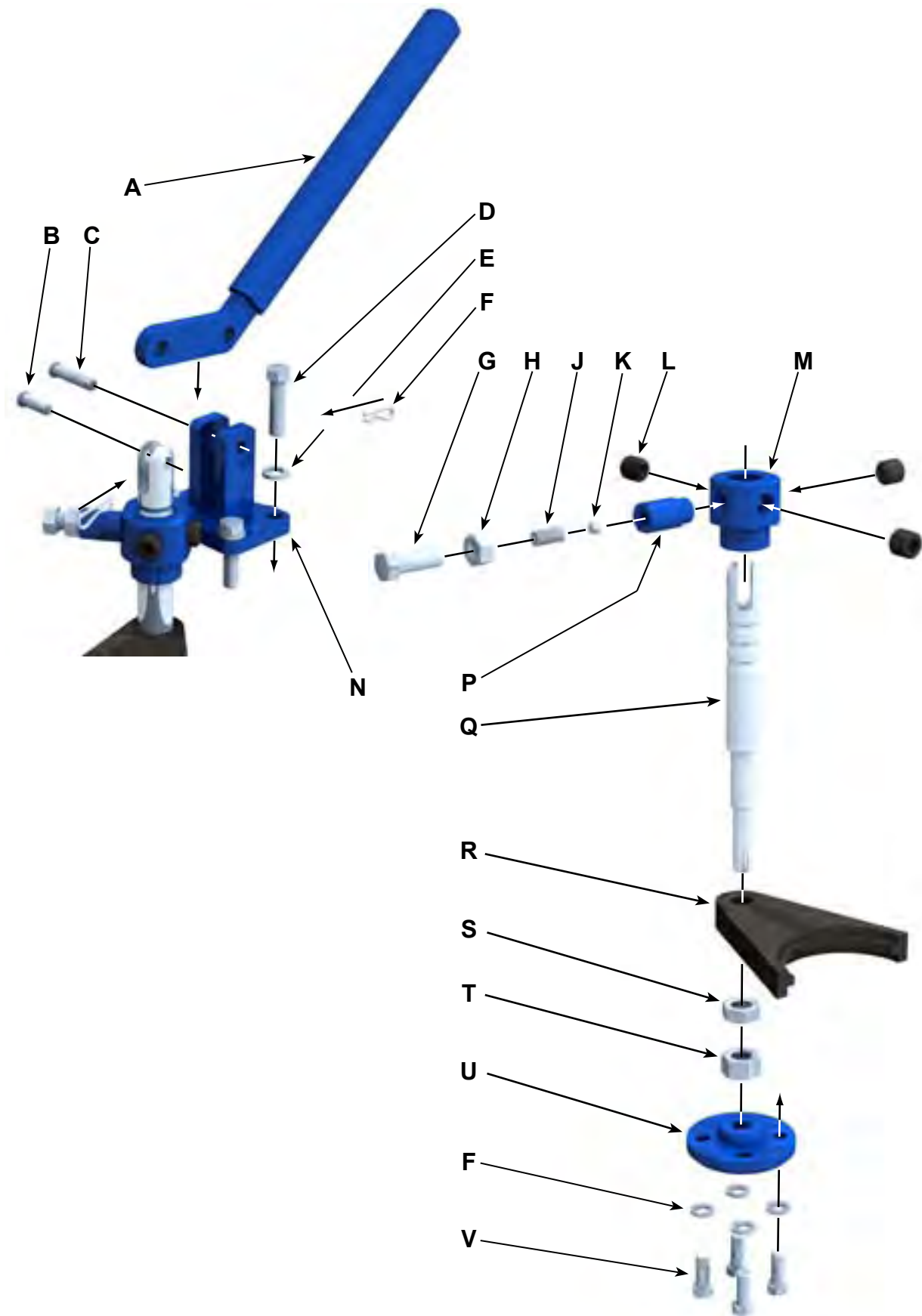



Item	Type	Description	Qty	Part Number
A	Part	Shifting Handle Weldment	1	1037-D-20B
B	Part	5/16" x 1" Clevis Pin	1	02-0020
C	Part	5/16" x 1-1/2" Clevis Pin	1	09-0256
D	Part	3/8" NC x 1-1/2" Hex Bolt	4	09-1553
E	Part	3/8" Lock Washer	8	09-5106
F	Part	HITCH PIN .0930 X 1.125, Spaenaur CP-83H	2	
G	Part	7/16" UNF x 1-1/4" Hex Bolt	1	09-1608
H	Part	7/16" UNF Hex Jam Nut	1	09-5508
J	Part	Detent Spring	1	01-0040
K	Part	Detent Ball	1	02-0018
L	Part	5/8" NC x 5/8" Hex Socket Set Screw - Cup Point	3	
M	Part	Threaded Shifter Bushing	1	101-0020
N	Part	Shifter Lug Weldment (Bolted)	1	101-0016
P	Part	Knob Collar Pipe	1	101-0019
Q	Part	Shifting Shaft	1	997-B1-71
R	Part	Shifting Fork	1	997-HT-72
S	Part	5/8" UNF Hex Jam Nut	1	09-5915
T	Part	5/8" UNF Hex Nut	1	09-5914
U	Part	Lower Shifting Shaft Bushing	1	101-0003
V	Part	3/8" NC x 1" Hex Bolt	4	09-1046

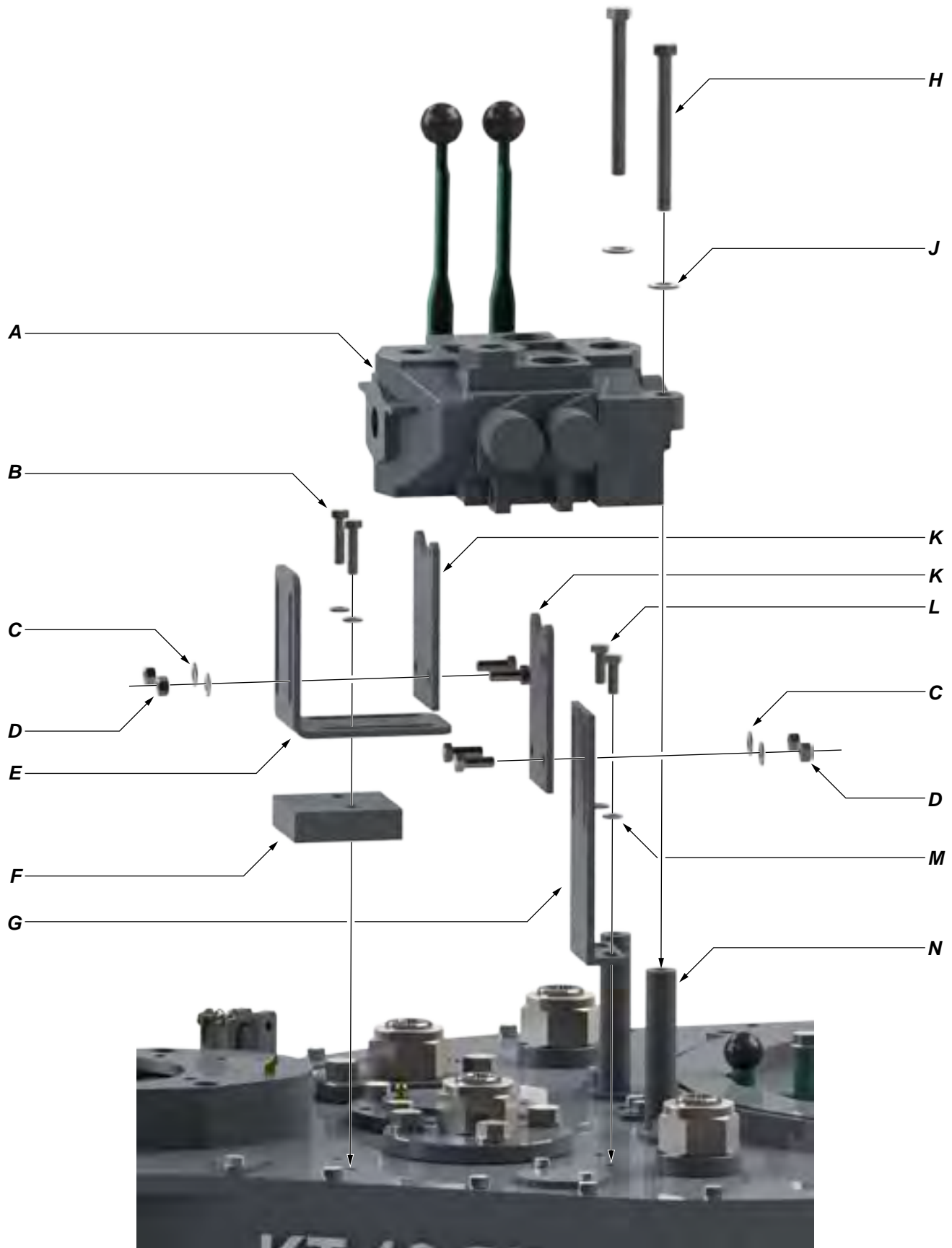

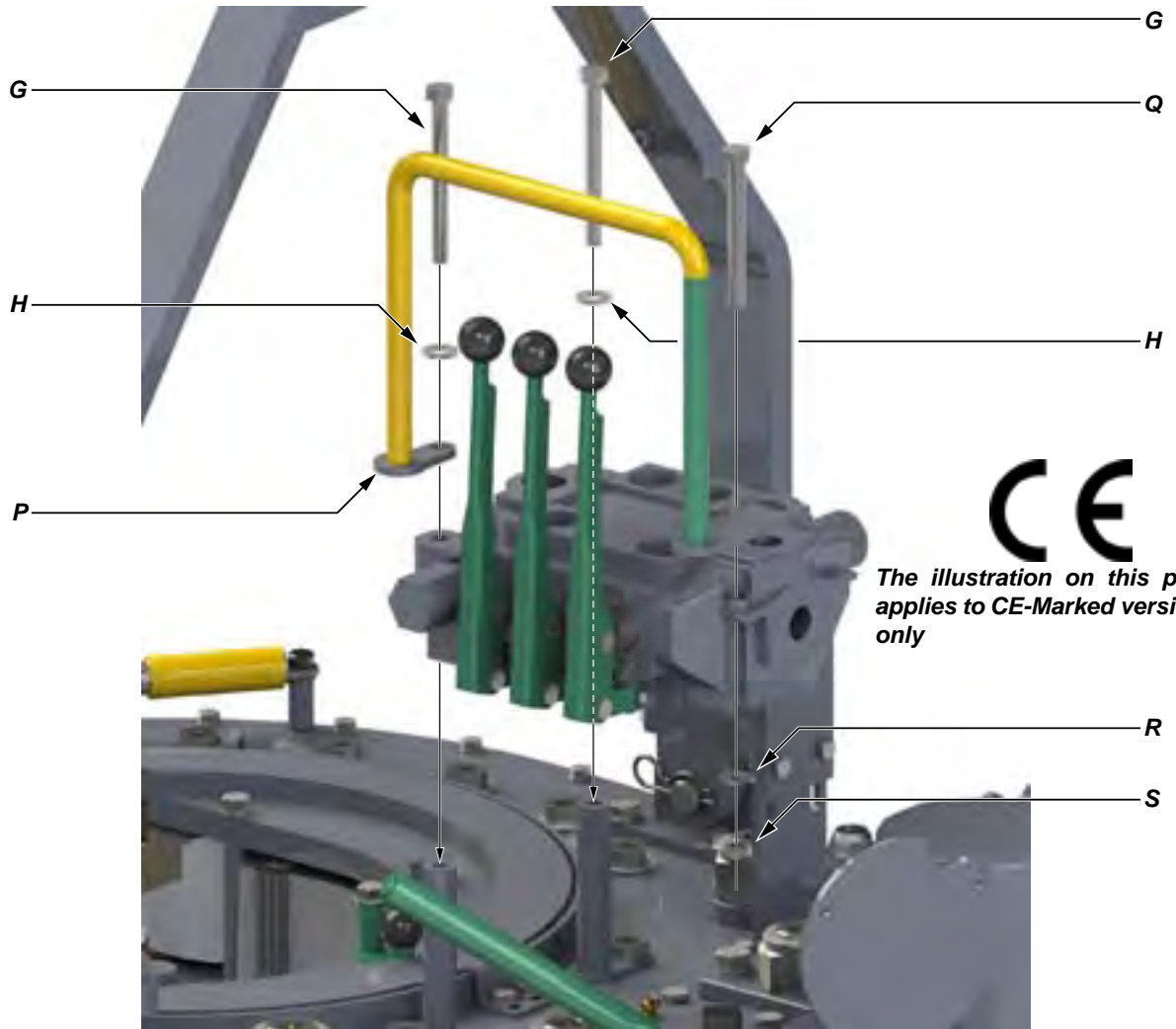

CE
The illustration on this page applies to CE-Marked versions only

Item	Type	Description	Qty	Part Number
A	Assembly	DVA Valve Assembly	1	See Pp. 2.10 - 2.14
B	Part	3/8" UNC x 1-1/2" Hex Bolt	2	09-1553
C	Part	3/8" Narrow Flat Washer	4	09-5124
D	Part	3/8" Thin Nylock Nut	4	
E	Part	Hydraulic Outlet Support Base	1	101-0023
F	Part	Hydraulic Support Mount Block	1	101-0021
G	Weldment	Hydraulic Inlet Support Base	1	101-1138
H	Part	1/2" UNC x 5" Hex Bolt	2	09-1186
J	Part	1/2" Lock Washer	2	09-5110
K	Part	Adjustable Support Plate	2	101-0022
L	Part	3/8" UNC x 1" Hex Bolt	6	09-1046
M	Part	3/8" Lock Washer	6	09-5106
N	Weldment	Hydraulic Valve Mounts	2	101-0011
P	Part	1/2" UNC x 4-1/2" Hex Bolt	1	09-1184
Q	Weldment	Valve Handle Guard Weldment	1	CE-HANDLE-3
R	Part	1/2" Narrow Flat Washer	1	09-5010
S	Part	1/2" Thin Nylock Nut	1	09-5610S

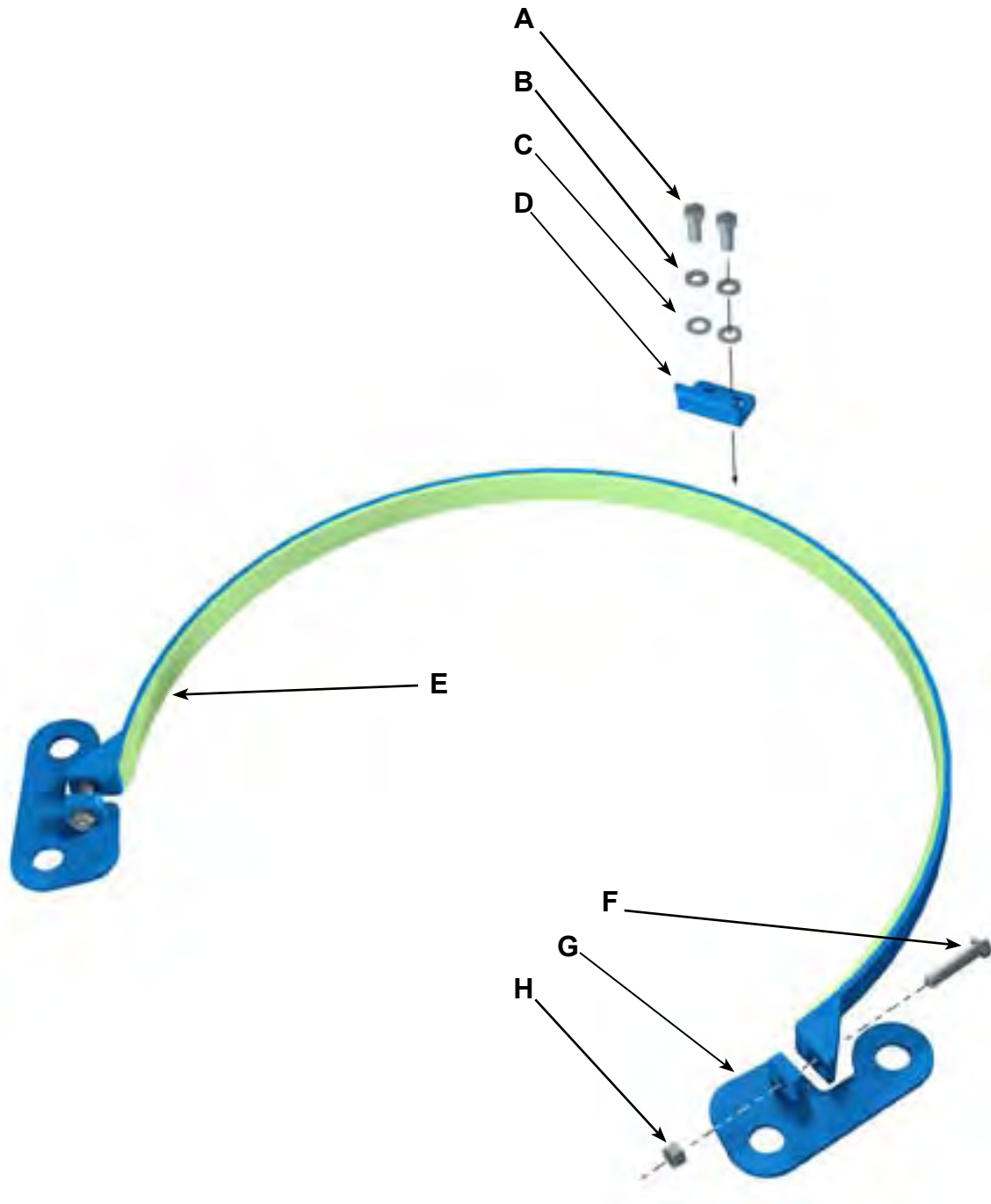

Item	Type	Description	Qty	Part Number
A	Part	3/8" NC x 1" Hex Bolt	2	09-1046
B	Part	3/8" Lock Washer	2	09-5106
C	Part	3/8" Narrow Washer	2	09-5124
D	Part	Brake Band Retainer	1	101-0140
E	Part	Brake Band Weldment With Lining	1	997-D23-29
F	Part	3/8" UNF x 1-3/4" Hex Bolt	2	19-1552
G	Part	Brake Band Lug Weldment (Left)	2	101-0007
	Part	Brake Band Lug Weldment (Right)	2	101-0008
H	Part	3/8" UNF Hex Nut		09-5906

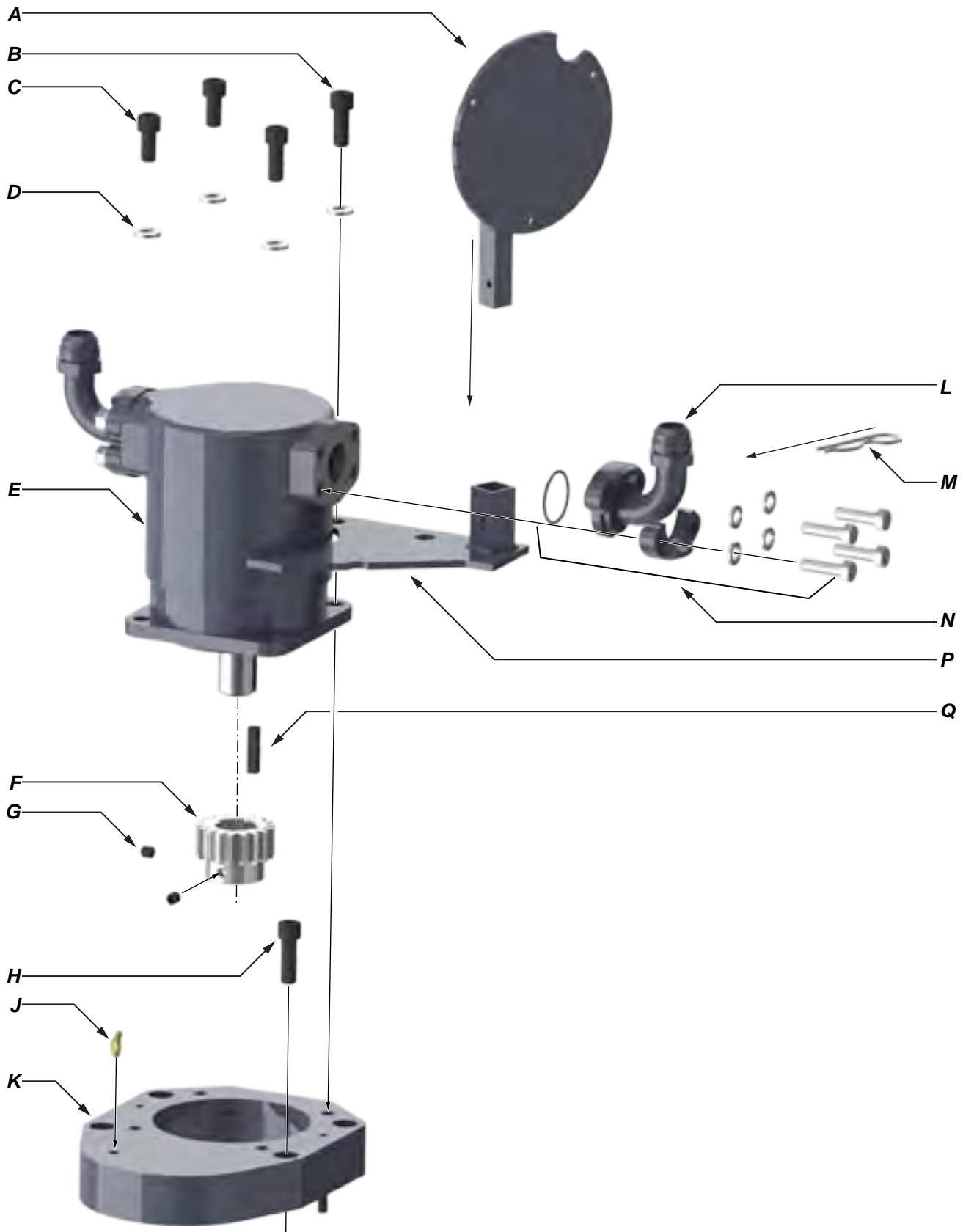



Item	Type	Description	Qty	Part Number
A	Weldment	Torque Gauge Mount Weldment	1	1500-09-03A
B	Part	1/2" UNC x 1-1/4" Hex Socket Head Cap Screw	2	09-2168
C	Part	1/2" UNC x 1" Hex Socket Head Cap Screw	2	09-2166
D	Part	1/2" Lock Washer	4	09-5110
E	Part	Hydraulic Motor (KT13625 Tong)	1	87-0112
	Part	Hydraulic Motor (LW13625 Tong)	1	87-0110
F	Part	Motor Gear	1	997-A10-149
G	Part	3/8" UNC x 3/8" Hex Socket Set Screw	2	09-2011
H	Part	1/2" UNC x 1-3/4" Hex Socket Head Cap Screw (Motor Mount)	4	09-2172
J	Part	1/8" NPT 90° Grease Fitting	1	02-0093
K	Part	Motor Mount	1	997-150
L	Part	#20 (1-1/4")/JIC 1" Flange Elbow	2	02-9216
M	Part	0.148" x 2.938" Hitch Pin	1	
N	Part	#20 (1-1/4") Split Flange Kit	2	02-9217
	Part	O-Ring	1	
	Part	#20 (1-1/4") Split Flange	2	
	Part	7/16" Lock Washer	4	
	Part	7/16" UNC x 1-1/2" Hex Bolt	4	
P	Weldment	Torque Gauge Holder Weldment	1	1500-09-04A
Q	Part	5/16" x 5/16" x 2" Square Gear Key	1	
	Kit	Seal kit for hydraulic motor		87-7110



Item	Type	Description	Qty	Part Number
A	Part	M-NPT/F-NPT 90d 1" Fitting	1	02-9221
B	Part	1" Long Nipple	1	101-0079
C	Assembly	M-ORB/F-NPT 90d 1" Fitting (Includes seals)	1	02-9206
D	Part	Hydraulic Inlet, DVA35-A880	1	10-9016
E	Part	Male 1" Quick Coupler Fitting	1	02-9214
F	Part	1" Dust Cap	1	02-9213
G	Assembly	1" Hydraulic Connection Hose Assembly	2	08-1724
H	Assembly	M-ORB/JIC LONG 90d 1" (Includes seals)	1	02-9210
J	Assembly	Motor Drain Hose Assembly	1	101-0072
K	Part	ORB HEX BUSHING	1	10-9001
L	Assembly	M-ORB/JIC 90 DEG 3/8" Fitting (Includes seals)	2	02-9200
M	Part	1-1/4" Dust Cap	1	02-9212
N	Part	Male 1-1/4" Quick Coupler Fitting	1	02-9215
P	Part	1-1/4" Long Nipple	1	101-0070
Q	Assembly	M-ORB/F-NPT 90d 1 1/4" Fitting (Includes seals)	1	02-9202
R	Part	M-NPT/F-NPT 90d 1 1/4" Fitting	1	02-9220
S	Part	Hydraulic Outlet, DVA35-TR99	1	10-0086
	Part	Hydraulic Outlet, DVA35-PB55 (Closed Centre Tongs Only)	1	08-1825
T	Part	DVA35-DA8 4WAY SAE Ports	1	10-9019
U	Assembly	Handle Assembly	3	01-0409
	Part	Hydraulic Valve Handle	1	01-0409-HANDLE
	Part	Valve Handle Link	2	01-0409-LINK
	Part	Hydraulic Handle Pin	2	01-0409-PIN1
	Part	Hydraulic Handle Auxiliary Pin	1	01-0409-PIN2
	Part	Valve Handle C-Clip	2	01-0409-CIRCLIP
	Part	Cotter Pin	2	01-0409-COTTER
V	Part	DVA35-SA8 Valve (1" ORB PORT)	1	10-9015
W	Part	DVA35-MA8 4-Way Directional Valve, SAE Port	1	10-9014
X	Assembly	Hydraulic Relief Valve (includes seals)	1	10-0010R
Y	Part	1" Orb Plug Fitting (includes o-ring)	1	02-9222
SEAL KIT		Seal kit for DVA35 Valve		02-9133

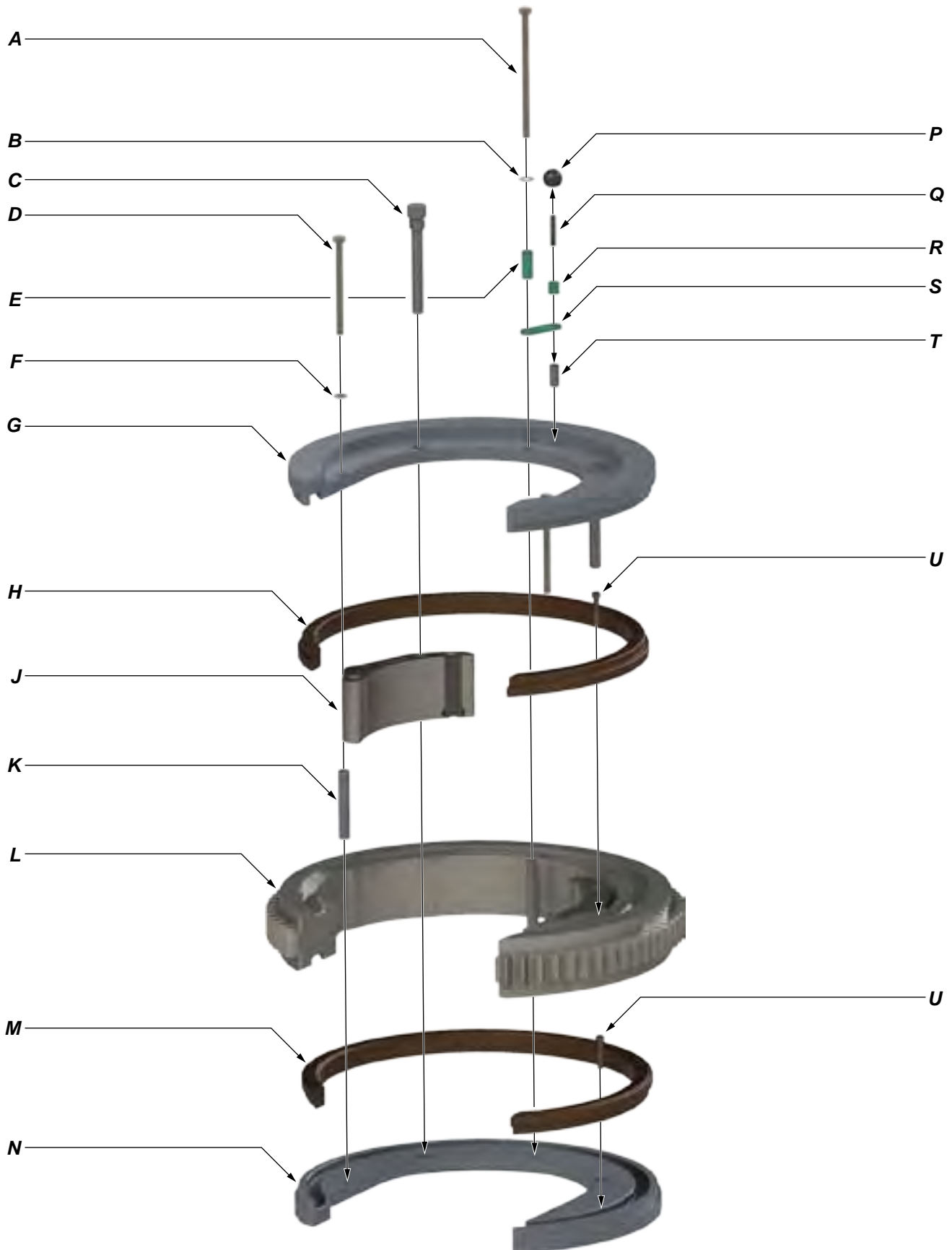

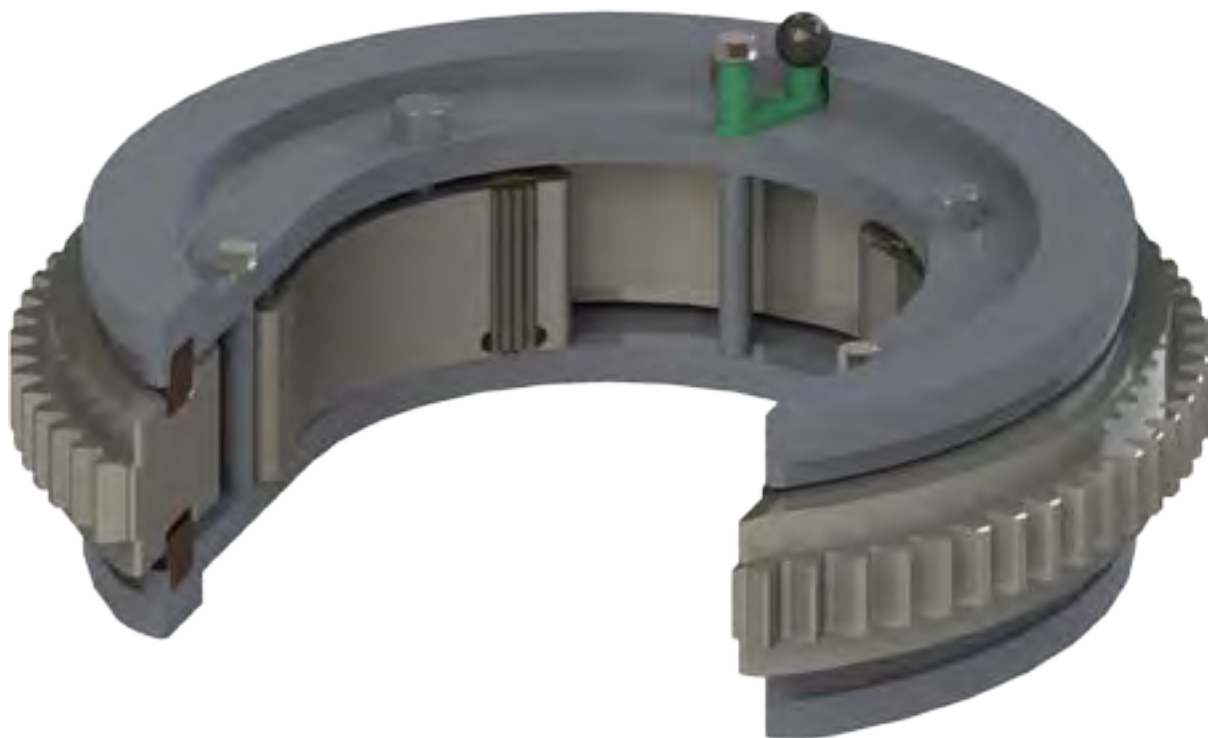

Item	Type	Description	Qty	Part Number
A	Part	1/2" UNC x 8" Hex Bolt	1	09-1198
B	Part	1/2" Narrow Flat Washer	1	09-5119
C	Part	Jaw Pivot Bolt	2	997-D3-28
D	Part	1/2" UNC x 6" Hex Bolt	2	09-1190
E	Part	Backing Pin Spacer, Long	1	101-4093
F	Part	1/2" Lock Washer	2	09-5110
G	Part	Top Cage Plate	1	997-HT-21
H	Part	Support Ring (Top)	1	997-HT-23-TOP
J	Part	Jaw Assembly (13-5/8" shown)	2	See Pp. 2.17
K	Part	Cage Plate Spacer	3	997-38B
L	Part	Rotary Gear	1	997-D1-B
M	Part	Support Ring (Bottom)	1	997-HT-23-BOT
N	Part	Bottom Cage Plate	1	997-HT-22
P	Part	Backing Pin Knob	1	02-0017
Q	Part	3/8" UNF x 2" Threaded Stud	1	101-4097
R	Part	Backing Pin Spacer, Short	1	101-4096
S	Part	Backing Pin Retainer	1	101-4139
T	Part	Backing Pin	1	101-4142
U	Part	3/8" UNC x 1-3/4" Hex Socket Head Cap Screw	22	09-2052

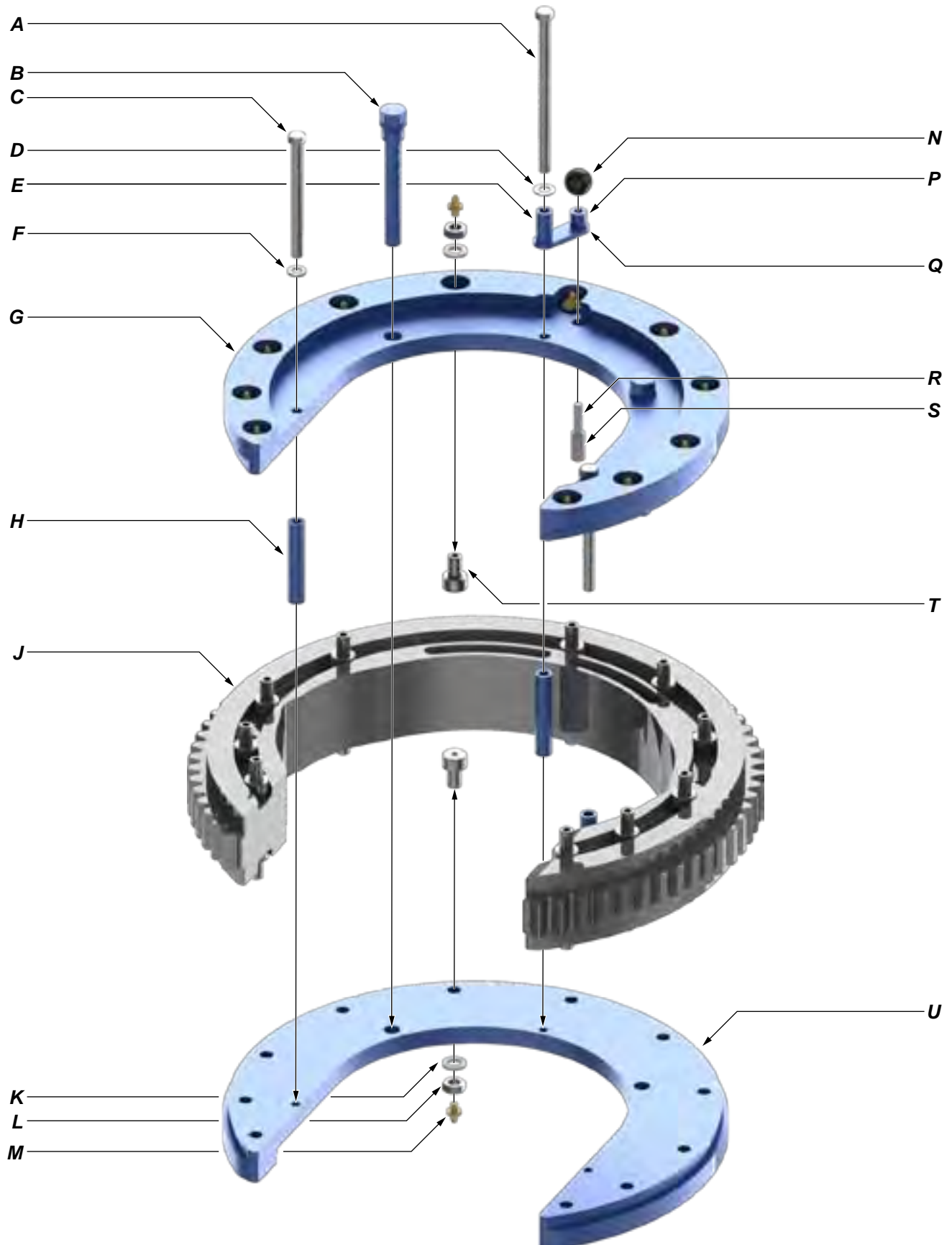

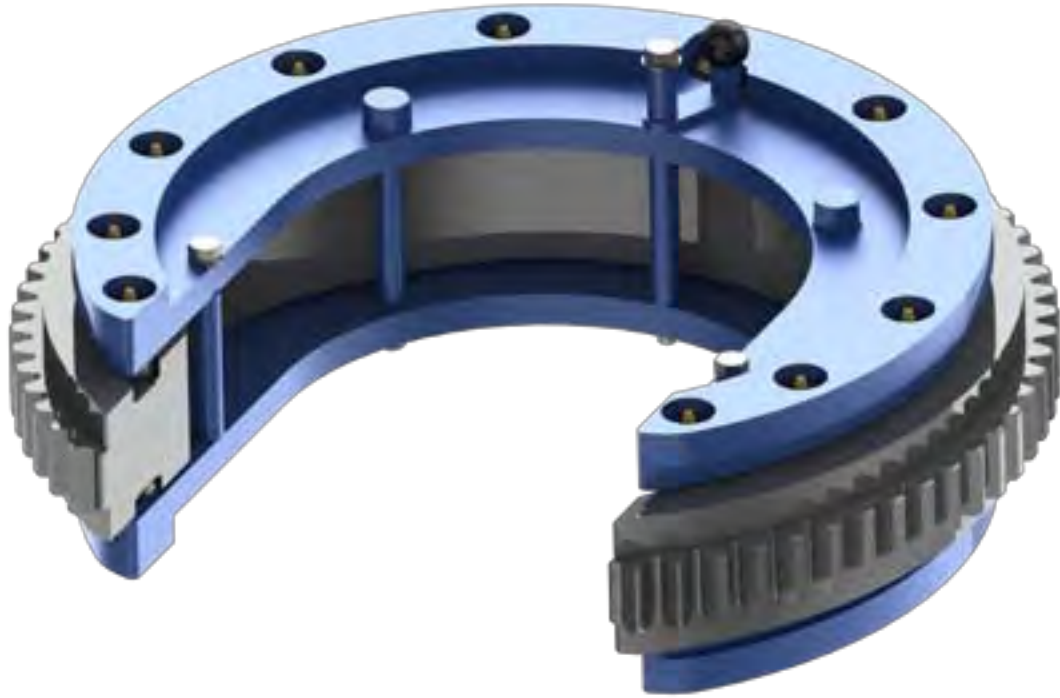

Item	Type	Description	Qty	Part Number
A	Part	1/2" UNC x 8" Hex Bolt	1	09-1198
B	Part	Jaw Pivot Bolt	2	997-D3-28
C	Part	1/2" UNC x 6" Hex Bolt	2	09-1190
D	Part	1/2" Narrow Washer	1	09-5119
E	Part	Backing Pin Spacer, Long	1	101-4093
F	Part	1/2" Lock Washer	2	09-5110
G	Part	Top Cage Plate	1	997-D2-21
H	Part	Cage Plate Spacer	3	997-D3-38
J	Part	Rotary Gear	1	997-D1-B
K	Part	5/8" Lock Washer	22	09-5114
L	Part	5/8" UNF Hex Jam Nut	22	09-5514
M	Part	1/8" NPT Grease Fitting	22	02-0005
N	Part	Backing Pin Knob	1	02-0017
P	Part	Backing Pin Spacer, Short	1	101-4096
Q	Part	Backing Pin Retainer	1	101-4139
R	Part	3/8" UNF x 2" Threaded Stud	1	101-4097
S	Part	Backing Pin	1	101-4142
T	Part	Cage Plate Cam Follower	22	02-0016
U	Part	Bottom Cage Plate	1	997-D2-22

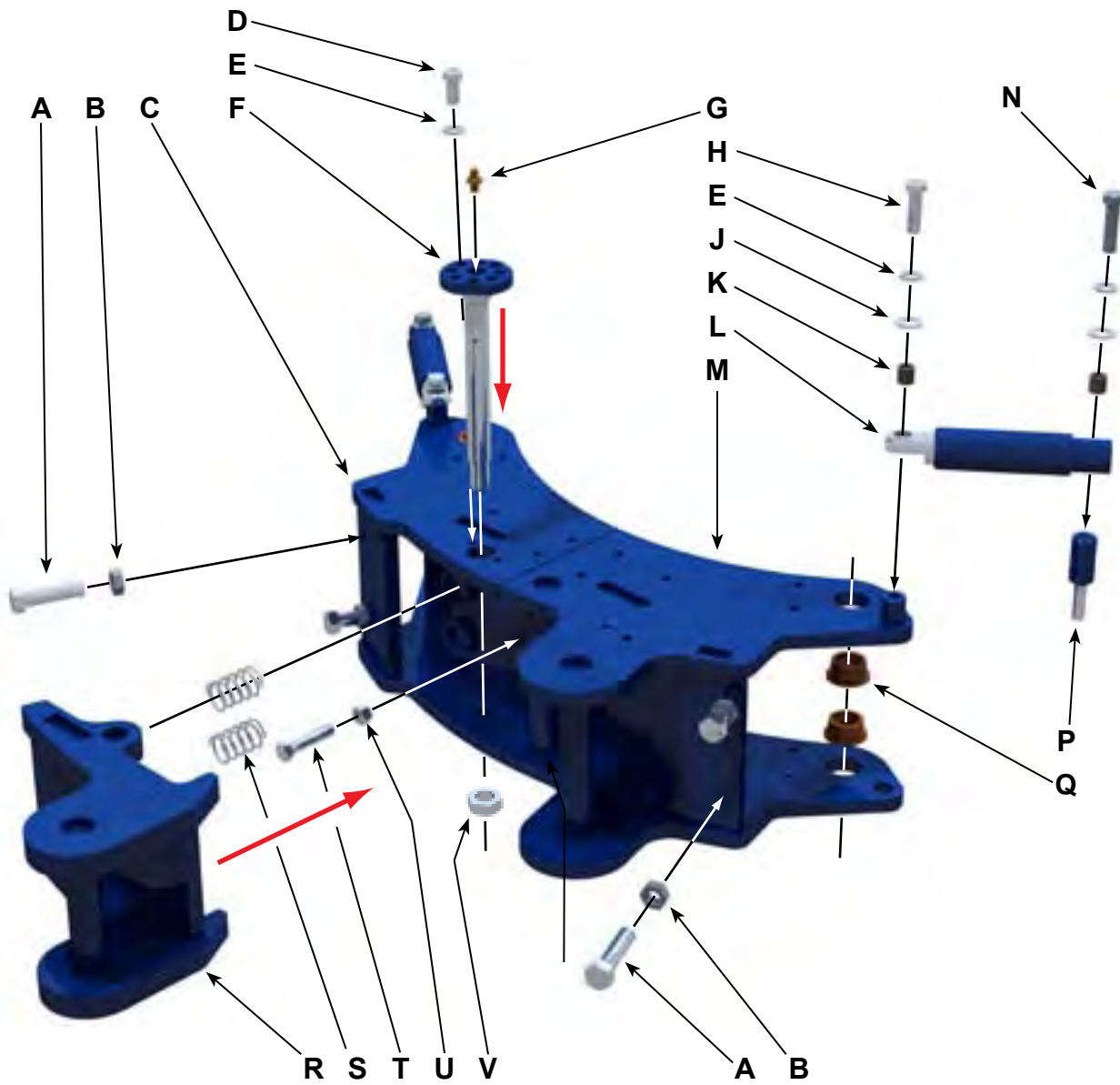



Item	Type	Description	Qty	Part Number
A	Part	1/2" NC x 2" Hex Bolt	4	09-1174
B	Part	1/2" NC Hex Jam Nut	4	09-5810
C	Weldment	RH Door Weldment	1	101-0034
D	Part	3/8" NC x 3/4" Hex Bolt	1	09-1044
E	Part	3/8" Carbon Steel Lock Washer	9	09-5106
F	Part	Door Latch Cam	1	997-A11-14
G	Part	Grease Fitting	1	02-0097
H	Part	3/8" NC x 1-1/4" Hex Bolt	2	09-1048
J	Part	3/8" Narrow Washer	4	09-5124
K	Part	Door Stop Spacer	4	997-13B
L	Assembly	Door Cylinder Assembly	2	101-0069
M	Weldment	Left Hand Door Weldment	1	101-0032
N	Part	3/8" NC x 1-1/2" Hex Bolt	2	09-1553
P	Part	Door Cylinder Mounting Lug	2	1050-12-001
Q	Part	Shoulder Bushing	4	101-0045
R	Weldment	Door Latch Weldment	1	101-0038
S	Part	Door Latch Spring	2	997-16
T	Part	3/8" NC x 1-3/4" Hex Bolt	1	09-1557
U	Part	3/8" NC Hex Nut	1	09-5806
V	Part	5/8" NC Hex Jam Nut	1	09-9141

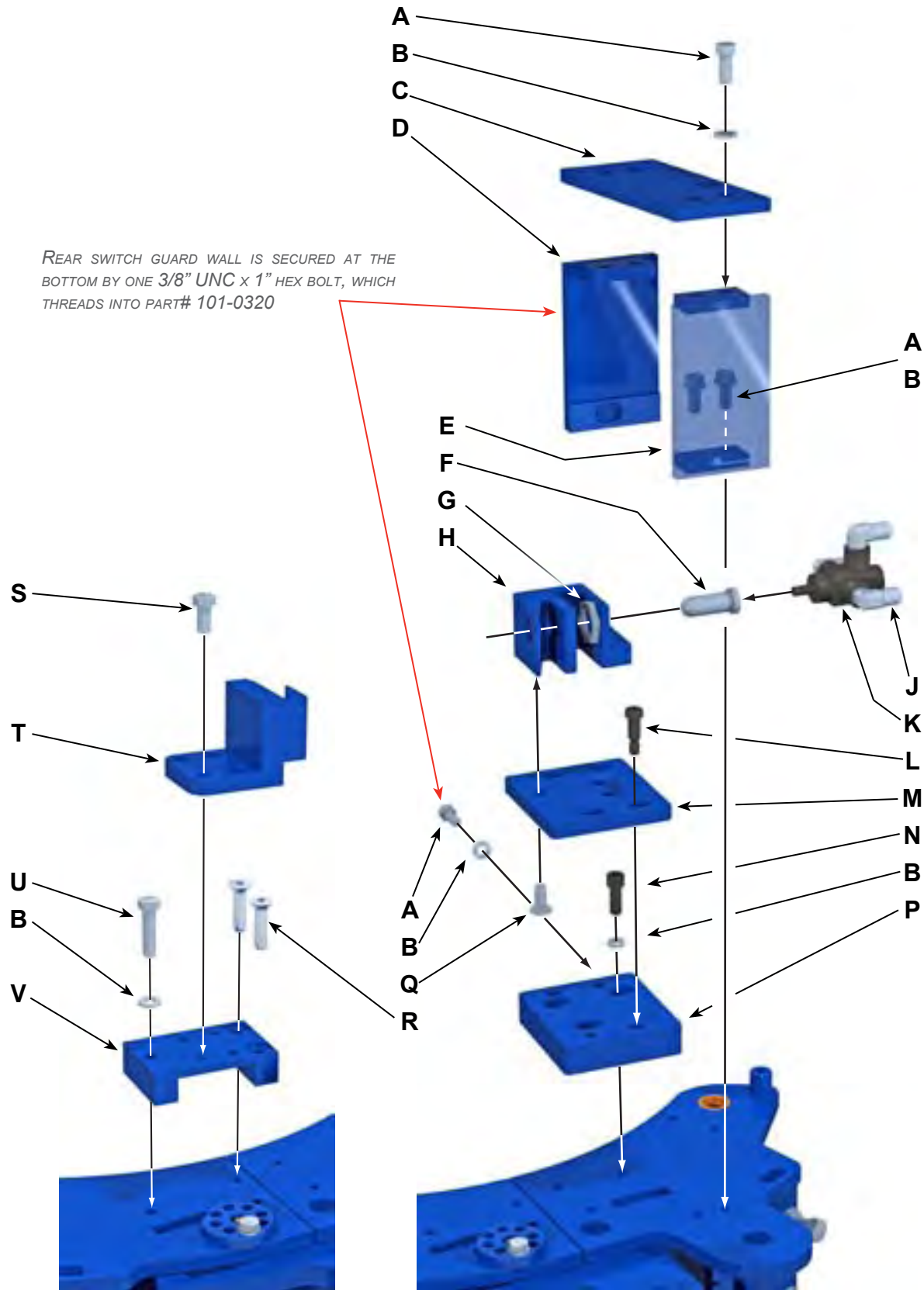



Item	Type	Description	Qty	Part Number
A	Part	3/8" UNC x 1" Hex Bolt	7	09-1046
B	Part	3/8" Carbon Steel Lock Washer	11	09-5106
C	Part	Switch Guard Plate	1	101-0384
D	Weldment	Rear Switch Guard Wall Weldment	1	101-0386
E	Weldment	Front Switch Guard Wall Weldment	1	101-0387
F	Part	Load Plunger	1	AE12-306
G	Part	15/16" Valve Lock Nut	1	09-0278
H	Part	Safety Door Latch Block	1	AE13-301S
J	Part	1/4 inch NPT - JIC 90 degree Elbow	3	08-0284
K	Part	Deltrol Gauge Isolator Valve GI21S	1	08-0337M
L	Part	5/16" X 3/4" UNC Shoulder Bolt	4	09-0227
M	Part	Door Latch Plate	1	AE13-311
N	Part	3/8" UNC x 1" Hex SHCS	3	09-1738
P	Part	Safety Door Latch Plate	1	101-0320
Q	Part	3/8" UNC x 3/4" Hex FHCS	3	09-4044
R	Part	3/8" UNC x 1-1/2" Hex FHCS	2	09-4050
S	Part	3/8" UNC x 3/4" Hex Bolt	4	09-1044
T	Part	Safety Door Latch Block	1	AE13-302M
U	Part	3/8" UNC x 1-1/2" Hex Bolt	1	09-1553
V	Part	Safety Door Latch Block	1	101-0319

CE-Marked tongs use the following parts in place of those in the previous table:

Item	Type	Description	Qty	Part Number
A	Part	3/8" UNC x 1" Hex Bolt, SS Drilled	5	09-1046SSD
L	Part	5/16" x 3/4" Hex Socket Shoulder Bolt, UNC, Drilled	4	09-0227SSD
S	Part	3/8" UNC x 3/4" Hex Bolt, SS Drilled	4	09-1044SSD
U	Part	3/8" UNC x 1-1/2" Hex Bolt, SS Drilled	1	09-1553SSD

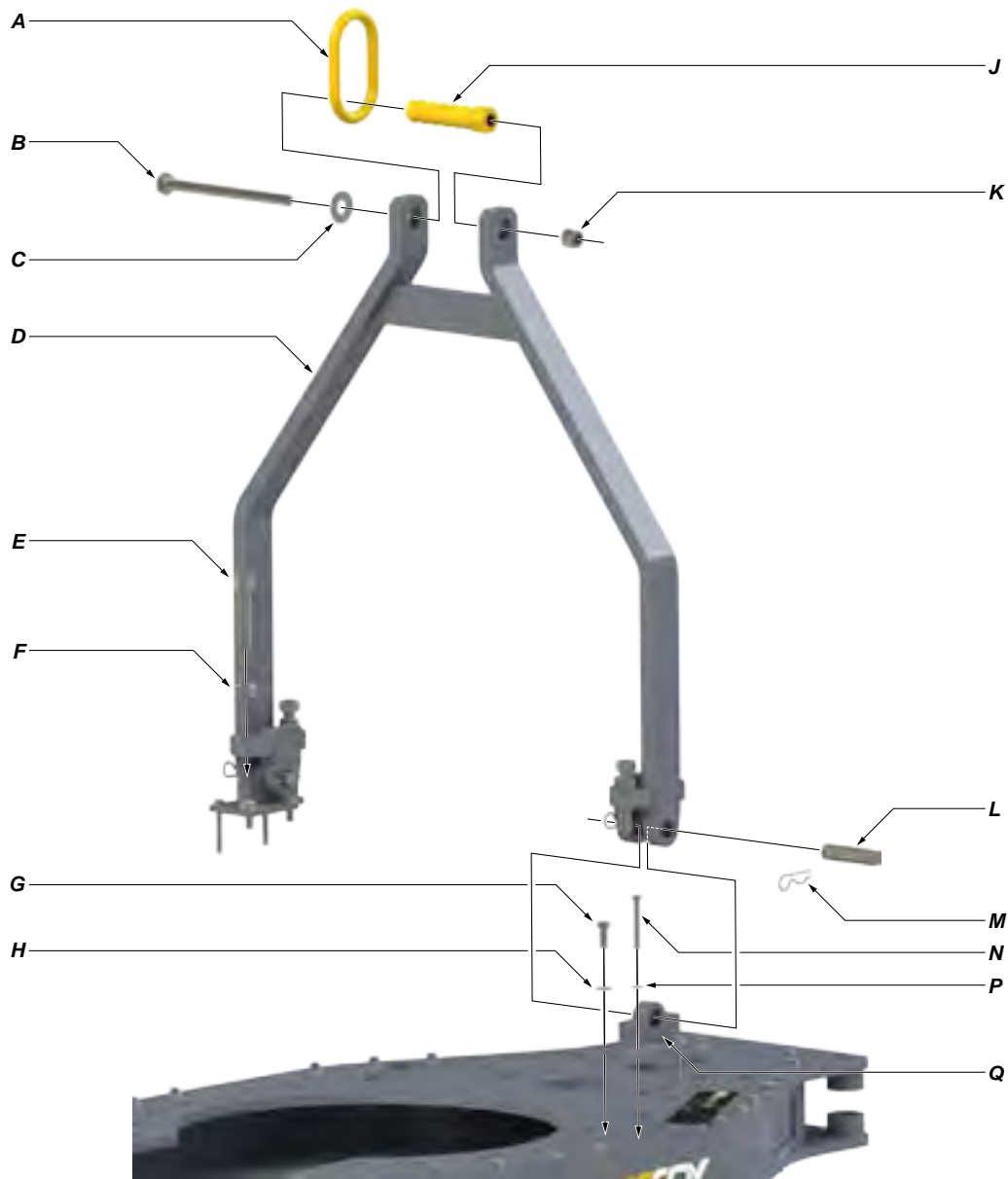

ALL FASTENERS USED DURING REASSEMBLY OF LOAD-BEARING COMPONENTS (CHAIN SLINGS, RIGID SLINGS, BACKUP LEGS) MUST BE TIGHTENED TO THE CORRECT TORQUE. THREADED FASTENERS USED IN LOAD-BEARING DEVICES MUST BE SECURED WITH RED LOCTITE™.

Item	Type	Description	Qty	Part Number
A	Part	Master Lifting Link	1	02-0516
B	Part	3/4" UNC x 9-1/2" Hex Bolt	1	09-1324
C	Part	3/4" Flat Washer	1	09-5018
D	Weldment	Rigid Sling Weldment	1	101-1360
E	Part	Leveling Bolt	4	1053-C-1L
F	Part	3/4" Hex Nut	4	09-5818
G	Part	1/2" UNC x 1-1/4" Hex Bolt	4	09-1168
H	Part	1/2" Lock Washer	4	09-5110
J	Part	Adjusting Helix	1	1095-220

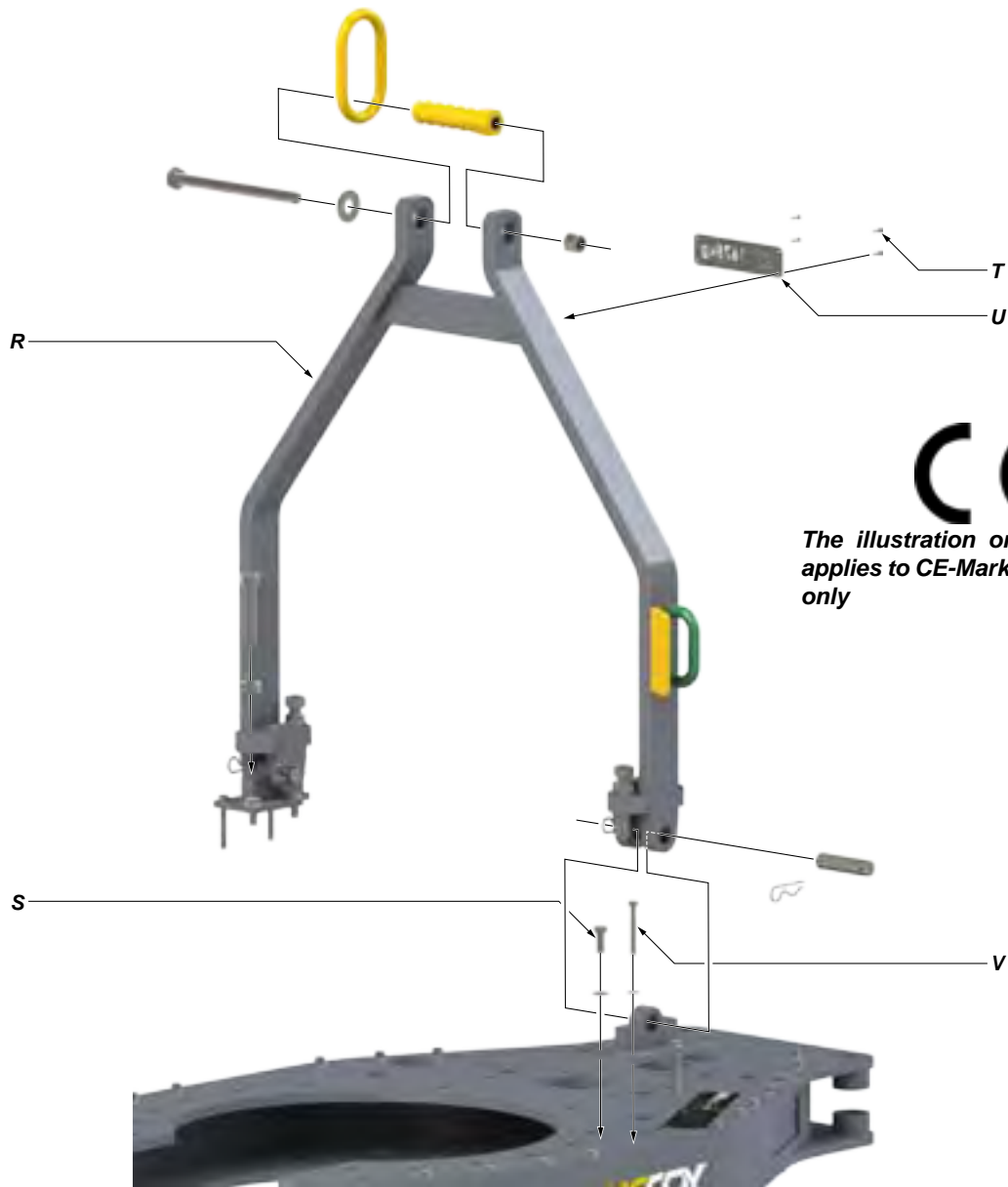

CE
The illustration on this page applies to CE-Marked versions only

Item	Type	Description	Qty	Part Number
K	Part	3/4" UNC Hex Nylock Nut	1	1429-39-02
L	Part	Hanger Pin	1	1095-218
M	Part	R-Clip Pin	4	02-0981
N	Part	3/8" UNC x 1-3/4" Hex Bolt	4	09-1557
P	Part	3/8" Lock Washer	4	09-5124
Q	Part	RH Bolted Hanger Weldment	1	101-1364
	Part	LH Bolted Hanger Weldment	1	101-1361
The following parts apply to rigid slings on CE-Marked assemblies only				
R	Weldment	Rigid Sling Weldment	1	101-1360
S	Part	1/2" UNC x 1-1/4" Wire-Drilled Hex Bolt	4	09-1168SSD
T	Part	Rivet	4	02-0557
U	Part	Mass Placard, KT13625+FBU	1	CE-MASS-KT13625FBU
V	Part	3/8" UNC x 1-3/4" Wire-Drilled Hex Bolt	4	09-1557SSD

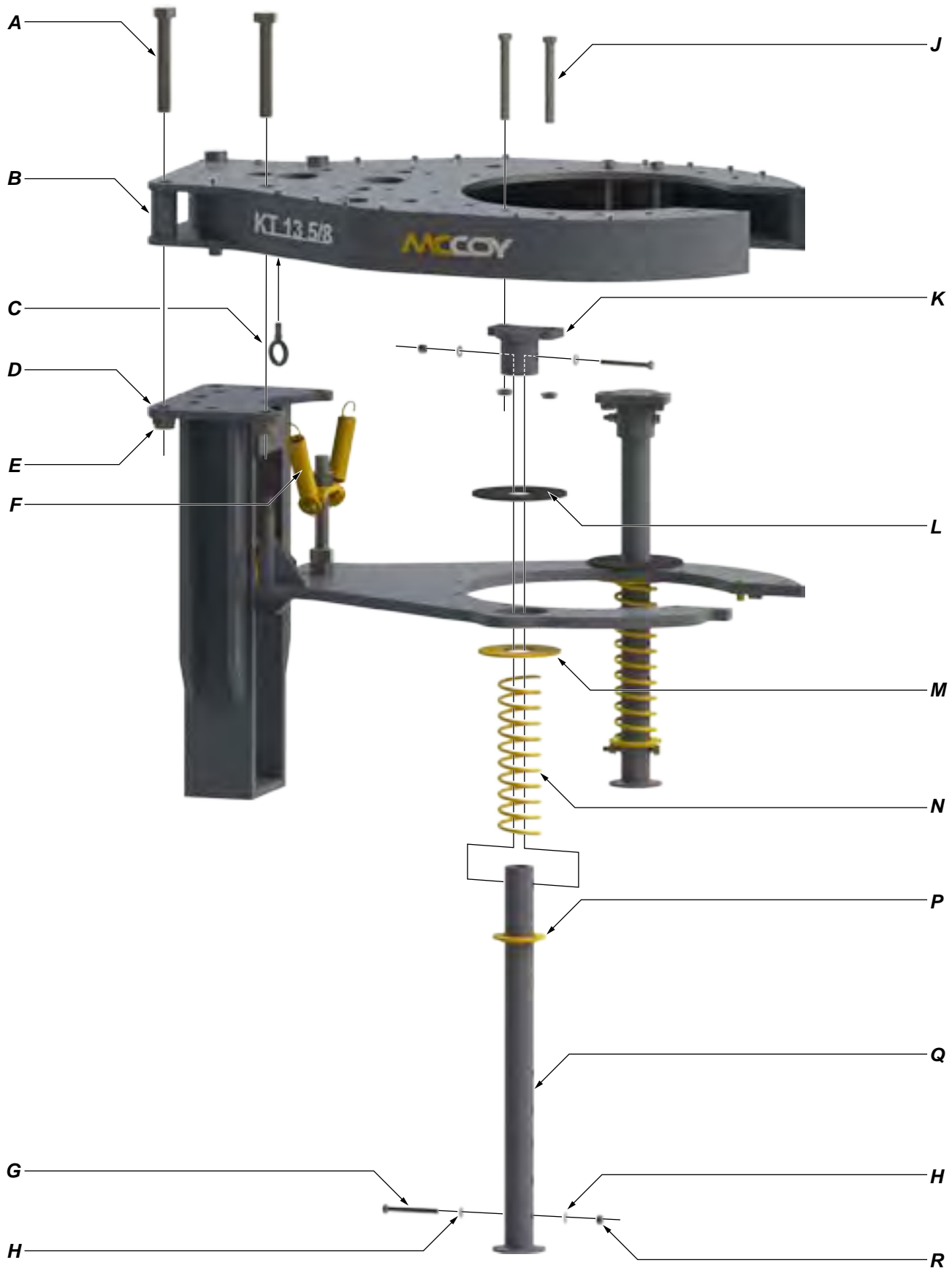



ALL FASTENERS USED DURING REASSEMBLY OF LOAD-BEARING COMPONENTS (CHAIN SLINGS, RIGID SLINGS, BACKUP LEGS) MUST BE TIGHTENED TO THE CORRECT TORQUE. THREADED FASTENERS USED IN LOAD-BEARING DEVICES MUST BE SECURED WITH RED LOCTITE™.

<i>Item</i>	<i>Type</i>	<i>Description</i>	<i>Qty</i>	<i>Part Number</i>
A	Part	1-1/4" UNC x 8" Heavy Hex Bolt	4	09-0222
B	Part	Rear Lug Spacer	2	101-1546
C	Part	Eye Bolt	2	02-0262
D	Weldment	Rear Leg Weldment	1	997-915-00
E	Part	1-1/4" UNC Nylock Nut	4	09-1484
F	Part	Rear Leveling Spring	2	1302-905-06
G	Part	1/2" UNC x 4-1/2" Hex Bolt	4	09-1184
H	Part	1/2" Flat Washer	8	09-5010
J	Part	Support Roller Shaft (Front Leg Mounts)	4	101-1268
K	Weldment	Front Leg Mount	2	997-917-00A
L	Part	Rubber Guard (CE-Marked Tongs Only)	2	101-5733
M	Part	Top Leg Spring Cap	2	1302-905-03B
N	Part	Front Leg Spring	2	997-906-02
P	Part	Bottom Leg Spring Cap	2	1302-905-03A
Q	Weldment	Front Leg Weldment	2	997-917-00B
	Weldment	Front Leg Weldment (CE-Marked Tongs Only)	2	101-5784
R	Part	1/2" UNC Nylock Nut	4	09-5610

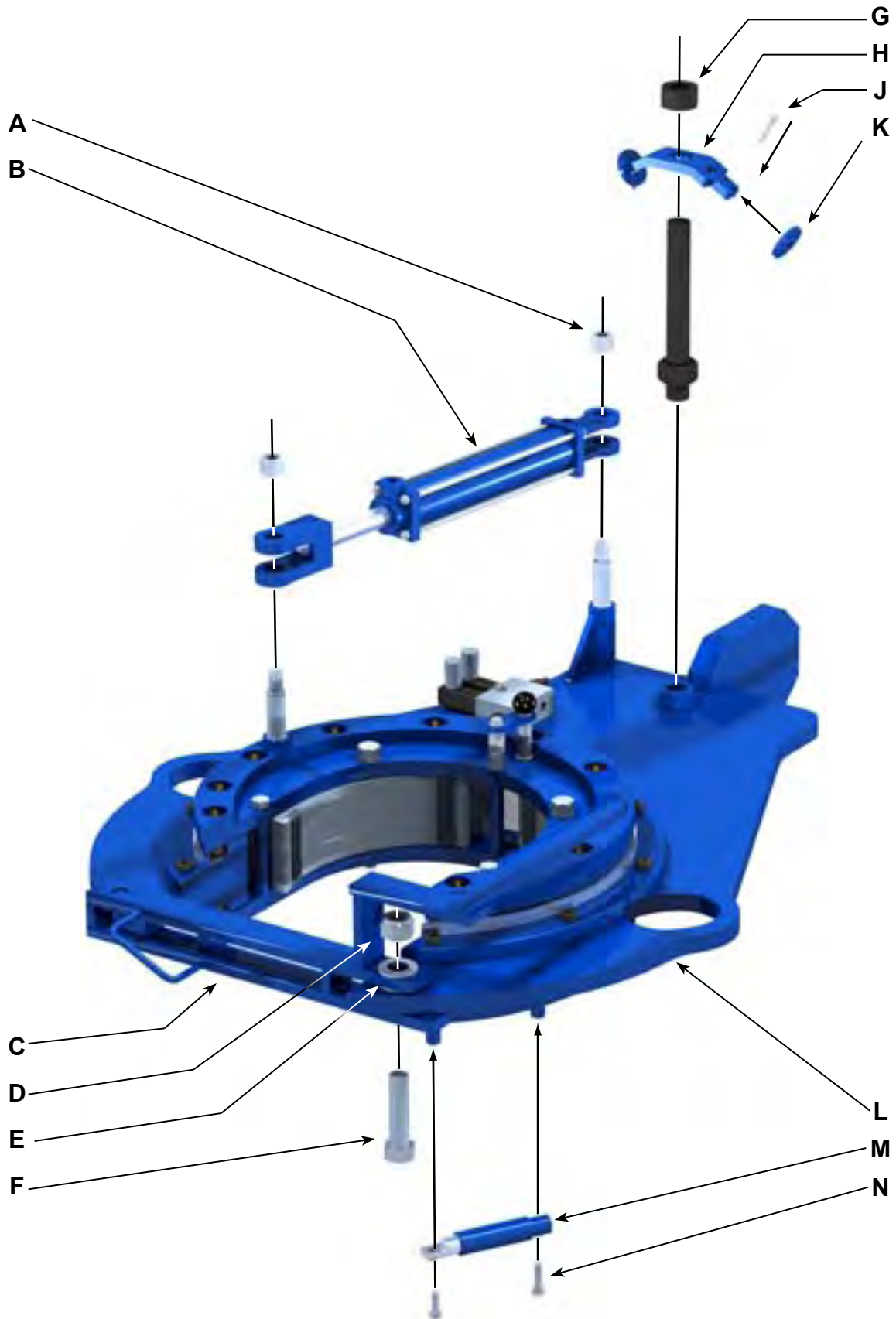

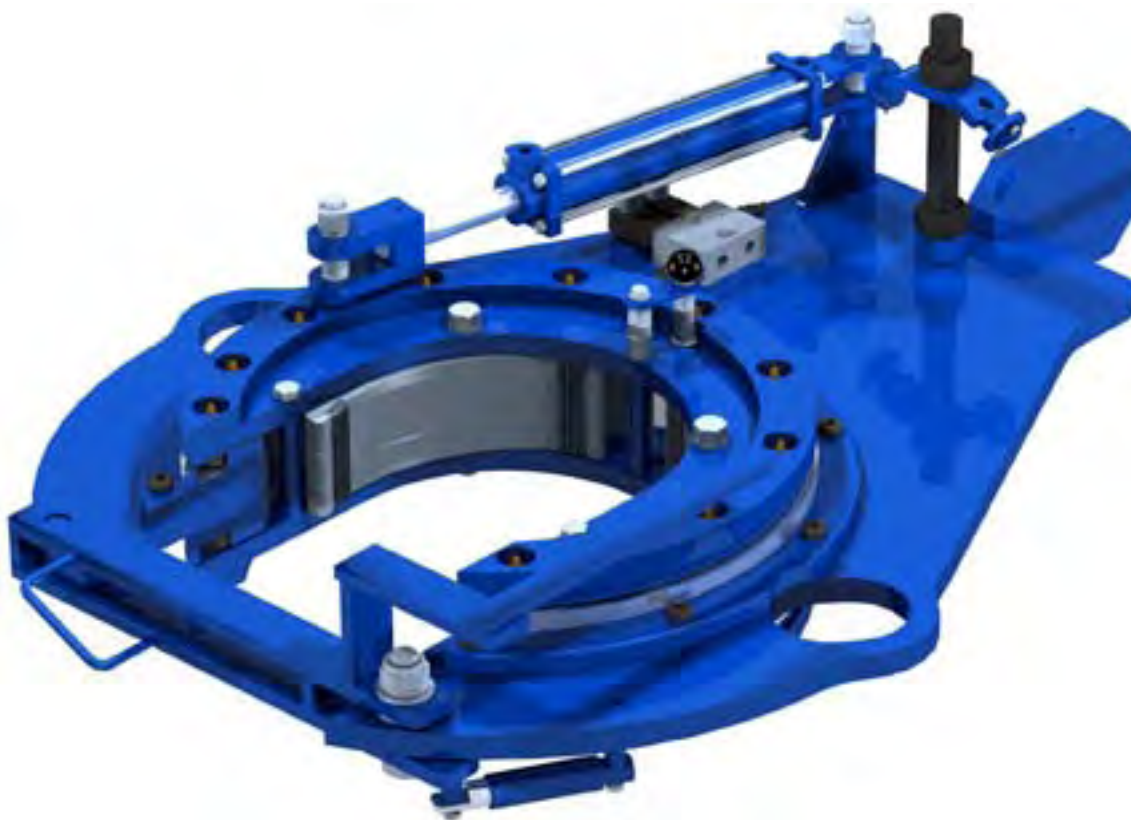

Item	Type	Description	Qty	Part Number
A	Part	3/4" UNC Hex Nylock Nut	2	1429-39-02
B	Part	Cam Cylinder	1	1364-902
C	Weldment	Backup Door Weldment	1	997-05-00
D	Part	1" UNC Nylock Nut	1	09-5725
E	Part	1" Plain Narrow Washer	2	09-5120
F	Part	1" UNC x 4" Heavy Hex Bolt	1	09-1422
G	Part	1-1/4" UNC Heavy Hex Nut	2	09-5832
H	Part	Rear Leg Spring V-Bracket	1	1483-500-00-04
J	Part	3/16" x 1-1/4" Extended Prong Square Cut Cotter Pin	2	
K	Part	Rear Leg Spring Retainer	2	1483-500-00-04B
L	Weldment	Backup Body Weldment	1	997-521B-00
M	Part	Door Cylinder	1	101-0069
N	Part	3/8" UNC x 1-1/2" Hex Bolt	2	09-1553

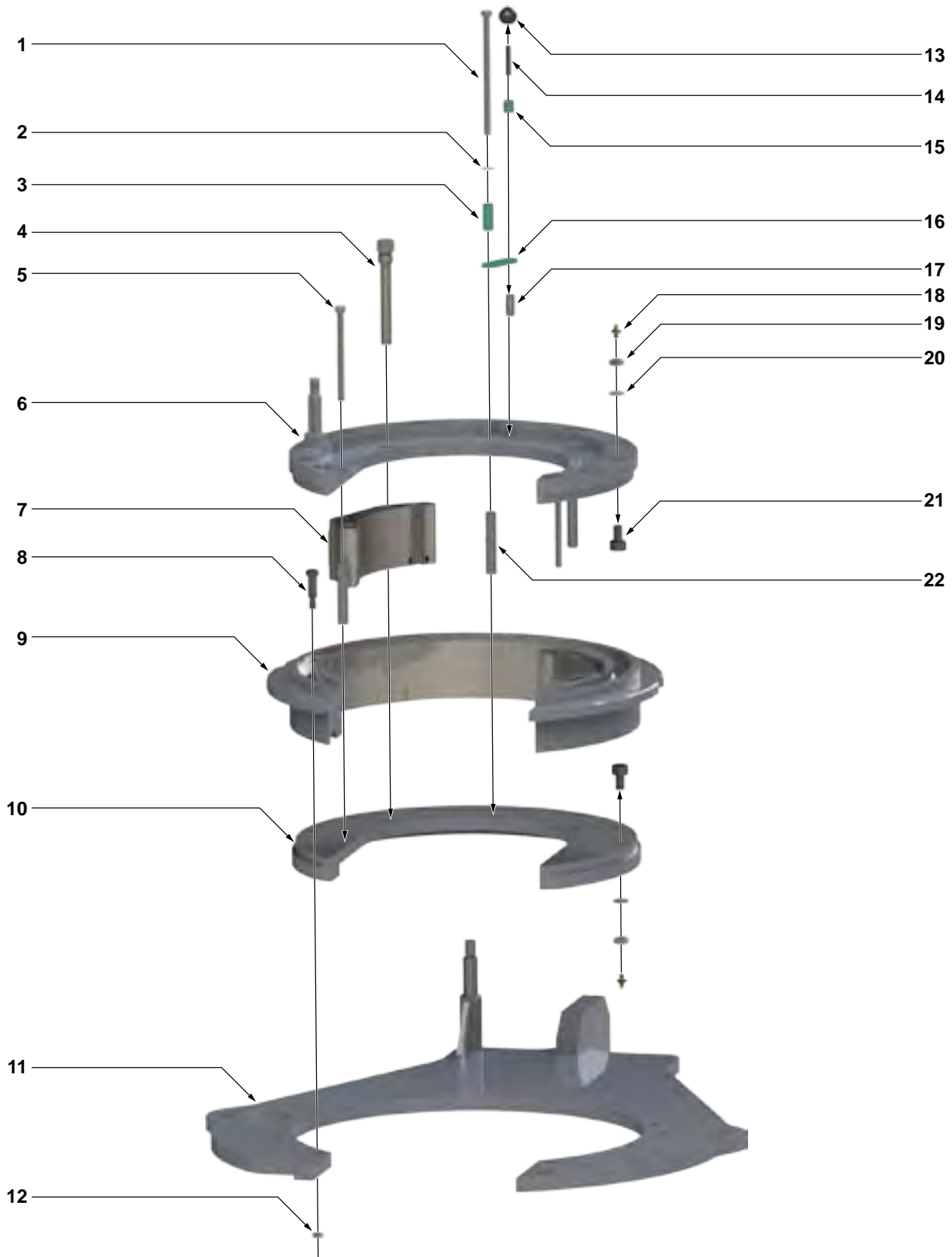



Item	Type	Description	Qty	Part Number
A	Part	1/2" UNC x 8" Hex Bolt	1	09-1198
B	Part	1/2" Narrow Flat Washer	1	09-5119
C	Part	Backing Pin Spacer, Long	1	101-4093
D	Part	Jaw Pivot Bolt	2	997-D3-28
E	Part	1/2" UNC x 6" Hex Bolt	2	09-1190
F	Weldment	Top Cage Plate Weldment	1	101-1241
G	Part	Jaw Assembly (13-5/8" shown)	2	See Pp. 2.17
H	Part	5/8" x 1-1/2" Hex Socket UNC Shoulder Screw	9	09-0116
J	Part	Backup Cam Gear	1	997-500-01
K	Part	Bottom Cage Plate	1	997-D2-22
L	Weldment	Backup Body Plate Weldment (shown for illustration purposes only)	1	
M	Part	1/2" UNC Thin Nylock Nut	9	09-5610S
N	Part	Backing Pin Knob	1	02-0017
P	Part	3/8" UNF x 2" Threaded Stud	1	101-4097
Q	Part	Backing Pin Spacer, Short	1	101-4096
R	Part	Backing Pin Retainer	1	101-4139
S	Part	Backing Pin	1	101-4142
T	Part	1/8" NPT Grease Fitting	22	02-0005
U	Part	5/8" UNF Hex Jam Nut	22	09-5514
V	Part	5/8" Carbon Steel Lock Washer	22	09-5114
W	Part	Cam Follower	22	02-0016
X	Part	Cage Plate Spacer	3	997-D3-38



***This page intentionally
left blank***

A. BASIC TORQUE MEASUREMENT

Basic torque measurements are performed using a simple hydraulic measurement system. A hydraulic load cell connects to a calibrated torque gauge through a reinforced flexible hydraulic hose. The torque gauge is factory-calibrated to display accurate torque measurements for a tong or tong and backup assembly with a particular arm length. The arm length is a measurement from the centre of the pipe or casing to the centre of the force being applied to the load cell.

Two load cell options are available. A tension load cell is typically used with a suspended stand-alone tong. This application requires that the load cell be attached to the rear of the tong as part of the restraint line that opposes the force generated when the tong makes up or breaks out a joint. A compression load cell is used in a tong and backup assembly, and is typically located on the rear of the backup between the backup and a stationary frame. The load cell must be located in the centre of the compression force vector generated between the backup and the frame.

Hydraulic force generated by a load cell is transmitted to the torque gauge via a reinforced flexible hydraulic line. The hydraulic force is displayed as torque in units of Ft.-Lbs (or, optionally, newton-meters). The torque gauge has a red "peak torque" indicator that tracks with the torque gauge needle to the point of highest torque, and remains at the point of highest torque until manually reset. Note that every model of tong and tong and backup assembly has a unique arm length, and the torque gauge must be calibrated for that arm length. Torque gauges that are not calibrated for the arm length of the tool in service will not display correct torque. To ensure correct torque measurement, ensure the arm length or "handle" as displayed on your torque gauge matches the arm length of the tool in service as listed on the specifications page of the technical manual.

The images on this page are for illustration purposes only and may not accurately represent the torque gauge and load cell that have been supplied with your equipment.



THE IMAGES DISPLAYED ARE SUPPLIED FOR ILLUSTRATION PURPOSES ONLY



ILLUSTRATION 6.A.1: TORQUE GAUGE (FOR ILLUSTRATION PURPOSES ONLY)



ILLUSTRATION 6.A.2: TENSION LOAD CELL



ILLUSTRATION 6.A.3: COMPRESSION LOAD CELL

Torque gauges and load cells are supplied as a matched calibrated pair. Substituting one or the other will render the calibration inaccurate even if the actual model numbers appear to be identical. The serial numbers of matching load cell and torque gauges are clearly identified on the calibration certificate. Should you suspect the accuracy of your torque measurements, or wish to replace either component the pair should be returned to the factory for re-calibration before placing into service.



TORQUE GAUGES AND LOAD CELLS ARE FACTORY-SUPPLIED SUPPLIED AS MATCHED CALIBRATED PAIRS. IF REPLACING EITHER COMPONENT THE LOAD CELL AND TORQUE GAUGE MUST BE RETURNED TO THE FACTORY FOR RE-CALIBRATION BEFORE PLACED INTO SERVICE.

BASIC TORQUE MEASUREMENT (Continued:)

The images on the preceding page are for illustration purposes only and may not accurately represent the torque gauge and load cell that have been supplied with your equipment. Please note that the parts listed in the following table are correct for accurate torque measurement while using the equipment for which this manual is supplied.



THE TORQUE GAUGE USED IS FULLY DEPENDANT UPON THE ARM LENGTH AND TORQUE RANGE OF THE EQUIPMENT IN USE. THE PART NUMBERS LISTED IN THE FOLLOWING TABLE ARE CORRECT FOR ACCURATELY MEASURING TORQUE USING THE EQUIPMENT FOR WHICH THIS MANUAL IS SUPPLIED.

Applies to KT13625 Tong & FARR® Backup Assemblies (Imperial)				
Item	Type	Description	Qty	Part Number
	Assembly	32" - 40,000 Lbs-Ft Torque Measurement Assembly	1	10-0071C
A	Part	Compression Load Cell	1	10-0008C
B	Part	40,000 Lbs-Ft. Gauge, 32" Arm Length (includes following)	1	10-0071G
	Part	1/4" FNPT TEE	1	60-0364
	Part	1/4" NPT Street Elbow	1	08-0023
	Part	1/4" NPT Cap	1	08-0424
C	Part	5 Ft. Hose Assembly	1	02-0069

Applies to KT13625 Tong & FARR® Backup Assemblies (Metric)				
Item	Type	Description	Qty	Part Number
	Assembly	32" - 55000 Nm Torque Measurement Assembly	1	10-0071C-M
A	Part	Compression Load Cell	1	10-0008C
B	Part	55000 Nm Gauge, 32" Arm Length (includes following)	1	10-0071G-M
	Part	1/4" FNPT TEE	1	60-0364
	Part	1/4" NPT Street Elbow	1	08-0023
	Part	1/4" NPT Cap	1	08-0424
C	Part	1.5 m Hose Assembly	1	02-0069

Applies to LW13625 Tong & FARR® Backup Assemblies				
Item	Type	Description	Qty	Part Number
	Assembly	32" - 30K Torque Measurement Assembly	1	10-0022C
A	Part	Compression Load Cell	1	10-0008C
B	Part	30,000 Lbs.-Ft. Gauge, 32" Arm Length (includes following)	1	10-0022G
	Part	1/4" FNPT TEE	1	60-0364
	Part	1/4" NPT Street Elbow	1	08-0023
	Part	1/4" NPT Cap	1	08-0424
C	Part	5 Ft. Hose Assembly	1	02-0069

Compression Load Cell, 8 in ²					
Item	Type	Description	Item	Type	Description
A	Part	5/16" UNC x 1" Hex Socket Head Cap Screw	E	Part	Diaphragm
B	Part	Load Plate	F	Part	Diaphragm Casing
C	Part	5/16" UNC x 3/4" Hex Socket Head Cap Screw	G	Part	Street Elbow
D	Part	Retainer Ring	H	Part	1/4" NPT Brass Plug

This is the standard hydraulic compression load cell supplied by McCoy Drilling & Completions | Farr. Contact our sales department for information about optional application-specific compression load cells.

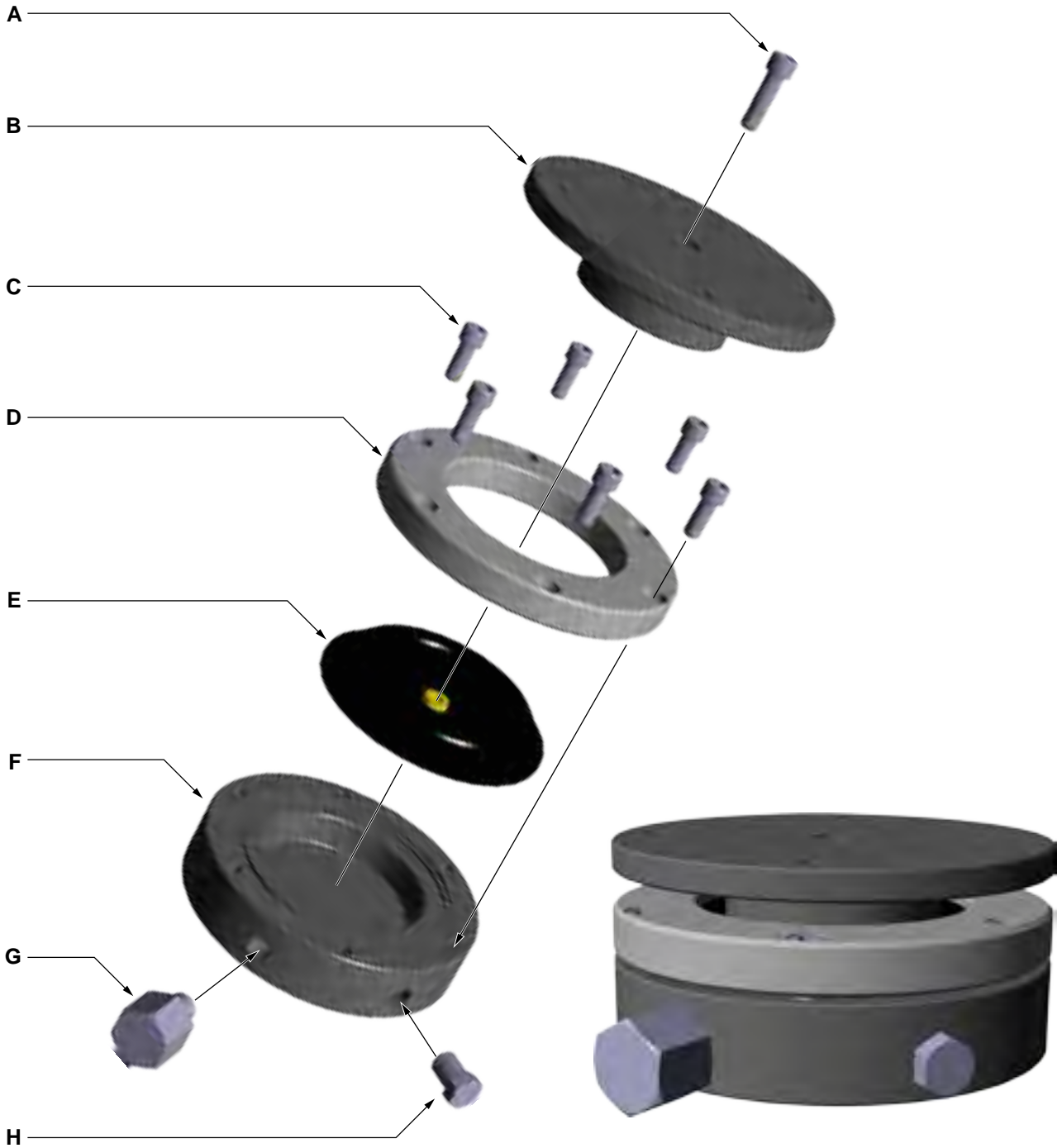
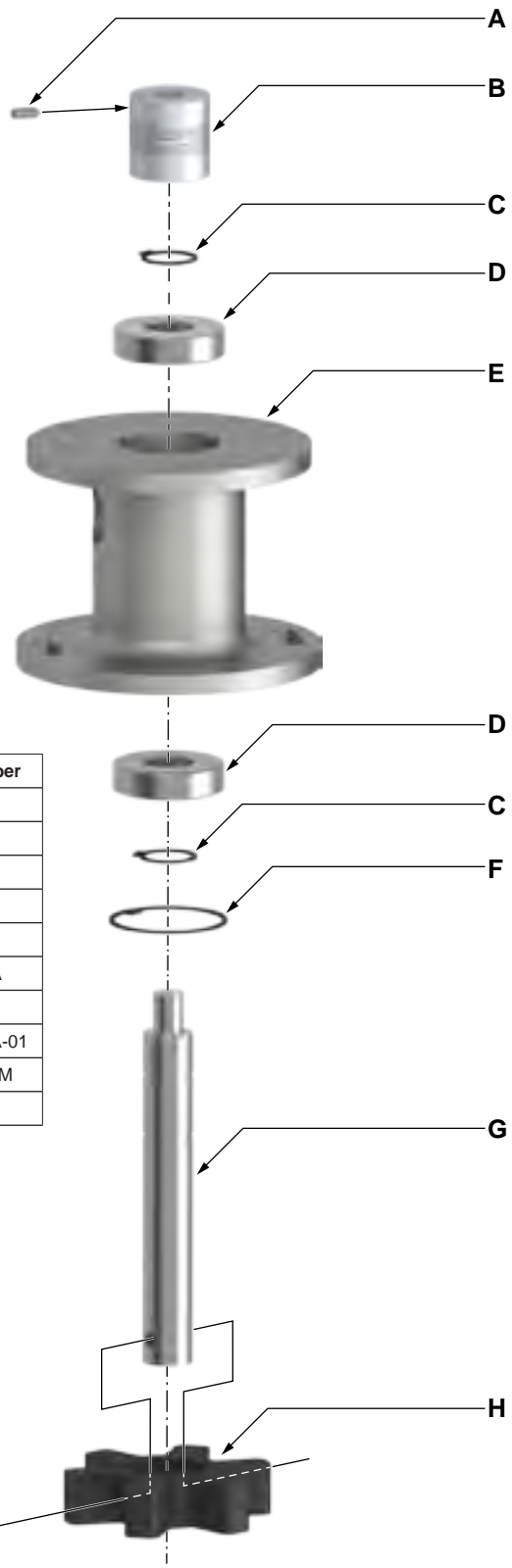
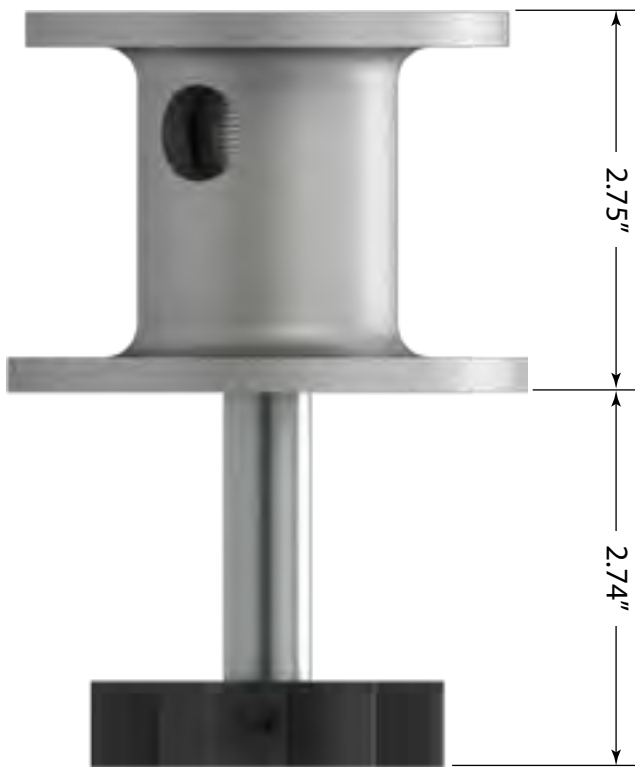

ILLUSTRATION 6.A.4: COMPRESSION LOAD CELL EXPLODED



Item	Type	Description	Qty	Part Number
	Assembly	Standard Turn Counter Encoder Mount	1	60-0001
A	Part	6-32 x 3/8" Hex Socket Head Set Screw	4	
B	Part	Helical Flexible Encoder Shaft Coupling	1	60-0130N
C	Part	Internal Retainer Ring	2	1376-13
D	Part	Bearing	2	1376-05
E	Part	Encoder Housing	1	1392-104A
F	Part	Internal Retainer Ring	1	02-0436
G	Part	Encoder Shaft	1	1392-103A-01
H	Part	Encoder Gear	1	01-0320A-M
J	Part	10-24 x 1-1/4" Hex Socket Head Set Screw	1	

ILLUSTRATION 6.A.5: TURN COUNTER ENCODER MOUNT EXPLODED

B. TROUBLESHOOTING

Under normal operating conditions, and with proper maintenance, the torque gauge and load cell system are designed to give lasting trouble-free performance. Faulty indication on the gauge will very often define a fault within the gauge.



IF TROUBLESHOOTING REVEALS THAT THERE IS INSUFFICIENT FLUID IN THE SYSTEM, BEFORE RECHARGING, CHECK THAT ALL SYSTEM COMPONENTS ARE FREE FROM DAMAGE. THIS WILL ENSURE THAT FLUID LOSS WILL NOT CONTINUE AFTER RELOADING

1. **Symptom: No indication on gauge.**
 - Possible Problem:* Obstruction in hydraulic hose.
 - Solutions:* Check hydraulic hose for kinks.
Replace hydraulic hose.
 - Possible Problem:* Loss of hydraulic fluid.
 - Solution:* Recharge hydraulic fluid (see Section 6.C). NOTE: Ensure any breaches in the hydraulic system between the load cell and torque gauge are repaired to prevent further fluid loss.
 - Possible Problem:* Internal mechanism of torque gauge is damaged.
 - Solution:* Replace gauge.

2. **Symptom: Gauge indication unexpectedly high.**
 - Possible Problem:* Excessive hydraulic fluid.
 - Solutions:* Completely drain hydraulic fluid from torque gauge/load cell system. Recharge following the procedure in Section 6.C.
 - Possible Problem:* Internal mechanism of gauge is damaged.
 - Solution:* Replace gauge.
 - Possible Problem:* Incorrect torque gauge in use (not part of the original torque gauge/load cell pair).
 - Solution:* Replace gauge with gauge properly calibrated for the load cell in service.

3. **Symptom: Gauge indication unexpectedly low**
 - Possible Problem:* Insufficient hydraulic fluid.
 - Solution:* Recharge hydraulic fluid (see Section 6.C). NOTE: Ensure any breaches in the hydraulic system between the load cell and torque gauge are repaired to prevent further fluid loss.
 - Possible Problem:* Obstruction in hydraulic hose.
 - Solutions:* Check hydraulic hose for kinks.
Replace hydraulic hose.
 - Possible Problem:* Snub line not at right-angle to tong handle.
 - Solution:* Check angle of snub line and correct if necessary.
 - Possible Problem:* Internal mechanism of gauge is damaged.
 - Solution:* Replace gauge.
 - Possible Problem:* Incorrect torque gauge in use (not part of the original torque gauge/load cell pair).
 - Solution:* Replace gauge with gauge properly calibrated for the load cell in service.

4. **Symptom: Gauge indication is erratic or sluggish**
 - Possible Problem:* Insufficient hydraulic fluid in torque measurement section.
 - Solution:* Recharge hydraulic fluid (see Section 6.C). NOTE: Ensure any breaches in the hydraulic system between the load cell and torque gauge are repaired to prevent further fluid loss.
 - Possible Problem:* Loss of damping fluid in torque gauge.
 - Solution:* Top up or refill damping fluid (NOTE: Ensure leakage points in gauge are identified and repaired to prevent further loss of damping fluid).
 - Possible Problem:* Air bubbles in hydraulic fluid in the torque measurement system.
 - Solution:* Bleed air from load cell and torque gauge and top up fluid (if necessary) as per Section 6.C.
 - Possible Problem:* Internal mechanism of gauge is damaged.
 - Solution:* Replace gauge.

C. PERIODIC INSPECTION AND MAINTENANCE



ONLY QUALIFIED, DESIGNATED PERSONNEL ARE PERMITTED TO PERFORM MAINTENANCE ON THE TORQUE MEASUREMENT SYSTEM.

1. **Inspection**

The torque measurement system supplied with your equipment is designed and built to provide years of trouble-free service with minimum maintenance. Periodic inspections of the load cell, hydraulic lines and fittings are recommended in order to keep the system in top operating condition. A thorough inspection should be made at each rig-up.

2. **Fluid Recharge**

Recharge hydraulic system with W15/16 fluid through the check valve on the torque indicating gauge. Recharging must only be performed when there is no load on the load cell. Refer to the illustrations on pages 6.3 & 6.4 for guidance if required.

- a. Place the torque indicating gauge higher than the load cell. Remove the brass 1/4" cap from the fitting on the check valve on the top of the gauge.
- b. Connect the hand pump to the check valve fitting.
- c. Elevate the load cell so it is higher than the torque gauge and hand pump.



UN-CONTAINED SPILLAGE OF THE HYDRAULIC FLUID IN THIS SYSTEM MAY CONTRAVENE GOVERNMENTAL ENVIRONMENTAL REGULATIONS, OR THE ENVIRONMENTAL REGULATIONS AND POLICIES OF YOUR COMPANY. FARR CANADA CORP. HIGHLY RECOMMENDS PLACING YOUR LOAD CELL IN A CONTAINMENT BASIN BEFORE PROCEEDING WITH THE BLEEDING & REFILLING PROCESS.

- d. Fill hand pump bowl with W15/16 hydraulic fluid.



MAINTAIN GREATER-THAN HALF FULL FLUID LEVEL IN THE HAND PUMP BOWL TO AVOID PUMPING AIR INTO THE SYSTEM. DO NOT ALLOW THE LEVEL TO FALL BELOW ONE-HALF FULL

- e. Remove the vent plug screw and Stat-O-Seal (Items C and D on Illustration 6.A.4, or item H on Illustration 6.A.5) to allow trapped air to escape.
- f. Pump fluid into the system until no more air is seen escaping from the vent port.
- g. Replace the vent plug screw and Stat-O-Seal and tighten securely.
- h. Remove load cell from containment vessel and wipe clean. Reclaim the hydraulic fluid (if it is clean) or dispose of all waste materials according to governmental or your company's proscribed environmental protection regulations.
- i. Disconnect the hand pump from the torque gauge.
- j. Replace the brass cap on the torque gauge check valve fitting.

3. **Reference Checking Your Torque Measurement System**

The following steps define a process for determining if your torque measurement system is correctly measuring and indicating within an expected range. This procedure is best suited for performing in a shop or location removed from the drill floor, within range of a crane. This is a reference check and not a calibration. Calibrations must be performed at an authorized calibration facility.

Tension Load Cell

- a. Locate a known weight in the range of approximately 500 to 1000 lbs (227 to 455 kg), and move the weight next to the tong and backup assembly.
- b. Remove the tension load cell from the tong, but do not disconnect from the torque gauge.
- c. Suspend the load cell, piston side up, from a crane capable of supporting the known weight in Step 3a.
- d. Connect the rod side of the load cell to the known weight, and use the crane to hoist the weight from the surface to be suspended freely.
- e. Perform a simple calculation to determine the expected indication on the torque gauge based on the known hoisted weight. This is a calculation that must be performed using the arm length expressed in imperial units (feet). The calculation is: [KNOWN WEIGHT] x [ARM LENGTH AS DISPLAYED ON THE TONG PLACARD (in feet)]. For example, if the arm length is 32 inches and the hoisted weight is 1000 lbs the calculation is:

$$1000 \times (32/12) = 2667$$

Therefore, the expected indication on the torque gauge should be 2667 lbs-ft.

Reference Checking Your Torque Measurement System (continued):Tension Load Cell (continued):

- e. Perform a simple calculation (continued):

Calculations for a metric torque measurement system using tension load cell are as follows:

$[\text{KNOWN WEIGHT (in kg)}] \times [2.2] \times [\text{ARM LENGTH INDICATED ON TONG PLACARD}] \text{ (in feet)} \times [1.356]$. For example, if the arm length is 32 inches and the hoisted weight is 500 kg the calculation is:

$$[500] \times [2.2] \times [(32/12)] \times [1.356] = 3977.6$$

Therefore, the expected indication on the torque gauge should be approximately 3980 lbs-ft.

Compression Load Cell

- Locate a known weight, and move the weight next to the tong and backup assembly.
- Remove the compression load cell from the tong, but do not disconnect from the torque gauge.
- Place the compression load cell, piston side down, on a sturdy surface such as a concrete shop floor.
- Use a crane to hoist the known weight on to the rod end of the compression load cell. This is a small area, so an ideal known weight should be relatively small and dense. A block of solid metal or concrete is preferred. The weight must be centered exactly on the rod end of the load cell to ensure even and accurate compression. Do not use a tall unrestrained known weight that could topple. Do not disconnect the known weight from the crane, but ensure the crane exerts no upward force on the weight. The attached crane prevents an un-centered weight from toppling.
- Perform a simple calculation to determine the expected indication on the torque gauge based on the known weight on the load cell. This is a calculation that must be performed using the arm length expressed in imperial units (feet). The calculation is: $[\text{KNOWN WEIGHT}] \times [\text{ARM LENGTH (in feet)}]$. For example, if the arm length is 32 inches and the known weight is 500 lbs the calculation is:

$$[500] \times [(32/12)] = 1333.3$$

Therefore, the expected indication on the torque gauge should be approximately 1333 lbs-ft.

If you are using a metric torque measure system calculations are as follows:

$[\text{KNOWN WEIGHT (in kg)}] \times [2.2] \times [\text{ARM LENGTH (in feet)}] \times [1.356]$. For example, if the arm length is 32 inches and the known weight is 250 kg the calculation is:

$$[250] \times [2.2] \times [(32/12)] \times [1.356] = 1988.8$$

Therefore, the expected indication on the torque gauge should be approximately 1990 Nm.

4. Repair And Calibration

Return the load cell and indicator gauge to the authorized repair facility for repairs and calibration.



***This page intentionally
left blank***



DRILLING &
COMPLETIONS

FARR

Section 7: Hydraulic Component Information

The manufacturer information contained in this section has been obtained from publicly available web sites and has been provided for information purposes only. McCoy Drilling & Completions does not guarantee the accuracy of the information contained in this section. All original copyrights claimed by the manufacturer(s) apply.



15 series

POWER to be the Best!

MOTOR SELECTION GUIDE

**Features of the 15 Series Standard Motor:
Standard Motor - 3000 PSI (Code 61)**

- Eight fixed displacement motors ranging from 6 in³ to 15 in³.
- Starting and stall torques equal to 90-94% of theoretical torque.
- Speed to 2,000 RPM continuous.
- Up to 75 HP continuous.
- Conforms to SAE 'C' mounting specification.
- Weighs 43 lbs.



CROSS SECTION

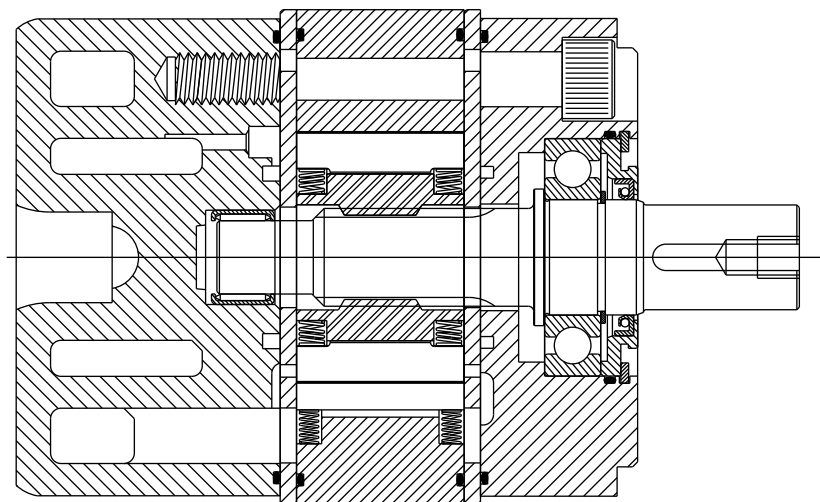

Made in USA



PUBLICATION DS151005 8/03

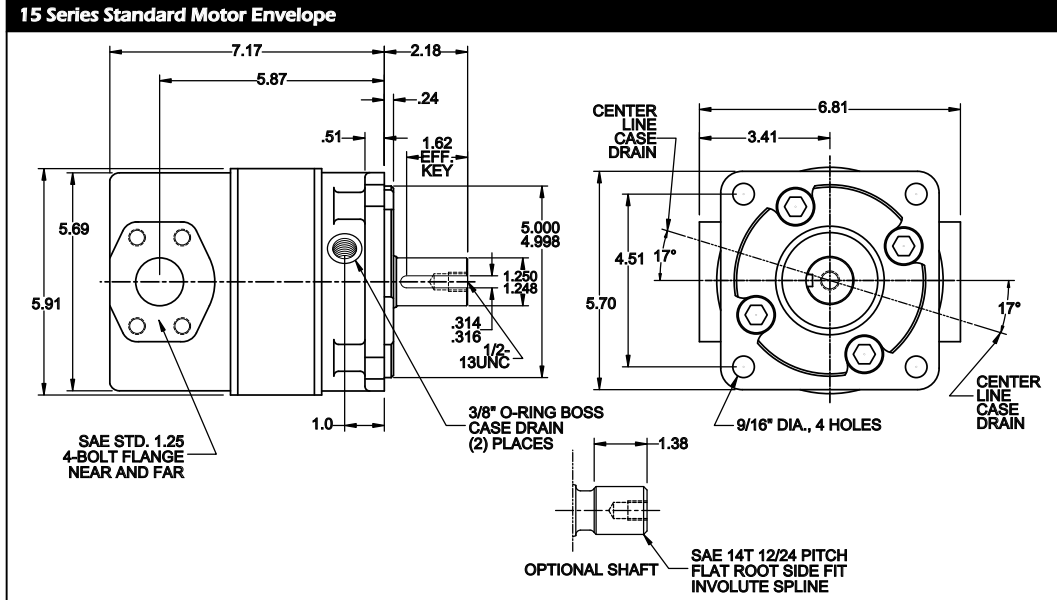

Technical Information - All Styles

VANE CROSSING VANE

The Rineer patented vane crossing vane design produces much higher volumetric and mechanical efficiencies than is possible with a standard vane type design. This design provides a sealing vane between cavities to improve mechanical and volumetric efficiencies.

STARTING AND STALL TORQUE

The Rineer motor produces torque curves which are virtually flat, with starting and stall torque equal to approximately 90-94% of theoretical torque.

MORE POWER STROKES PER REVOLUTION

The 15 Series has four stator cavities and 10 rotor vanes. Each rotor vane works in each stator cavity once per revolution, which results in 40 power strokes per revolution. This helps produce higher mechanical efficiency and flatter torque curves.

BEARING LOADING

The bearings in the 15 Series can accept radial load per the radial capacity chart. Thrust load is not recommended under most conditions. Consult with a Rineer Application Engineer for optional bearing configurations to match your application.

SEALS

Buna N seals are supplied as standard on the Rineer 15 series motors. Viton seals may be ordered as an option.

ROTATING GROUP - 1S or 1H

Under most operating conditions, 1S (standard rotating group parts) should be used. Under some high speed conditions 1H can be specified.

ROTATION

The 15 Series Motor rotates equally well in either direction and smoothly throughout its entire pressure and speed range. Looking into the end of the shaft, rotation is clockwise when oil is supplied to port "A".

HORSEPOWER LIMITATION

Maximum horsepower limitations may vary with different applications. *When using the 15 Series Motor above 75 HP, consult a Rineer Application Engineer.*

FILTRATION

25 micron minimum.

FLUID

We suggest premium grade fluids containing high quality rust, oxidation and foam inhibitors, along with anti-wear additives. For best performance, minimum viscosity should be maintained at 100 SSU or higher. Fluid temperature should not exceed 180° F. Elevated fluid temperature will adversely affect seal life while accelerating oxidation and fluid breakdown. Fire resistant fluids may be used with certain limitations. Contact Rineer for additional information.

CASE DRAIN

The 15 Series Motor is designed for either internal or external case drain. Two case drain ports are supplied. When using internal case drain, simply plug the two ports. When using external case drain, use the port at the highest elevation. We recommend case drain pressure of 35 PSI or less when using the standard seals.

CASE DRAIN CIRCULATION

Fluid should be circulated through the case when a temperature differential exists between the motor and the system in excess of 50° F. *Should this occur, contact a Rineer Application Engineer.*

MOUNTING

The mounting position is unrestricted. The shafts, pilots, and mounting faces should be within .002 TIR.

INTERMITTENT CONDITIONS

Intermittent conditions are to be less than 10% of every minute.

OTHER AVAILABLE MOTORS

For information on additional Rineer Motors, request one of the following publications:

- 37 SeriesPublication DS371003
- 57 SeriesPublication DS571003
- 125 SeriesPublication DS1251003

Performance Data - Selected Displacements

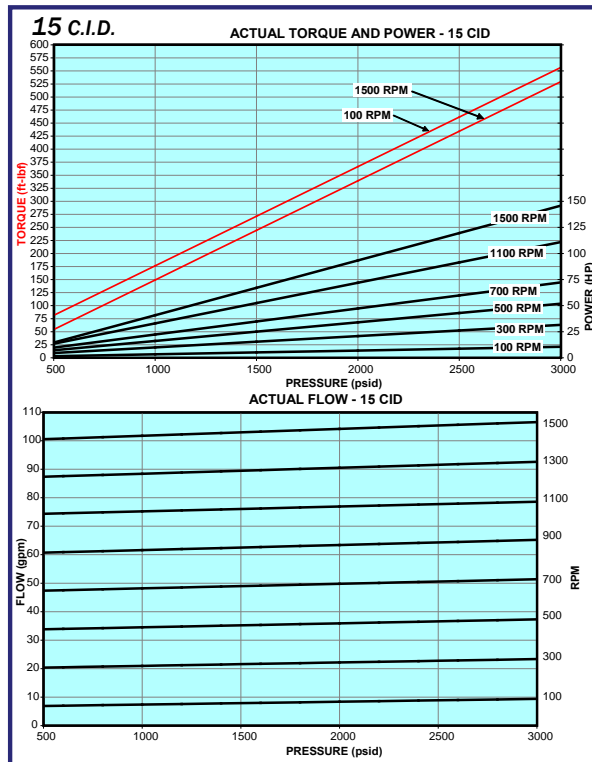
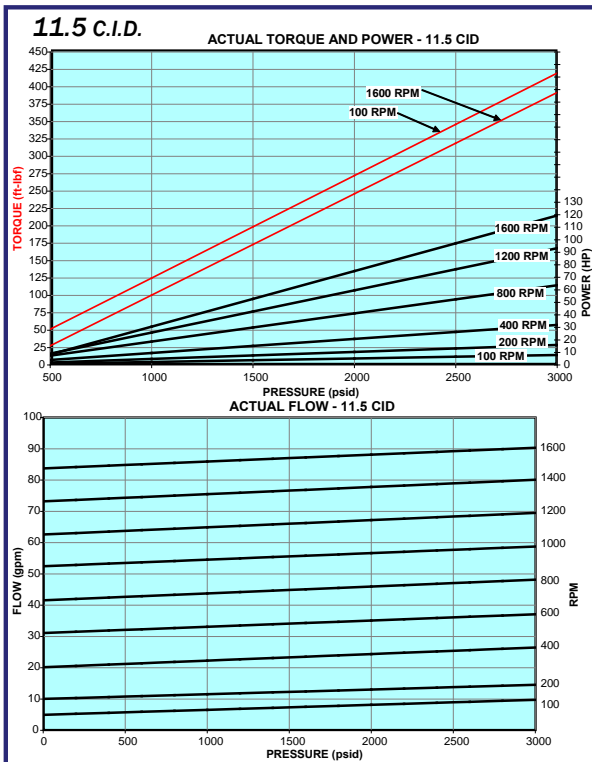
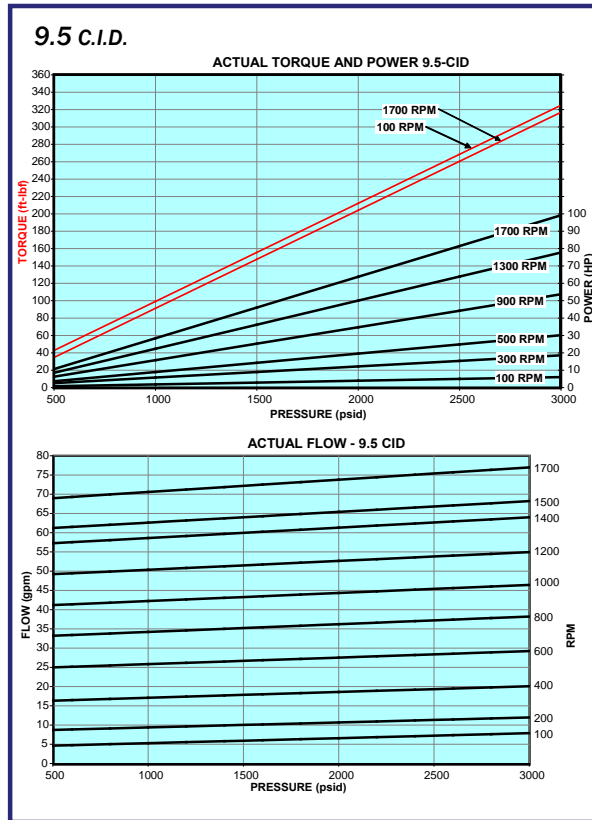
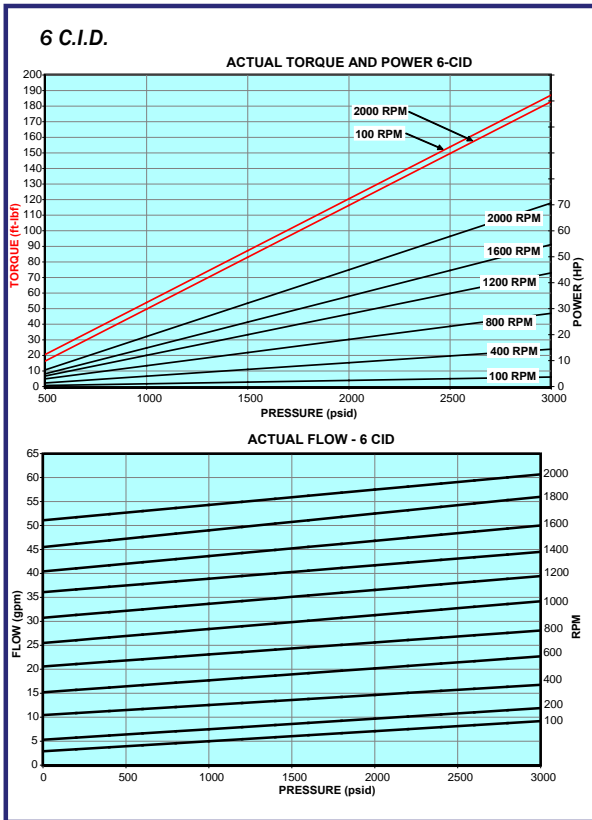

The above performance data was obtained at 140°F with ISO 46(DTE 25). These values must be maintained to obtain the performance indicated. Contact Rineer Hydraulics, Inc. for additional displacements.

Model Code

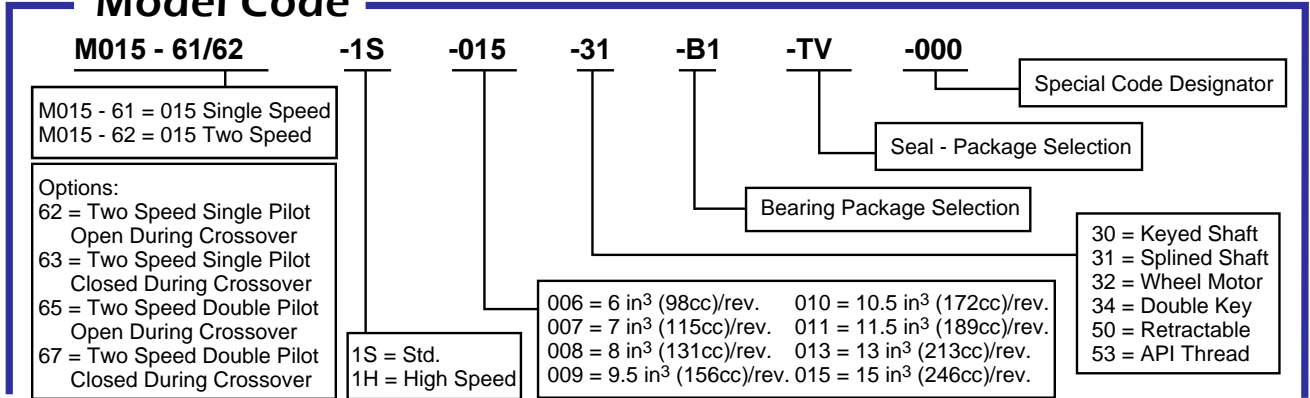

Applications



For durable hydraulic motors that meet your demands, specify Rineer.

For over 35 years, we have specialized in only one thing - engineering the right motor for your needs. Rineer delivers the performance you can count on.

Limited Warranty Policy

Rineer Hydraulics, Inc. warrants that, at the time of shipment to Purchaser, our product will be free of defects in the material and workmanship. The above warranty is LIMITED to defective products returned by Purchaser to Rineer Hydraulics, Inc., freight prepaid within four hundred and fifty-five (455) days from date of shipment, or one (1) year from date of first use, whichever expires first. We will repair or replace any product or part thereof which is proved to be defective in workmanship or material. There is no other warranty, expressed or implied, and in no event shall Rineer Hydraulics, Inc. be liable for consequential or special damages. Dismantling the product, operation of the product beyond the published capabilities or for purposes other than that for which the product was designed, shall void this warranty.





Repair Manual

15 Series



Standard Motor



Two Speed Motor

331 BRESFORT * SAN ANTONIO, TX 78216 * (210) 341-6333 FAX (210) 341-1231

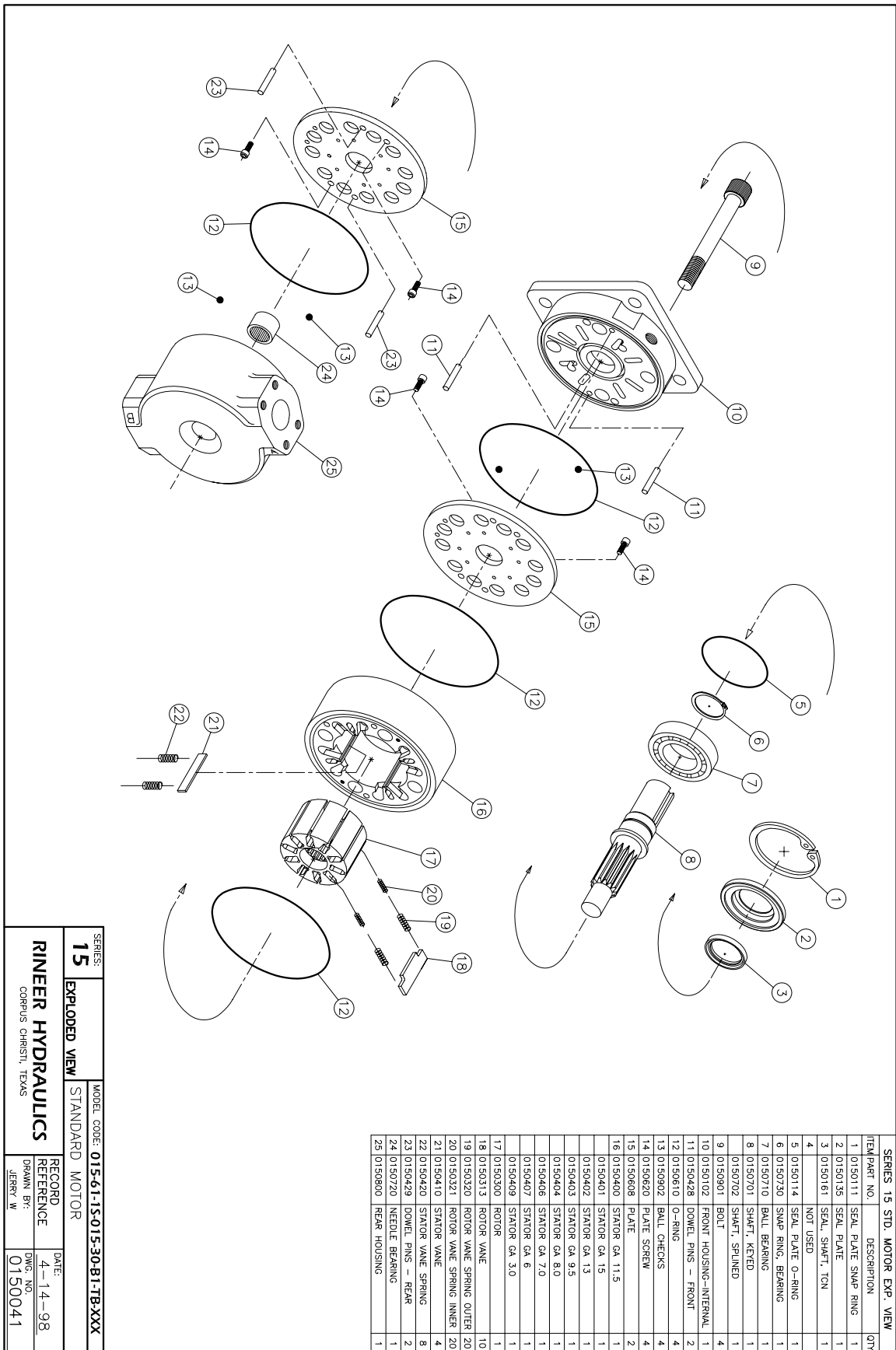

SERIES: 15	MODEL CODE: 015-61-15-015-30-B1-TB-XXX
EXPLODED VIEW	STANDARD MOTOR
RINEER HYDRAULICS	RECORD DATE: 4-14-98
CORPUS CHRISTI, TEXAS	DRAWN BY: DRG NO. 0150041
	CHECKED BY:

WARNING: RINEER RECOMMENDS FOLLOWING ALL STANDARD SHOP SAFETY PRACTICES SPECIFICALLY INCLUDING WEARING OF EYE PROTECTION

REMOVAL OF SHAFT SEAL



1

1) Remove snap ring
WARNING: Use caution when removing snap ring. If released accidentally it can become an airborne hazard.



5

1) Two of the 3/8" bolt holes are provided with jack screw threads.
 2) Insert a piece of 1/4" round stock by 2-1/2" long into each jack screw hole
 3) Screw two 7/16-14 bolts into the jack screw threads until the bearing box is free of the motor.



2

1) Pry out shaft seal plate with two screw drivers.
 2) Remove seal plate o-ring from groove in bearing bore.



6

Lift up on the bearing box to remove from motor.

REMOVAL OF WHEEL MOTOR SEAL PLATE AND BEARING BOX



3

1) Loosen and remove 8 each 10-32 bolts.
 2) Pry off seal plate with screw driver.

DISASSEMBLY OF WHEEL MOTOR BEARING BOX



7

1) Loosen clamp screw in lock nut.
 2) Unscrew lock nut and remove.



4

Loosen and remove 8 each 3/8" bolts with 5/16" socket head wrench.



8

1) Press shaft out of bearing box.
 2) Proceed to step 9, disregarding steps 11 & 12

WARNING: RINEER RECOMMENDS FOLLOWING ALL STANDARD SHOP SAFETY PRACTICES SPECIFICALLY INCLUDING WEARING OF EYE PROTECTION.

DISASSEMBLY OF FRONT HOUSING AND SHAFT



9

- 1) Mark one side of the motor for proper assembly, paying careful attention that the cartridge will not be installed upside down.
- 2) Secure the motor prior to loosening the 5/8-11 bolts.



10

- 1) Remove front housing
- 2) Note: Two 5/16" ball checks and one main body o-ring may be dislodged and fall free.



11

- With the seal plate removed, press shaft and ball bearing out of front housing.



12

- 1) Remove snap ring from shaft.
- 2) Press shaft out of bearing.

DISASSEMBLY OF ROTOR/STATOR CARTRIDGE



13

- Lift up rotor/stator cartridge and remove from the rear housing.



14

- 1) Place cartridge on any object which will hold it off the table.
- 2) Remove two each 10-32 place screws.
- 3) Remove timing plate.



15

- 1) Remove o-ring and springs with a small screwdriver.
- 2) Remove dowels pins.



16

- 1) Replace plate on rotor/stator cartridge.
- 2) Turn rotor/stator cartridge over.
- 3) Repeat steps 14 & 15.

WARNING: RINEER RECOMMENDS FOLLOWING ALL STANDARD SHOP SAFETY PRACTICES SPECIFICALLY INCLUDING WEARING OF EYE PROTECTION.



1) Remove the rotor.
2) Remove both the rotor and stator vanes.
3) Note: On motors manufactured prior to 1987, rotor vane slots and rotor vanes should be numbered so that vanes can be reassembled in the same vane slot.



PLATES: Normal wear results in marking of timing plates which does not impair motor performance. Replacement of the timing plate is required if any smearing, galling, or heat cracks are present.

INSPECTION AND REPLACEMENT OF PARTS



Inspect all springs and seals. We recommend replacement of all seals and springs whenever the motor has been disassembled.



ROTOR: Normal wear results in polishing of rotor faces which does not impair motor performance. Examine the rotor vane slots closely. Polishing down in the slots is normal, but if there is any indication of a "pocket" forming in the wall of the slot, the rotor should be replaced.



Inspect all parts and replace any parts which obviously show excessive wear or damage.



STATOR: Normal wear results in polishing of cam form which does not impair motor performances. Noticeable wear may be apparent along the corner of one side of the stator vane slot. This does not necessarily require replacement of the stator, but may slightly affect volumetric efficiency.

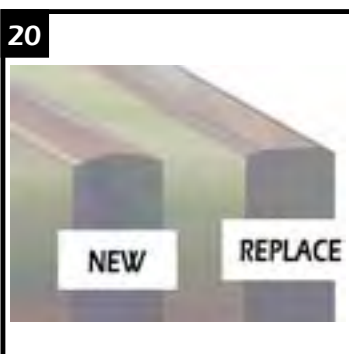

VANES: Normal wear results in slight flattening of vane tips which does not impair motor performance. Replace vane if radius is reduced by 50%. Clearance between the rotor vane and rotor vane slot varies with the vane selection. The design allows the vane to "lean" slightly in the slot, providing the required mechanical seal.



Note: Measure the rotor and stator length to the fourth decimal point and supply measurement when ordering rotor, stator, or vanes.

WARNING: RINEER RECOMMENDS FOLLOWING ALL STANDARD SHOP SAFETY PRACTICES SPECIFICALLY INCLUDING WEARING OF EYE PROTECTION.

ASSEMBLY OF ROTOR/STATOR CARTRIDGE



- 1) Reverse the procedures in steps 17, 16, 15, and 14
- 2) NOTE: Make sure that the radiused edge of each stator vane points to the rotor and the radiused edge of each rotor vane points to the stator.
- 3) NOTE: Make sure springs are seated in the bottom of the spring pocket in both the rotor and stator.

ASSEMBLY OF WHEEL MOTOR FRONT HOUSING



- 1) Reverse the procedures in steps 8 thru 3.
- 2) Screw lock nut onto shaft until all threads are engaged.
- 3) Tighten clamp screw until lock nut turns with a slight drag.
- 4) Tighten lock nut until desired rolling drag of bearing is obtained - see procedure Page 9.
- 5) Tighten clamp screw
- 6) Tighten all seal plate bolts.

ASSEMBLY OF FRONT HOUSING



- 1) Press bearing onto shaft.
- 2) Install snap ring.

ASSEMBLY OF MOTOR



- 1) Install dowel pins into rear housing.
- 2) Install ballchecks into rear housings.
- 3) Install main body o-ring.



- 1) Press shaft and bearing assembly into front housing by pressing on the outer race of bearing.



- 1) Place rotor/stator cartridge onto rear housing.
- 2) NOTE: Make sure assembly marks from step 3 are lined up.



- 1) Place seal in seal plate.
- 2) Place seal plate o-ring into groove in the front housing.
- 3) Press seal plate into front housing.
- 4) Install snap ring.
- 5) Proceed to step 30.



- 1) Install main body o-ring into front housing.
- 2) Install ball checks into front housing.
- 3) Place a small amount of grease over ball checks and o-ring.
- 4) Wipe off excess grease.

WARNING: RINEER RECOMMENDS FOLLOWING ALL STANDARD SHOP SAFETY PRACTICES SPECIFICALLY INCLUDING WEARING OF EYE PROTECTION.



- 1) Install dowel pins into rotor/stator cartridge.
- 2) Pour a small amount of clean oil into the cartridge.
- 3) Install front housing onto rotor/stator cartridge.
- 4) Make sure alignment marks are lined up.



- 1) Rotate shaft in both directions to assure that the shaft turns smoothly.
- 2) Torque motor to 190 ft./lbs.
- 3) Rotate shaft again in both directions to assure that the shaft turns smoothly.



- 1) Install 5/8-11 bolts.
- 2) Torque bolts to 50 ft./lbs.

SPOOL ASSEMBLY FOR THE TWO SPEED MOTOR

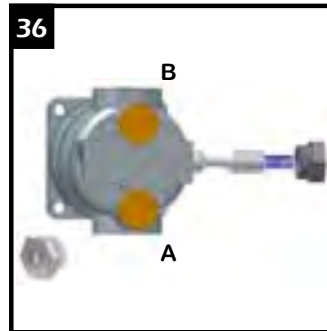

NOTE: Spool should be oriented as shown for two speed motors with model codes 62, 63, 68, & 69.

NOTE: Slight design variations may exist in motors manufactured either before or after the printing of this manual.

WHEEL MOTOR SHAFT AND BEARING ASSEMBLY PROCEDURE

- 1) Clean ALL assembly parts w/ lacquer thinner.
- 2) Dip clampnut and clamping bolt separately in lacquer thinner.
 - (Steps 3 thru 10 must be conducted to completion ONE assembly at a time.)
- 3) Press bearing cups into bearing housing. Make sure they are pressed completely against bearing shoulders.
- 4) Coat inner race of large cone with #609 (green) Loctite and press cone onto the shaft. Make sure the cone is completely against the shoulder of the shaft.
- 5) Insert shaft and large cone into bearing housing.
- 6) Coat inner race of small cone with #609 (green) Loctite and press small cone onto shaft.
- 7) Apply #272 (red) Loctite to the clampnut threads of the shaft. Apply #242 (blue) Loctite to the threads of the clamping bolt and install in the clampnut.
- 8) Spin clampnut onto shaft with the "B" face towards bearings. After the nut threads are fully engaged, but prior to the nut contacting the bearings, □
 - tighten the clamping bolt until there is drag on the clamping nut (see note Fig. 1). Tighten the nut until a 20 to 30 inch pound rolling torque is achieved.
- 9) Tighten clamping bolt on clampnut to 70 inch pounds and recheck rolling torque. Apply inspectors lacquer to head of the bolt.
- 10) Allow a minimum of 24 hrs. to dry.

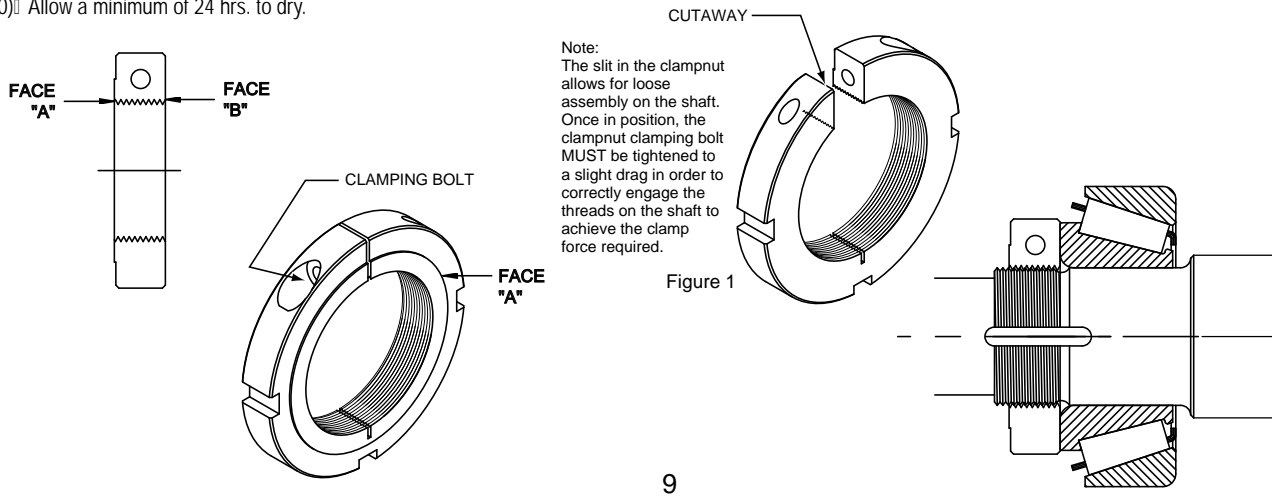

Information:

Bolt Torque -
 Main Bolts (5/8-11): 190 ft. lbs.
 Seal Plate (3/8-16)
 (Wheel Motor only): 45 ft. lbs.
 Grease used for bolt threads
 and o-ring retention:
 Pennzoil 707L RED
 Shaft seal assembly lube:
 Mobilgrease special
 with Moly

Seal Kits:
 Standard 15 series seal kit
 #0150940
 Standard 15 two speed seal kit
 #0150940
 Standard 15 wheel motor seal kit
 #0150936

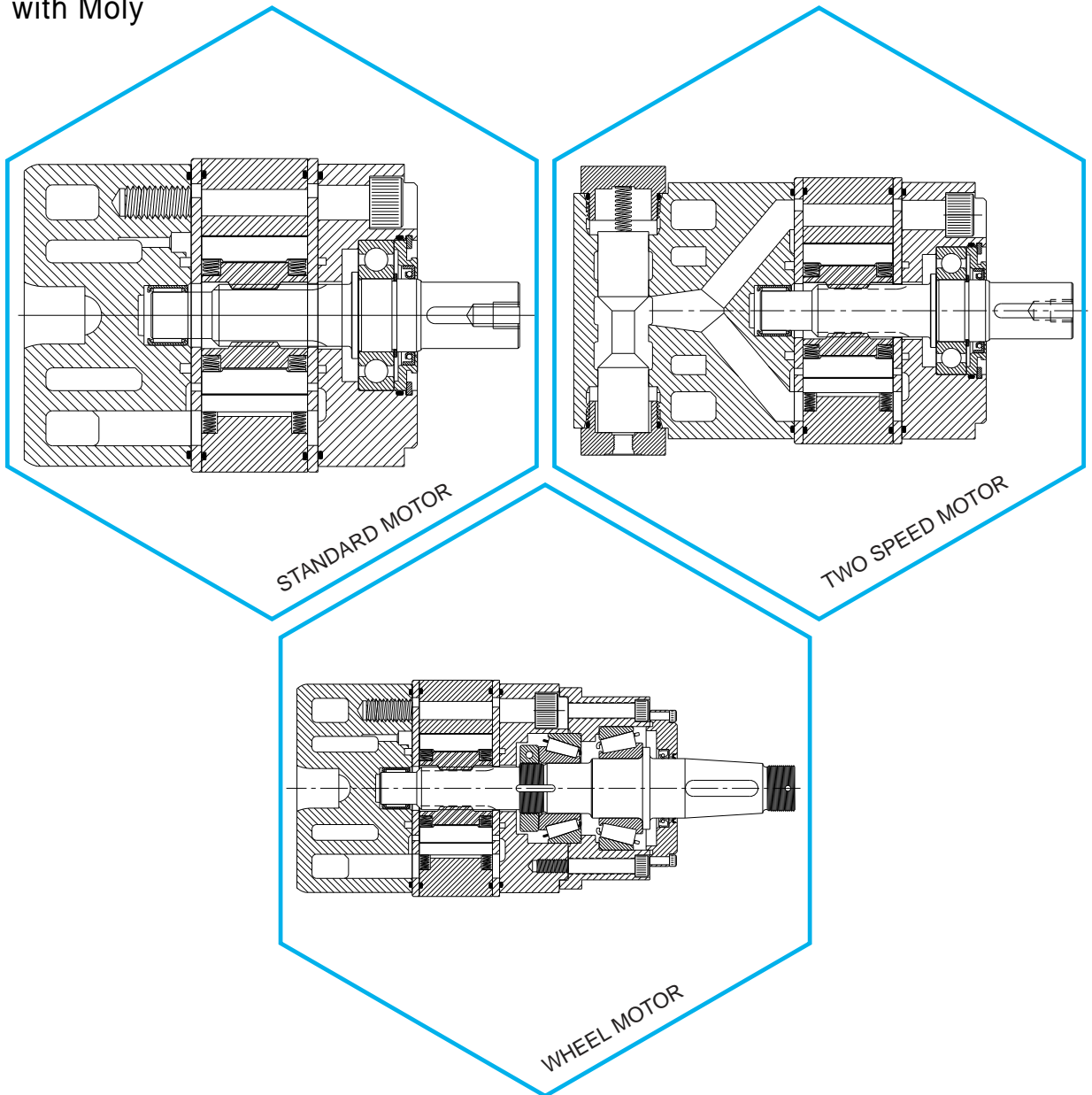

Brief Circuit Descriptions

Series Circuit

Available in DVA20 sections only.

If a machine's work cycle requires simultaneous as well as separate operation of individual hydraulic work functions, a series circuit is right for the job.

As with the other circuits, the oil flows through the open center when all spools are in neutral. There is no parallel passage in standard series sections because they feed directly from the open center passage. If more than one spool is operated, pump flow goes first to the section closest to the inlet. Return flow from the first section is fed back into the open center for use by downstream sections.

Downstream sections can be series, parallel or tandem and will operate in series with the upstream section.

In series circuits, operating pressure is cumulative. Therefore, the sum of the pressures in the circuits can not exceed the circuit or main relief valve setting.

Parallel Circuits

Parallel circuits are the most common on mobile equipment because more than one function can be operated simultaneously and at random. If two or more functions are fully operated at the same time, the one with the lightest load will assert priority because the fluid will take the path of least resistance. However, the operator can divide the flow between functions by metering the spools.

Movement of the spool meters or shuts off the flow of oil thru the open center passage and pressurizes the parallel passage. Oil is then available, at the operator's discretion, to all work ports connected to the parallel passage.

Tandem Circuits

(Not available in the program)

Tandem circuits are sometimes called priority or standard circuits by other manufacturers. Tandem sections feed from the open center passage like series sections but the return flow is directed to the tank return passage and is not available downstream.

If a tandem section is followed by a series or tandem section, operating the tandem section nearest the inlet will assert priority and downstream sections will not function.

Typical Work Section Schematics

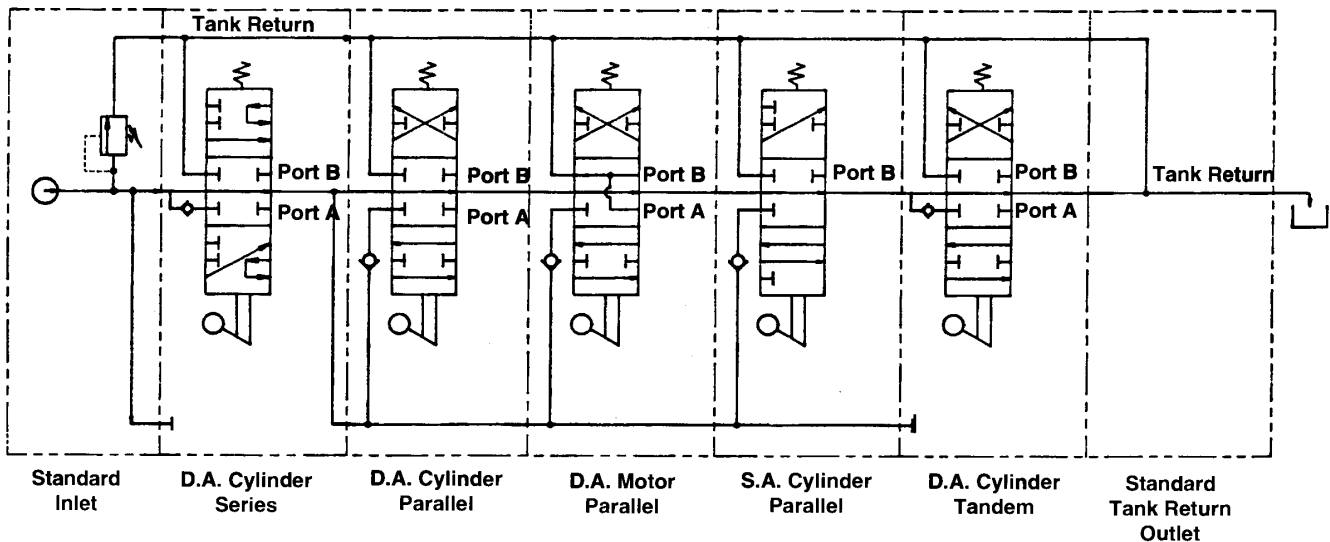

Inlets (2500 psi) End Inlet

Code	End Port	Top Port
DVA35-A440	1" NPT	1" NPT
DVA35-A880	SAE-16	SAE-16
DVA35-A960	SAE-20	SAE-16
DVA35-A000	NON-PORTED HOUSING	

NOTE: Inlets are machined for a main R/V or R/V plug and are furnished with plastic closures. See Section G, Page 32 for inlet port plugs.



Schematic shown with main R/V



Note: For inlets with solenoid section pilot supply machining, see DVA35 inlet section E t

Adjustable Relief Valve Cartridges For Inlets and Mid-section Inlets

Code	Description
DVA35-MRV-1	Main R/V pressure range 800-2000 psi. Factory set @ 1500 psi @ 50 gpm
DVA35-MRV-2	Main R/V pressure range 2001-2500 psi. Factory set @ 2500 psi @ 50 gpm.
DVA35-MRVP	Main relief valve plug



Outlets

Tank Return Type

Code	End Port	Top Port
DVA35-TR55	1 1/4" NPT	1 1/4" NPT
DVA35-TR99	SAE-20	SAE-20
DVA35-TR00	NON-PORTED HOUSING	

NOTE: See Section G, Page 32 for Port Plugs

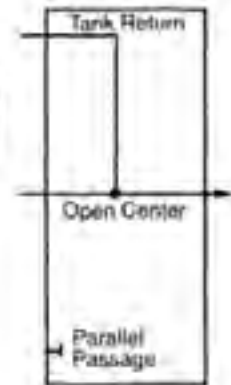

Pressure Beyond Type

	End Port LP	End Port HP	Top Port LP	Top Port HP
DVA35-PB55	1 1/4" NPT	1 1/4" NPT	1 1/4" NPT	1 1/4" NPT
DVA35-PB90	SAE-20	SAE-20		
DVA35-PB09			SAE-20	SAE-20
DVA35-PB00	NON-PORTED HOUSING			



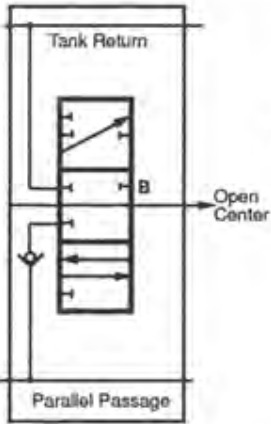

SA8
Single-Acting Section
3-Way, 3-Position, Hold in Neutral
Cylinder Spool

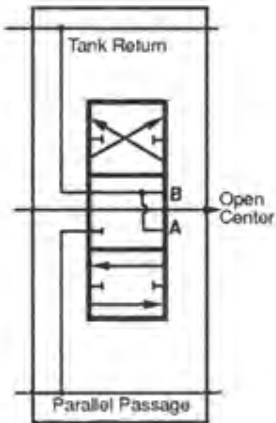

MA8
Double-Acting Section
4-Way, 3-Position, Float in Neutral
Motor Spool

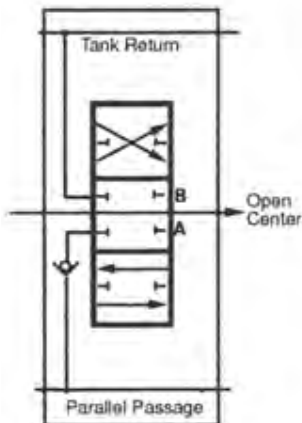

DA8
Double-Acting Section
4-Way, 3-Position, Hold in Neutral
Cylinder Spool



Lo-Boy Work Sections -- Parallel Circuits

Code	1 Way 2 Position Lead In Sealed	2 Way 2 Position Lead In Sealed	3 Way 2 Position Lead In Sealed	3 Way & Pressure Flow Position Sealed	1/2" NPT Inlet	Work Port NPT Multifunction	Spring Return	3 Position Select	Intermittent Flow with Throttle Control	Intermittent Operation	AC 240		
DVA35-DA0	*					*	*						
DVA35-DA4	*				1" NPT		*						
DVA35-DA8	*				SAE-16		*						
DVA35-SA0		*				*	*						
DVA35-SA4		*			1" NPT		*						
DVA35-SA8		*			SAE-16		*						
DVA35-MA0			*			*	*						
DVA35-MA4			*		1" NPT		*						
DVA35-MA8			*		SAE-16		*						
DVA35-DK8-12V	*				SAE-16					12 VDC			
DVA35-DK8-24V	*				SAE-16					24 VDC			
DVA35-DX4	*				1" NPT			*					
DVA35-DX8	*				SAE-16			*					
DVA35-DV4	*				1" NPT						*		
DVA35-DV8	*				SAE-16						*		
DVA35-MX4			*		1" NPT			*					
DVA35-MX8			*		SAE-16			*					
DVA35-OB4	*				1" NPT			*					
DVA35-OB8	*				SAE-16			*					
DVA35-SB4		*			1" NPT			*					

Note: See Section G, Page 33 for section seal kits.
 Codes outside of the shaded area may require increased lead time.
 Most codes outside the shaded area can be made from codes inside the area and kits on page 33.
 Solenoids are furnished with spade connectors.
 Machining instructions for standard housings are included in solenoid kits.

VA™/VG™ Valve Service Instructions

INTRODUCTION

This manual has been prepared to assist you in the proper maintenance of the VA20™/VA35™ and VG20™/VG35™/VG80™ directional control valves. Before any work is done, we suggest that you read the assembly and disassembly instructions completely.

The first rule of good maintenance is cleanliness, which includes a clean environment. **MAKE SURE YOU DISASSEMBLE AND ASSEMBLE YOUR HYDRAULIC EQUIPMENT IN A CLEAN AREA.** Dirt is the natural enemy of any hydraulic system.

GENERAL INFORMATION

The VA and VG model valves are updated versions of our proven A20™ and A35™ units. The VG models are cast from compacted graphite, a high strength iron alloy, which allows the valve to be rated to 3500 psi. VA models are cast from gray iron and are rated at 2500 psi. These open-center, directional-control valves are available in parallel, tandem, and series circuitry. As needed, the sectional, stack-type construction provides flexibility for the addition or subtraction of work sections to an existing valve bank. This design also permits the combination of parallel, tandem, and series circuitry in a single bank. The internal coring of each valve section determines its circuitry and the number of gasket seals required.

All sections with optional features, such as port relief valves, crossover relief valves, and anti-cavitation checks, are dimensionally larger when measured from the top of the port to the bottom of the housing. These are referred to as "hi-boy" sections. Those without work-port options can use the low-profile castings, which are called "lo-boy" sections.

REPLACEMENT PARTS

The illustrations and instructions in this manual apply only to the VA/VG series assemblies, subassemblies, and components. All valve components, except for spools and housings, are available as replacement parts or subassemblies. Spools are hone-fitted to their individual housings, so damage to either of these components means the entire section must be replaced.

We recommend that you use only genuine VA/VG series replacement parts in your service program. Manufactured to the same exacting tolerances and quality controls as the original equipment, genuine VA/VG replacement parts may help prevent premature component failure and costly downtime. Service parts and assemblies are available through your original equipment dealer or any authorized distributor.

MAINTENANCE

Valves are often used in hazardous environments. Inspect them frequently for damage due to improper use, corrosion or normal wear. If needed, repairs should be made immediately.

Always refer to the machine manual for the proper procedure to remove the valve from the machine.

Remove the valve bank from the equipment, disconnecting all hoses, fittings, control handles and linkage connectors that might be attached to the valve. Plug all ports and thoroughly clean the exterior of the valve bank, then the port plugs can be removed.

Exploded View of Work Section

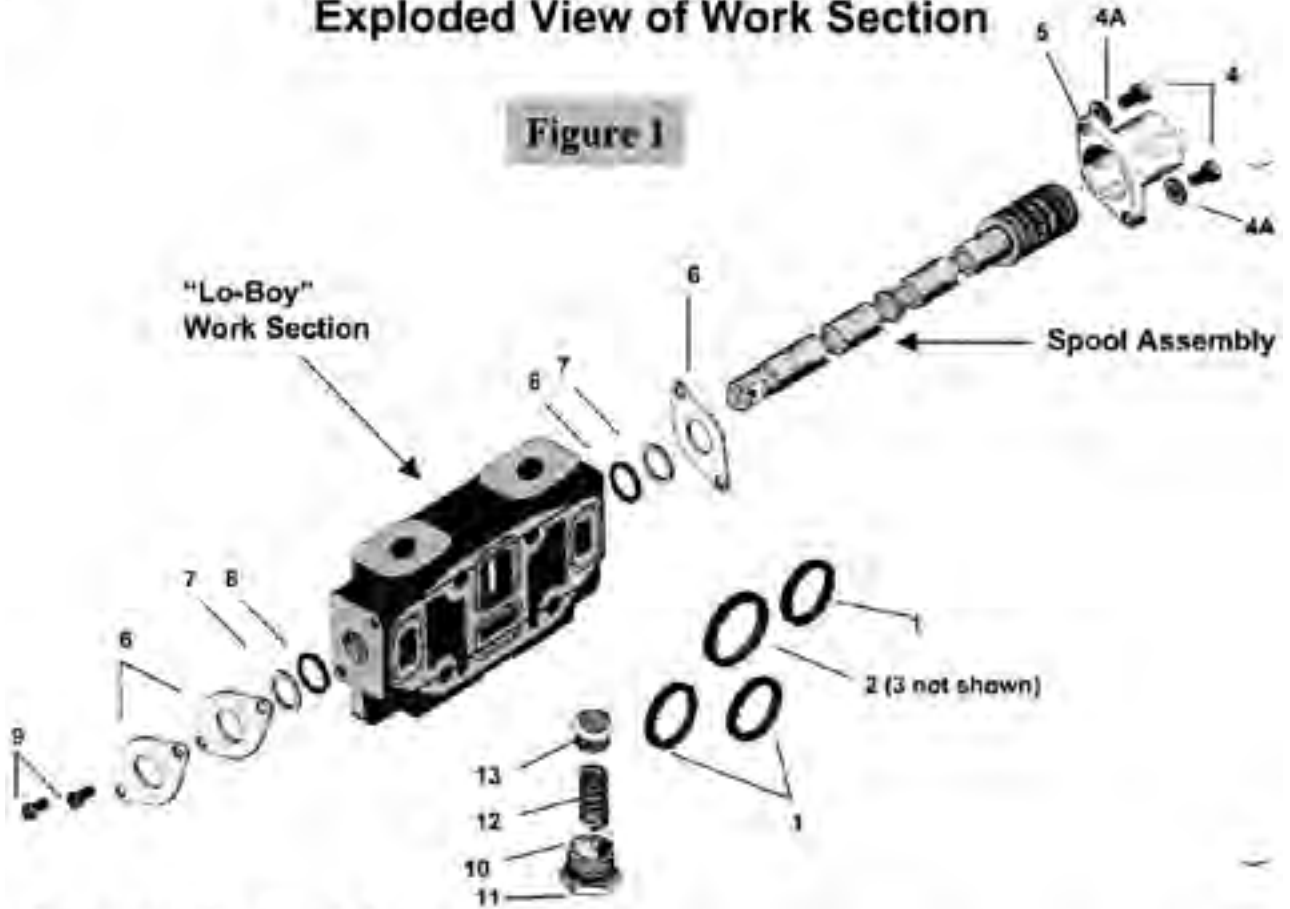

Figure 1

Parts List For Work Section

Item	Description	Qty.	VA/VG20 Part No.	VA/VG35 Part No.	VG80 Part No.
Parallel Section Seals* See Figure 1					
1.	Square Seals	3	391-2881-206	391-2881-200	391-2881-433
2.	Square Seal	1	391-2881-200	391-2881-403	391-2881-670
Series Section Seals					
1.	Square Seals	2	391-2881-206	391-2881-200
3.	Square Seal	1	391-2881-627	391-2881-628
Parallel and Series Section Component Parts. See Figure 1					
4.	Back Cap Screws	2	391-1433-020	391-1433-009	(4) 391-1402-068
4A.	Lock washers	8	391-3783-039
5.	Back Cap	1	341-6000-100	342-6000-100	341-0585-099
6.	Retainer Plates	3	391-2183-001	391-2183-005	391-2183-157
7.	Back up Rings	2	391-2681-378	391-2681-426	391-2681-285
8.	Spool Seats	2	391-1985-014	391-2887-212	391-2681-096
9.	Retainer Plate Screws	2	391-1433-015	391-1433-002	(4) 391-1402-015
10.	Check Valve Cap	1	391-0561-044	391-0561-044	391-0585-099
	Or Valve Cap (F.I.N.)	1	391-2261-015	391-2261-015
11.	O Ring Seal **	1	391-2881-204	391-2881-204	391-2881-249
12.	Check Spring **	1	391-3581-713	391-3581-713	391-3581-778
13.	Check Valve Poppet **	1	391-2461-069	391-2461-069	391-2383-091

*Parallel Sealing Face includes inlets and mid-inlets.

**Not required in Float-in-neutral Sections.

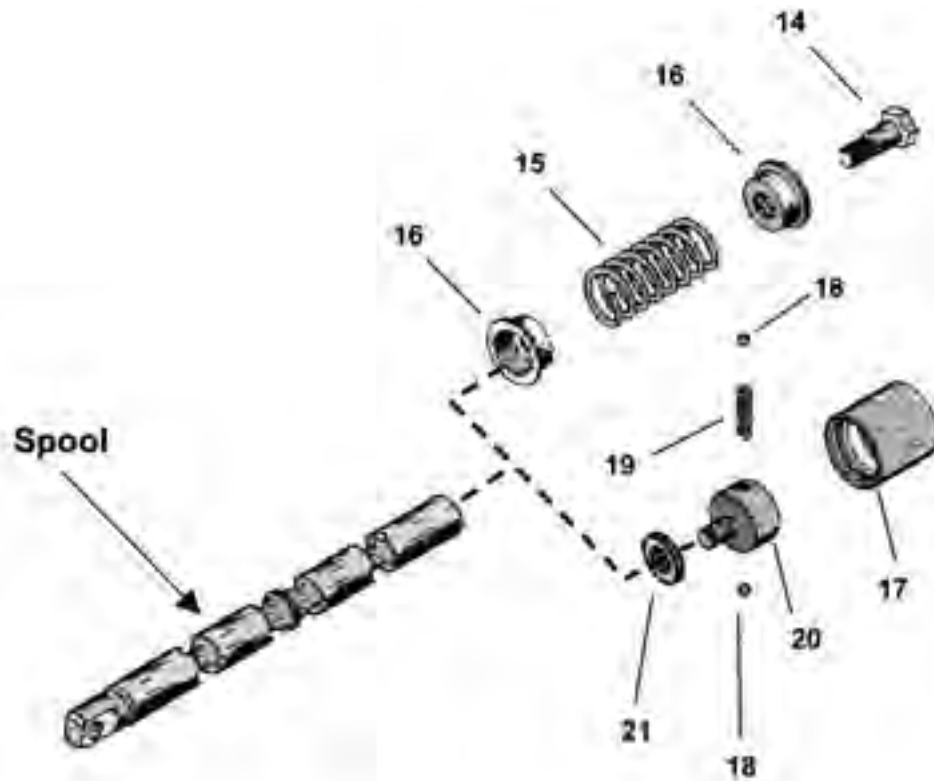

Spring Centered and Detent Spool Operators. See Figure 2

14.Stripper Bolt	1	391-1432-022	391-1432-021	391-1402-452
15.Centering Spring	1	391-3581-608	391-3581-633	391-3581-330
16.Spring Guides	2	391-1642-045	391-1642-013	391-1642-161
17.Detent Sleeve	1	391-3283-015	391-3283-008	391-3384-310
18.Detent Balls	2	391-0282-010	391-0282-009	391-0282-011
19.Detent Spring	1	391-3581-130	391-3581-015	391-3581-316
20.Detent Poppet Retainer	1	391-2583-008	391-2583-006	391-3384-311
21.Detent Spacer	1			391-3782-208

4

Valve Disassembly Instructions

Reference exploded view and parts list on page 2 and 3 for work section detail.

Step 1 - Valve Bank

This step is the most critical in the disassembly procedure. It should be followed closely to ensure that the valve bank is properly reassembled after repairs have been made.

With a waterproof, quick-drying marker, mark each casting with a sequential number. Start by marking the inlet casting with the #1 and finish by marking the outlet with the highest number.

Next, mark the port boss closest to the back cap on each work section with a "B" (for back cap end).

Then, mark the port boss closest to the spool clevis on each work section with a "C" (for clevis end).

Finally, if relief valves are removed from the valve bank they must be marked with the corresponding number of the casting and port location (B or C) from which they were removed. Inlet and mid-inlet relief valves are marked with a casting number only.

Step 2 - Tie Bolts

Remove the four tie bolts that hold the bank together and separate the sections.

NOTE: VA valve tie bolts thread into the outlet casting. VG valve tie bolts pass through the entire bank, requiring washers and hex nuts to be fastened at both ends of the bolt.

Step 3 - Section Seals

The inlet, mid-inlet and each parallel work section have two section seals: (Fig. 1, items 1 & 2) on the downstream mating face. Series work sections and the VA/VG35 qd/c flow mid inlets have three section seals on the downstream mating face; (Fig. 1, items 1 & 3). These section seals should be removed and discarded.

REMINDER: ALL WORK MUST BE PERFORMED IN A CLEAN AREA.

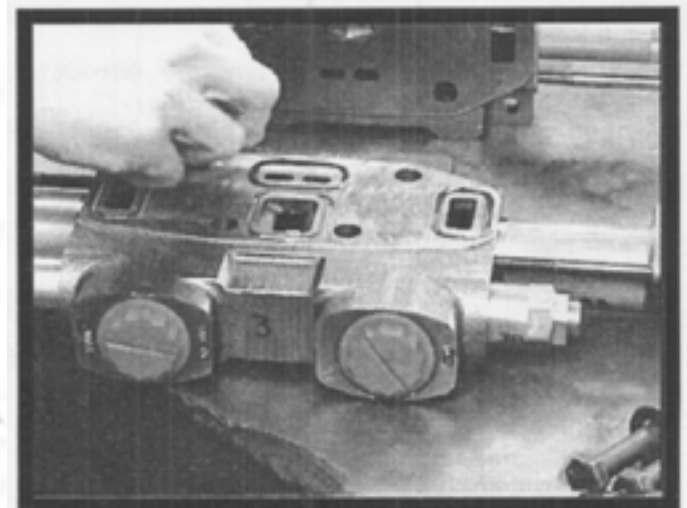
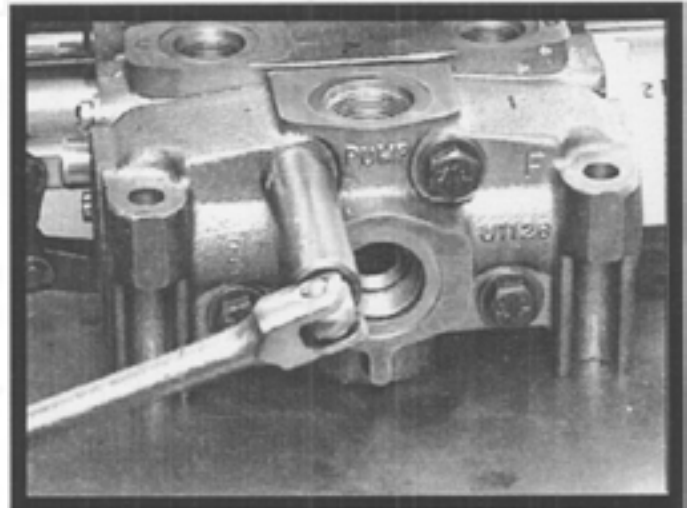
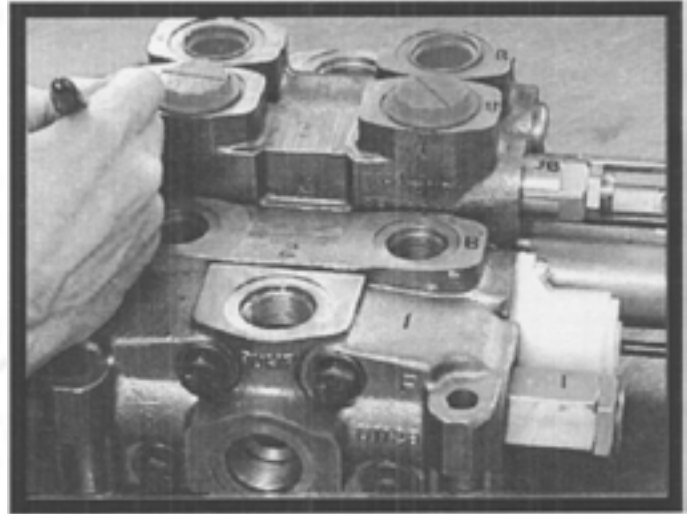

Valve Disassembly Instructions

5

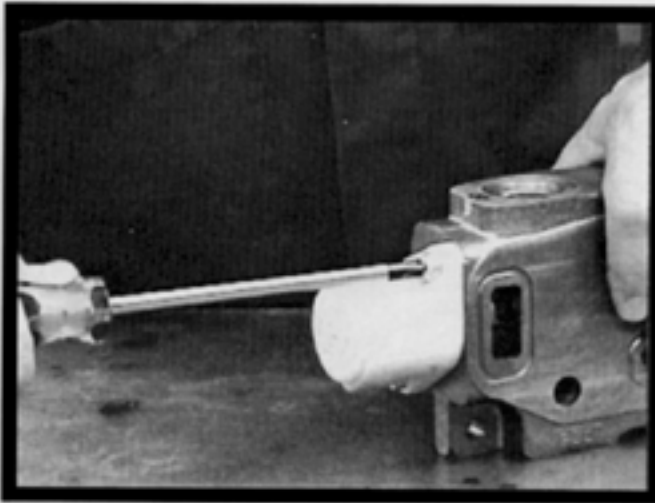

Step 4 - Valve Back Cap

Using a large, Phillips-head screwdriver, remove the two, cap screws (Fig. 1, item 4) which fasten the back cap to the work section. Lightly tap the end of the screwdriver handle with a hammer to break adhesive. Remove the back cap (Fig. 1, item 5).



Step 5 - Control Spool and Seals

Grasp the spring end of the spool with a clean, lint-free cloth and pull the spool out of the housing using a twisting motion. Generally, the rear, retainer plate (Fig. 1, item 6) back-up ring (Fig. 1, item 7) and spool seal (Fig. 1, item 8) will come out with the spool.

CAUTION: For detented spool models, be careful not to remove the detent poppet sleeve (Fig. 2, item 17) unless it is to be serviced.

Using a large, Phillips-head screwdriver, remove the two, retainer-plate screws (Fig. 1, item 9) from the spool clevis end of the work section. Lightly tap the end of the screwdriver handle with a hammer to break the adhesive. Remove the two, retainer plates (Fig. 1, item 6) the back-up ring (Fig. 1, item 7) and the spool seal (Fig. 1, item 8). Tap or mark with the appropriate, work section identification number (See Step 1.) Spool seals (Fig. 1, item 8) and back-up rings (Fig. 1, item 7) should be discarded.

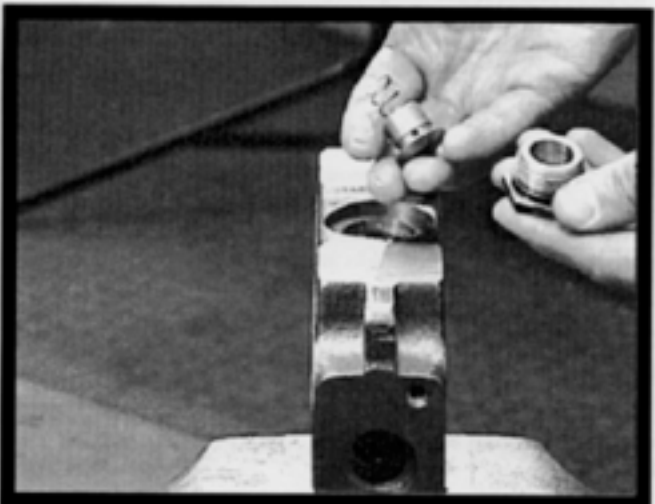

Step 6 - Transition Check

The transition check is located in the bottom center of the work section housing. Carefully clamp the work section in a vise with ports down. Do not clamp on the machined surface. Remove the check-valve cap (Fig. 1, item 10) and its O-ring seal (Fig. 1, item 11). Discard the seal. Remove the check spring (Fig. 1, item 12) and the check-valve poppet (Fig. 1, item 13).

NOTE: Only cylinder work sections (ports blocked in neutral) have a transition check. Motor sections have only a cap plug.

6

Valve Disassembly Instructions

Spool Disassembly

Spring Centered Spool

The spring assembly should not be removed from the spool unless these parts need to be replaced. Once the spool is free of the work section housing, it must be handled carefully to avoid damage. Place the spool vertically in a soft-jawed vise, clamping on the flat spool clevis, and remove the stripper bolt (Fig. 1, item 14) with a wrench.

Lightly tap the stripper bolt with a hammer and a punch to help break the adhesive. Cautious application of heat may be required to free the stripper bolt, since an anaerobic thread adhesive was used during its assembly.

CAUTION: Too much heat may distort the spool.

As the stripper-bolt threads disengage, the spring (Fig. 2, item 15) and spring guides (Fig. 2, item 16) will release abruptly from the spool.

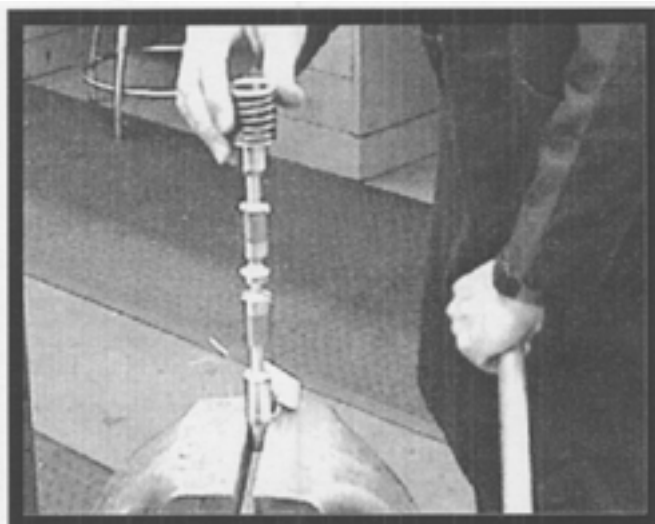

Detent Spool

The detent assembly should not be removed from the spool unless these parts need to be replaced. Wrap the detent sleeve (Fig. 2, item 17) with a clean, lint-free cloth. Grip the cloth-covered sleeve and pull firmly. As the sleeve moves backwards, the detent balls (Fig. 2, item 18) and the detent spring (Fig. 2, item 19) will release abruptly. The cloth should capture these parts and prevent their loss.

Next, clamp the spool in a soft-jawed vise and remove the detent poppet retainer (Fig. 2, item 20). Place an undersized bar through the detent ball bore to serve as a wrench. Lightly tap the detent poppet retainer with a hammer and a punch to help break the adhesive. Cautious application of heat may be required again, since an anaerobic adhesive was also used to the detent retainer assembly.

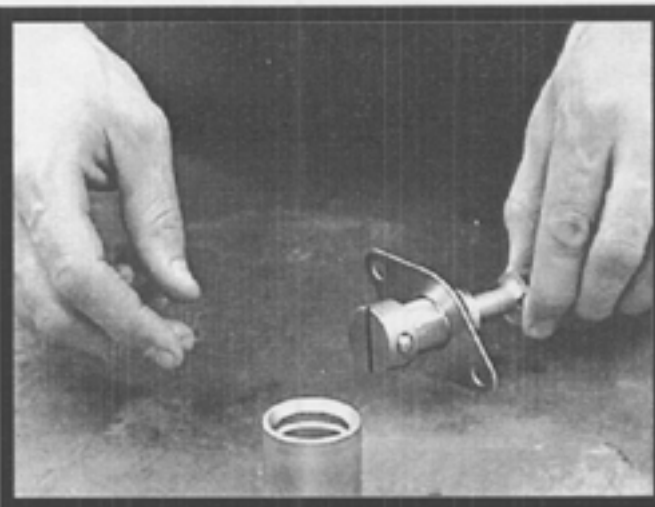

CAUTION: Too much heat may distort the spool!

CLEANING, INSPECTION, AND REPAIR

1. Inspect the spool bore, transition check seat and spool from each section for deep scratches, gouges or excessive wear. If any of these conditions exist, replace the section. Minor, surface damage on the control spool and check poppet can be carefully polished away with a very fine, canvas cloth.

2. Examine the machined surfaces of the valve housing for nicks and burrs that could cause leakage between sections. Lightly stone these surfaces to remove any rough spots.

CAUTION: A shallow-milled relief area extends across the O-ring face of the valve housing. This should not be stoned or ground off!

3. Wash all parts thoroughly in a cleaning solvent and blow dry before beginning reassembly. Pay special attention to the number and letters marked on the parts in Step 1. If any marks are removed during cleaning, re-mark immediately.

4. Clean adhesive from threads of spool, stripper bolt, housing, cap screws and hex nut with Loctite™ Chisel Gasket Remover.

Valve Assembly Instructions

7

Preparation of Parts

Spray the threads of the new stripper bolt (Fig. 2, item 14) tapered-threaded spool end, all screws and screw holes on both ends of the housing with LOCTITE Primer Grade NPT™ and let dry.

CAUTION: Failure to follow the recommended assembly instructions can result in poor performance or product malfunction. Product should be thoroughly tested to ensure proper operation before the valve is placed back into service.

Spring Center Spool Assembly

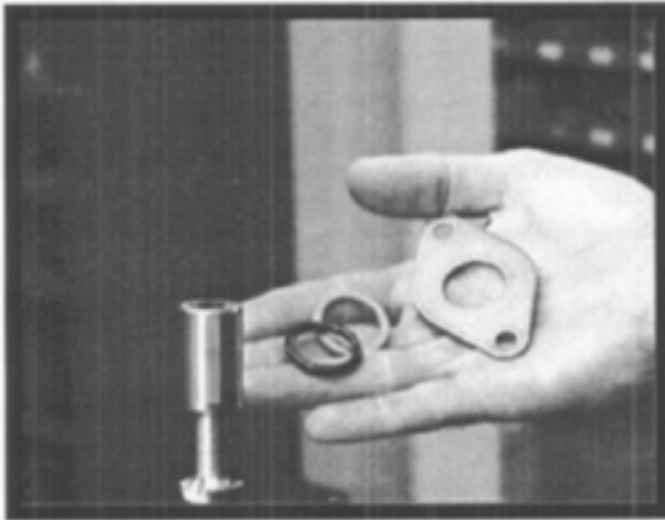

Step 1 - Spool Assembly-Spring Centered

Clamp the flat, clevis end of the control spool in a soft jawed vise. Apply Parker Super-O-Lube™ to the spool seal (Fig. 1, item 8) and slide it onto the end of the spool away from the clevis. Slide on the back-up ring (Fig. 1, item 7) and retainers plate (Fig. 1, item 6). Position these items onto the spool, so that they do not interfere with the spool operator mechanism during assembly. Do not allow the O-ring to come in contact with the sharp edge of the spool notches.

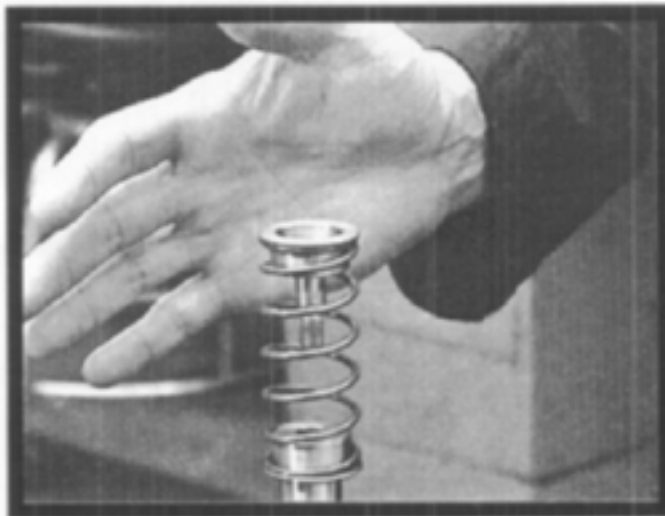

Step 2 - Attach Spring Guides and Spring

Apply 2-3 drops of Loctite 262™ or equivalent anaerobic adhesive near the middle of the female threads in the spool. Assemble the spring guides (Fig. 2, item 6) centering spring (Fig. 2, item 15) and stripper bolt (Fig. 2, item 14) onto the spool (Reverse of Step 7). Torque the stripper bolt to 175 in. lbs. +/-4 in. lbs.

CAUTION: Care must be taken to ensure that the spring retainer is not pinched under the shoulder bolt during assembly. This can result in burrs that may cause spool binding. Check for binding by compressing the spring and guides or by rotating the spring guide nearest the housing.

CAUTION: Follow the adhesive manufacturer's instructions for proper cleaning and curing. Failure to clean and prepare parts properly may result in assembly failure!

Lightly coat the centering spring with high-temperature grease to prevent rusting. Set the spool assembly aside and let it cure for a minimum of 1 hour. After curing, test the stripper bolt to make certain it can withstand 125 in. lbs. of breakaway torque.

8

Valve Assembly Instructions

Detent Spool Assembly

Step 1 - Spool Assembly-Detent

Apply Parker Super-O-Lube™ to the spool seal (Fig. 1, item 8) and slide it onto the spool. Slide the back-up ring (Fig. 1, item 7) and one retainer plate (Fig. 1, item 6) onto the spool. Position these items onto the spool, so that they do not interfere with the spool operator mechanism during assembly. Do not allow the O-ring to come in contact with the sharp edge of the spool notches. Apply 2-3 drops of Loctite 262™ or an equivalent, anaerobic adhesive near the middle of the female threads in the spool.

CAUTION: Follow the adhesive manufacturer's instructions for proper cleaning and curing. Failure to clean and prepare parts properly may result in assembly failure.



Step 2 - Spool Assembly-Detent

Thread the detent ball retainer (Fig. 2, item 20) into the spool end. Torque the detent ball retainer to 175 in. lbs. (4 in. lbs.). This can be accomplished by using a crow-foot socket on the flats of the clevis, and holding the spool by inserting a round, steel rod or screwdriver through the hole in the ball retainer.

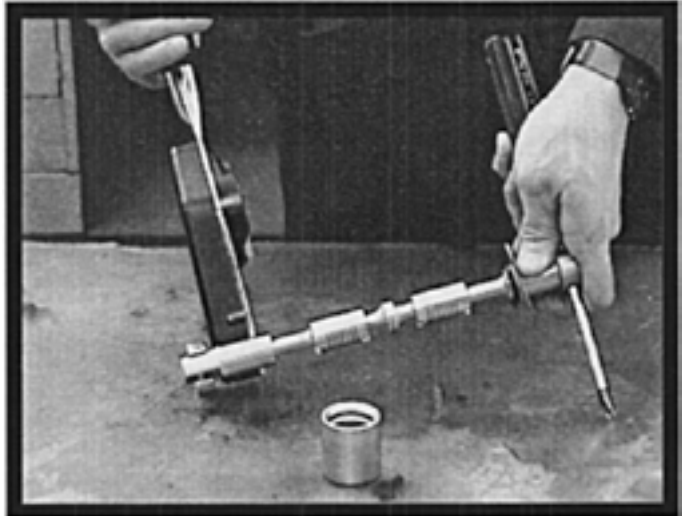

Step 3 - Detent Balls and Spring

Next, lightly coat the detent balls (Fig. 2, item 18) detent spring (Fig. 2, item 19) and entire inside diameter of the detent sleeve (Fig. 2, item 17) with high-temperature grease.

Insert the detent spring into the through hole in the detent ball retainer. Place the steel balls on the ends of the spring. Compress the balls and spring, then slip on the detent sleeve. (Note: The detent sleeve is not symmetrical, one end of the sleeve has a lead-in chamfer. This chamfer must face the spool clevis when assembled.) Move the detent sleeve to the neutral or middle position to prevent the subassembly from separating during subsequent steps.

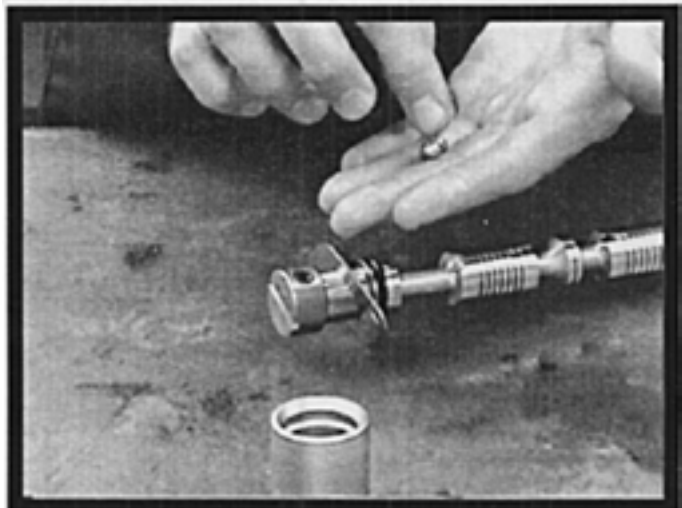

Valve Assembly Instructions

9

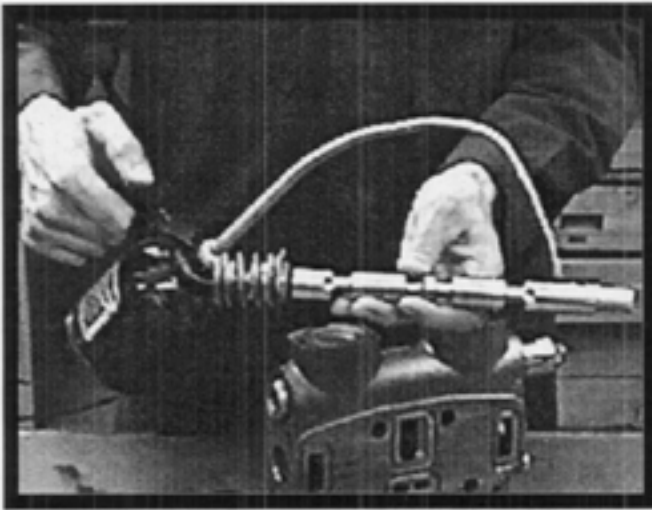

Step 1 - Spool Subassembly

Apply 2 - 3 drops of Loctite 262™ or equivalent to the fillister screw holes on both ends of the housing.

Apply a light coating of clean, hydraulic oil to the valve spool. Carefully insert the spool assembly into the housing. Use caution to avoid causing burrs. Be careful not to pinch, roll or damage the seals. Make sure that the spool and housing are in the proper orientation (see Step 1, page 6 disassembly).

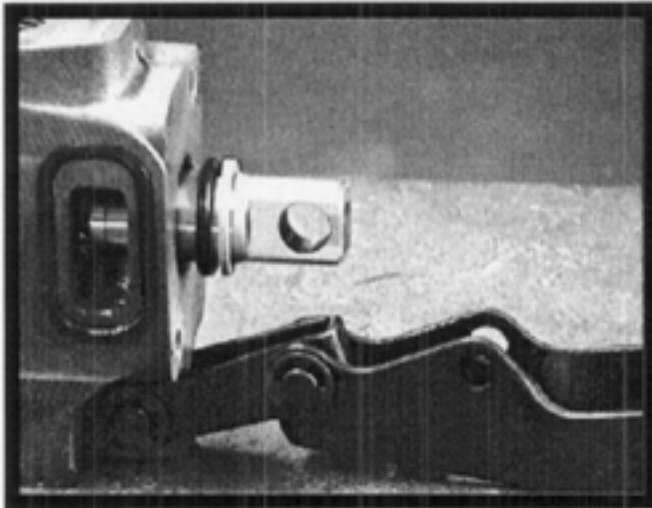

Step 2 - Spool Seal and Back up

Apply Parker Super-O-Lube™ to the spool seal (Fig. 1, item 8) and slide it onto the spool. Slide on the back-up ring (Fig. 1, item 7). Push both items into the counter-bore until they bottom out.

Assemble the two front retainer plates (Fig. 1, item 6) using the two short fillister screws (Fig. 1, item 9). Check retainer plates for proper alignment. Tighten to a final torque of 34 in. lbs. \pm 2 in. lbs.

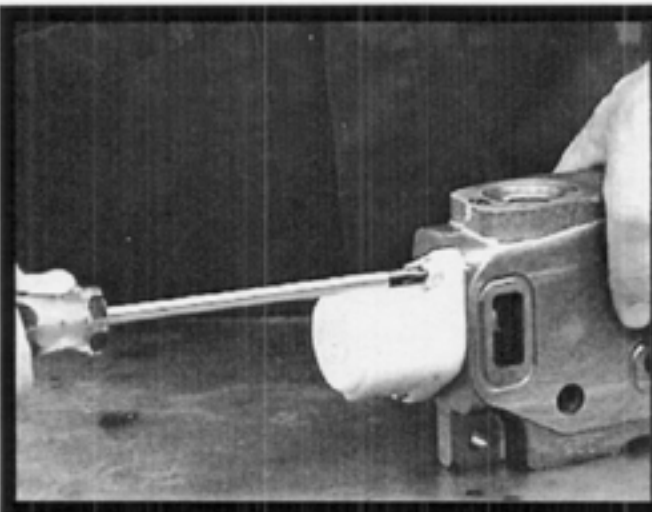

Step 3 - Back cap

Install the back cap using the two long fillister screws (Fig. 1, item 4). Tighten to a final torque of 34 in. lbs. \pm 7 in. lbs.

Caution: Excessive torque will damage the back cap ears!

Valve Assembly Instructions

Step 4 - Install Transition Check

Inspect transition check components for cleanliness. Install check poppet (Fig. 1, item 13) into the transition check cavity. Align the check spring (Fig. 1, item 12) square to the poppet, then carefully place the check cap (Fig. 1, item 11) over the poppet and spring. Turning by hand, engage several threads. Tighten to a final torque of 75 ft. lbs. (100 in. lbs.).

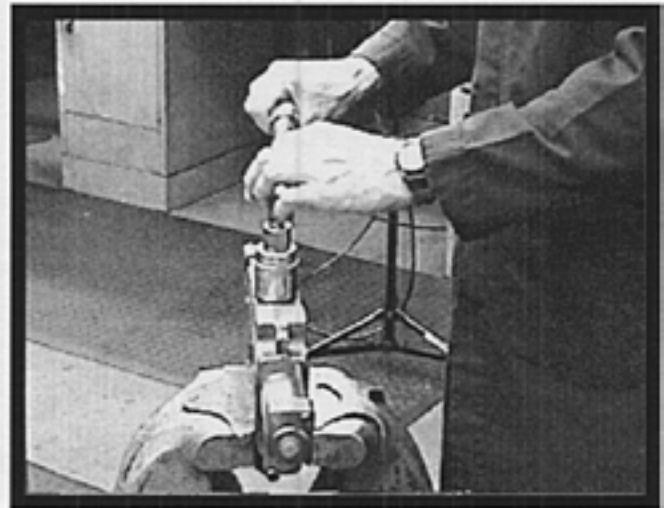

Step 5 - Relief Valves

Return all relief valves to their proper positions and torque to 75 ft. lbs.

Install new section seals. Place section seals (Fig. 1, items 1 & 2, or items 1 & 3) in the proper grooves. Make certain seals stay in their grooves during assembly.

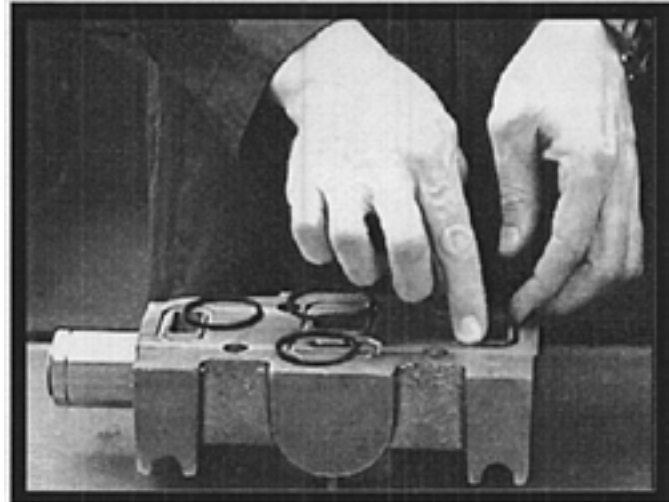

Step 6 - Install Tie Bolts

Slide the tie bolts through the inlet casting. If cap screws are used, place a washer on the cap screw prior to installation. Place the valve sections on the tie bolts in their proper sequence (see Step 1, page 4). Turning by hand, engage several threads in the outlet. If it is a VG-series assembly, assemble nut and washer to either end of the stud and follow above instructions. Torque the tie bolts in a cross-corner pattern.



Tie Bolt Torque Values

VA20 - 29 ft. lbs. (348 in. lbs.)

VG20 - 42 ft. lbs. (504 in. lbs.)

VA35 - 34 ft. lbs. (408 in. lbs.)

VG35 - 75 ft. lbs. (900 in. lbs.)

VG80 - 150 ft. lbs. (1800 in. lbs.)

28

Troubleshooting

TROUBLE	PROBABLE CAUSE	REMEDY
Oil leaks between sections	Pinched, blown or missing section seal	Replace section seal
	Stud fasteners not correctly torqued	Replace section seals and re-torque
	Mounting plate not level	Loosen mounting bolts and shim as required
	Contamination/burrs on seal	Clean seal groove, replace section seal
Oil leaks at either end of spool	Over-pressurized tank core	Correct high, back-pressure condition
	Worn or damaged spool seals	Replace seals and seal retainers
Spring - centered spools do not return to neutral	Broken centering spring	Replace centering spring
	Misalignment of operating linkage	Check linkage for mechanical binding
	Foreign particles in system	Clean valve and system
Load will not hold	Cylinder leaking or worn	Check cylinder - repair
	Port relief valve not holding	Remove and clean or replace
	Spool or housing scored or worn excessively	Replace section
Load drops when spool moved from neutral	Dirt or foreign particles lodged between check-valve poppet and seat	Disassemble, clean & reassemble
	Scored or sticking check-valve poppet	Replace poppet
No motion, slow, or erratic system operation	Worn pump	Check flow & pressure
	Defective cylinder or motor	Repair or replace
	Low-reservoir oil level	Add oil to specifications
	Clogged suction strainer	Clean or replace
	Suction line restricted	Check lines
	Relief valve not properly set	Check pressure setting
	Relief valve poppet or seat scored & sticking open	Replace relief valve
	Valve spool not shifted to full stroke	Check spool linkage travel

Pilot-to-open, spring biased closed, unbalanced poppet logic element

Capacity:
60 gpm (240 L/min.)

Functional Group:

Products : Cartridges : Corrosion Resistant : Logic Element : Unbalanced Poppet, Pilot-to-open, Switching Element, Spring biased closed, External Pilot Port 3 pilot source

Model:
LKHC

Product Description

These unbalanced poppet, logic valves are 2-way switching elements that are spring-biased closed. Pressure at either work port 1 or 2 will further bias the valve to the closed position while pressure at port 3 will tend to open it. The force generated at port 3 must be greater than the sum of the forces acting at port 1 and port 2 plus the spring force for the valve to open. NOTE: The pilot area (port 3) is 1.8 times the area at port 1 and 2.25 times the area at port 2.

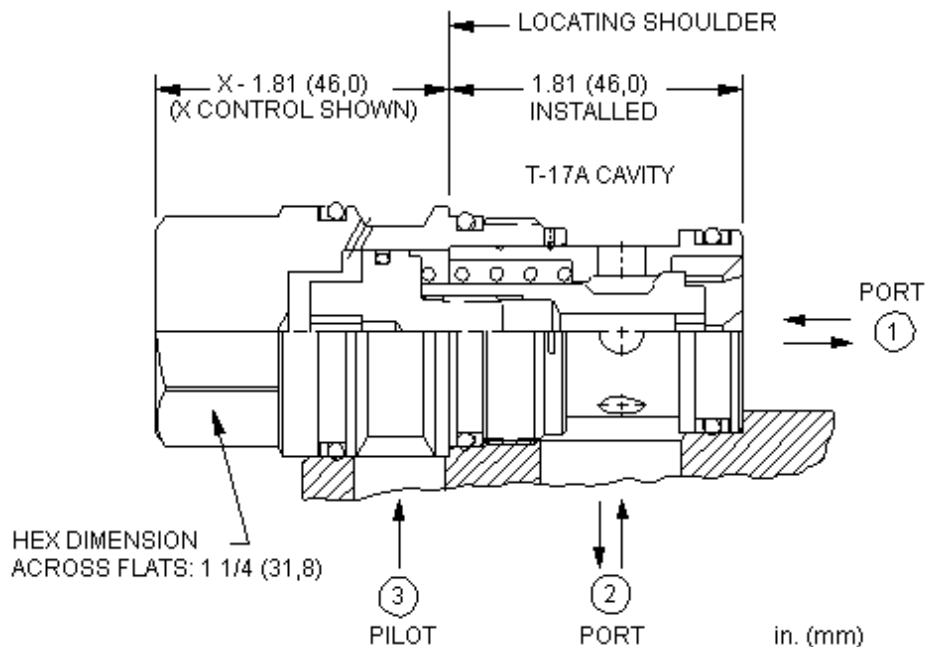
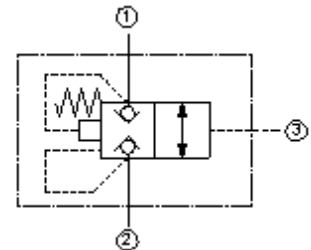

Technical Features

- Because these valves are unbalanced, operation is pressure dependent. Opening and closing of the poppet are functions of the force balances on three areas: 1) Port 1 = 100%, Port 2 = 80%, and Port 3 = 180%.
- These valves are pressure responsive at all three ports, therefore it is essential to consider all aspects of system operation through a complete cycle. Pressure changes at any one port may cause a valve to switch from a closed to an open position, or vice versa. All possible pressure changes in the complete circuit must be considered to assure a safe, functional system design.

- These valves have positive seals between port 3 and port 2.
- Incorporates the Sun floating style construction to eliminate the effects of internal parts binding due to excessive installation torque and/or cavity/cartridge machining variations.
- Stainless steel cartridge options P or W are intended for use within corrosive environments with all external components manufactured in stainless steel or titanium. Internal working components remain the same as the standard valves.

Technical Data

	U.S. Units	Metric Units
Cavity	T-17A	
Capacity	60	240 L/min.
Area Ratio, A3 to A1	1.8:1	
Area Ratio, A3 to A2	2.25:1	
Maximum Operating Pressure	5000	350 bar
Maximum Valve Leakage at 110 SUS (24 cSt)	10	10 drops/min. @70 bar
Pilot Volume Displacement	.15	2,5 cc
Series (from Cavity)	3	
U.S. Patent #	4,795,129	
Valve Hex Size	1 1/4	31,8 mm
Valve Installation Torque	150 - 160	200 - 215 Nm
Seal Kits	Buna: 990-017-007	
Seal Kits	Viton: 990-017-006	

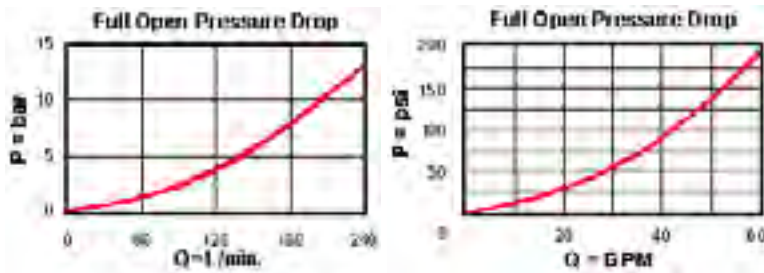

Option Selection

LKHC-X D N



Preferred Options

Control

Cracking Pressure

External Material/Seal Material

Standard Options

X Not Adjustable

N Buna-N
V Viton

Pilot operated, balanced piston relief valve

Capacity:
25 gpm (95 L/min.)

Functional Group:

Products : Cartridges : Relief : 2 Port : Pilot Operated, Balanced Piston

Model:
RPEC-LAN

Product Description

Pilot-operated, balanced-piston relief cartridges are normally closed pressure regulating valves. When the pressure at the inlet (port 1) reaches the valve setting, the valve starts to open to tank (port 2), throttling flow to regulate the pressure. These valves are accurate, have low pressure rise vs. flow, they are smooth and quiet, and are moderately fast.

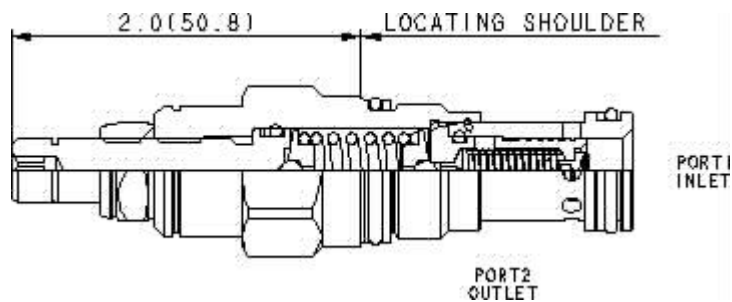
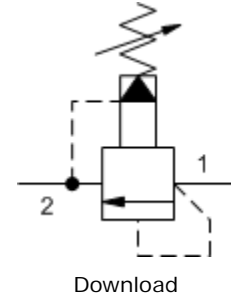

Technical Features

- Will accept maximum pressure at port 2; suitable for use in cross port relief circuits. If used in cross port relief circuits, consider spool leakage.
- Not suitable for use in load holding applications due to spool leakage.
- All 2-port relief cartridges (except pilot reliefs) are physically and functionally interchangeable (same flow path, same cavity for a given frame size).
- Incorporates the Sun floating style construction to minimize the possibility of internal parts binding due to excessive installation torque and/or cavity/cartridge machining variations.
- Main stage orifice is protected by a 150 micron stainless steel screen.
- Back pressure on the tank port (port 2) is directly additive to the valve setting at a 1:1 ratio.
- Stainless steel cartridge options P or W are intended for use within corrosive environments with all external components manufactured in stainless steel or titanium. Internal working components remain the same as the standard valves.

Technical Data

	U.S. Units	Metric Units
Model Weight	0.30 lb.	0.14 kg.
Cavity	T-10A	
Capacity	25 gpm	95 L/min.
Adjustment - Number of Clockwise Turns to Increase Setting	5	
Factory Pressure Settings Established at	4 gpm	15 L/min.
Maximum Operating Pressure	5000 psi	350 bar

Maximum Valve Leakage at 110 SUS (24 cSt)	2 in ³ /min.@1000 psi 30 cc/min.@70 bar	
Response Time - Typical	10 ms	
Series (from Cavity)	Series 1	
Valve Hex Size	7/8 in.	22,2 mm
Valve Installation Torque	30 - 35 lbf ft	45 - 50 Nm
Adjustment Screw Hex Socket Size	5/32 in.	4 mm
Adjustment Nut Hex Size	9/16 in.	15 mm
Adjustment Nut Torque	108 lbf in.	12 Nm
Seal Kits	Buna: 990-010-007	
Seal Kits	Viton: 990-010-006	

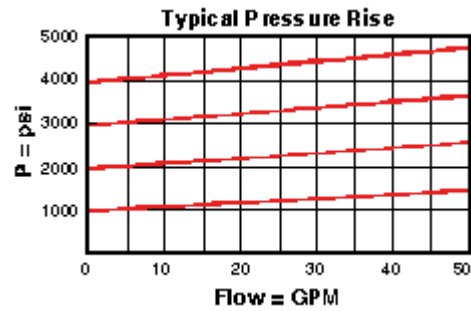
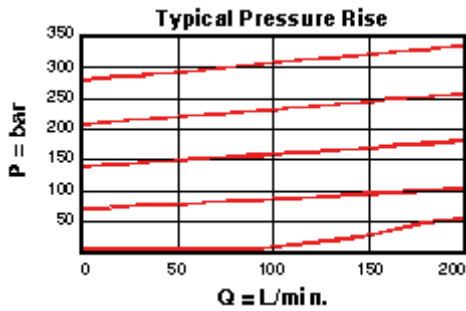
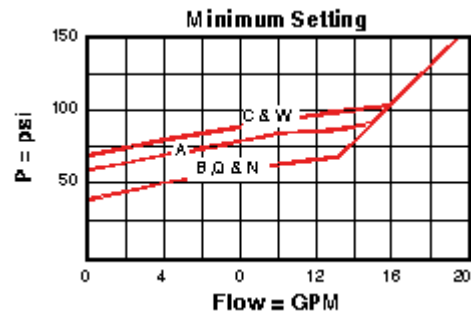
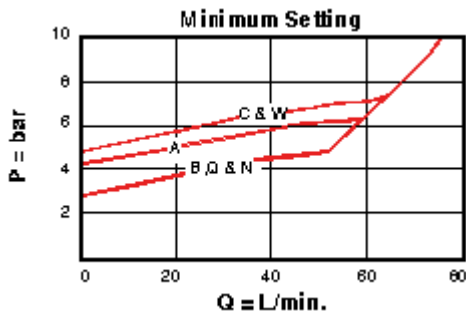

RPEC-LAN

Control	Adjustment Range	External Material/Seal Material
Preferred Options		
L Standard Screw Adjustment	A 100 - 3000 psi (7 - 210 bar), 1000 psi (70 bar) Standard Setting W 150 - 4500 psi (10,5 - 315 bar), 1000 psi (70 bar) Standard Setting	N Buna-N
Standard Options		
C* Tamper Resistant - Factory Set	B 50 - 1500 psi (3,5 - 105 bar), 1000 psi (70 bar) Standard Setting	P Stainless/Buna-N
F Hex Head Screw with Locknut	C 150 - 6000 psi (10,5 - 420 bar), 1000 psi (70 bar) Standard Setting	V Viton
K Handknob	N 60 - 800 psi (4 - 55 bar), 400 psi (30 bar) Standard Setting	W Stainless/Viton
O Handknob with Panel Mount	Q 60 - 400 psi (4 - 25 bar), 200 psi (14 bar) Standard Setting	