

# KT14-75K

14" (356 mm) 75,000 lbs-ft  
Hydraulic Power Tong



**SPECIFICATIONS | OPERATION | MAINTENANCE | PARTS**





# ORIGINAL INSTRUCTIONS

**THIS TECHNICAL DOCUMENT APPLIES TO THE FOLLOWING MODELS:**

TONG MODEL	REV	DESCRIPTION
80-1001-10	0	Tong with hydraulic motor, motor valve, lift cylinder valve, & rigid sling.
80-1001-29	0	Tong with hydraulic motor, motor valve, lift cylinder valve, & rigid sling. CLOSED CENTRE HYDRAULICS

**THIS EQUIPMENT USES A DOOR SWITCH SYSTEM DESIGNED TO INTERRUPT TONG ROTATION WHEN TONG DOOR IS OPENED**

McCoy has made an effort ensure that all illustrations are accurate, but please note that some illustrations used in this manual may not exactly visually match your equipment.

**PATENTED & PATENTS PENDING**



**This page intentionally  
left blank**



# WARNING

## READ BEFORE USING EQUIPMENT

### AUTHORIZED USE ONLY

Only authorized personnel deemed competent to operate, maintain, and repair this equipment shall do so.

Do not operate equipment without fully reviewing and complying with all safety guidelines contained within this manual.

A "LOAD-BEARING DEVICE" IS A CHAIN SLING, RIGID SLING, SPREADER BAR ASSEMBLY, FRAME, OR ANY OTHER DEVICE THAT BEARS THE PARTIAL OR TOTAL WEIGHT OF THE EQUIPMENT FOR WHICH THIS MANUAL HAS BEEN PRODUCED

THE LOAD-BEARING DEVICE SUPPLIED BY MCCOY GLOBAL IS DESIGNED TO SUPPORT THE EQUIPMENT DESCRIBED IN THIS MANUAL. MCCOY GLOBAL WILL NOT GUARANTEE THE ABILITY OF THE LOAD-BEARING DEVICE TO SUPPORT ANY OTHER PART, ASSEMBLY OR COMBINATION OF PARTS AND ASSEMBLIES. MCCOY GLOBAL WILL NOT GUARANTEE THE ABILITY OF THE LOAD-BEARING DEVICE TO LIFT OR SUPPORT THE EQUIPMENT DESCRIBED IN THIS MANUAL IF THERE ARE ANY MODIFICATIONS TO THE LOAD-BEARING DEVICE, OR ANY ADDITIONS TO THE EQUIPMENT DESCRIBED IN THIS MANUAL THAT ADD WEIGHT TO THE EQUIPMENT, UNLESS SUPPLIED BY MCCOY GLOBAL.

WHEN RE-ASSEMBLING LOAD-BEARING DEVICES (CHAIN SLINGS, RIGID SLINGS, BACKUP LEGS, ETC.) NOTE THAT THE ASSOCIATED FASTENERS MUST BE TIGHTENED TO THE CORRECT TORQUE SPECIFIED FOR THAT SIZE OF FASTENER (SEE SECTION 3 - OVERHAUL). ANY THREADED FASTENER IN A LOAD-BEARING DEVICE MUST BE SECURED WITH RED OR BLUE LOCTITE™.

ANY REPLACEMENT FASTENER (BOLTS, NUTS, CAP SCREWS, MACHINE SCREWS, ETC.) USED DURING MAINTENANCE OR OVERHAUL MUST BE GRADE 8 OR EQUIVALENT UNLESS OTHERWISE SPECIFIED.



**This page intentionally  
left blank**

Published by McCoy Global, Technical Publications Department  
14755 - 121A Avenue • Edmonton, AB, Canada, T5L 2T2

Copyright © 2013 - 2016 McCoy Global, including its wholly owned subsidiaries, ("McCoy"), all rights reserved. This document is the property of McCoy and is supplied as reference information for users of our products. This document and the contents within are considered confidential information, not to be disclosed, copied, transmitted, transcribed in any form, or stored on any type of data storage media without the express written consent of McCoy.

McCoy has made every effort to ensure the information contained in this document is accurate and current. This manual is intended to provide equipment operation and safety instructions for your equipment. However, McCoy does not warrant or guarantee that the information is either complete or accurate in every respect and the user of the manual should consult with its McCoy sales representative for any clarifications and updates.

The user of the manual shall protect, indemnify, and hold harmless McCoy and its directors, officers, employees, and agents from and against all liability for personal injury, death, or property damage resulting directly or indirectly from the use of the information contained in this manual.

Observance of all descriptions, information and instructions set out in this manual is the full responsibility of the user. This manual is intended for guidance and informational purposes and must be used in association with adequate training and on-the-job supervision to provide safe and effective equipment use.

It is the responsibility of the user to conform to all regulations and requirements issued by an authority or agency which may affect the operation, safety or equipment integrity, that may overrule the content of this documentation.

The user will acknowledge and obey any general legal or other mandatory regulation in force relating to accident prevention, safety, and equipment integrity.

<b>Summary Of Revisions</b>					
Date	Section	Page	Description Of Revision	Approved	
JULY 2013	N/A	N/A	Initial Release (model 80-1001-09)	Bin Ma	
DEC 2013	Preamble	iii	Listed model 80-1001-10, removed obsolete model 80-1001-9	R. Rahman	
	2	2.25	Updated safety door testing procedure, subsection 2.H.5		
	3	3.15-3.20	3.15		Updated assembly instructions to reflect new model (model 80-1001-10)
		3.15	3.20		Replaced lower support roller assembly drawing (model 80-1001-10)
		3.20	3.20		Replaced upper support roller assembly drawing (model 80-1001-10)
	5	5.2	5.2		Updated Critical spare parts list
		5.3	5.3		Updated Recommended One-Year spare parts list
		5.4 - 5.5	5.4 - 5.5		Updated Overhaul required parts list
		5.7	5.7		Updated part number for rotary gear (model 80-1001-10)
		5.9	5.9		Updated part numbers for support roller components (model 80-1001-10)
		5.23	5.23		Updated part number for rotary gear (model 80-1001-10)
		5.24-5.25	5.24-5.25		Replaced illustrations, 3-½" - 5-½" jaws, updated B.O.M.
	5.26-5.27	5.26-5.27	Inserted illustrations and B.O.M., 6-5/8" to 13-5/8" jaw die kits		
	5.28-5.29	5.28-5.29	Inserted illustrations and B.O.M., 14-3/8" jaw die kit		
MAR 2016	Preamble	iii	Added model 80-1001-29	D. Sonnier	
	1	1.7	Added warnings for closed-centre hydraulic configuration		
		1.8	Added updated lubricant specifications		
	2	2.12	Updated hydraulic B.O.M. to include components for closed-centre configuration, added maximum hydraulic supply warning		
2.13		Added hydraulic schematic, closed-centre configuration			

**SECTION ONE: INTRODUCTION**

Introduction & Contact Information ..... 1.3  
 Equipment Specifications ..... 1.4

**SECTION TWO: SETUP & OPERATION**

2.A INITIAL RECEIPT AND INSPECTION OF EQUIPMENT ..... 2.3  
 2.B MAJOR COMPONENT IDENTIFICATION ..... 2.3  
 2.C SLING / LOAD BEARING DEVICE SAFETY ..... 2.6  
     2.C.1 Inspection Of Slings ..... 2.7  
     2.C.2 Proper Use Of Load-Bearing Devices ..... 2.8  
     2.C.3 Storage Of Load-Bearing Devices ..... 2.8  
 2.D LIFT CYLINDER INSTALLATION AND SAFETY ..... 2.9  
     2.D.1 Installation Procedure ..... 2.9  
     2.D.2 Lift Cylinder Hydraulic Connection ..... 2.10  
     2.D.3 Lift Cylinder Safety ..... 2.10  
 2.E HYDRAULICS ..... 2.12  
     2.E.1 Hydraulic Schematics ..... 2.12  
     2.E.2 Hydraulic Component Identification ..... 2.14  
     2.E.3 Hydraulic Connections ..... 2.16  
     2.E.4 Hydraulic Circuit Description ..... 2.17  
 2.F TONG JAW AVAILABILITY & INSTALLATION ..... 2.18  
     2.F.1 Jaw Availability ..... 2.18  
     2.F.2 Tong Jaw Installation & Removal ..... 2.19  
 2.G TONG RIG-UP & LEVELING ..... 2.20  
     2.G.1 Suspension & Restraint ..... 2.20  
     2.G.2 Tong Leveling ..... 2.22  
 2.H TONG OPERATION ..... 2.23  
     2.H.1 Operator Training ..... 2.23  
     2.H.2 Operator Safety ..... 2.23  
     2.H.3 Valve Operation ..... 2.23  
     2.H.4 Shifting Gears ..... 2.24  
     2.H.5 Pre-Operational Checks ..... 2.25  
     2.H.6 General Comments ..... 2.27  
 2.I MAKING AND BREAKING CONNECTIONS ..... 2.26  
     2.I.1 Making A Connection ..... 2.26  
     2.I.2 Breaking A Connection ..... 2.31  
 2.J EXTREME COLD WEATHER OPERATION PROCEDURES ..... 2.33

**SECTION THREE: MAINTENANCE**

3.A GENERAL MAINTENANCE SAFETY PRACTICES ..... 3.3  
 3.B CLEANING ..... 3.3  
 3.C PREVENTIVE MAINTENANCE PRACTICES ..... 3.3  
 3.D HYDRAULIC SYSTEM DE-PRESSURIZATION ..... 3.4  
 3.E LUBRICATION INSTRUCTIONS ..... 3.4  
 3.F ADJUSTMENTS ..... 3.10  
     3.F.1 Brake Band Adjustment ..... 3.10  
     3.F.2 Shifter Detent Force Adjustment ..... 3.11  
 3.G RECOMMENDED PERIODIC CHECKS ..... 3.11  
     3.G.1 Door Stop Springs ..... 3.11  
     3.G.2 Backing Pin ..... 3.11  
     3.G.3 Shifting Shaft ..... 3.11  
     3.G.4 Torque Gauge Assembly ..... 3.11  
 3.H REMOVAL OF TOP PLATE FOR OVERHAUL ..... 3.12  
 3.I ASSEMBLY PROCEDURES ..... 3.14  
 3.J DAILY INSPECTION & MAINTENANCE CHECKLIST (POWER TONG) ..... 3.33  
 3.K MONTHLY MAINTENANCE CHECKLIST - POWER TONG ..... 3.35  
 3.L TUBULAR CONNECTION EQUIPMENT DE-COMMISSIONING & SHIPPING PROCEDURE ..... 3.38  
 3.M TUBULAR CONNECTION EQUIPMENT RE-COMMISSIONING PROCEDURE ..... 3.42

**SECTION FOUR: TROUBLESHOOTING**

4.A TONG WILL NOT DEVELOP SUFFICIENT TORQUE ..... 4.3  
 4.B RELIEF VALVE IS INCORRECTLY SET OR NOT FUNCTIONING ..... 4.4  
 4.C SAFETY DOOR DOES NOT OPERATE OR IS MALFUNCTIONING ..... 4.6  
 4.D TONG RUNNING TOO SLOWLY ..... 4.7  
 4.E FAILURE OF JAWS TO GRIP PIPE ..... 4.8  
 4.F FAILURE OR DIFFICULTY OF TONG TO SHIFT ..... 4.9  
 4.G GENERAL COMMENTS ..... 4.10

Continued on next page ...

**SECTION FIVE: PARTS AND ASSEMBLIES**

Critical Spare Parts List ..... 5.2

Recommended One-Year Spare Parts List ..... 5.3

Recommended Overhaul Spare Parts List ..... 5.4

Gear Train Layout ..... 5.6

Support Half-Rollers ..... 5.8

Rotary Idler ..... 5.10

Pinion Idler ..... 5.12

Pinion Assembly ..... 5.14

Clutch Assembly ..... 5.16

Lay (Drive) Assembly ..... 5.18

Manual Shifting Assembly ..... 5.20

Cage Plate Assembly ..... 5.22

Jaw Assembly, 3-1/2" to 5-1/2" ..... 5.24

Jaw Assembly, 6-5/8" to 13-5/8" ..... 5.26

Jaw Assembly, 14" ..... 5.28

Motor & Motor Mount Assembly ..... 5.30

Hydraulic Supports ..... 5.32

Brake Bands ..... 5.34

Door Latch Assembly ..... 5.36

Safety Door Components ..... 5.37

Tong Door Assembly ..... 5.38

Rigid Sling Assembly ..... 5.40

**SECTION SIX: TORQUE MEASUREMENT**

A. BASIC TORQUE MEASUREMENT ..... 6.3

B. TROUBLESHOOTING ..... 6.7

C. PERIODIC INSPECTION AND MAINTENANCE

    1. Inspection ..... 6.8

    2. Fluid Recharge ..... 6.8

    3. Reference Checking The Torque Measurement System ..... 6.8

    4. Repair And Calibration ..... 6.9

**SECTION SEVEN: OEM DOCUMENTATION**

Illustration 1.A.1: KT14-75K Tong ..... 1.3

Illustration 1.A.2: KT14-75K Dimensions..... 1.4

Illustration 1.A.3: KT14-75K Hazard Areas..... 1.5

Illustration 1.A.4: FARR® CE Nameplate..... 1.6

Illustration 2.B.1: Major Component Identification 01 ..... 2.3

Illustration 2.B.2: Major Component Identification 02..... 2.4

Illustration 2.B.3: Major Component Identification 03..... 2.5

Illustration 2.C.1: Sling Angle ..... 2.6

Illustration 2.D.1: Lift Cylinder & Spring Hanger Installation..... 2.9

Illustration 2.D.2: Lift Cylinder Hydraulic Connection ..... 2.10

Illustration 2.E.1: Hydraulic Schematic..... 2.12

Illustration 2.E.2: Hydraulic Schematic, Closed Centre..... 2.13

Illustration 2.E.3: Hydraulic Component Identification 01 ..... 2.14

Illustration 2.E.4: Hydraulic Component Identification 02..... 2.14

Illustration 2.E.5: Hydraulic Component Identification 03..... 2.15

Illustration 2.E.6: Hydraulic Component Identification 04..... 2.15

Illustration 2.E.7: Hydraulic Connections 01..... 2.16

Illustration 2.E.7: Hydraulic Connections 02..... 2.16

Illustration 2.F.1: Jaw Removal ..... 2.17

Illustration 2.F.2: Jaw Die Removal..... 2.17

Illustration 2.G.1: Tong Suspension Relative To Axial Centre..... 2.21

Illustration 2.G.2: Tong Suspension Relative To Vertical Centre ..... 2.21

Illustration 2.G.3: Tong Leveling 01..... 2.22

Illustration 2.G.4: Tong Leveling 02..... 2.22

Illustration 2.H.1: Tong Rotation Control Valve ..... 2.24

Illustration 2.H.2: Tong Lift Cylinder Control Valve..... 2.24

Illustration 2.H.3: Tong Manual Shift Control..... 2.25

Illustration 2.I.1: Master Lifting Link..... 2.27

Illustration 2.I.2: Backing Pin Set To “Make-up” Position ..... 2.28

Illustration 2.I.3: Lift Cylinder Control (Raise)..... 2.29

Illustration 2.I.4: Opening Tong Doors..... 2.29

Illustration 2.I.5: Motor Control - Make-up ..... 2.30

Illustration 2.I.6: Motor Control - Releasing Jaws..... 2.31

Illustration 2.I.7: Lift Cylinder Control - Lower..... 2.31

Illustration 2.I.8: Setting Backing Pin To “Break-Out” Position ..... 2.32

Illustration 2.I.9: Rotation Control - Break-Out..... 2.33

Illustration 2.I.10: Releasing Tong Jaws Following Break-out & Un-threading..... 2.33

Illustration 2.I.11: Lowering Tong Using Lift Cylinder Control..... 2.34

Illustration 3.E.1: Guide Ring Lubrication ..... 3.4

Illustration 3.E.2: Support Roller Lubrication ..... 3.5

Illustration 3.E.3: Rotary Idler Lubrication..... 3.5

Illustration 3.E.4: Pinion Idler Lubrication ..... 3.6

Illustration 3.E.5: Pinion Lubrication ..... 3.6

Illustration 3.E.6: Clutch Lubrication ..... 3.7

Illustration 3.E.7: Motor Mount Lubrication ..... 3.7

Illustration 3.E.8: Shifter Component Lubrication ..... 3.8

Illustration 3.E.9: Lay Gear Lubrication ..... 3.8

Illustration 3.E.10: Door Spring Cylinder (Exploded)..... 3.9

Illustration 3.F.1: Brake Band Adjustment ..... 3.10

Illustration 3.F.2: Shifter Detent Force Adjustment..... 3.11

Illustration 3.I.1: Bottom Support Roller Assembly Drawing..... 3.15

Illustration 3.I.2: Bottom Support Roller Installation..... 3.16

Illustration 3.I.3: Clutch Assembly Drawing ..... 3.16

Illustration 3.I.4: Pinion Assembly Drawing ..... 3.17

Illustration 3.I.5: Pinion Idler Assembly Drawing ..... 3.18

Illustration 3.I.6: Pinion Bearing Race Installation ..... 3.19

Illustration 3.I.7: Rotary Idler Assembly Drawing..... 3.19

Illustration 3.I.8: Top Support Roller Assembly Drawing ..... 3.20

Illustration 3.I.9: Top Plate Fastener Installation ..... 3.21

Illustration 3.I.10: Lay Gear Assembly Drawing..... 3.22

Illustration 3.I.11: Shifting Fork Assembly Drawing ..... 3.23

Illustration 3.I.12: Cage Plate Spacer Installation..... 3.24

Illustration 3.I.13: Safety Door Cam & Lower Reinforcement Installation..... 3.25

Illustration 3.I.14: Door Latch Installation ..... 3.26

Illustration 3.I.15: Door Installation ..... 3.27

Illustration 3.I.16: Safety Door Switch Installation ..... 3.28

Illustration 3.I.17: Hydraulic Support Installations..... 3.29

Continued on next page ...

Illustration 3.I.18: Hydraulic Valve Assembly Installation ..... 3.30

Illustration 3.I.19: Rigid Sling Leveling Bolt Installation ..... 3.31

Illustration 3.L.1: Shipping Instructions - Pallet..... 3.40

Illustration 3.M.2: Shipping Instructions - Wrapping Chain Sling & Strapping To Pallet..... 3.41

Illustration 4.B.1: Relief Valve Troubleshooting - Temporary Gauge Installation ..... 4.4

Illustration 5.1: Gear Train ISO View ..... 5.6

Illustration 5.2: Gear Train Top & Side View ..... 5.7

Illustration 5.3: Support Half-Rollers Exploded ..... 5.8

Illustration 5.4: Support Half-Rollers ..... 5.9

Illustration 5.5: Rotary Idler Exploded..... 5.10

Illustration 5.6: Rotary Idler Gear Assembly ..... 5.11

Illustration 5.7: Pinion Idler Exploded ..... 5.12

Illustration 5.8: Pinion Idler Gear Assembly ..... 5.13

Illustration 5.9: Pinion Gear Assembly Exploded..... 5.14

Illustration 5.10: Pinion Gear Assembly ..... 5.15

Illustration 5.11: Clutch Gear Assembly Exploded ..... 5.16

Illustration 5.12: Clutch Gear Assembly ..... 5.17

Illustration 5.13: Lay Gear Assembly Exploded..... 5.18

Illustration 5.14: Lay Gear Assembly ..... 5.19

Illustration 5.15: Shifter Assembly Exploded ..... 5.20

Illustration 5.16: Shifter Assembly ..... 5.21

Illustration 5.17: Cage Plate Assembly Exploded..... 5.22

Illustration 5.18: Cage Plate Assembly ..... 5.23

Illustration 5.19: 3-½” to 5-½” Jaw Assembly Exploded ..... 5.24

Illustration 5.20: 3-½” to 5-½” Jaw Assembly ..... 5.25

Illustration 5.21: 6-⅝” to 13-⅝” Jaw Assembly Exploded ..... 5.26

Illustration 5.22: 6-⅝” to 13-⅝” Jaw Assembly ..... 5.27

Illustration 5.23: 14” Jaw Assembly Exploded..... 5.28

Illustration 5.24: 14” Jaw Assembly ..... 5.29

Illustration 5.25: Motor & Mount Exploded..... 5.30

Illustration 5.26: Motor & Mount..... 5.31

Illustration 5.27: Hydraulic Supports Exploded..... 5.32

Illustration 5.28: Hydraulic Supports..... 5.33

Illustration 5.29: Brake Bands Exploded..... 5.34

Illustration 5.30: Brake Bands..... 5.35

Illustration 5.31: Door Latch Assembly Exploded..... 5.36

Illustration 5.32: Safety Door Components Exploded..... 5.37

Illustration 5.33: Door Assembly Exploded..... 5.38

Illustration 5.34: Door Assembly..... 5.39

Illustration 5.35: Rigid Sling Exploded..... 5.40

Illustration 5.36: Rigid Sling..... 5.41

Illustration 6.A.1: Torque Gauge ..... 6.3

Illustration 6.A.2: Tension Load Cell..... 6.3

Illustration 6.A.3: Compression Load Cell ..... 6.3

Illustration 6.A.4: Tension Load Cell Exploded..... 6.5

Illustration 6.A.6: Turn Counter Encoder Mount Exploded ..... 6.6

## KT14-75K HYDRAULIC POWER TONG

The information presented in this document will provide setup, operating, and maintenance instructions for your KT14-75K tong. Due to the wide variety of operating conditions, these instructions must be considered guidelines rather than absolute operating procedures. It is the responsibility of the user to use these guidelines together with an experienced manager to develop operating procedures that conform to all policies set forth by the operating authority (ies).

### IDENTIFICATION OF WARNINGS AND OTHER NOMENCLATURE OF IMPORTANCE USED IN THIS TECHNICAL MANUAL

McCoy Global uses three indicators to describe items of three degrees of importance.

A **HAZARD** to operators or equipment is represented by an exclamation point within a red triangle. identifies items of the highest importance. Failure to heed information identified by a **HAZARD** symbol may result in bodily injury, death, catastrophic equipment damage, or any combination of these. A **HAZARD** may also indicate the potential for dangerous environmental contamination.



**This identifies a HAZARD to operators or equipment**

A **WARNING** is represented by an exclamation point within an orange triangle, and contains information that will alert personnel to a potential safety hazard that is not life-threatening. A **WARNING** may also serve to alert the user to information critical to the correct assembly or operation of the equipment in use.



**This identifies a WARNING to users**

A **CAUTION** is represented by an exclamation point within a yellow triangle and highlights information that may aid the user during assembly or operation of your equipment. **CAUTIONS** are also used to ensure common errors are not made during assembly or operation of your equipment.



**This identifies a CAUTION to users**

Observance of the following is the full responsibility of the user:

- all descriptions, information and instructions set out in this manual
- any regulation or requirement issued by an authority or agency which may influence operation, safety or integrity of the equipment that overrules the content of this document.
- any legal or other mandatory regulation in force governing accident prevention or environmental protection.





**SECTION 1: INTRODUCTION & SPECIFICATIONS**



**This page intentionally  
left blank**

Congratulations on the purchase of your McCoy KT14-75K 14 inch tong. This unit will provide you with years of outstanding performance. Simple maintenance and care will extend its life and ensure years of excellent performance and reliability. The setup, operating, and maintenance instructions in this manual will assist you in giving your equipment the care it requires. Please carefully read the manual before installing and using your equipment. Replacement parts are readily available from McCoy Global Canada in Edmonton, Alberta. Note that many parts are transferable between McCoy tongs and backups. Should you need replacement parts, or should you experience any difficulty not covered in this manual, please contact:

**McCoy Global Canada Corp.**

14755 121A Avenue  
Edmonton, Alberta  
Canada T5L 2T2

Phone: 780.453.3277  
Fax: 780.455.2432

Email Engineering: [engFarr@mccoyglobal.com](mailto:engFarr@mccoyglobal.com)  
Email Sales: [salesFarr@mccoyglobal.com](mailto:salesFarr@mccoyglobal.com)

Website: <http://www.mccoyglobal.com/drilling-completions>



**Illustration 1.A.1: KT14-75K Tong**

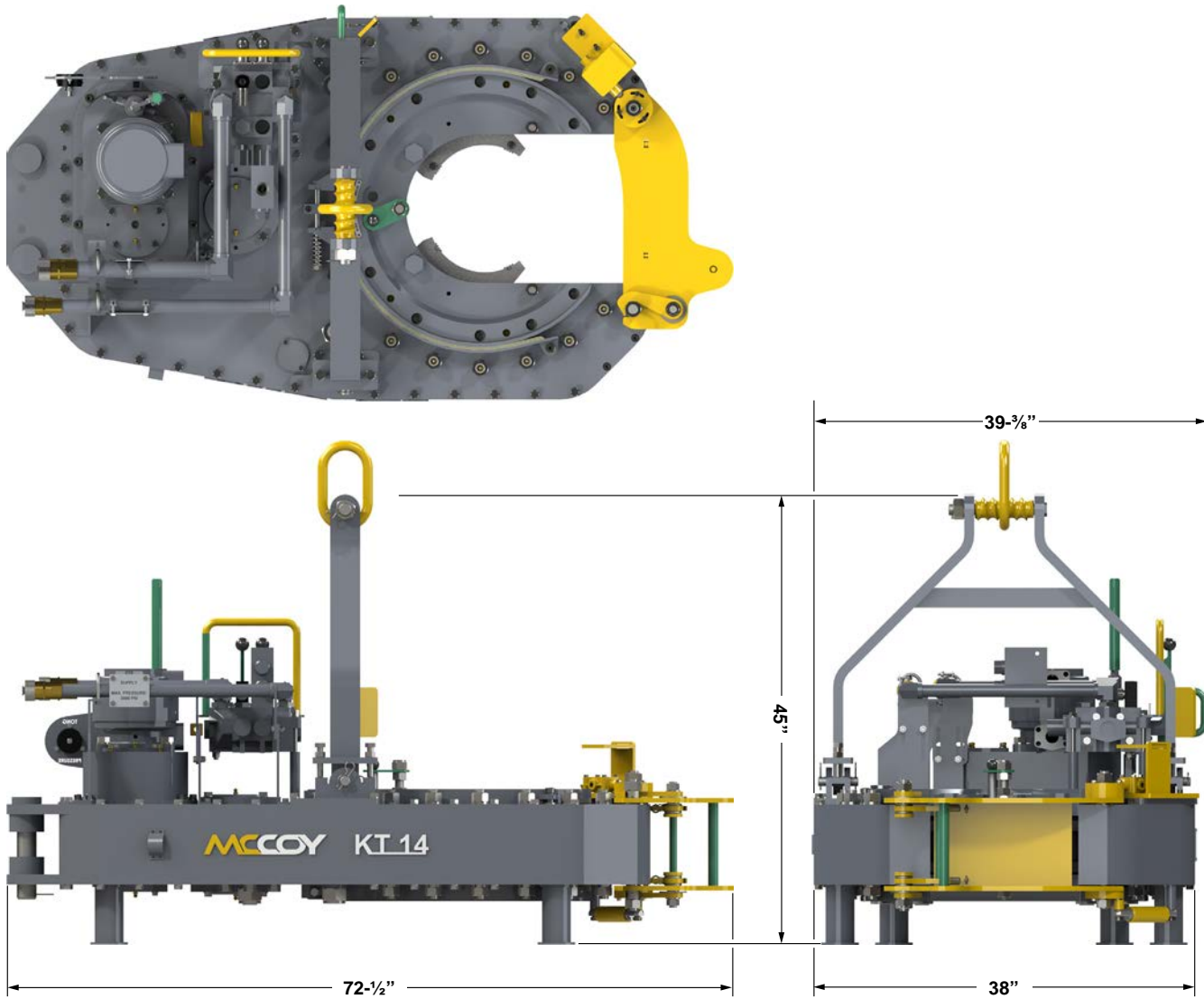


Illustration 1.A.2: KT14-75K Dimensions



ALL REPLACEMENT FASTENER (BOLTS, NUTS, CAP SCREWS, MACHINE SCREWS, ETC.) USED DURING MAINTENANCE OR OVERHAUL MUST BE GRADE 8 OR EQUIVALENT UNLESS OTHERWISE SPECIFIED.

In addition to the **HAZARD** areas of this equipment that are coated **YELLOW**, the rotating cage plate assembly poses a significant hazard when the equipment is active. Keep hands clear of the cage plate when equipment is energized. **SAFE** areas to handle while the equipment is energized are indicated by **GREEN** coating

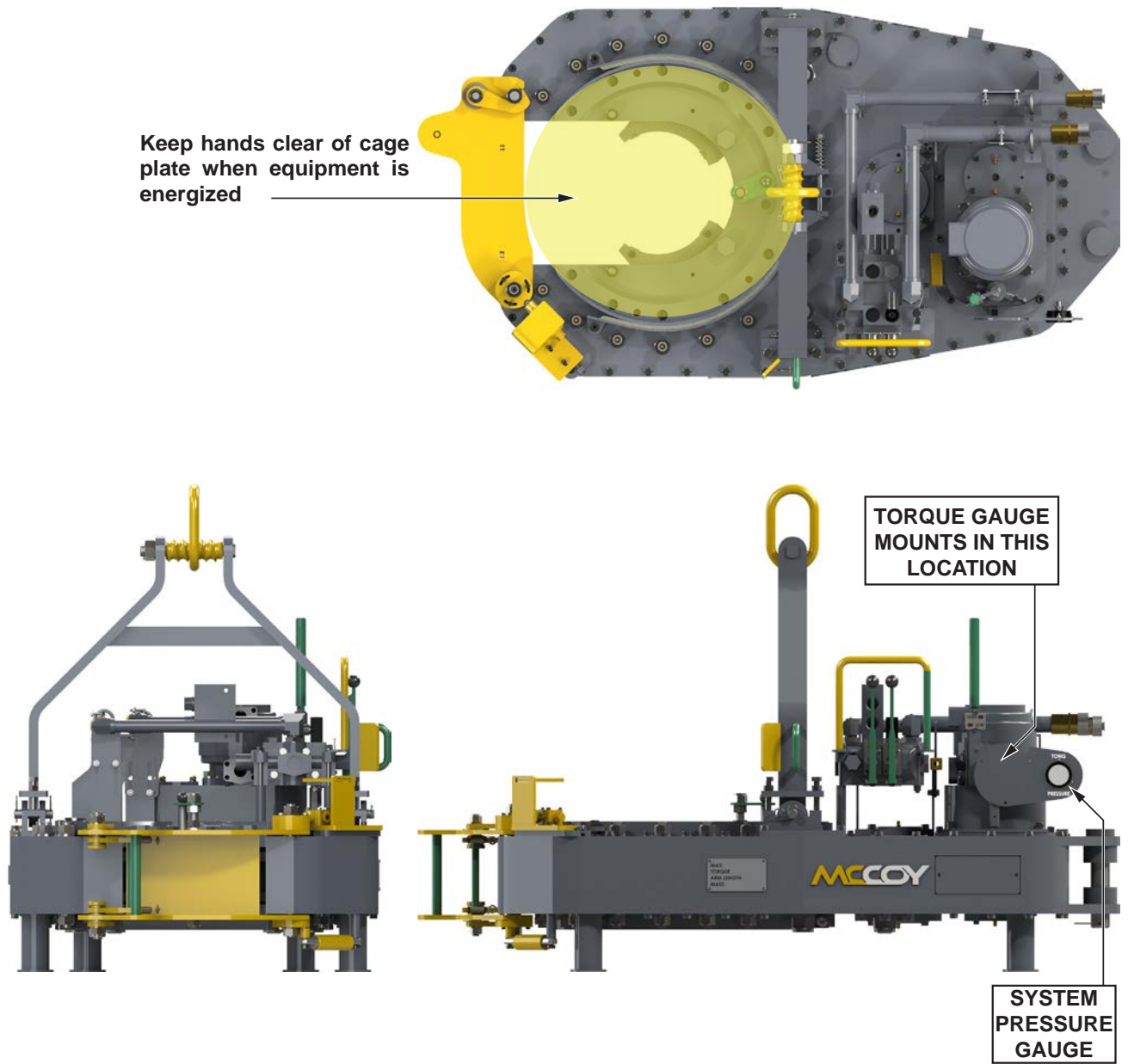
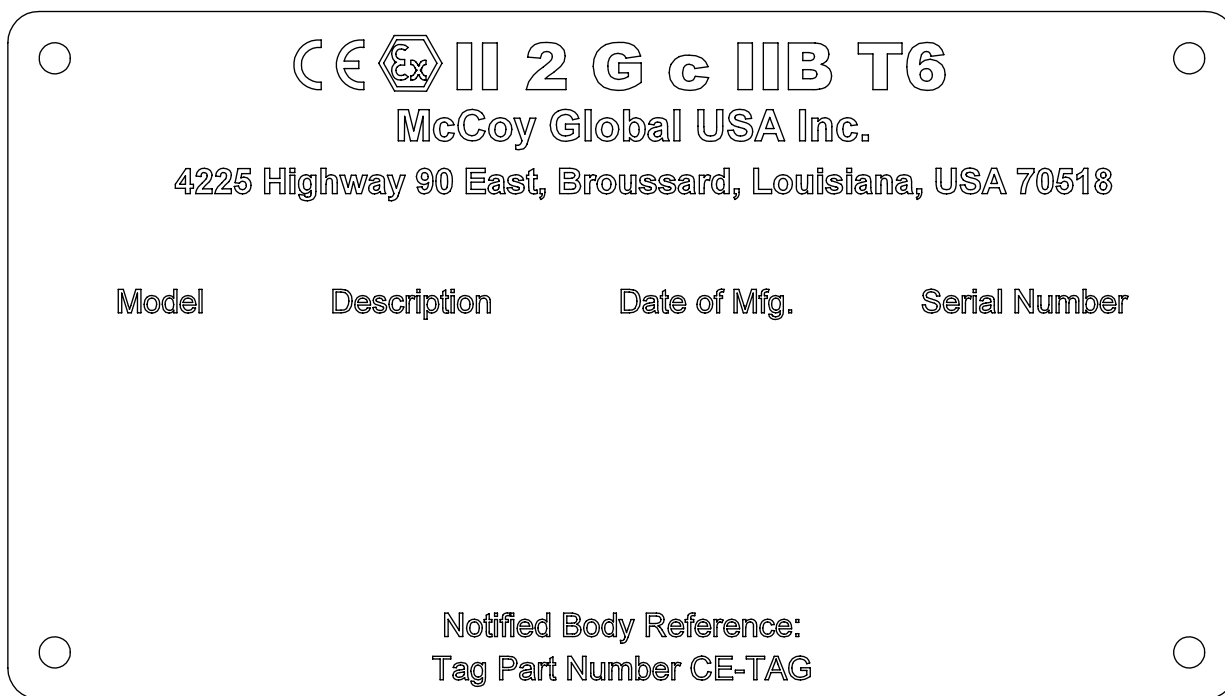
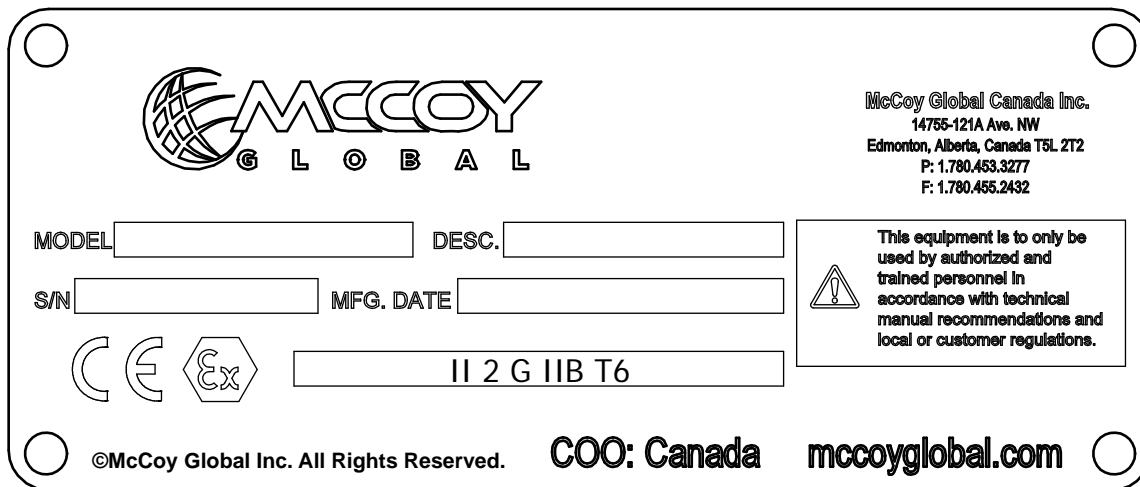


Illustration 1.A.3: KT14-75K Hazard Areas



**Illustration 1.A.4: McCoy CE Nameplates**

**CE** CE compliant. Conforms with the essential requirements of the applicable Conformité Européenne directives.

**Ex** EU Explosive Atmosphere certified

**II** Equipment Group (surface, non-mining)

**2** Equipment Category - high level of protection

**Gc** Gas Group (Acetylene & Hydrogen) - Certified for use in an acetylene / hydrogen environment

**T6** Maximum surface temperature of 85 °C.

**Torque Table**

Please note that these are ideal values. Actual achieved torque is highly dependant upon tong efficiency and final position of rotary gear when full torque load is reached. Maximum torque is only available in low gear and full motor displacement.

Pressure	High Gear		Low Gear	
	Lb-ft	Nm	Lb-ft	Nm
1000 / 6.89	4381	5940	22285	30214
1500 / 11.03	8032	10890	40856	55393
2000 / 13.79	11684	15841	59428	80574
2420 / 16.69	14751	20000	75000	101686

**MAXIMUM RATED TORQUE: 75000 LB-FT / 101686 Nm**

**REQUIRED SYSTEM PRESSURE: 2420 PSI / 16.69 MPa**

**MAXIMUM SYSTEM PRESSURE: 2500 PSI / 17.24 MPa**

**MAXIMUM SYSTEM FLOW: 60 USGPM / 227.1 LPM**

**Speed Table**

Flow (GPM/LPM)	Low Gear (RPM)	High Gear (RPM)
10 / 37.9	0.7	4
20 / 75.7	1.5	7.9
45 / 170.3	3.3	17.9
60 / 227.1	4.4	23.8

 **DANGER**

**DO NOT EXCEED MAXIMUM SPECIFIED FLOW OR PRESSURE**

<b>Maximum hydraulic requirements</b>		60 GPM (227.1 LPM)
		2500 PSI (17.237 MPa)
Maximum allowable hydraulic return line pressure		200 PSI (1.378 MPa)
<b>Maximum dimensions</b>	<b>Length (doors closed)</b>	72-½" / 1.841 m
	<b>Height</b>	45" / 1.143 m
	<b>Max Width</b>	39-¾" / 1.00 m
<b>Maximum elevator diameter</b>		Unlimited (tong comes off pipe)
<b>Torque arm length (pipe center to anchor center)</b>		45-½" / 1.156 m
<b>Gear reduction ratio, turn counter encoder to ring gear</b>		14.833 (60-0001 mount)
<b>Dead weight</b>		3150 lb / 1431 kg
<b>Maximum rigid sling load</b>		6500 lb / 2948 kg
<b>Sound level (dBa)</b>		97 dB A @ 1m / 96 dB C @ 1m
<b>Jaws available (inches)</b>		All standard sizes from 4-½" to 14-¾" (See Pg. 2.11)
<b>Recommended spring hanger</b>		85-0106HDS (Capacity = 5900 lb / 2676 kg)

 **DANGER**

**ONLY USE SPRING HANGERS SUPPLIED BY MCCOY GLOBAL.**

**RECOMMENDED LUBRICANT SPECIFICATIONS**

**Hydraulic Fluid**

McCoy Global recommends using high-quality hydraulic fluid containing rust & oxidation inhibitors and foam suppressant that meets the following requirements. Operating this equipment using hydraulic fluid that does not meet these requirements greatly accelerates equipment damage due to (but not limited to) premature component wear, premature seal failure, cavitation, and fluid starvation.

**⚠ CAUTION**

**OPERATING THIS EQUIPMENT USING HYDRAULIC FLUID THAT DOES NOT MEET THE LISTED REQUIREMENTS GREATLY ACCELERATES EQUIPMENT DAMAGE.**

Hydraulic Fluid Standards	
Characteristic	Requirement
Maximum viscosity at cold startup	<1000 cSt (<4600 SUS)
Operating viscosity range	100 to 16 cSt (170 to 80 SUS)
Minimum viscosity (intermittent periods only)	10 cSt (60 SUS)
Hydraulic fluid operating temperature range	86 - 140°F (30 - 60°C) - measured in main reservoir
Maximum fluid temperature	180°F (82°C)
Fluid cleanliness	Filtered to ISO 4406:1999 (22/18/13)

Hydraulic fluid should be chosen with due regard to expected climactic conditions and equipment load. Note that this equipment may have been tested using hydraulic fluid that does not meet operational requirements beyond those specified in the above table. Therefore, McCoy recommends purging and flushing the equipment's hydraulic system before connecting to a hydraulic supply.

**NOTICE**

**MCCOY GLOBAL RECOMMENDS PURGING AND FLUSHING THE EQUIPMENT'S HYDRAULIC SYSTEM BEFORE CONNECTING TO A HYDRAULIC SUPPLY.**

**Gear Fluid**

McCoy Global recommends using a high-quality universal gear fluid in gearbox and torque hub assemblies. If required, the gear fluid should meet VG150/VG220 or AGMA 4EP/5EP specifications. However, in more extreme operating conditions it may be necessary to fill the gearboxes on the equipment with gear fluid more suitable to the ambient operating environment. Refer to the following table to determine McCoy Global's recommendations for gear fluid selection.

Gear Fluid Standards	
Operating Condition	Requirement
-4°F to 41°F (-20°C to 5°C)	meets ISO VG100 or AGMA 3EP specifications
41°F to 104°F (5°C to 40°C)	meets VG150/VG220 or AGMA 4EP/5EP specifications
greater than 104°F (40°C)	meets VG320 or AGMA 6EP specifications

**Grease**

McCoy Global recommends use of a high-quality EP multi-purpose grease with an NLGI consistency grade of "2" and an NLGI performance grade of "GC-LB" for general lubrication of bearings and metal-to-metal contact.

McCoy Global recommends thoroughly greasing the equipment before first use as per the lubrication instructions in Section 5.





## SECTION 2: COMMISSIONING & OPERATION



**This page intentionally  
left blank**

Adequate setup and proper hydraulic connections are essential in ensuring reliable operation of your tong. For best results and long term reliability, read and obey the start-up instructions in this section.

2.A INITIAL RECEIPT AND INSPECTION OF EQUIPMENT



**YOUR EQUIPMENT HAS BEEN THOROUGHLY TESTED AND INSPECTED AT THE FACTORY. HOWEVER, MCCOY ADVISES INSPECTING YOUR EQUIPMENT FOR SHIPPING DAMAGE UPON RECEIPT, AND TESTING YOUR TONG BEFORE RELEASING TO AN OPERATIONAL ENVIRONMENT.**

Perform a visual inspection following removal of all packaging material. Immediately identify any shipping damage to the shipping company, and correct all damage before connecting equipment to a hydraulic power source.

2.B MAJOR COMPONENT IDENTIFICATION



**Illustration 2.B.1: Major Component Identification 01**

Item	Description
1	Rigid sling
2	Tong door
3	Tong door latch
4	Hydraulic valve assembly
5	Torque gauge mounting plate
6	Safety door switch
7	Tong door spring stop cylinder

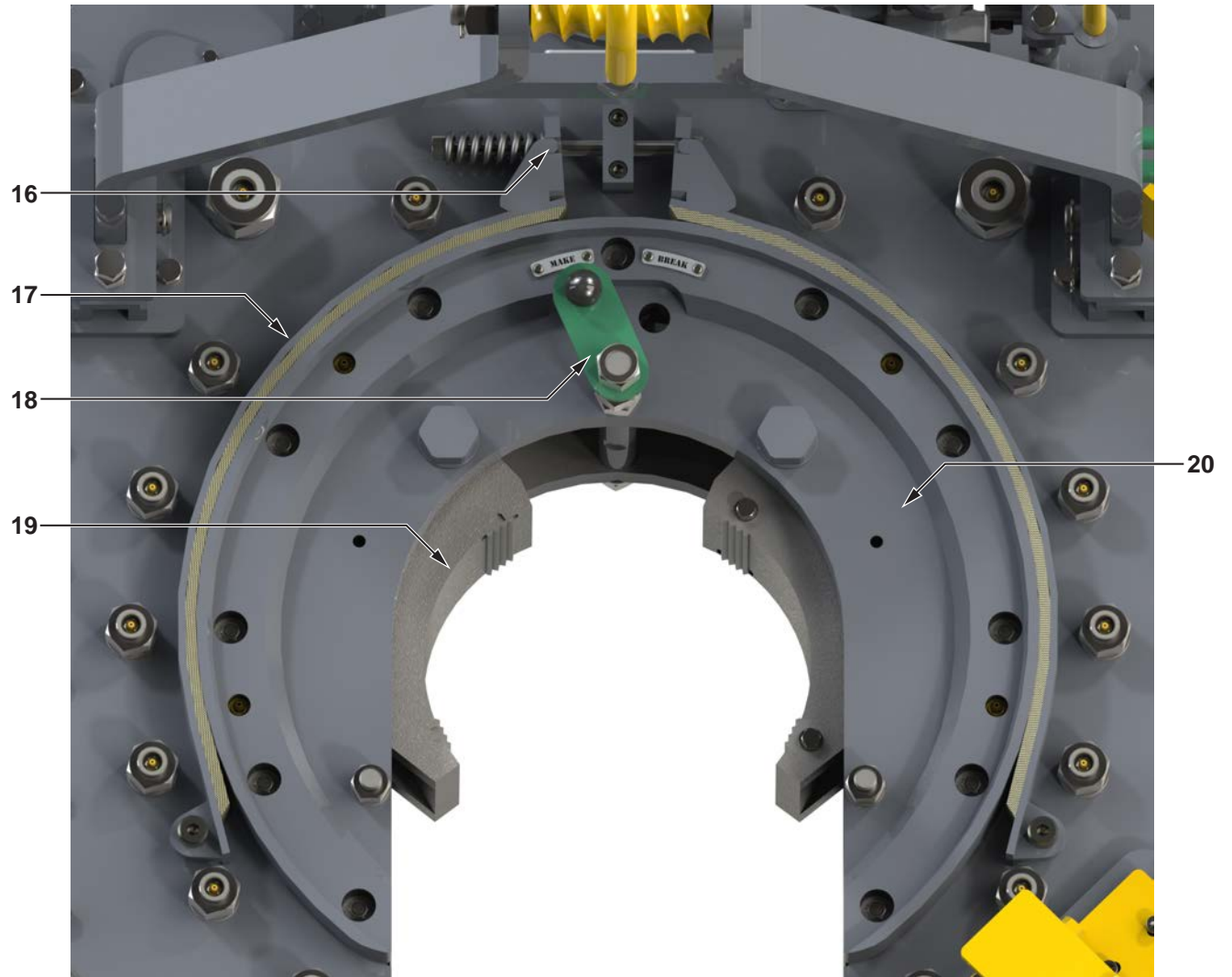
2.B MAJOR COMPONENT IDENTIFICATION (CONTINUED):



**Illustration 2.B.2: Major Component Identification 02**

Item	Description
8	Manual shift assembly
9	Rigid sling leveling adjustment
10	Shifter / clutch access panel
11	Hydraulic inlet line
12	Hydraulic discharge line
13	Hydraulic motor
14	Motor mount
15	Load cell / snub line tie-off

2.B MAJOR COMPONENT IDENTIFICATION (CONTINUED):



**Illustration 2.B.3: Major Component Identification 03**

Item	Description
16	Brake band adjustment
17	Brake band
18	Manual backing (reversing) pin assembly
19	Tong jaw with die inserts
20	Cage plate

## 2.C SLING / LOAD BEARING DEVICE SAFETY



THE SUPPLIED LOAD-BEARING DEVICE (CHAIN SLING, RIGID SLING, SPREADER BAR ASSEMBLY, FRAME, OR ANY OTHER DEVICE THAT BEARS THE PARTIAL OR TOTAL WEIGHT OF THE EQUIPMENT DESCRIBED IN THIS MANUAL) HAS BEEN SPECIFIED OR DESIGNED TO SUPPORT THE EQUIPMENT DESCRIBED IN THIS DOCUMENT. MCCOY GLOBAL WILL NOT GUARANTEE THE ABILITY OF THE LOAD-BEARING DEVICE TO SUPPORT ANY OTHER PART, ASSEMBLY OR COMBINATION OF PARTS AND ASSEMBLIES, OR ANY ADDITIONS TO THE EQUIPMENT DESCRIBED IN THIS MANUAL THAT ADD WEIGHT TO THE EQUIPMENT, UNLESS SUPPLIED BY MCCOY.

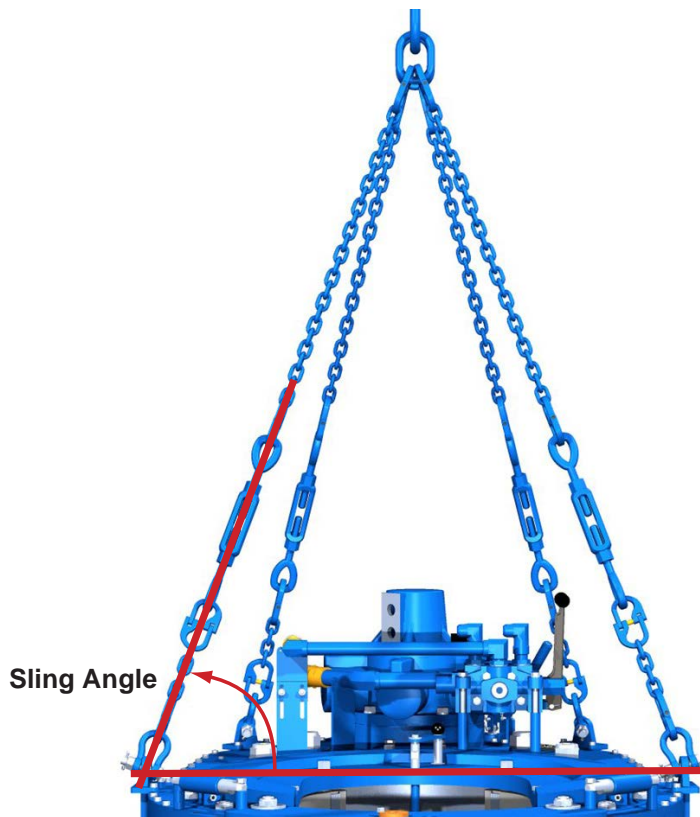
MCCOY GLOBAL DOES NOT GUARANTEE THE INTEGRITY OF MODIFIED OR DAMAGED LOAD-BEARING DEVICES, UNLESS THOSE MODIFICATIONS ARE PERFORMED BY MCCOY.

McCoy Global recommends following an industry-accepted standard such as OSHA, ASME B30.9-2006, or manufacturer's guidelines when performing any rigging and overhead lifting. Use by untrained persons is hazardous. Improper use will result in serious injury or death. Do not exceed rated capacity. Slings will fail if damaged, abused, misused, overused, or improperly maintained.

- Only grade 80 or grade 100 alloy chain should be used for overhead lifting applications.
- Working Load Limit (WLL) is the maximum allowable load in pounds which may be applied to the load-bearing device, when the device is new or in "as new" condition, and when the load is uniformly and directly applied. The WLL must never be exceeded.
- Working Load Limit (WLL) is the maximum working load for a specific minimum sling angle, measured from the horizontal plane. The Working Load Limit is identified on the sling.
- The Working Load Limit or Design factor may be affected by wear, misuse, overloading, corrosion, deformation, intentional alterations, sharp corner cutting action and other use conditions.
- Shock loading and extraordinary conditions must be taken into account when selecting alloy chain slings.
- See OSHA Regulation for Slings 1910.184, ANSI/ASME B30.9-"SLINGS", ANSI/ASME B30.10-"HOOKS" and ANSI/AMSE B30.26 "RIGGING HARDWARE" for additional information.



THE MINIMUM SLING ANGLE (THE ANGLE OF THE LEG OF THE SLING MEASURED FROM THE HORIZONTAL) MUST NEVER FALL LOWER THAN THE ANGLE SPECIFIED FOR THE SLING IN USE



**Illustration 2.C.1: Sling Angle**

**2.C.1 Inspection Of Slings**

McCoy strongly recommends the following practices:

A complete inspection of new load-bearing devices and attachments shall be performed by a qualified, designated person prior to initial use. Each link and component shall be examined individually, taking care to expose and examine all surfaces including the inner link surface. The sling shall be examined for conditions such as those listed in the removal criteria below. In addition, daily inspection of slings, fastenings and attachments shall be performed by a designated person. If damage or defects are found at either inspection, the damaged or defective component shall be quarantined from service until it can be properly repaired or replaced.

Removal Criteria:

A load-bearing device shall be removed from service if conditions such as the following are present:

- Missing or illegible sling identification.
- Cracks or breaks
- Evidence of tampering is seen - sling tag has been modified or obscured, or tamper-proof nuts are missing.
- Signs of impact on load-bearing components, including spreader bars, lifting lugs, rigid slings & rigid sling weldments, and legs & leg mounts.
- Broken or damaged welds.
- Excessive wear, nicks, or gouges. Refer to the chart below to ensure minimum thickness on chain links supplied is not be below the values listed:

<b>Minimum Allowable Chain Link Thickness at Any Point</b>			
<b>Nominal Chain Size</b>		<b>Minimum Thickness</b>	
<b>Inches</b>	<b>MM</b>	<b>Inches</b>	<b>MM</b>
7/32	5.5	0.189	4.80
9/32	7	0.239	6.07
5/16	8	0.273	6.93
3/8	10	0.342	8.69
1/2	13	0.443	11.26
5/8	16	0.546	13.87
3/4	20	0.687	17.45
7/8	22	0.750	19.05
1	26	0.887	22.53
1-1/4	32	1.091	27.71
<b>Refer To ASME B30.9</b>			

- Stretched, bent, twisted, or deformed chain links or components.
- Evidence of heat damage.
- Excessive pitting or corrosion.
- Lack of ability of chain or components to hinge (articulate) freely.
- Weld splatter.
- For hooks, removal criteria as stated in ASME B30.10
- Other conditions, including visible damage, that cause doubt as to the continued use of the sling.

Inspect all lugs and fixing points for signs of elongation and/or bending, or for material build-up around the hole. Repair or replace components that appear distorted. Ensure all hardware is tight and in good condition. Replace missing hardware if necessary. All hardware must be free of rust and corrosion.

Additional inspections shall be performed during sling use where service conditions warrant. Periodic inspection intervals shall not exceed one year. The frequency of periodic inspections should be based on:

- Frequency of use of the load-bearing device.
- Severity of service conditions
- Nature of lifts being made
- Experience gained on the service life of load-bearing devices used in similar circumstances.

Guidelines for the interval are:

- Normal Service - yearly
- Severe Service - monthly to quarterly
- Special Service - as recommended by a qualified person



**2.C.1 Inspection Of Slings (Continued):**

Units designed and manufactured in accordance with EN 12079 and DNV 2.7-1 should be tested and examined in accordance with the following schedule of examination and test. The user of the load-bearing device shall place a permanent placard or plate upon which the type and date of the last test shall be recorded. To avoid confusion, the plate shall not carry the date of the next test or examination, only the most recent.

Test / Examination				
TIME / INTERVAL	LIFTING TESTS <sup>1</sup>	NON-DESTRUCTIVE EXAMINATION (NDE) OF LIFTING POINTS	THOROUGH VISUAL EXAMINATION	SUFFIX TO BE MARKED ON PLATE ATTACHED TO UNIT
Initial Certification By McCoy Global	YES	YES	YES	T
Interval Not Exceeding 12 Months	At the discretion of inspection body	At the discretion of inspection body	YES	T or VN <sup>3</sup>
Interval Not Exceeding 60 Months	At the discretion of inspection body	YES	YES	T or VN
Following Substantial Repair or Alteration <sup>4</sup>	YES	YES	YES	T

1. Lifting test as per S 7.3 BS EN 12079 or DNV 2.7-1 May 1995  
 2. T = Proof Test, non-destructive examination; VN = non destructive examination and visual examination; V = visual examination.  
 3. Dependant upon whether non-destructive examination has been carried out.  
 4. For the purposes of this standard, a substantial repair or modification is defined as any repair and/or modification that has been carried out which may, in the opinion of the inspection body, affect the load-bearing elements of the container or lifting device, or elements that contribute directly to its structural integrity.



**IF MECHANICAL DAMAGE IS SEEN OR SUSPECTED ON A LOAD-BEARING DEVICE, OR IF THE LOAD-BEARING DEVICE HAS BEEN OVERLOADED, IT MUST BE REMOVED FROM SERVICE AND QUARANTINED UNTIL RECERTIFIED**

Written records of the most recent periodic inspection shall be maintained, and shall include the condition of the sling.

**2.C.2 Proper Use Of Load-Bearing Devices**

Whenever any load-bearing device is used, the following practices shall be observed.

- Load-bearing devices that are damaged or defective shall not be used.
- Slings shall not be shortened with knots or bolts or other makeshift devices.
- Sling legs shall not be kinked.
- Load-bearing devices shall not be loaded in excess of their rated capacities.
- Slings shall be securely attached to their load.
- Load-bearing devices shall be protected from snagging, and shall not be further obstructed by any object.
- Suspended loads shall be kept clear of all obstruction.
- All employees shall be kept clear of loads about to be lifted and of suspended loads.
- Hands or fingers shall not be placed between the sling and its load while the sling is being tightened around the load.
- Shock loading is prohibited.
- Do not stand directly under a load during lifting.

**2.C.3 Storage Of Load-Bearing Devices**

Proper storage of out-of-service load bearing devices is important to ensure full integrity of the device once it is returned to service. McCoy recommends observing the following practices.

- Wipe off all excess grease. Use a solvent-based cleaner on rags to wipe all external surfaces to remove residual grease or hydraulic fluid. Once the outside surfaces have been de-greased, wipe all external surfaces with clean water to remove residual solvent.
- McCoy recommends that an anti-corrosive agent such as Tectyl<sup>®</sup> 506 be applied to all external surfaces. Refer to manufacturer data sheets for proper application and safety information. Allow the anti-corrosive coating ample time to dry - refer to manufacturer data sheets for drying times at room temperature.
- Store in a clean, dry location. When returning to service, note that a full inspection of the device must be performed.



**2.D LIFT CYLINDER INSTALLATION AND SAFETY**

The lift cylinder is not orientation-specific; that is, the lift cylinder will function the same way independent of which end is connected to the crane and which end is connected to the main lifting lug of the tong (or the spring hanger, if used). However, McCoy recommends orienting the lift cylinder with the hydraulic hose connection at the bottom of the cylinder to ensure the hose is not stressed when cylinder is at full extension.



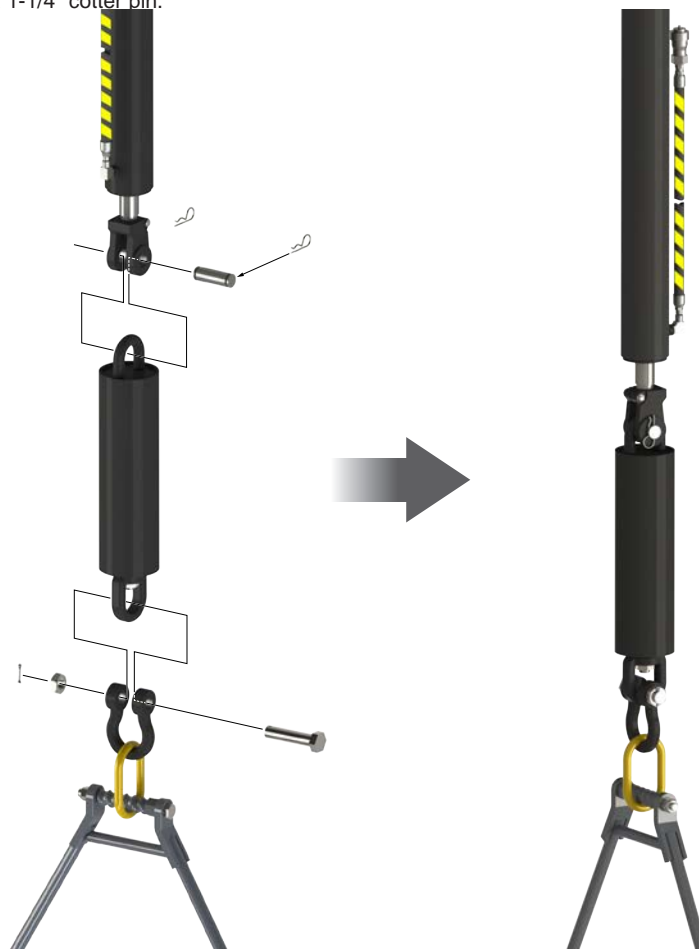
**TEST LIFT CYLINDER BEFORE INSTALLATION. REFER TO THE LIFT CYLINDER TECHNICAL MANUAL FOR DETAILED TESTING AND OPERATING PROCEDURES, AND DETAILED SAFETY GUIDELINES.**



**IF USING A SPRING HANGER ITS WEIGHT MUST BE ACCOUNTED FOR WHEN CALCULATING TOTAL SUSPENDED WEIGHT.**

**2.D.1 Installation Procedure**

- i. Use a crane to hoist the lift cylinder by the shackle, ensuring the hydraulic hose connection is at the bottom of the cylinder when it is hoisted.
- ii. Remove the two R-clips securing the clevis pin, and remove the clevis pin.
- iii. Orient the spring hanger so the piston will extend down during thread make-up, preventing water and debris from gathering around the seal.
- iv. Place the welded U-connection inside the clevis. Replace the clevis pin, and secure the clevis pin with the two R-clips.
- v. Hoist the lift cylinder and spring hanger.
- vi. Place a 1" shackle around the master lifting link on the tong sling. Secure the shackle to the extending end of the spring hanger using the 1-1/8" UNC x 4-3/4" modified hex bolt and 1-1/8" UNC hex jam nut. Secure the jam nut to the bolt using a 3/16" x 1-1/4" cotter pin.



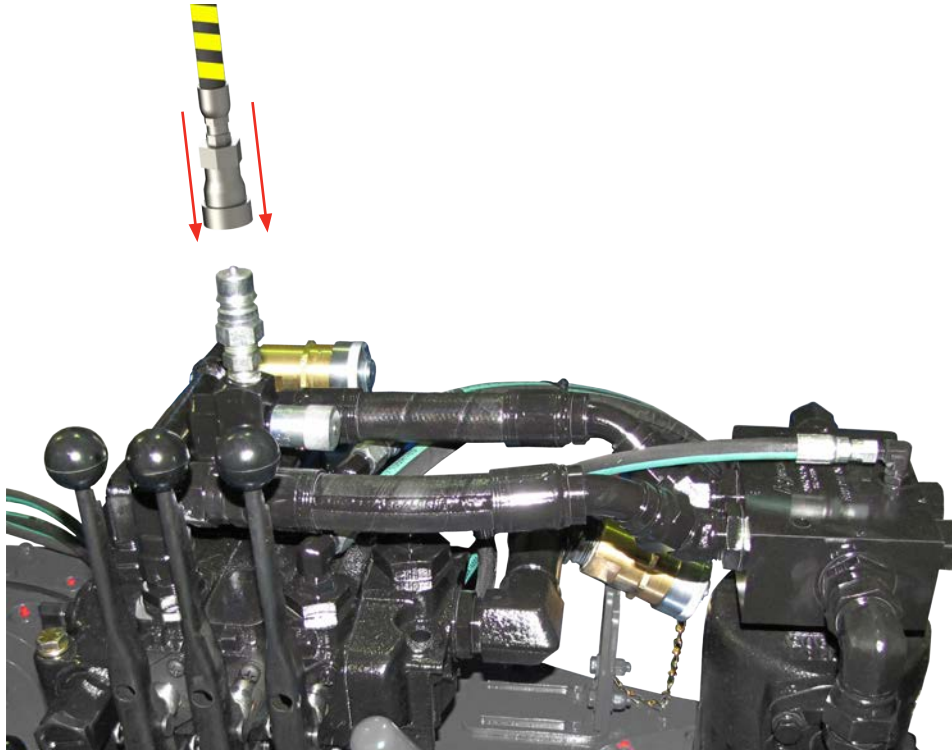
**Illustration 2.D.1: Lift Cylinder & Spring Hanger Installation**

**2.D.2 Lift Cylinder Hydraulic Connection**

Inspect the hydraulic hose before connection, ensuring the line is free of ruptures, cracks, cuts, or other damage. Inspect the female quick-connect fitting to ensure it is free from damage. Connect the female quick-connect on the lift cylinder hydraulic hose to the male quick-connect fitting attached to the needle valve on the tong valve bank. Once the fitting has snapped into place give the hydraulic line a light tug upwards to ensure the fitting is securely seated.

If not already done, connect the main hydraulic supply to the power tong (see section 2.F for proper hydraulic connection procedure). Energize the hydraulic supply to the power tong.

Lift the power tong approximately three inches off the work surface, and suspend the tong for approximately thirty seconds. Following the suspension alternately lift and lower the tong slightly to confirm that lift and lower functions each operate correctly.



**Illustration 2.D.2: Lift Cylinder Hydraulic Connection**

**2.D.3 Lift Cylinder Safety**

**A CLEARLY IDENTIFIED REMOTE POWER PACK EMERGENCY STOP MUST BE INSTALLED IN THE IMMEDIATE VICINITY OF THE TONG OPERATOR.**

McCoy Global recommends following an industry-accepted standard such as OSHA, ASME B30.9-2006, or manufacturer's guidelines when performing any rigging and overhead lifting. Use by untrained persons is hazardous. Improper use will result in serious injury or death. Do not exceed rated capacity.

Working Load Limit (WLL) is the maximum allowable load in pounds which may be applied to the load-bearing device, when the device is new or in "as new" condition, and when the load is uniformly and directly applied. The WLL must never be exceeded.

The Working Load Limit or Design factor may be affected by wear, misuse, overloading, corrosion, deformation, intentional alterations, sharp corner cutting action and other use conditions.

See OSHA Regulation for Slings 1910.184, ANSI/ASME B30.9-"SLINGS", ANSI/ASME B30.10-"HOOKS" and ANSI/AMSE B30.26 "RIGGING HARDWARE" for additional information.

**2.D.3 Lift Cylinder Safety (continued):**

The flexible line providing hydraulic power to the lift cylinder has been equipped with abrasion-resistant, high visibility protective wrap. The high visibility wrap allows operators to easily see monitor the position of the hydraulic line at all times, and can easily see if the line appears to become entangled or snagged.



**IMMEDIATELY CEASE LIFT CYLINDER OPERATION IN THE EVENT OF ENTANGLEMENT OF THE HYDRAULIC LINE WITH FIXED RIG COMPONENTS OR TONG SUPERSTRUCTURE.**

The protective wrap also prevents wear of the hydraulic line through abrasion. Do not remove the protective wrap from the lift cylinder line, and replace protective wrap if it is missing, torn, or split. Regardless of use or condition, the hydraulic line supplying the lift cylinder must be replaced every two years.



**REPLACE LIFT CYLINDER HYDRAULIC LINE EVERY TWO YEARS**

The control valve section on the power tong is equipped with an internal check valve, preventing sudden drop of the tong in the event of hydraulic power failure. A speed-limiting orifice is installed in the breather port of the lift cylinder. The orifice prevents sudden drop of the lift cylinder in the event of a ruptured hydraulic line, limiting the speed at which the cylinder extends and the tong drops to a safe rate. Do not remove the speed-limiting orifice, and only replace with an identical orifice supplied by McCoy.



**DO NOT REMOVE THE SPEED-LIMITING ORIFICE FROM THE LIFT CYLINDER BREATHER PORT**

The working load limit (WLL) is clearly stenciled on to the side of the lift cylinder. Do not use lift cylinder if the WLL stencil has been rubbed off or intentionally removed. Locate the test certificate that accompanied the cylinder to the job site or, if necessary, obtain a copy of the test certificate from the location at which the original certificate has been stored. The lift cylinder must be clearly re-marked with the WLL before it is released to an operating environment.



**DO NOT USE A LIFT CYLINDER WITH A MISSING OR DEFACED WLL STENCIL.**

2.E HYDRAULICS

2.E.1 Hydraulic Schematic

Disregard optional features on the following schematics that do not apply to your particular model.

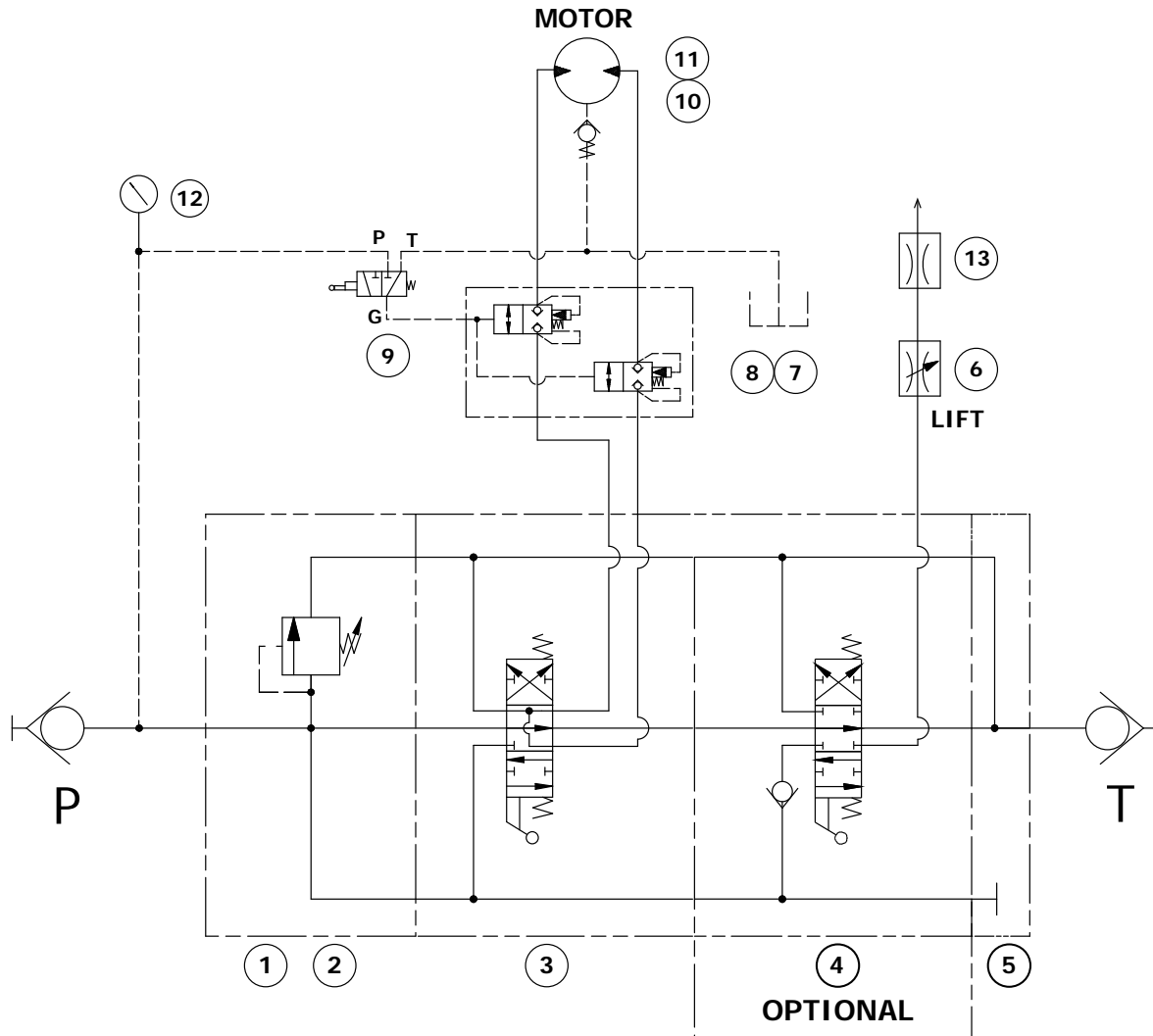


Illustration 2.E.1: Hydraulic Schematic

**! DANGER**

**DO NOT EXCEED MAXIMUM SPECIFIED FLOW OR PRESSURE. REFER TO THE SPECIFICATIONS IN SECTION 2**

Item	Description	Part Number	Item	Description	Part Number
1	Hydraulic inlet valve	10-9016	7	Pilot-to-operate cartridge valve	08-1625
2	Relief valve	10-0010R	8	Door switch valve block	101-0727
3	Motor section, SAE ports	10-9014	9	Door switch	02-E0190
4	Lift section, 1" ORB port (Optional)	10-9019	10	Check valve	02-9228
5	Outlet section, SAE ports	10-0086	11	Hydraulic motor	87-0130
5A	Outlet section, SAE ports, CLOSED CENTRE		12	0 - 3000 PSI pressure gauge	02-0245
6	Flow control valve	08-9062	13	Lift cylinder orifice	CE-ORIFICE



2.E.2 Hydraulic Component Identification:

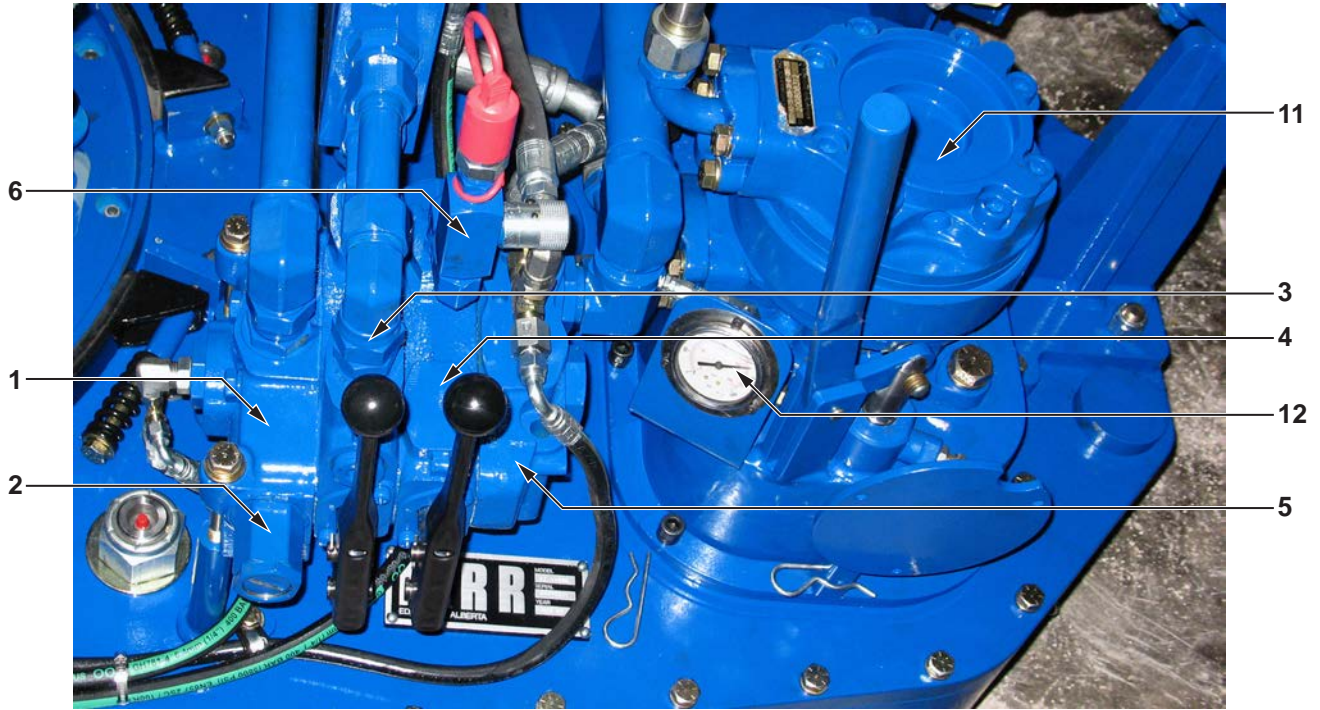


Illustration 2.E.3: Hydraulic Component Identification 01

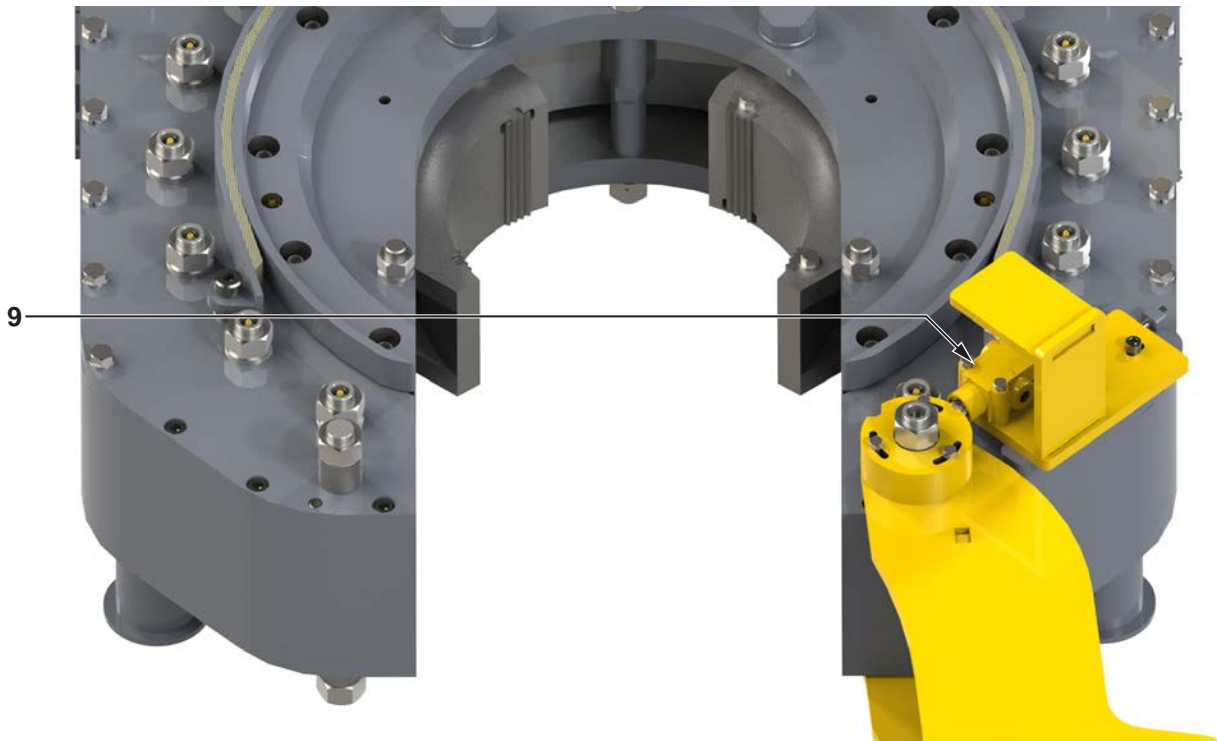
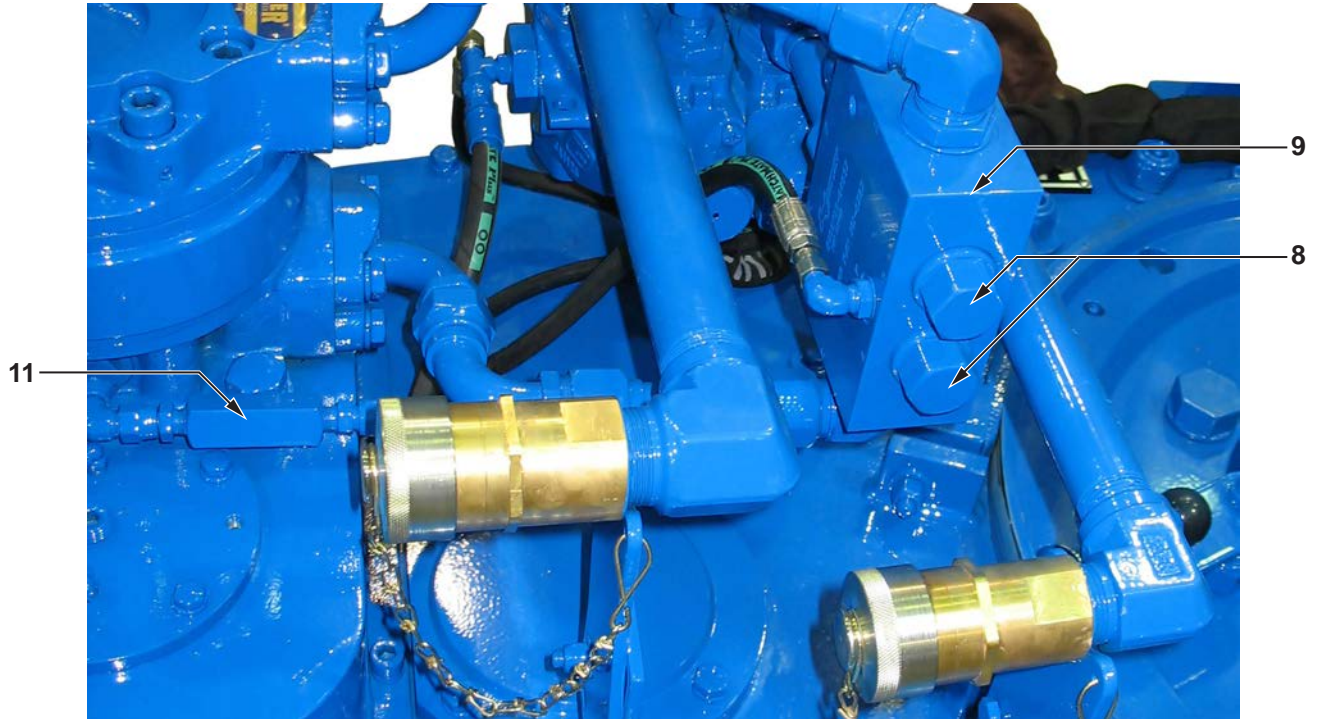


Illustration 2.E.4: Hydraulic Component Identification 02



2.E.2 Hydraulic Component Identification (Continued):

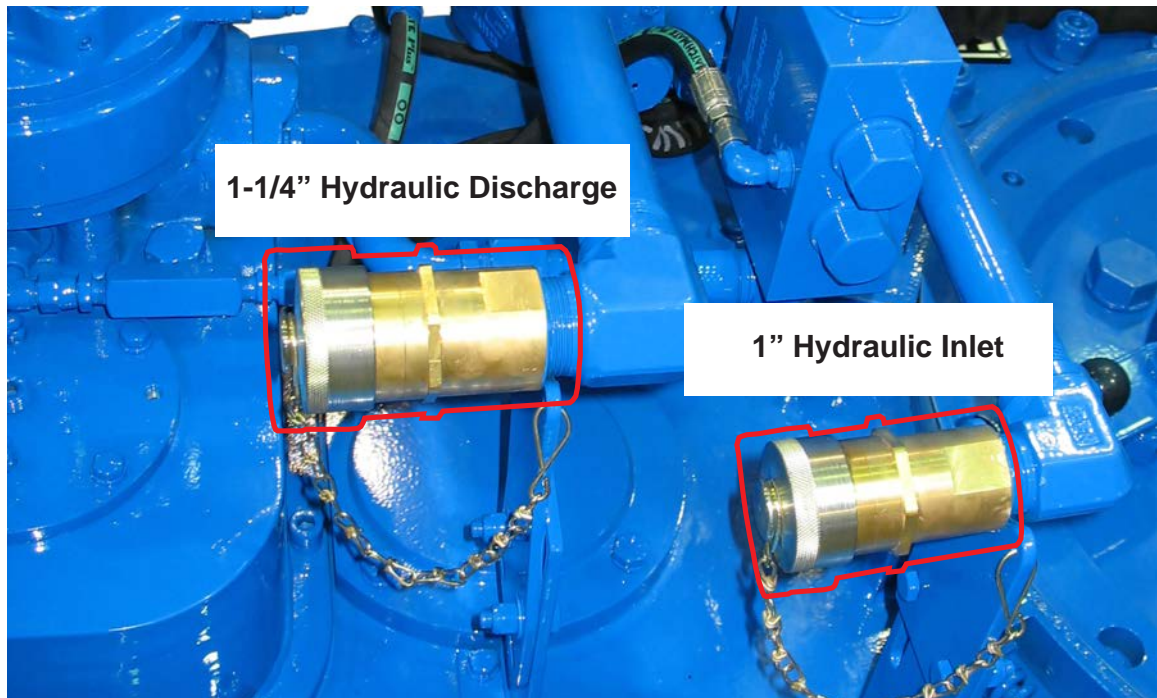


**Illustration 2.E.5: Hydraulic Component Identification 03**

2.E.3 Hydraulic Connections

A pair of hydraulic lines - a 1-1/4" supply line and a 1" return line - connect the tong to the power unit (see illustration below). Ancillary devices (hydraulic motors, hydraulic cylinders, etc.) are connected through the valve block.

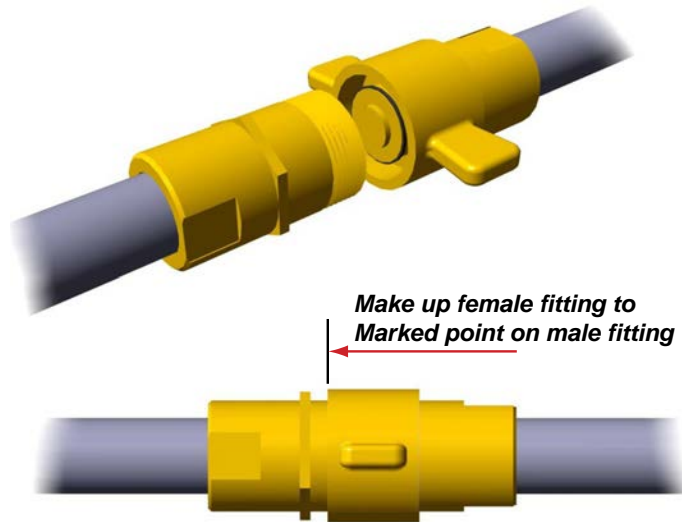
Perform any hydraulic connection when the power unit is not running, or when the hydraulic pump is disengaged. The possibility of error in inter-changing the high pressure supply hose and the low pressure return hose has been eliminated, because the supply side coupling is smaller than the return side.



**Illustration 2.E.6: Hydraulic Connections 01**

**2.E.3 Hydraulic Connections (Continued):**

These hose couplings are self-sealing, and care should be taken to ensure complete engagement to prevent partial closure of the check valve in the coupling. Ensure that the nut (female) side is completely made up onto the male connector - there is a line on the male fitting that indicates complete make-up. Snug the female fitting right up to the line.



**Illustration 2.E.7: Hydraulic Connections 02**



**A CLEARLY IDENTIFIED REMOTE POWER PACK EMERGENCY STOP MUST BE INSTALLED IN THE IMMEDIATE VICINITY OF THE TONG OPERATOR.**

Inspect these connections upon activation of the power unit. Leaking components must be repaired before releasing the tong to the operational environment. Deactivate the power unit and de-pressurize the hydraulic system according to the procedure in Section 3.D. Disconnect the main hydraulic connections and inspect all four connectors (two male, two female) for damage or debris. If the connectors cannot be cleaned or easily repaired, McCoy recommends replacement of the leaking connector. Note that damage to one of the connectors may have caused damage to its mate.

Turn off power unit and depressurize hydraulic system before disconnecting the main hydraulic lines under normal working conditions. See Section 3.D for hydraulic system depressurization. McCoy recommends placing protective caps over the exposed connectors to protect them from water and impact damage.



**ALWAYS TURN OFF HYDRAULIC POWER AND DEPRESSURIZE HYDRAULIC SYSTEM BEFORE DISCONNECTING MAIN HYDRAULIC LINES.**

**2.E.4 Hydraulic Circuit Description**

Refer to the sections 2.E.1, hydraulic schematic(s) and 2.E.2, hydraulic component identification, for assistance identifying components described in this circuit description.

The main hydraulic power source supplies hydraulic fluid to the hydraulic valve block inlet section through a 1" threaded positive-shutoff connection. Hydraulic fluid circulates through the inlet section, the motor control section, the optional lift section, and the outlet section at maximum tong pressure before returning to the hydraulic fluid reservoir (the "tank") through a 1-1/4" threaded positive-shutoff connection. The system relief valve is factory adjusted to limit the maximum operating pressure of the tong to that which will allow maximum torque. Maximum operating pressure and maximum torque are listed in the specifications on page 1.5.

The motor control valve section features proportional control. Actuating the valve handle on the motor control section directs hydraulic fluid to the hydraulic motor through the safety door cartridge integrated into the inlet valve causing rotation of the motor. During normal operation pilot pressure from the safety door switch directs pilot pressure to actuate the safety door cartridge, allowing full hydraulic power to the motor. The configuration of the plumbing between the motor valve section and the motor determines the direction of rotation for a given valve action. McCoy Global normally configures the plumbing on this tong so that pushing the valve control handle towards the centre of the tong supplies hydraulic pressure to the "clockwise rotation" side of the motor, which is the desired direction of rotation for making up a tubular connection.

**Continued on next page...**



**2.E.4 Hydraulic Circuit Description**

Conversely, pulling the valve control handle towards the operator supplies hydraulic pressure to the “counter-clockwise rotation” side of the motor, which is the desired direction of rotation for breaking out a tubular connection. Releasing the valve handle enables the valve to go to a neutral position, directing all hydraulic fluid to the outlet section and “back to tank”. The proportional nature of the valve allows the motor speed to be controlled depending on the position of the valve, regardless whether the motor is being run in the make-up or break-out direction, or whether the motor is in the high speed or low speed state.

A check valve installed on the case drain line between the motor and the main tank return line, or the internal case drain, protects the motor from excess pressure in the event of blockage in the tank line.

Actuating the valve handle on the lift cylinder section directs hydraulic fluid to the lift cylinder, which is connected to the master link on the rigid sling and provides raising and lowering functions to the tong and backup assembly. Although the lift cylinder is designed to be a double-acting cylinder, normally only the “lift” side is connected to hydraulic pressure from the lift cylinder valve. Actuating the lift cylinder valve in the “lower” direction provides a path to tank for the hydraulic fluid in the lift cylinder and allows the load suspended on the lift cylinder to force the hydraulic fluid from the cylinder, through the valve. In other words the “lowering” action is a function of gravity, not active hydraulics. The position of the lift cylinder valve controls the rate at which the cylinder lowers the tong and backup assembly. An adjustable needle valve on the pressure line to the lift cylinder allows an operator to set the rate at which hydraulic fluid is supplied to the lift cylinder, thus controlling the maximum rate at which the cylinder raises and lowers. A breather port installed in the opposite side of the lift cylinder allows the cylinder to breathe as the piston in the lift cylinder moves. The configuration of the plumbing between the lift cylinder valve section and the cylinder determines the action of the lift cylinder for a given valve action. McCoy Global normally configures the plumbing on this tong so that pushing the valve control handle towards the centre of the tong supplies hydraulic pressure to the lift cylinder, which causes the cylinder to retract, thus providing a lifting action. Pulling the valve control handle towards the operator allows a path back to tank, which allows gravity to extend the cylinder and lowers the equipment. Allowing the handle to go to neutral stops all hydraulic fluid movement to or from the lift cylinder.

Hydraulic fluid at maximum tong pressure flows from the valve inlet section to the safety door switch. During normal operation the plunger on the safety door switch is depressed when the tong door is closed, directing a hydraulic pilot signal to the safety door element.

This pilot pressure actuates the safety door cartridge, allowing full system pressure to the motor when the motor control valve is manipulated. Releasing the plunger on the safety door switch by opening the tong door diverts all hydraulic fluid from the safety door switch to the tank line, interrupting pilot pressure to the safety door cartridge. The safety door cartridge immediately inhibits system pressure to the motor. Full hydraulic power to the motor cannot be restored until the plunger on the safety door switch is depressed by fully closing the tong door.

Units equipped with a WinCATT dump valve are monitored by the WinCATT torque management system, which is connected to the dump valve by an electrical cable. Achieving user-specified torque during connection operations causes the WinCATT system to generate an electrical signal, energizing the solenoid (item 15 on the hydraulic schematic and on page 2.16) in the dump valve body (item 14 on the hydraulic schematic and on page 2.16) and opening the dump valve to “dump” system pressure directly to tank.

**2.F TONG JAW AVAILABILITY & INSTALLATION****2.F.1 Jaw Availability**

The following table lists all jaw die kits that are available as standard stocked sizes for this model of tong. McCoy Global offers a good selection of standard jaw sizes. However, please note that we can custom-engineer and manufacture any size of jaw within the range of the tong. Jaw systems are available to allow use of die inserts intended for specialized applications. Call our sales office for information on jaw and die systems designed for higher or lower grip, or non-marking applications.

The table lists standard contoured, flat and wraparound die inserts that are available as spare parts. However, a wide variety of diamond-tooth, GRITFACE®, aluminium, and wrap-around fine-tooth dies are available for specialized applications. Please refer to our website for complete information:

<http://www.mccoysglobal.com/dies-inserts>

2.F.1 Jaw Availability (Continued):

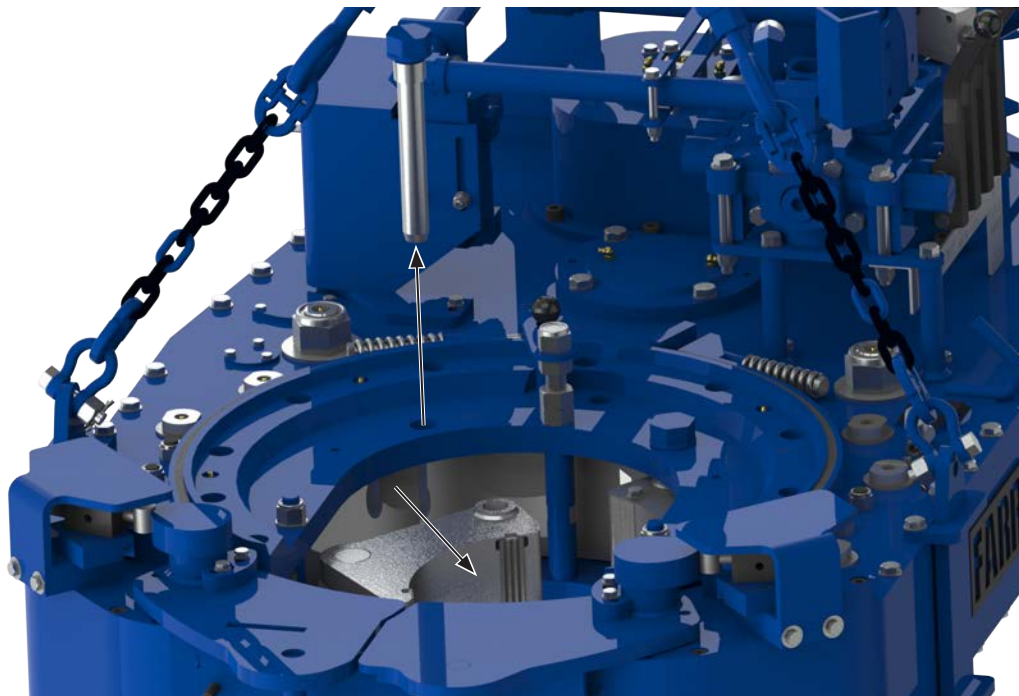
Description	Part Number	Description	Part Number
4-1/2" Jaw Die Kit	1393-JDK-345	9-7/8" Jaw Die Kit	1393-JDK-385
5" Jaw Die Kit	1393-JDK-350	10" Jaw Die Kit	1393-JDK-188
5-1/2" Jaw Die Kit	1393-JDK-355	10-3/8" Jaw Die Kit	1393-JDK-387
6-5/8" Jaw Die Kit	1393-JDK-360	10-3/4" Jaw Die Kit	1393-JDK-390
7" Jaw Die Kit	1393-JDK-365	11" Jaw Die Kit	1393-JDK-393
7-1/2" Jaw Die Kit	1393-JDK-368	11-3/4" Jaw Die Kit	1393-JDK-395
7-5/8" Jaw Die Kit	1393-JDK-370	11-7/8" Jaw Die Kit	1393-JDK-397
7-3/4" Jaw Die Kit	1393-JDK-371	13-3/8" Jaw Die Kit	1393-JDK-400
8-1/4" Jaw Die Kit	1393-JDK-372	13-5/8" Jaw Die Kit	1393-JDK-402
8-1/2" Jaw Die Kit	1393-JDK-373	14" Jaw Die Kit	1393-JDK-405
8-5/8" Jaw Die Kit	1393-JDK-375	14-3/8" Jaw Die Kit	1393-JDK-410
9-5/8" Jaw Die Kit	1393-JDK-380		
Flat Die Insert: 13-0008-500			

2.F.2 Tong Jaw Installation & Removal

The tong jaws will often require removal to change jaw size or replace worn jaw die inserts. Open the tong door to disable tong rotation (rotation is inhibited by safety door systems). Support the jaw being removed from the bottom, and use a wrench to loosen and remove the jaw pivot bolt. Slide the jaw away from the rotary gear towards the centre of the cage plate assembly, and lift clear of the tong (see Illustration 2.F.1). Repeat for the other jaw.



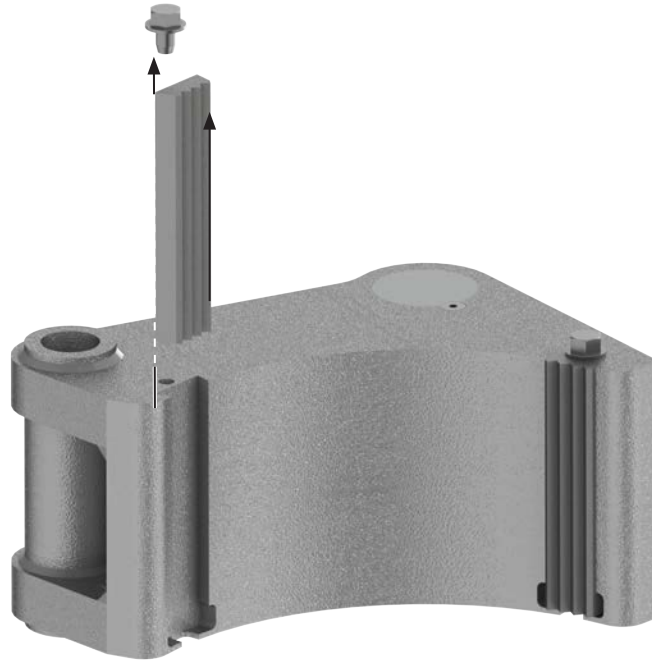
**JAWS MAY PRODUCE METAL SLIVERS. WEAR STURDY GLOVES WHEN REMOVING AND INSTALLING JAW DIE KITS.**



**Illustration 2.F.1: Jaw Removal**

**2.F.2 Tong Jaw Installation & Removal (Continued):**

Once the jaw has been removed, extract the die keeper screws and remove the dies by tapping dies lightly with a hammer. Replace the dies, tapping them into place if necessary, and replace the keeper screws (see illustration 2.F.2). Reverse the process to install or replace jaws.



**Illustration 2.F.2: Jaw Die Removal**

Tong jaws are clearly marked with the size. Ensure the jaw to be installed is the proper size for the pipe to be run. Over-sized or under-sized jaws may result in jaw slippage, or cause the jaws to leave the end of the cam surface on the inside of the rotary gear. Additionally, incorrectly sized jaws will cause the pipe to be off-centre relative to the backup, resulting in eccentric rotation and potential pipe thread damage.

Use of jaws not manufactured by McCoy is not recommended, and may result in jaw slippage jaw failure, or damage to the camming surfaces of the rotary gear.

**2.G TONG RIG-UP & LEVELING****2.G.1 Suspension & Restraint**

Suspend the tong from a location as near to the centre of the drill rotary as possible, and from a location high enough on the mast to ensure easy handling. The lower the point from which the tong is suspended, the more effort will be required to move the tong to and from the connection point.

The suspension line may be extended over a pulley and balanced by a counterweight equal to the weight of the tong, or simply tied off in the derrick to form a dead line. When using a dead line arrangement it is necessary to use a McCoy spring hanger assembly (see specification page for recommended spring hanger). This spring hanger compensates for the downward movement of the casing as the thread is made-up, and imparts additional force to the suspension cable:

- a “single spring” hanger typically applies 420 lbs. (191 kg.) to the suspension line for every inch of thread made up
- a “double spring” hanger typically applies 840 lbs. (382 kg.) to the suspension line for every inch of thread made up

If you do not know which specific spring hanger is in use, check the specification page in this manual for information on the recommended spring hanger for this application. McCoy Global will not guarantee or specify spring hangers other than what has been supplied by McCoy.

Many applications use a lift cylinder for adjusting the height of the tong. Ensure the weight of the lift cylinder is known if it has not been included in the total weight of the tong.

All forces upon the suspension line must be considered when calculating necessary strength of the suspension line. The weight of the tong, the weight of the lift cylinder, the weight of the spring hanger, and the force imparted on the suspension line by the spring hanger must all be added together in order to arrive at the total force supported by the suspension line. Select your suspension line based upon the total force and the margins of safety dictated by the policies of your company and by established engineering practices. Ultimately, calculating the force on the suspension line and selection of the suspension line is the complete responsibility of the customer.

Use of dual backup (snub) lines of strength sufficient to withstand the linear force imparted by the maximum rated torque of the tong is integral to ensuring safety on the drill floor. Use of snub lines of less than sufficient strength poses a significant risk of injury to personnel. Calculate the force on the snub lines by dividing the maximum torque of the tong by the tong's torque arm (expressed in feet). For example, a 50,000 lbs.-ft. tong with a 45-1/2 inch (3.8 ft.) torque arm will generate 13158 lbs. of force against the snub line. Select your snub lines and attachment points based upon the total force and the margins of safety dictated by the policies of your company and by established engineering practices. Ultimately, calculating the force on the snub line and selection of the snub line is the complete responsibility of the customer.

Snub lines must be securely connected to the rear of the tong, and tied off to a suitable anchor. One snub line must be secured to the load cell, which is then secured to the rear of the tong. The side of the tong the load cell connects to is dependant upon whether make-up or break-out activities are underway. To ensure accurate torque measurement, the torque measurement line must be connected perpendicular to the lengthwise axis of the tong, and perpendicular to the hang line (see illustrations 2.H.1 and 2.H.2). Connect the second snub line on the opposite side of the load cell, perpendicular to the lengthwise axis of the tong and perpendicular to the vertical. Installed snub lines should have as little slack as possible when not under load.

When placing tong on the drill floor ensure the surface is level and sturdy enough to support the tong without the risk of toppling.

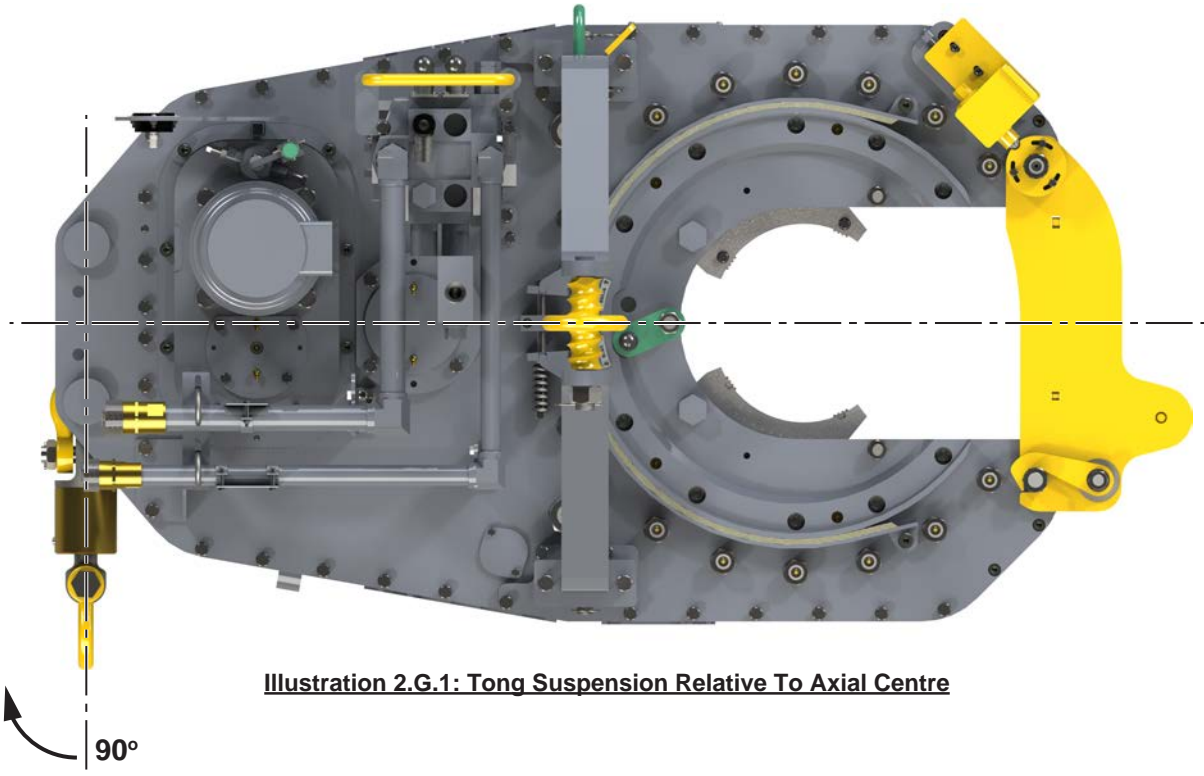


**MCCOY GLOBAL ACCEPTS NO RESPONSIBILITY FOR DESIGNING AND SELECTING AN ADEQUATE SUSPENSION AND RESTRAINT SYSTEM FOR YOUR DRILLING EQUIPMENT. FAILURE TO FOLLOW THE INSTRUCTIONS PROVIDED IN THIS SECTION MAY RESULT IN SERIOUS INJURY TO THE OPERATOR.**

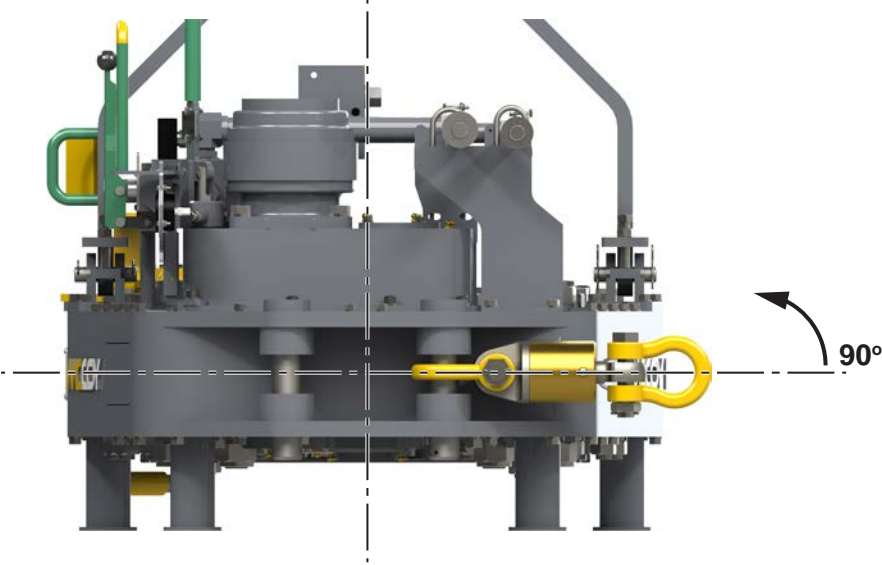


**ALL SELECTED FASTENERS, SHACKLES, CLAMPS, ETC. USED FOR CONSTRUCTING THE SUSPENSION AND SNUB LINES MUST BE RATED FOR THE CALCULATED FORCES.**

2.G.1 Suspension & Restraint (Continued):



**Illustration 2.G.1: Tong Suspension Relative To Axial Centre**



**Illustration 2.G.2: Tong Suspension Relative To Vertical Centre**



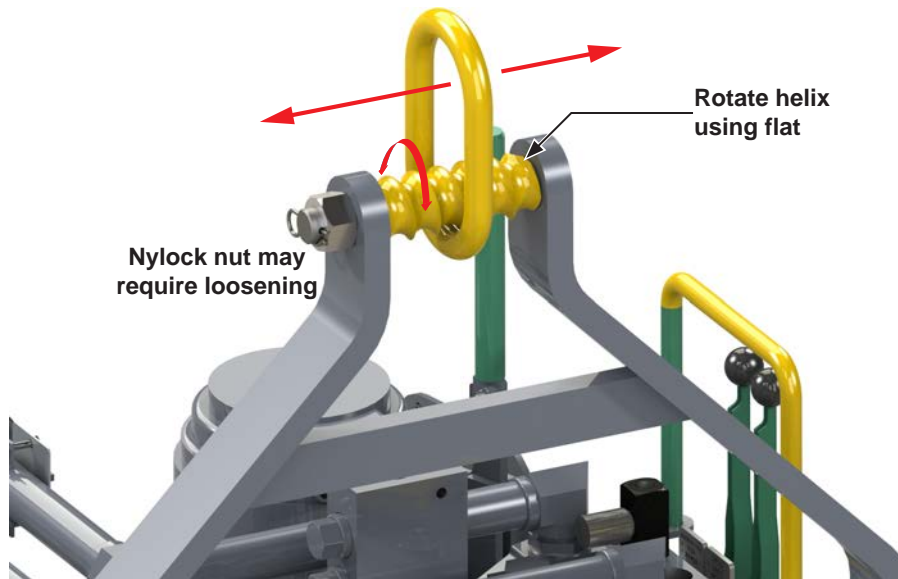
**2.G.2 Tong Leveling**

The tong must be leveled side-to-side and front-to-rear before placing into service. The following guidelines will assist you when leveling your tong.



**FAILURE TO PROPERLY LEVEL TONG MAY RESULT IN JAW SLIPPAGE OR FAILURE OF JAW COMPONENTS**

- i. Place a level axially (side to side) across the tong, ensuring that it is parallel with the surface of the tong. Use a thin wrench on the flat of the adjusting helix to rotate the helix, forcing the lift link to move towards the outer supports of the sling. The 3/4" nylock nut on the pin may have to be slightly loosened to allow the helix to rotate. Adjust the helix until the level shows that the tong is level side-to-side.

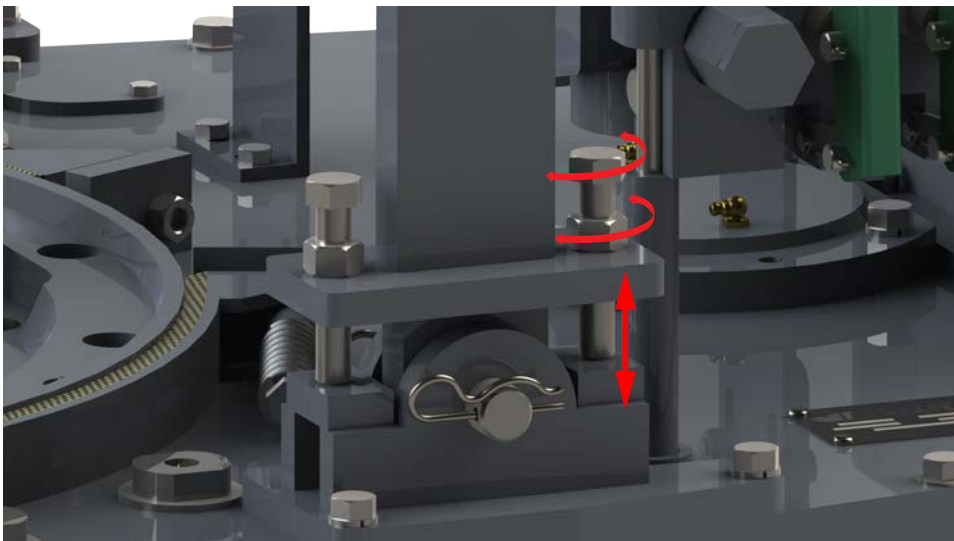


**Illustration 2.G.3: Tong Leveling 01**



**ONLY USE THE MASTER LINK TO SUSPEND THE TONG ASSEMBLY. THE RIGID SLING IS DESIGNED FOR VERTICAL LIFTING ONLY.**

- ii. Place a level lengthwise (front to back) along the tong, ensuring that it is parallel with the surface of the tong. Loosen the 3/4" jam nuts on the adjusting bolts on rigid sling brackets. Completely loosen the adjusting bolts. Turn front or rear adjusting bolt equally on each hanger lug until tong hangs level front-to-back. Lock adjusting bolts in place with the jam nuts.



**Illustration 2.G.4: Tong Leveling 02**

**2.H TONG OPERATION****2.H.1 Operator Training**

Many companies set qualification standards that must be met before equipment may be operated without supervision. McCoy Global recommends operator training, which typically consists of operation of the equipment under the supervision of a trained equipment operator until a satisfactory level of competence is achieved. Typical operator training should include:

- Introduction to and general description of equipment
- Technical specifications and performance data
- Operating instructions
- Control systems and interlocks
- Operating hazards
- Checks and inspections

**2.H.2 Operator Safety**

McCoy recommends that a hazard assessment of the work area be performed by a designated safety representative before commencing operations. A designated safety representative is responsible for verifying that all operators have adequate equipment and safety training.

The safety door system is the primary device protecting the tong operator and nearby personnel from the rotary gear. Confirm the correct operation of the safety door before every job. Never disable the safety door device.

**NEVER DISABLE OR BYPASS THE TONG SAFETY DOOR SYSTEM**

The area surrounding the tong operating area must be clutter-free and free from tripping hazards, or protruding objects that may snag hydraulic hoses on the tong, backup, lift cylinder, or torque measurement system. Operating surface or drill floor must be kept free of slipping hazards like grease, oil, water, etc.

Adequate lighting of the work area is required. All warnings, labels, gauges, and signs must be clearly visible

The components of the tong commonly manipulated or requiring control input are painted green, and are safe for continuous handling. Areas painted yellow are designated as hazardous areas, and contact with those areas must be avoided during operation. Always wear all personal protective equipment (PPE) specified by your company's HSE policy, and follow all of your company's safety guidelines.

**ALWAYS WEAR APPROVED PERSONAL PROTECTIVE EQUIPMENT (PPE) WHEN OPERATING HYDRAULICALLY-POWERED EQUIPMENT.**

Ensure hydraulic power is deactivated and tong hydraulics are de-pressurized before disconnecting the main hydraulic lines. McCoy recommends depressurizing the tong hydraulic system before connecting or disconnecting quick-connect fittings.

**DEPRESSURIZE EQUIPMENT BEFORE DISCONNECTING MAIN HYDRAULIC LINES.****2.H.3 Valve Operation**

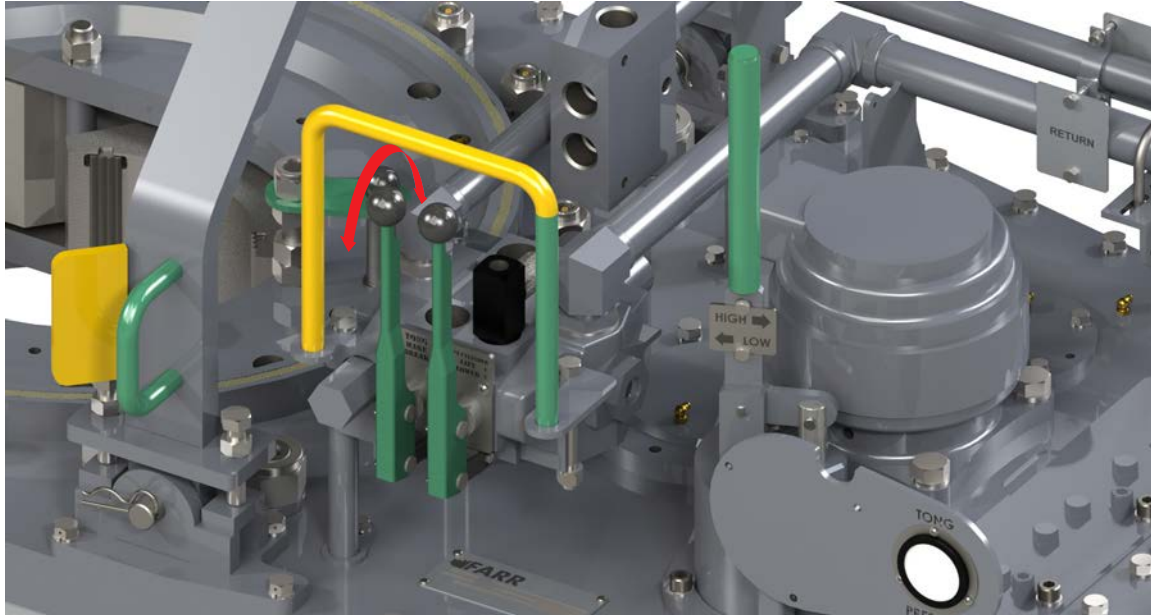
4-way proportional valves control operation of hydraulic devices on the tong assembly such as hydraulic motors and cylinders. When any one valve is "centered" or in the detent position, there is no hydraulic output from the valve. When the valve is pushed forward there is an effect, and when the valve is pulled back, there is an opposite effect. These valves feature proportional control, which means that further extension of the valve handle (thereby further opening the valve orifice) results in proportionally higher hydraulic output to the controlled device.

The following illustrations demonstrate the type and effect of the hydraulic valves with which this tong is may be equipped.



**2.H.3 Valve Operation (Continued):****TONG MOTOR**

This is a proportional valve. Pushing the valve handle forward will cause the tong motor to rotate in a clockwise direction (as seen from the top of the tong). This is the desired direction of rotation for making up a joint. Pulling the valve handle in the opposite direction results in counter-clockwise rotation, which is the desired direction of rotation for breaking out a joint. Releasing the valve handle will cause the tong to immediately stop rotation.

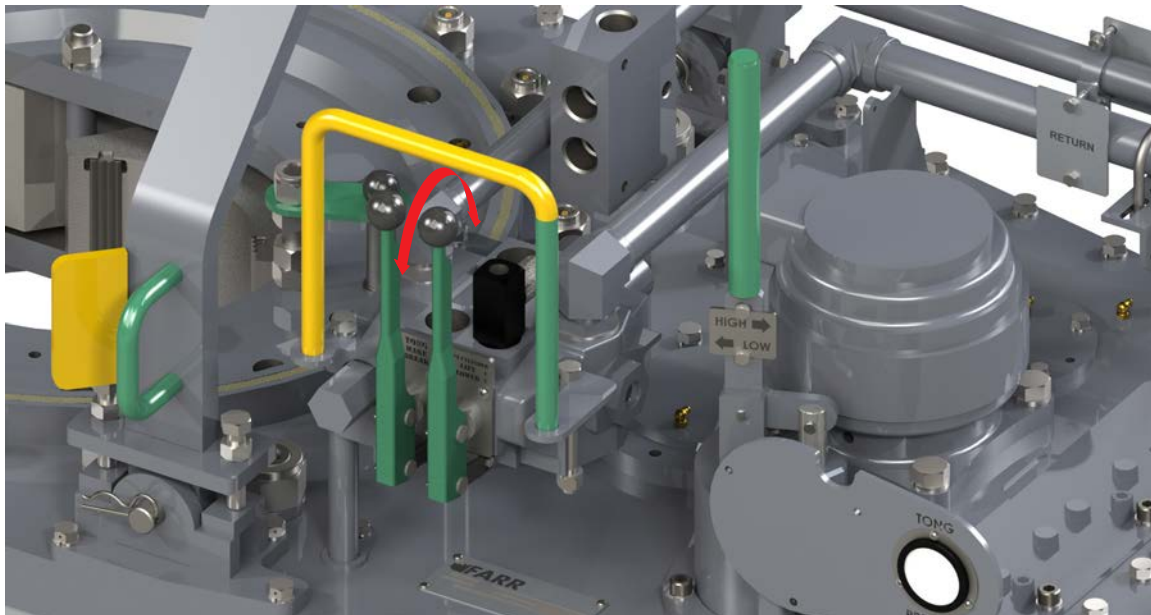


**Illustration 2.H.1: Tong Rotation Control Valve**

**LIFT CYLINDER CONTROL VALVE**

This is a direct-acting valve. Pulling out on the valve handle will cause the lift cylinder to lift the tong vertically. Pushing in on the valve handle will cause the lift cylinder to lower the tong. Releasing the valve handle will immediately stop the lifting or lowering action.

The needle valve on the discharge of the control valve regulates hydraulic fluid flow to the lift cylinder. Closing the needle valve (rotating the knob clockwise) will increasingly restrict the flow rate of the fluid, resulting in slower actuation of the cylinder in both directions (lifting & lowering).



**Illustration 2.H.2: Tong Lift Cylinder Control Valve**

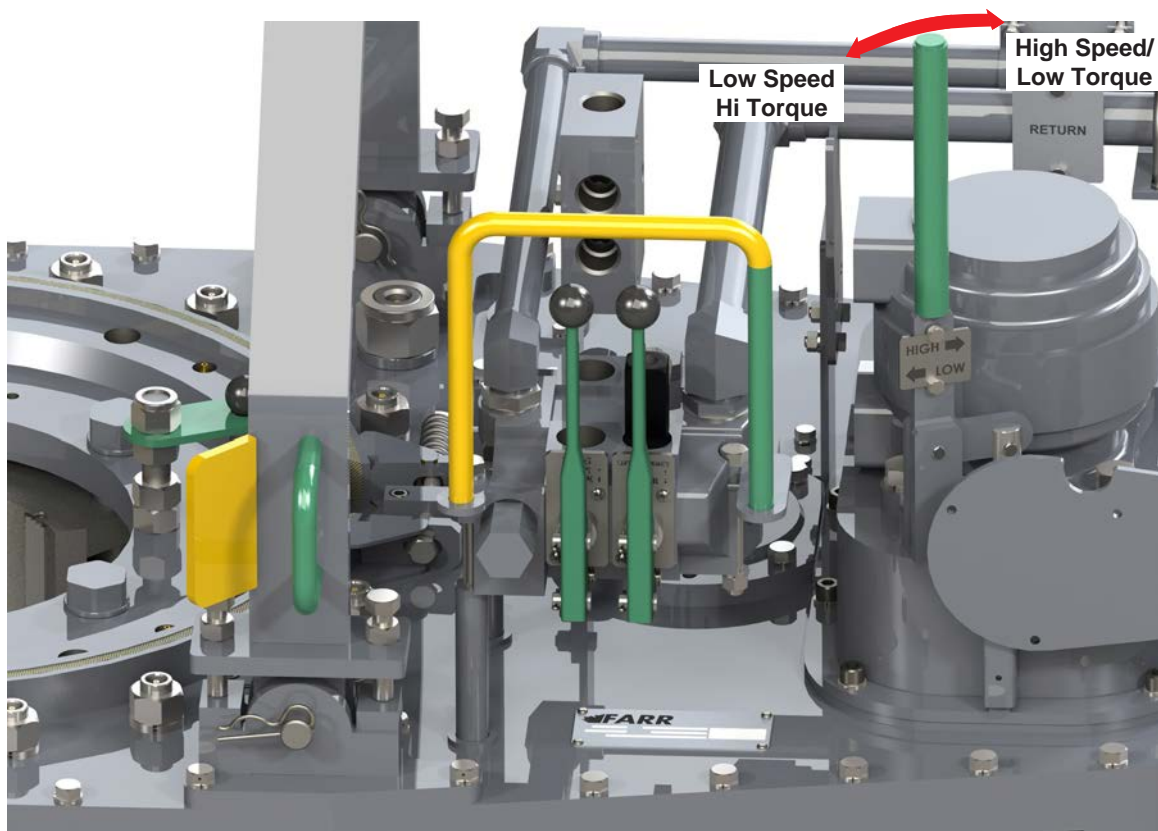
### 2.H.4 Shifting Gears

The shifting shaft has three “detent” positions identifying the low speed/high torque position, the “neutral” or free-spinning position, and the high speed/low torque position. The detent strength may be adjusted by releasing the locknut on the detent tube and increasing or relaxing pressure on the detent spring. Ensure the locknut is tightened once the desired detent pressure has been set.

To shift to the high-speed gear, move the shifting handle toward the rear of the tong, forcing the shifting shaft down. To shift to the low-speed gear, move the shifting handle towards the front of the tong, forcing the shifting shaft up. Note that the high clutch gear or the low clutch gear may not be exactly aligned when shifting, so the operator may need to “bump” the motor control handle slightly to turn the main clutch gear shaft and shifting collar into alignment. This is most effective when applying a small amount of pressure on the gear shift lever in the direction you want to shift the tong, ensuring the shifting collar will “catch” when the main clutch gear aligns with either the high or low clutch gear.



**SHIFTING TONG WHILE ROTATING THE MOTOR AND CAGE PLATE MAY RESULT IN CATASTROPHIC GEAR TRAIN FAILURE**



**Illustration 2.H.3: Tong Manual Shift Control**

### 2.H.5 Pre-Operational Checks

McCoy recommends that the following pre-operating tests be performed prior to releasing the tong assembly to a operational environment:

1. Connect the tong to a hydraulic power source in a controlled environment. Ensure the power unit's operating parameters are within the specifications as identified on Pg. 1.6. Ensure the hydraulic connections from the power unit are properly and securely made up (see Section 2.E.3). Do not neglect to connect the motor drain line.
2. Start the power unit as specified by the power unit operator's manual. Open the Bypass Valve on the hydraulic system, and inspect all pressure and return line hose connections to ensure correct and secure installation. A restriction in the pressure supply hose will result in high pressure within the power unit hydraulic system, which will activate the hydraulic governor and increase the engine speed to as high as maximum RPM. A restriction in the return line will result in high pressure within the power unit and the tong hydraulic system, causing engine speeds as high as maximum RPM, and possible failure of the motor seal.

## 2.H.5 Pre-Operational Checks (Continued):



**A CLEARLY IDENTIFIED REMOTE POWER PACK EMERGENCY STOP MUST BE INSTALLED IN THE IMMEDIATE VICINITY OF THE TONG OPERATOR.**

3. Allow hydraulic system to warm by circulating fluid for about 10 minutes, then slowly close the bypass valve to allow hydraulic fluid to circulate through the hoses and tong. Ensure circulating pressure does not exceed 200 psi.
4. Inspect all hydraulic hoses and connections on the tong. Immediately correct any hydraulic fluid leaks.
5. Inspect all gauges. Replace leaking or cracked gauges, or any gauge not registering a reading.
6. Confirm that all load-bearing pins and R-clip retainers are installed and in good condition (rigid sling pins, lift cylinder pins).
7. Confirm all hydraulic hoses (with the exception of the supply & return to the backup) are securely fastened to the tong, and are not in contact with the cage plate or creating a snagging hazard.
8. Test the tong door sensor/shutdown (safety door) system. The safety door system is an integral safety feature that must not be bypassed or disabled. Operating the power tong with a malfunctioning or non-operating door sensor/shutdown system exposes the operator and rig personnel to potentially fatal injury. Do not operate tong with a malfunctioning or non-operating door sensor/shutdown system. Routinely testing the sensor/shutdown system operation before mobilizing and at each shift change ensures protection of drill floor personnel.

A rotating tong potentially stores a large amount of kinetic energy in the gear train. Testing the sensor/shutdown system by suddenly opening the tong door to stop rotation will generate a shock load that could result in catastrophic equipment failure not covered by the manufacturer's warranty, and may present a hazard to personnel on the drill floor. The following procedure outlines the correct, safe procedure for testing the door sensor/tong shutdown system on a McCoy power tong.

Using the correct testing procedure ensures the sensor/shutdown system is fully functional without exposing the equipment to a shock load or personnel to a potential hazard. The tests also verify that the shut down valve is positively sealing and rules out the possibility that contaminated hydraulic fluid or erosion is preventing the valve from completely shutting off the motor's supply of hydraulic fluid.

- i. Shift the tong to low gear (see Section 2.H.3).
- ii. Stop all tong rotation.
- iii. Open the tong door.
- iv. Gradually attempt to turn the tong using the rotation control handle. Continue to gradually move the handle until the valve is fully stroked, and hold for 30 seconds. Verify the ring gear does not rotate while the rotation control is engaged. PROCEDURAL NOTE: a very small amount of ring gear movement is acceptable as the cartridge valve seats to stop rotation.
- v. Release the valve handle and allow the valve to go to the neutral position. Gradually attempt to turn the tong in the opposite direction until the valve is fully stroked, and hold the handle in the fully stroked position for 30 seconds. Verify the ring gear does not rotate while the rotation control is engaged. PROCEDURAL NOTE: a very small amount of ring gear movement is acceptable as the cartridge valve seats to stop rotation.
- vi. Ensure tong door is fully opened. Move the rotation control handle to approximately 50% of its full stroke. Have an assistant slowly close the tong door while continuing to hold the directional control valve at 50%. Rotation should commence only once tong door is fully closed.

If the safety door does not operate as designed, the safety door switch may require adjustment, or further troubleshooting of the safety door system may be required. See Section 3.F.4 for safety door switch adjustment procedures, and Section 4.D for safety door troubleshooting instructions.

The safety door switch is protected from impact by a sturdy metal guard, painted yellow. This guard must be inspected before each use of the tong. All components of the guard must be in place, and all fasteners securing the guard must be intact and tight. Ensure wire ties (where applicable) on safety door components are present and secure, and do not show signs of tampering.



**DO NOT OPERATE TONG WITH A MALFUNCTIONING OR NON-OPERATING SAFETY DOOR SYSTEM.**

**2.H.6 General Comments**

1. Position rotary gear in contact with both idler gears when breaking out joints or collars where high torques are required.
2. When making-up integral (shouldered) joints, it is essential to make up the last turn of the threads in low gear. This reduces the tendency of an instant stop or a sudden increase in torque, which induces extremely high stresses on the gear train.
3. DO NOT employ the “snap break” method of breaking-out joints when pulling a string. The extremely high stress placed on the gear train frequently causes gear breakage.



**THE “SNAP-BREAK” METHOD OF BREAKING CONNECTIONS IS HAZARDOUS TO RIG PERSONNEL AND EQUIPMENT**

**2.I MAKING AND BREAKING CONNECTIONS**

**THESE OPERATING PROCEDURES ASSUME THE USER HAS PROPERLY SET UP AND PREPARED THE EQUIPMENT FOR OPERATION AS PER SECTIONS 2.D, 2.E, 2.F, & 2.G OF THIS MANUAL.**

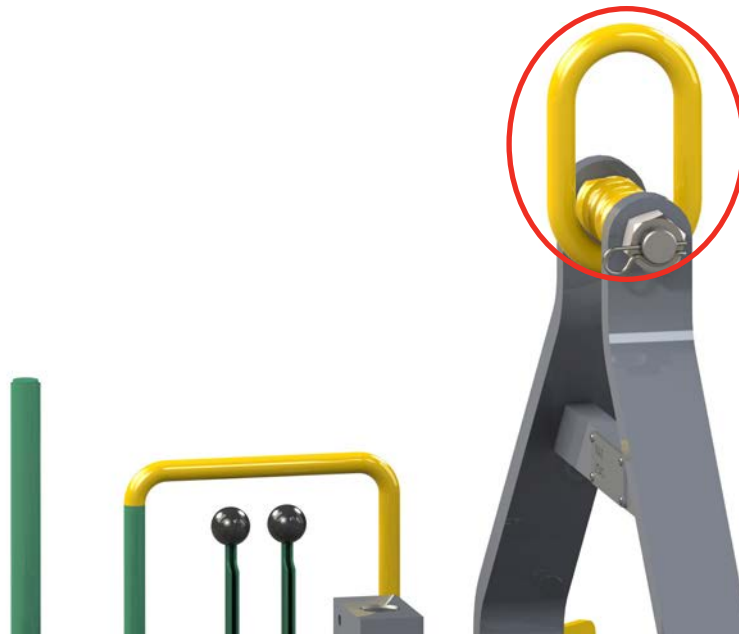
Set up and prepare your equipment for operation as per Section 2 of this manual Refer to the following sections:

- 2.D - Lift Cylinder Installation
- 2.E.3 - Hydraulic Connections
- 2.F - Tong Jaw Installation
- 2.G.1 - Tong Rig-up and Leveling (Suspension)
- 2.G.2 - Tong Rig-up and Leveling (Leveling)

Your tong and backup assembly should be properly suspended, connected to a hydraulic power source, and ready to make or break connections at this point.

**2.I.1 Making A Connection**

1. Ensure hydraulic power supply to the tong is energized. The master link on the rigid sling must be used to suspend the tong. Do not suspend the tong from any other point.



**Illustration 2.I.1: Master Lifting Link**



**THE MASTER LINK MUST BE USED TO SUSPEND THE TONG ASSEMBLY**



## 2.1.1 Making A Connection (Continued):

2. Ensure the backing pin is in the “makeup” position. From the front of the tong, the backing pin correctly configured for makeup will be in the 10 o'clock position (see Illustration 2.H.2 next page). If it is not, simply lift up and place in the correct position. The cage plate opening must be aligned with the door opening when setting the backing pin position.



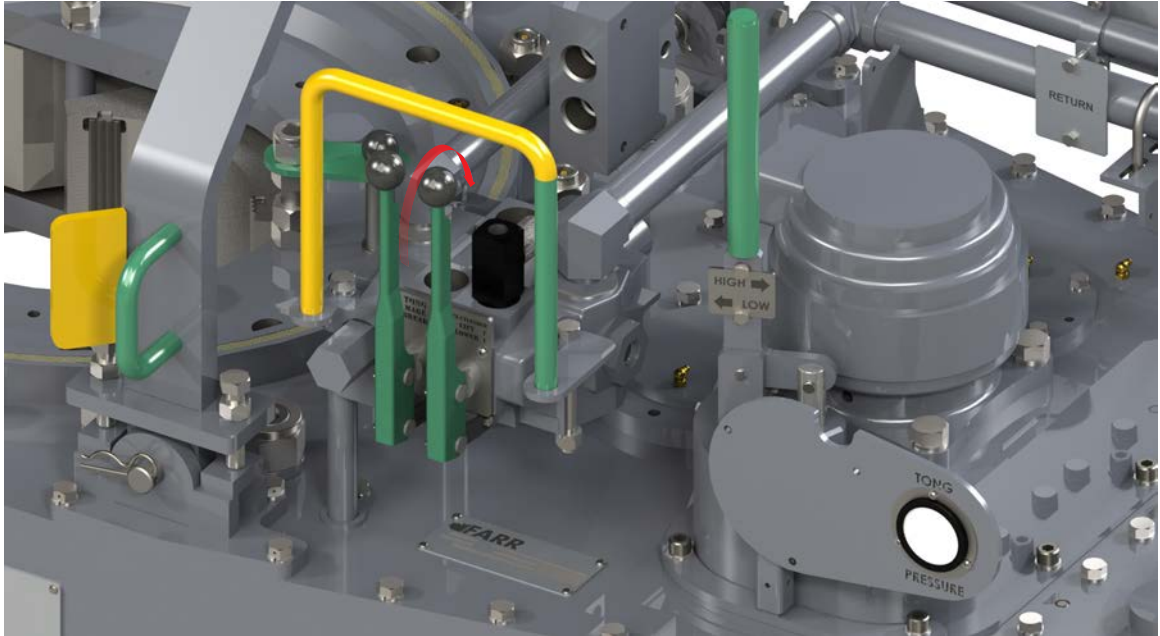
**Illustration 2.1.2: Backing Pin Set To “Make-up” Position**

3. Ensure the load cell and snub line(s) are properly configured for making up connections. A “snub line” is a length of wire rope that connects the rear of the tong body to a sturdy anchor on the drill floor (see Section 2.G.1). The snub line prevents the tong body from spinning in the opposite direction of the cage plate when torque begins to build in the joint. McCoy Global recommends using two snub lines when running the equipment to eliminate uncontrolled movement in either rotational direction. The snub line(s) must be rated for the applied torque plus whatever safety margins stated by your own operating policies. The snub line connection point on the drill floor must be sturdy enough to absorb all applied forces when making up the joints. When making up joints the load cell must be connected to the driller’s side of the tong, which is the left side of the tong as seen from the rear. For accurate torque measurement the snub line between the tong body and the anchor must be perpendicular to the vertical, and perpendicular to the centre-line of the tong.
4. Actuate the lift cylinder control valve to lift the assembly from the drill floor. Pulling the valve handle toward the operator will retract the lift cylinder to lift the assembly (see Illustration 2.1.3 next page). Note that rig personnel are required to stabilize the tong and backup as it is being lifted so it does not swing and collide with other rig equipment.



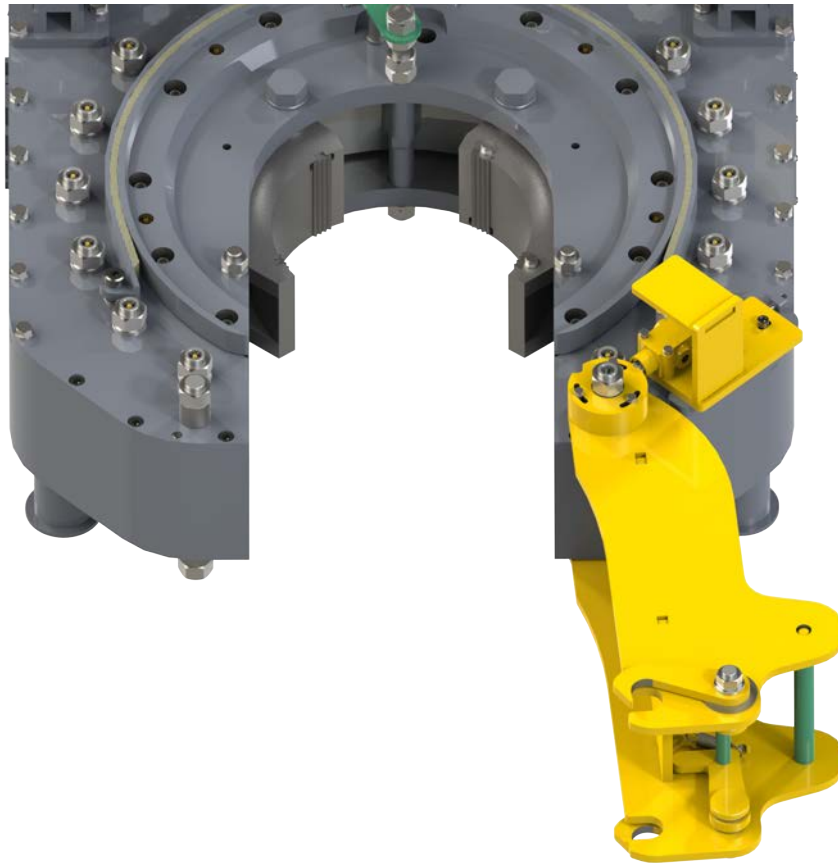
**RIG PERSONNEL MUST STABILIZE THE TONG AS IT IS LIFTED FROM THE DRILL FLOOR**

## 2.1.1 Making A Connection (Continued):



**Illustration 2.1.3: Lift Cylinder Control (Raise)**

5. Grasp the tong door handles and pull firmly to open. Since your equipment is equipped with safety doors, opening the door will inhibit rotation of the cage plate.



**Illustration 2.1.4: Opening Tong Doors**

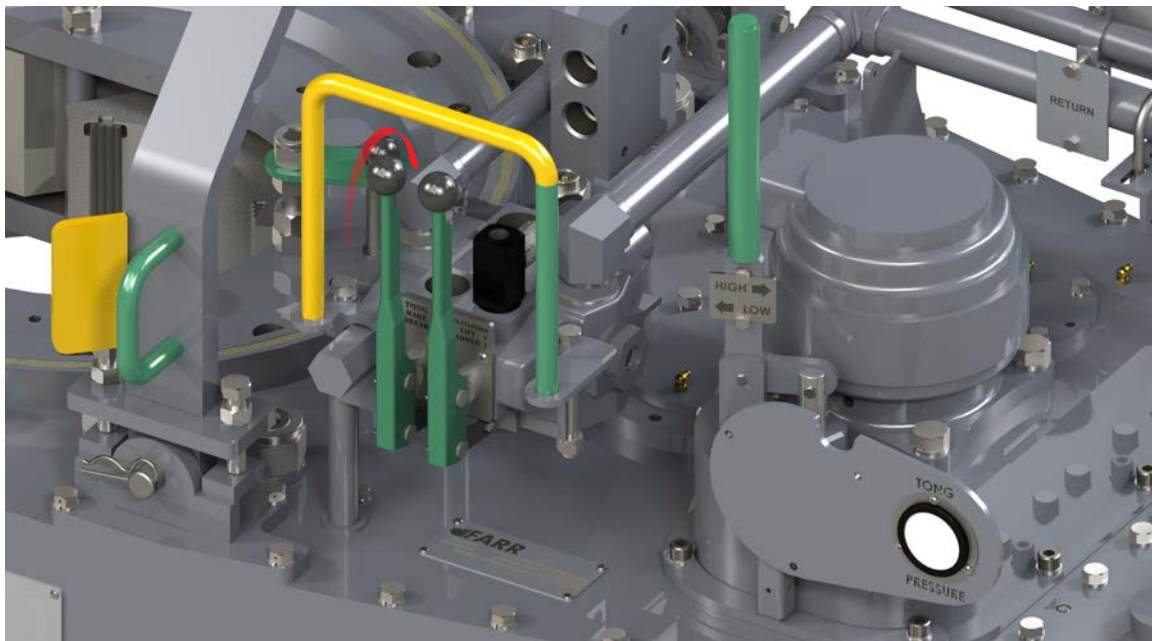
**2.1.1 Making A Connection (Continued):**

6. Manually engage the threads of the tubing connection being made up. Ensure threads are not cross-threaded.
7. Move the tong on to the tubing joint. Use the lift cylinder to ensure the tong jaws are at the correct location above the connection joint.
8. Firmly close the LH tong door, followed by the RH tong door. Tug firmly on the LH door handle to ensure the latch is firmly engaged.
9. Ensure tubing is roughly centered within the tong jaws - rig personnel are required to stabilize the tong above the connection until the jaws have been cammed on to the pipe or casing.
10. Begin rotation with the tong in high gear (high speed/low torque). See Section 2.H.4 to properly set the tong to high gear. Do not shift gears while the tong is rotating.



**SHIFTING TONG WHILE ROTATING THE MOTOR AND CAGE PLATE MAY RESULT IN CATASTROPHIC GEAR TRAIN FAILURE**

11. Push the motor control valve toward the tong to rotate the cage plate in the make-up direction.

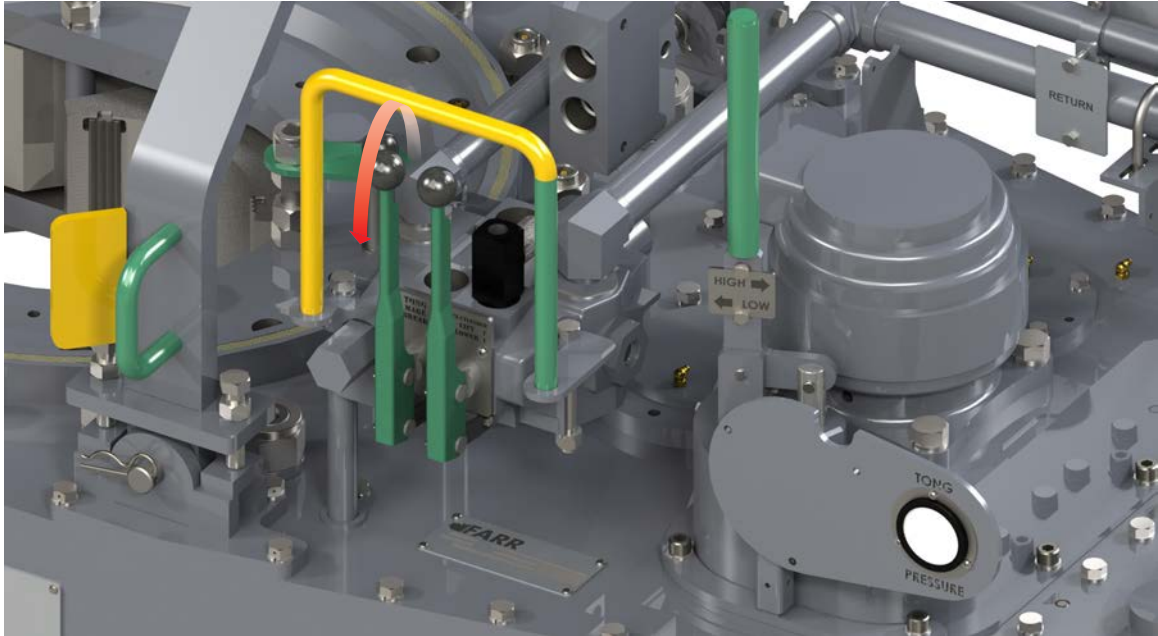


**Illustration 2.1.5: Motor Control - Make-up**

12. When the tong jaws cam on to the tubing push the rotation control handle all the way in to thread the connection together at high speed. As the joint becomes fully made up the increasing torque demand will stall the motor, and displayed torque will increase.
13. Stop rotation, and set motor to low speed and shift to low gear (low speed/high torque). See Section 2.H.4 for instructions for shifting to low gear. This will enable the tong to produce adequate torque for making up the joint to specification.
14. Push the rotation control handle all the way in to complete the connection at low speed/high torque. Observe the torque gauge - when the specified make-up torque is reached stop rotation. Reverse the rotation control valve to release the tong jaws from the tubing (see Illustration 2.1.6).

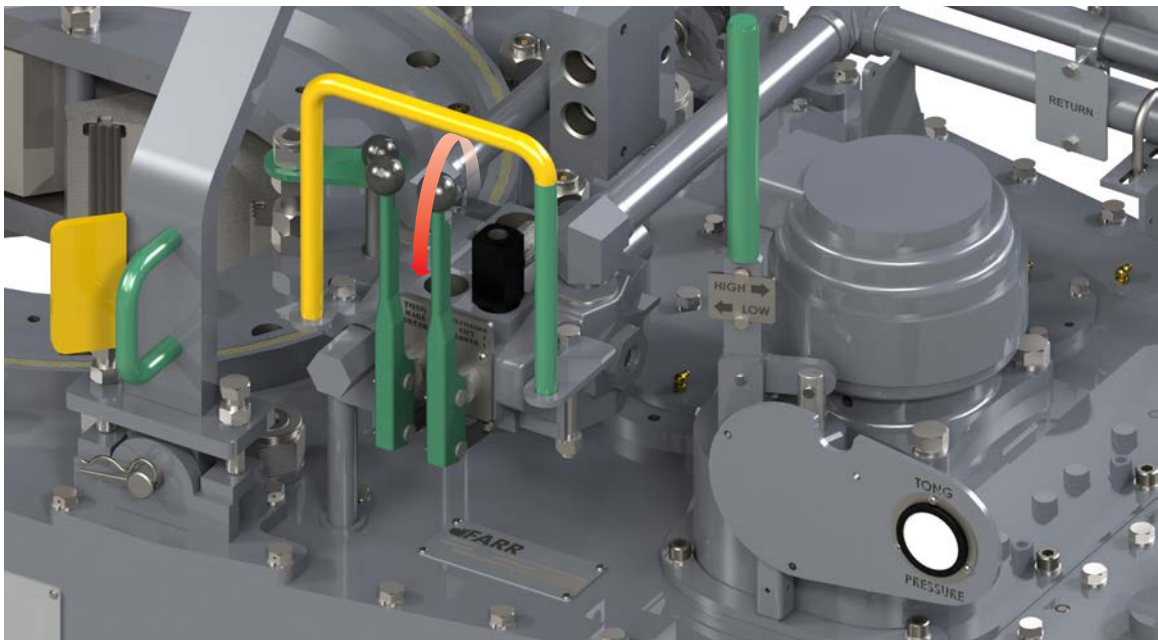


## 2.1.1 Making A Connection (Continued):



**Illustration 2.1.6: Motor Control - Releasing Jaws**

15. When tong jaws are free align the opening in the rotary gear with the mouth of the tong, and open the tong doors to free the tong from the drill string. Note that rig personnel may be required to stabilize the tong as it completely releases from the drill string. Guide the tong away from the string and use the lift cylinder control to lower it to the drill floor if desired.



**Illustration 2.1.7: Lift Cylinder Control - Lower**

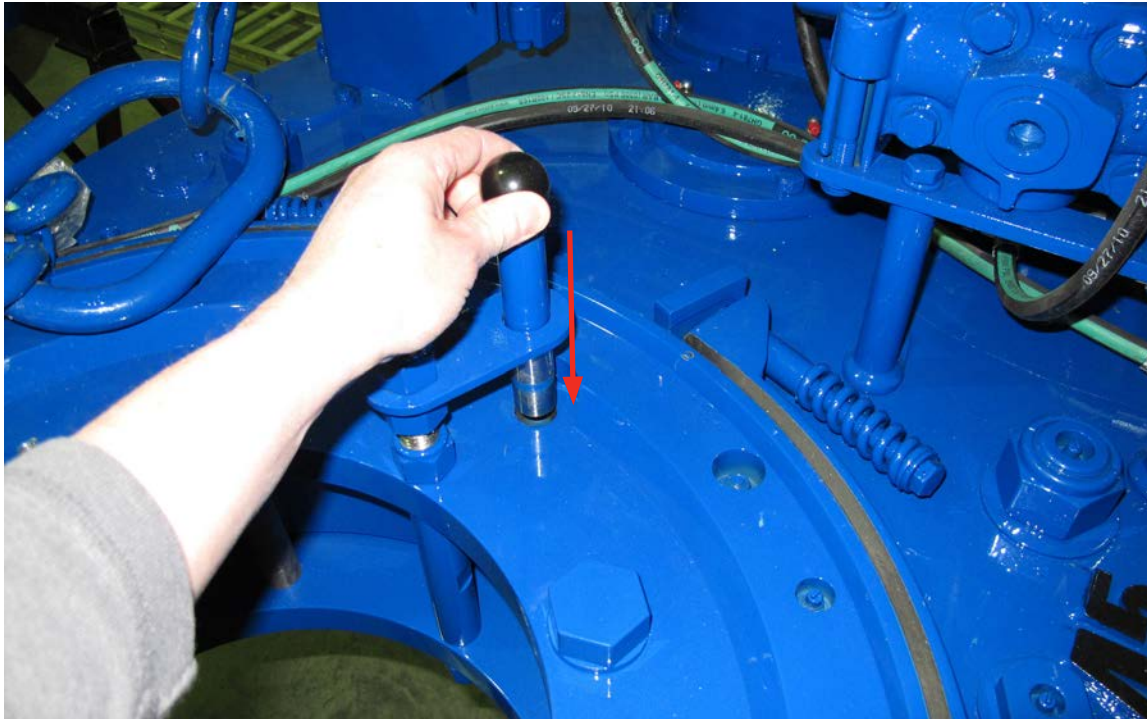
16. Repeat steps 6 through 15 until the desired number of connections are made up.

## 2.1.2 Breaking A Connection



**YOUR TONG SHOULD BE PROPERLY SUSPENDED, CONNECTED TO A HYDRAULIC POWER SOURCE, AND READY TO BREAK CONNECTIONS.**

1. Ensure hydraulic power supply to the tong and backup is energized. The master link on the rigid sling must be used to suspend the tong. Do not suspend the tong from any other point. See Illustration 2.1.1.
2. Set the backing pin for “breakout” operation. Lift up on the backing pin and rotate it to the “breakout” position, which is 2 o’clock as seen from the front of the tong. The opening in the rotary gear must be aligned with the tong door opening in order to properly set the backing pin (see Illustration 2.1.8).



**Illustration 2.1.8: Setting Backing Pin To “Break-Out” Position**

3. Ensure the load cell and snub line are configured for break-out operation. The load cell must be transferred to the off-driller’s side (the right hand side as seen from the rear of the tong), and the snub line must be transferred to the driller’s side to perform break-out operations.
4. Open the tong doors (see Illustration 2.1.4).
5. Actuate the lift cylinder control valve to lift the assembly from the drill floor if necessary. Pulling the valve toward the operator will retract the lift cylinder to lift the assembly (see illustration 2.1.3). Note that rig personnel are required to stabilize the tong and backup as it is being lifted so it does not swing and collide with other rig equipment.

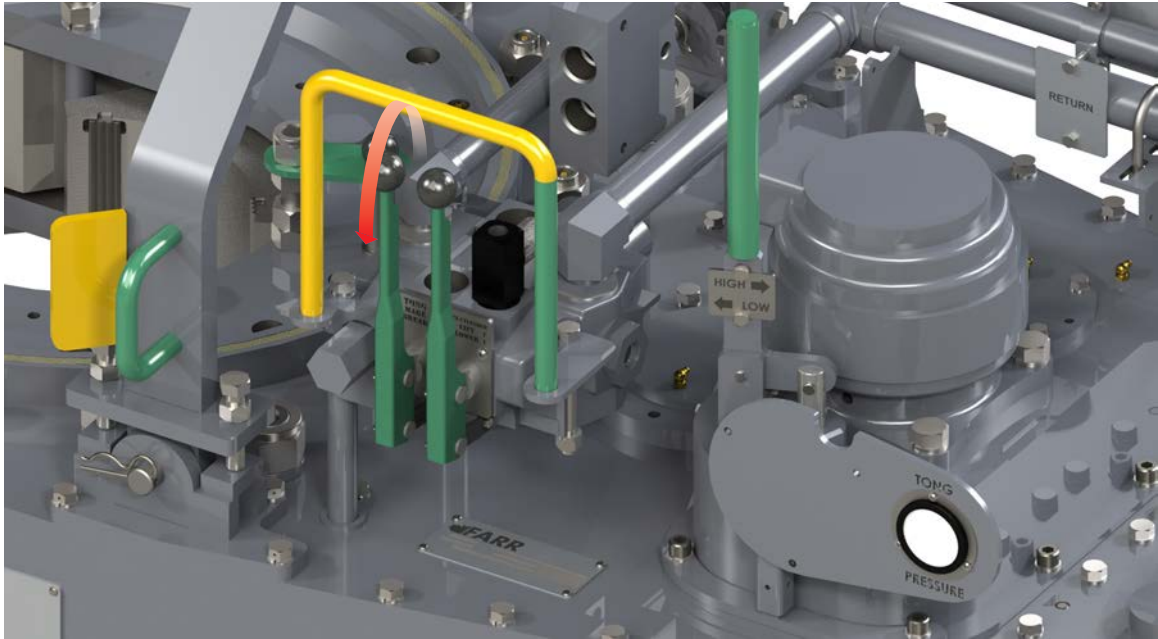


**RIG PERSONNEL MUST STABILIZE THE TONG AS IT IS LIFTED FROM THE DRILL FLOOR**

6. Move the tong on to the tubing joint. Use the lift cylinder to ensure the tong jaws are at the correct location above the connection joint.
7. Firmly close the tong door against the latch post.
8. Ensure tubing is roughly centered within the tong jaws - rig personnel are required to stabilize the tong above the connection until the jaws have been cammed on to the pipe or casing.
9. Breakout torque is only available when tong is in low gear. See Section 2.H.4 for instructions on shifting your tong to low gear. Do not shift gears while the tong is rotating.

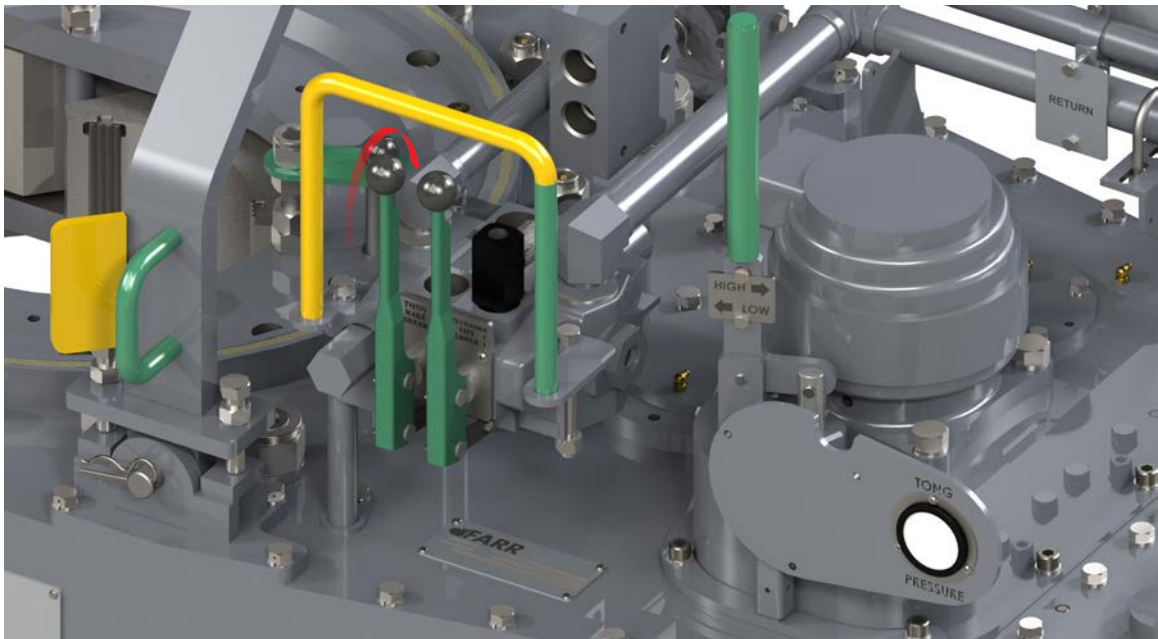
## 2.1.2 Breaking A Connection (Continued):

10. Pull the motor control valve toward the operator to rotate the cage plate in the break-out direction.



**Illustration 2.I.9: Rotation Control - Break-Out**

11. When the tong jaws cam on to the tubing pull the rotation control handle all the way out to break the connection.
12. When the connection breaks stop rotation and shift to high gear (see Section 2.H.4 to shift to high gear). This will enable the tong to completely un-thread the connection at high speed.
13. Pull the rotation control handle all the way out to completely un-thread the connection. Reverse the rotation control handle (push toward tong) to release the tong jaws from the tubing (see Illustration 2.I.10).

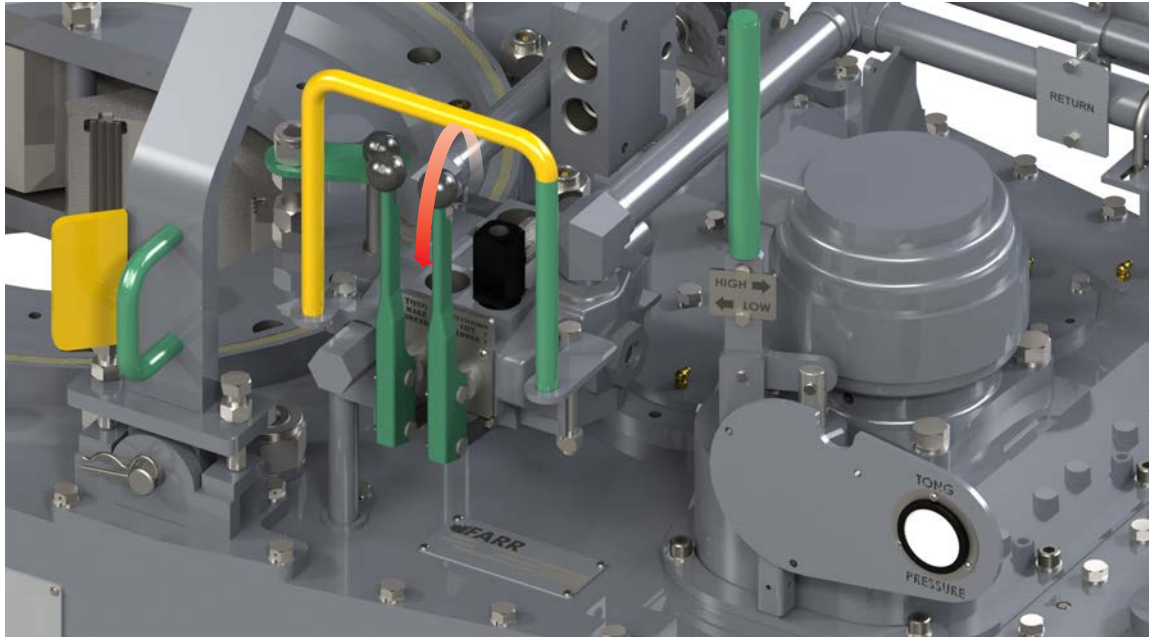


**Illustration 2.I.10: Releasing Tong Jaws Following Break-out & Un-threading**



**2.1.2 Breaking A Connection (Continued):**

14. When the tong jaws disengage align the opening in the rotary gear with the mouth of the tong, and open the tong door to free the tong from the drill string. Unlatch and open the tong door to free the assembly from the tubing. Note that rig personnel may be required to stabilize the equipment as it completely releases from the tubing. Guide the assembly away from the string and use the lift cylinder control to lower it to the drill floor if desired.



**Illustration 2.1.11: Lowering Tong Using Lift Cylinder Control**

15. Use your rig's standard pipe handling procedures to remove and rack the freed tubing stand.
16. Repeat steps 5 through 15 as many times as necessary to break out and un-thread the desired number of connections.

**2.J EXTREME COLD WEATHER OPERATION PROCEDURES**

- 1) Consult the power unit engine operator's manual for all cold weather operating procedures and precautions.
- 2) Select gear and bearing lubricants that are compatible with expected climatic conditions.
- 3) Select hydraulic fluid that is compatible with expected climatic conditions.
- 4) Allow hydraulic fluid to circulate for approximately 20 minutes after starting the power unit, prior to activating the bypass valve to allow fluid to circulate to tong. If the power unit is equipped with an oil temperature gauge, ensure that the fluid has reached operating temperature as specified by hydraulic fluid data sheet.
- 5) Allow for adequate drying of moisture (prior to lubricating) when cleaning tong parts in cold weather.



## SECTION 3: MAINTENANCE



**This page intentionally  
left blank**

McCoy Global recognizes that minor on-site repairs and modifications are required to maintain peak operating condition of your equipment, or to match your equipment with the operating environment. Examples of minor repairs are

- replacement of damaged hydraulic hoses and fittings.
- replacement of malfunctioning pressure gauges and valves.
- replacement of door cylinders
- replacement of fasteners

Any replaced component must be an identical component supplied by McCoy Global. Replaced fasteners must be Grade 8 or equivalent, or whatever fastener is specified by McCoy.

### 3.A GENERAL MAINTENANCE SAFETY PRACTICES

The practices identified here are intended as a guideline. All personnel are responsible for performing their tasks in a manner that ensures worker, equipment, and environmental safety, and may require taking additional steps that are not identified in this section.

Equipment maintenance shall be performed only by designated qualified maintenance personnel. Wear approved eye wear and footwear, and follow all of your company's safety guidelines. Do not begin a maintenance task without the proper tools or materials on hand, or the proper drawings and documentation necessary.

Schedule planned maintenance with operators to avoid conflicts, unnecessary downtime, and the danger of accidental equipment activation. Notify operations when maintenance procedures are complete and equipment functionality is restored.

Isolate the location of the maintenance under way to prevent unaware personnel from inadvertently exposing themselves to a hazard. Use tape, rope, or signage to clearly indicate "off-limits" area.

Replacement of large, heavy individual parts and/or heavy structural components must be performed using an approved lifting device of sufficient lifting capacity. Use care when attaching the lifting device, and safeguard area to avoid endangering personnel or equipment.

All spare parts must meet or exceed OEM specifications in order to maintain equipment integrity, especially protective equipment

Ensure your equipment is isolated from hydraulic power before commencing maintenance operations.



### **DO NOT PERFORM MAINTENANCE UNTIL TUBULAR CONNECTION EQUIPMENT HAS BEEN COMPLETELY ISOLATED FROM HYDRAULIC POWER**

Your equipment uses materials that may be harmful to the environment if improperly disposed of (hydraulic fluid, grease, etc.). Dispose of all materials according to your company's proscribed environmental protection regulations.

### 3.B CLEANING

Clean tong thoroughly cleaned with a good petroleum-based cleaning agent after each job, prior to storage. McCoy Global recommends that the motor and valve assembly be periodically removed, along with the top tong plate, so that guides, rollers and gears can be properly cleaned (see Section 3.H, Overhaul). Ensure that cleaning solvents and chemicals are captured to prevent environmental contamination, and dispose of all materials according to your company's proscribed environmental protection regulations.

### 3.C PREVENTIVE MAINTENANCE PRACTICES

Regular maintenance programs are necessary, and must be established to assure safe, dependable operation of your Hydraulic Tubular Connection System and to avoid costly breakdown maintenance. The following maintenance procedures provides information required to properly maintain your equipment. Your equipment may require more, or less maintenance depending upon the frequency of use and the field conditions under which your equipment operates. These maintenance procedures are designed for equipment operating at 10°C to 35°C ambient temperature for 10 hours per day. McCoy recommends that the inspection and maintenance procedures in this section be performed as recommended in the maintenance checklists (see Appendices), or in conjunction with your maintenance foreman's experience and best estimate of when your equipment is due for this maintenance.

Manufacturers of purchased components included with your hydraulic tubular connection equipment (for example: motors, valves, etc.) may specify maintenance tasks and intervals over and above what McCoy recommends as part of their recommended procedures. Users of this equipment may choose to perform or ignore these additional tasks at their discretion.

Filtration of the hydraulic fluid must be 10 microns or better. Premature fouling of particulate filters within your prime mover or ancillary hydraulic power unit requires immediate hydraulic fluid laboratory analysis to prevent premature wear of hydraulic system due to high levels of wear metals in the fluid.

McCoy Global recommends tracking all maintenance activity including the lubrication schedule and replacement of hydraulic hoses. This may be a simple as keeping a paper log, or using a software-based maintenance tracking utility. A maintenance log is a valuable tool that can be used for easily retrieving maintenance history or identifying trends that require correction.



**3.D HYDRAULIC SYSTEM DE-PRESSURIZATION**

McCoy Global recommends that the hydraulic system be de-pressurized prior to maintenance on any hydraulic component. Perform the following steps to ensure the dangers posed by hydraulic fluid under pressure are minimized.



**ENSURE ADEQUATE CONTAINMENT IS IN PLACE TO PREVENT ENVIRONMENTAL CONTAMINATION FROM RESIDUAL HYDRAULIC FLUID**

- 1) Rotate the tong to the “open throat” position. Ensure tong and backup doors (if equipped) are closed. Fully extend the lift cylinder
- 2) De-energize the power unit.
- 3) Repeatedly actuate the tong motor control valve lever IN BOTH DIRECTIONS to dissipate any residual pressure in the valve and motor.
- 4) Remove the hydraulic SUPPLY line from the equipment.
- 5) Repeatedly actuate the remaining control valve levers IN BOTH DIRECTIONS to dissipate any residual pressure in the remainder of the hydraulic control system.
- 7) Disconnect the hydraulic RETURN line from the equipment.
- 8) Disconnect remaining hoses such as case drains, or lines connected to the turns counter.



**HYDRAULIC PRESSURES AS HIGH AS OPERATING PRESSURE MAY REMAIN TRAPPED IN SMALL AREAS OF THE EQUIPMENT. ENSURE ALL MAINTENANCE IS CARRIED OUT BY A QUALIFIED SERVICE TECHNICIAN, AND THAT ADEQUATE PERSONAL PROTECTIVE EQUIPMENT IS USED TO GUARD AGAINST PRESSURE INJURIES**

**3.E LUBRICATION INSTRUCTIONS**

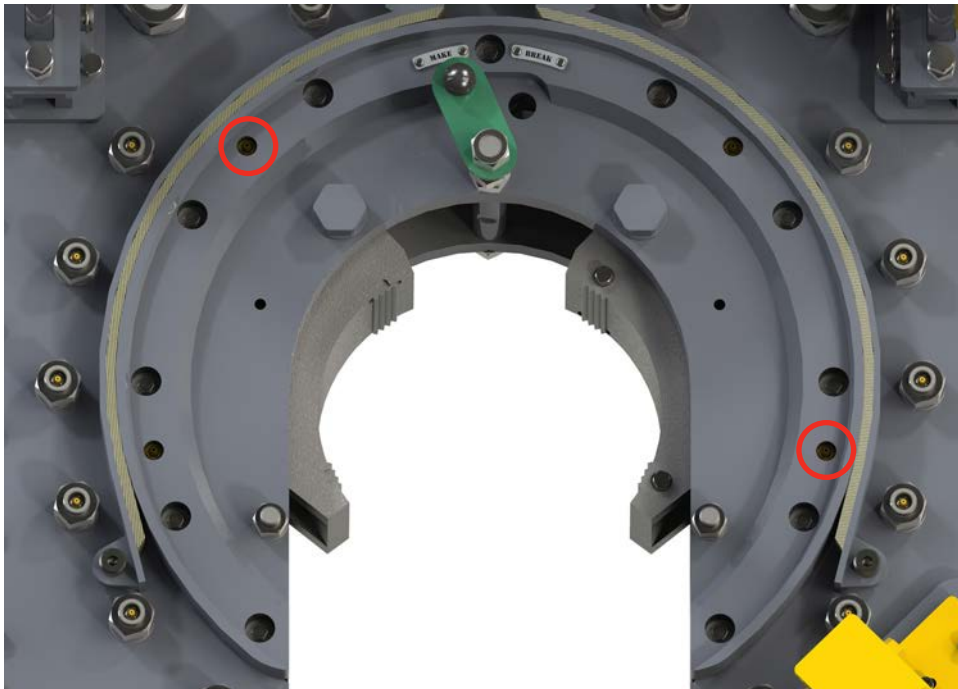
Use a quality multipurpose bearing lubricant that will remain within its viscosity range at expected operating temperatures. In addition, McCoy recommends the following lubrication procedure at the completion of each job prior to storage.

McCoy recommends that a liberal coating of grease be applied to the cam surface of the rotary drive gear prior to jaw installation. Also, the clutch inspection plate should periodically be removed, and a liberal coating of grease applied to the clutch, drive gears and shifting shaft.

Coat the jaw pins and rollers with a liberal amount of anti-seize compound when installing new jaw die kits.

**3.E.1 Cage Plate Guide Rings**

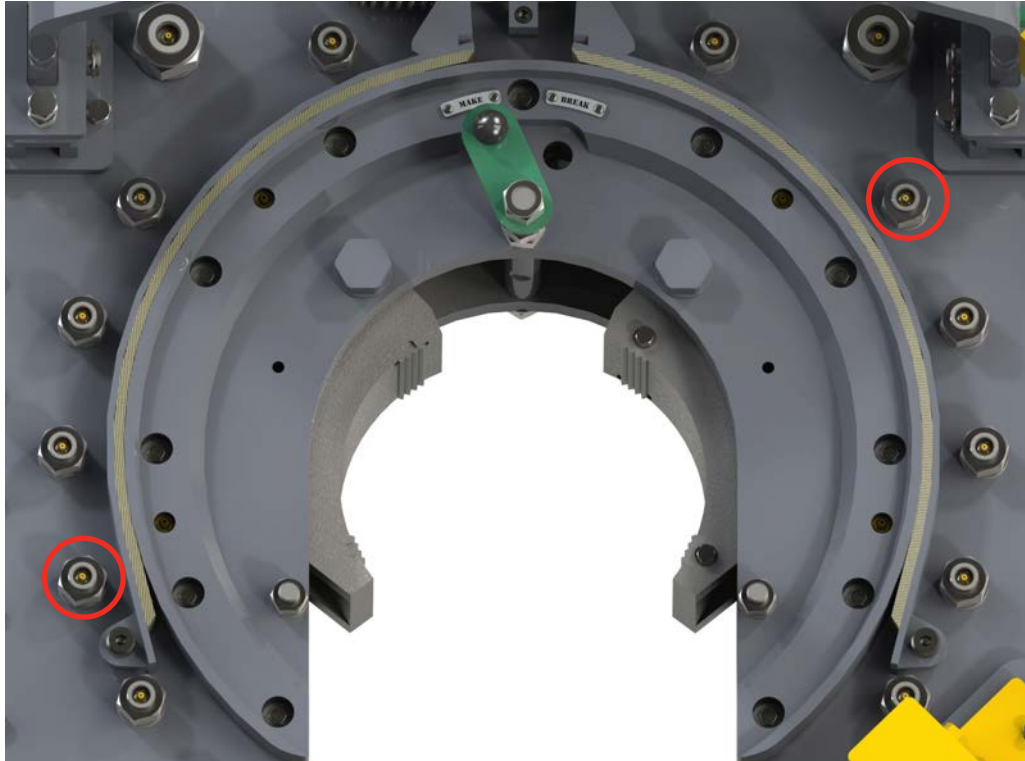
Lubricate the guide rings through the grease fittings on the top and bottom cage plates, four on top and four on the bottom (See Illustration 3.E.1).



**Illustration 3.E.1: Guide Ring Lubrication**

**3.E.2 Support Rollers**

Apply grease to the support roller bearings through the grease fittings recessed into the top of each support roller shaft (14 locations top, 14 locations bottom).



**Illustration 3.E.2: Support Roller Lubrication**

**3.E.3 Rotary Idlers**

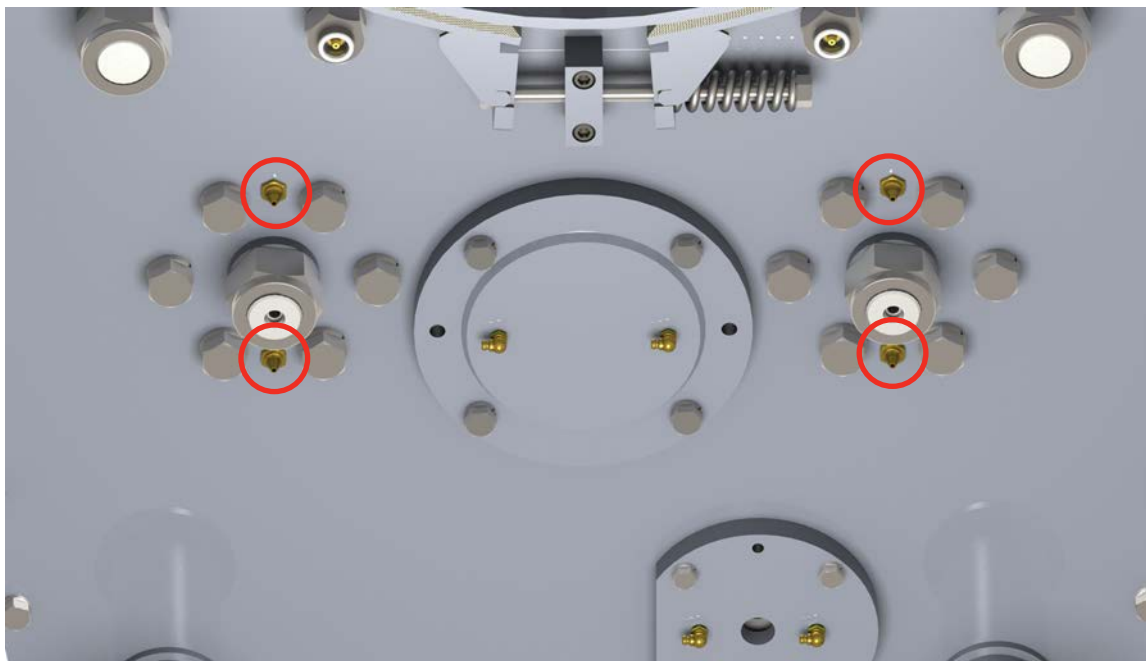
Apply grease to the rotary idler bearings through the grease fittings recessed into the top of each shaft on the top face of the tong (two locations total).



**Illustration 3.E.3: Rotary Idler Lubrication**

**3.E.4 Pinion Idlers**

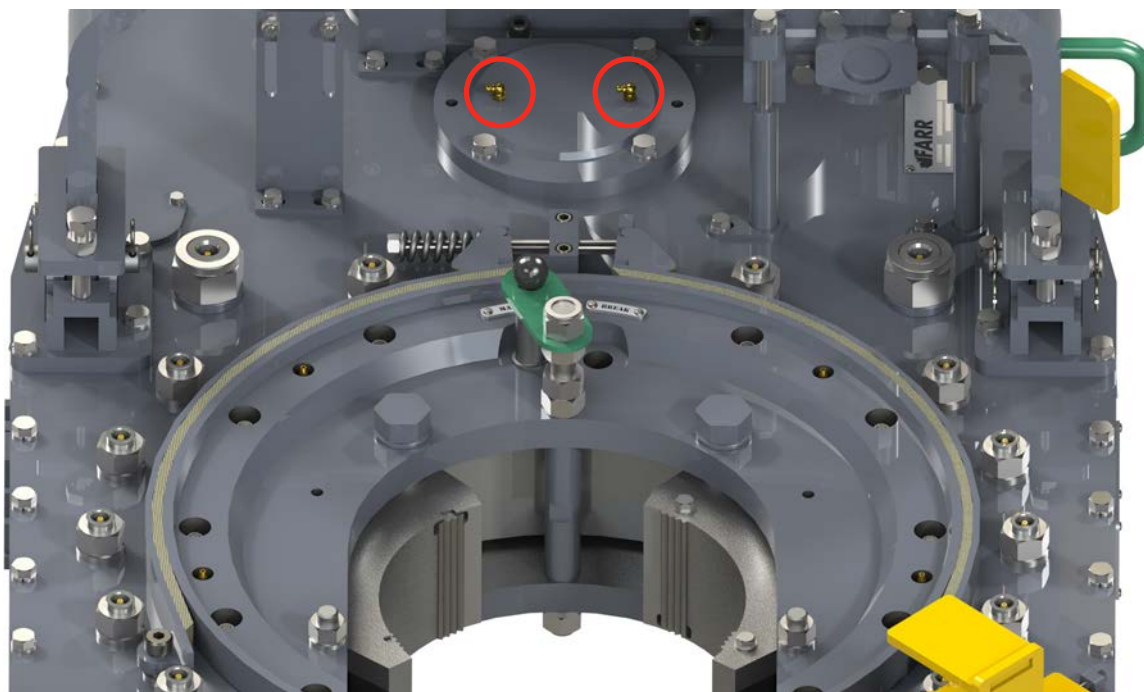
Apply grease to the pinion idler bearing through the grease fittings installed in the bottom plate on either side of the nylock nut securing each half-shaft, (four locations total).



**Illustration 3.E.4: Pinion Idler Lubrication**

**3.E.5 Pinion**

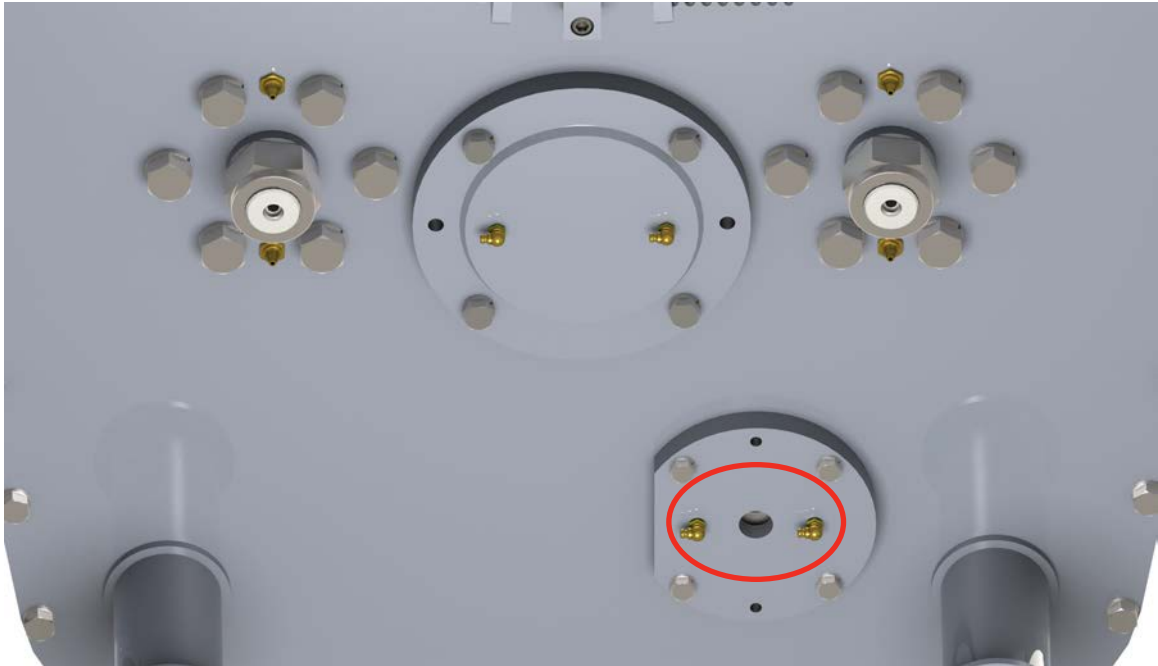
Apply grease to the pinion bearings through the grease fittings located on the bearing caps on the top and bottom faces of the tong (two locations top, two locations bottom).



**Illustration 3.E.5: Pinion Lubrication**

**3.E.6 Clutch**

Apply grease to the clutch bearings through the two grease fittings located on the clutch bearing cap on the bottom face of the tong, and the single grease fitting recessed into the end of the clutch shaft. (three locations total). NOTE: A protective plug may have been inserted into the end of the clutch shaft over the grease fitting prior to shipping - this plug may be removed for normal operation.



**Illustration 3.E.6: Clutch Lubrication**

**3.E.7 Motor Mount**

Apply grease to the motor gear/clutch drive gear through the grease fittings located on the top of the motor mount next to the lay gear bearing cap (two locations).

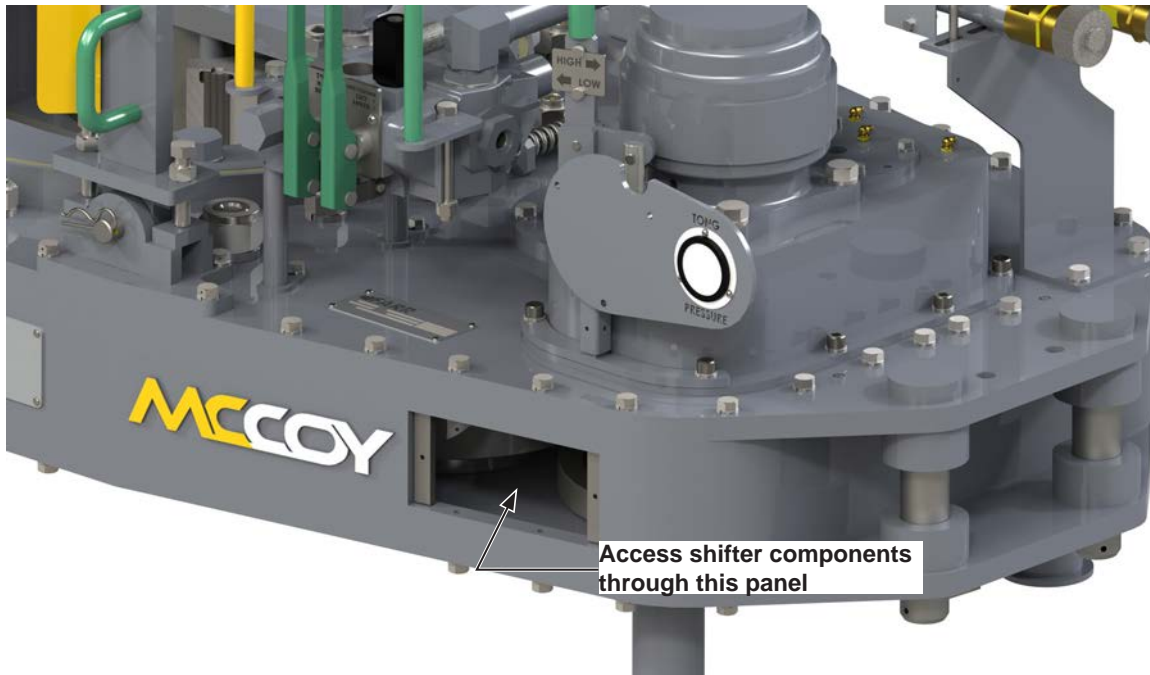


**Illustration 3.E.7: Motor Mount Lubrication**



**3.E.8 Shifting Shaft**

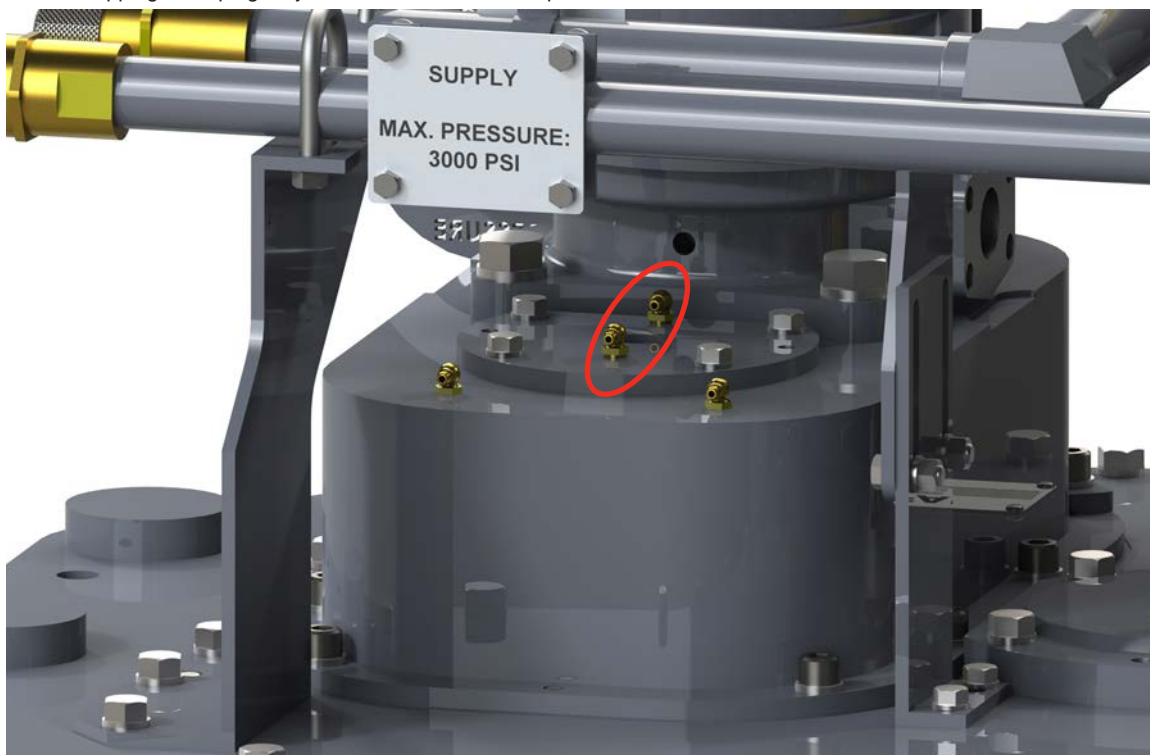
Apply grease to the shifting shaft and top shifting shaft bushing. The shaft and shifting yoke can be accessed through the cover plate on the side of the tong.



**Illustration 3.E.8: Shifter Component Lubrication**

**3.E.9 Lay Gear Assembly**

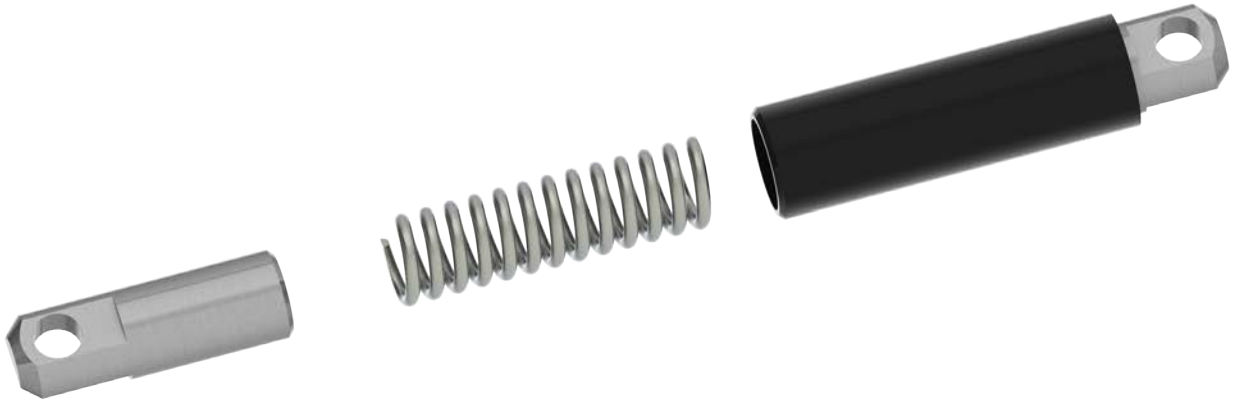
Apply grease to the door latch through the two grease fittings located in the bearing cap, and the one grease fitting in the end of the lay gear shaft. NOTE: A protective plug may have been insert-ed into the end of the lay shaft over the grease fitting prior to shipping - this plug may be removed for normal operation.



**Illustration 3.E.9: Lay Gear Lubrication**

**3.E.10 Door Spring Cylinder**

Periodically disassemble the door stop cylinders and coat the spring and cylinder with a general purpose lubricating oil.



**Illustration 3.E.10: Door Spring Cylinder (Exploded)**

**Recommended lubrication amount at the completion of each job:**

- |                                             |                 |
|---------------------------------------------|-----------------|
| 1. Cage Plate Guide Rings (Upper and lower) | 1 shot grease   |
| 2. Rotary Roller Bearings (Upper and lower) | 3 shots grease  |
| 3. Rotary Idler Bearings                    | 4 shots grease  |
| 4. Pinion Idler Bearings                    | 4 shots grease  |
| 5. Pinion Bearings (Upper and lower)        | 2 shots grease  |
| 6. Clutch Shaft Bearings                    | 1 shot grease   |
| 7. Motor Mount Housing                      | 10 shots grease |
| 8. Shifting Shaft                           | as required     |
| 9. Lay Gear                                 | 1 shot grease   |

McCoy recommends that a liberal coating of grease be applied to the cam surface of the rotary drive gear prior to jaw installation. Also, the clutch inspection plate should periodically be removed, and a liberal coating of grease applied to the clutch, drive gears and shifting shaft.

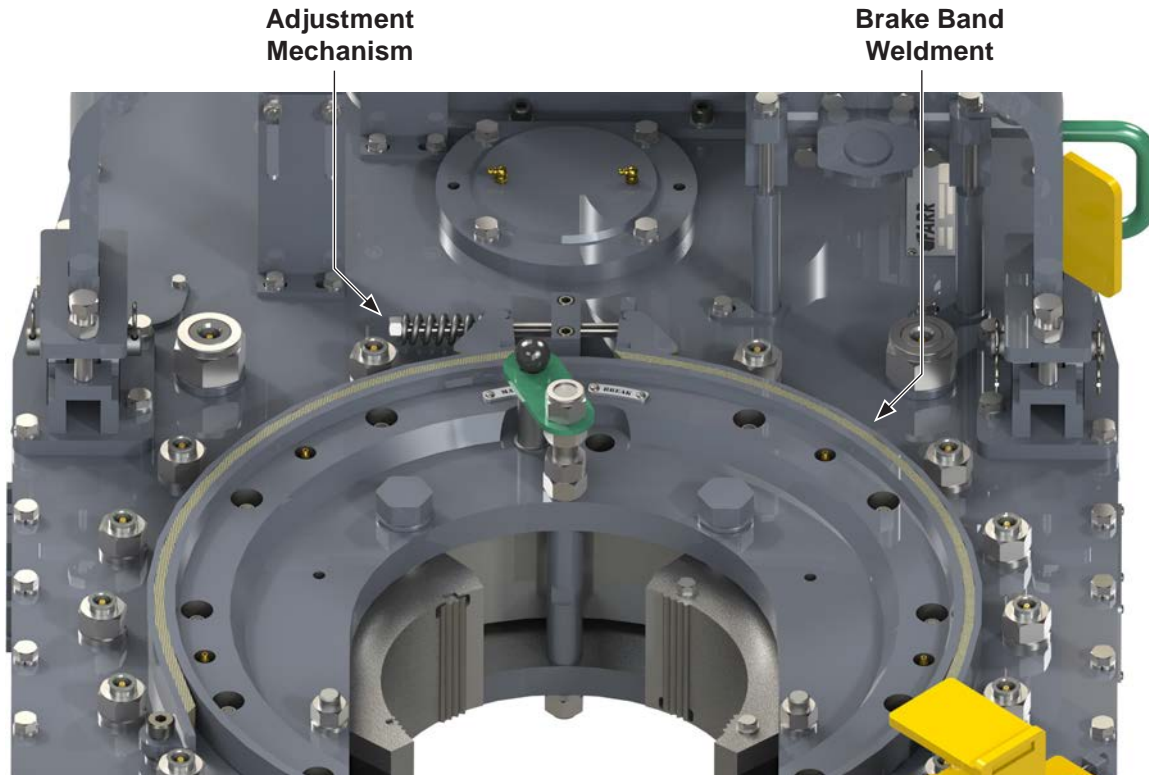
## 3.F ADJUSTMENTS

## 3.F.1 Brake Band Adjustment

The brake bands must be periodically adjusted to continue to provide smooth and efficient jaw cam action. Inadequate cage plate tension will allow the cage plate to rotate with the rotary gear, resulting in poor gripping of the pipe or casing due to improper “camming” action of the tong jaws. Tightening the brake band against the cage plates will increase frictional resistance, allowing jaws to cam properly and grip the casing. Adjust the brake band using the adjustment nut and bolt set as shown in the illustration below. Do not over-tighten, as this causes excessive wear to the brake bands. Ensure all four brake bands are adjusted simultaneously and equally.



**TOP AND BOTTOM BRAKE BANDS MUST BE ADJUSTED SIMULTANEOUSLY AND EQUALLY**



**Illustration 3.F.1: Brake Band Adjustment**



**3.F.2 Shifter Detent Force Adjustment:**

Over time wear to the shifting shaft, wear to the detent balls, and loss of spring tension in the detent springs may result in a loose or “sloppy” fit within the top shifter bushing. The detent pressure may be increased or otherwise adjusted by loosening the 7/16” UNF locking jam nuts, and threading in the 7/16” UNF detent bolts to increase the spring force. Should adequate detent action not be achieved, the shifting shaft, detent balls, or detent springs (or possibly all three) may need to be replaced (see Pp. 5.20 - 5.21). NOTE: When adjusting detent spring force, ensure both detent spring assemblies are adjusted simultaneously and equally. Additionally, if the decision is made to replace detent springs and balls, ensure both sets are replaced at the same time.



**Illustration 3.F.2: Shifter Detent Force Adjustment**

**3.G RECOMMENDED PERIODIC CHECKS****3.G.1 Door Stop Spring**

The springs inside the spring stop cylinders must be of sufficient strength to hold the doors in the open position when opened. Replace the spring inside the cylinder when the door stop cylinder is no longer of sufficient strength to hold the door open.

**3.G.2 Backing Pin**

Perform a visual inspection of the backing pin after each job. Replace the pin if stress cracks or excessive wear is found, or if the pin is bent.

**3.G.3 Shifting Shaft**

The shifting yoke is secured to the shifting shaft by one hex jam nut below the yoke. Check the nuts after each job. Do this by removing the clutch inspection plate and ensuring a snug fit prior to lubrication.

**3.G.4 Torque Gauge Assembly**

Periodic calibration of the torque gauge is recommended to assure accurate torque readings. When having the torque gauge serviced and calibrated, it is critical to note the arm length of the tong, as indicated in the “Specifications” section. McCoy recommends that the torque gauge assembly be calibrated yearly. Periodically check to ensure the load cell is filled with oil (see Section 6).

## 3.H REMOVAL OF TOP PLATE FOR OVERHAUL

The tong may be overhauled following the disassembly instructions in the following procedure. Access to the gear train is possible by removing the top plate of the tong.



**ALL MAINTENANCE AND OVERHAUL SHOULD BE PERFORMED FROM THE TOP. THE BOTTOM PLATE OF THE TONG IS TYPICALLY WELDED TO THE SIDE BODY AND CANNOT BE REMOVED.**



**REPLACEMENT FASTENERS (BOLTS, NUTS, CAP SCREWS, MACHINE SCREWS, ETC.) USED DURING MAINTENANCE OR OVERHAUL MUST BE GRADE 8 OR EQUIVALENT UNLESS OTHERWISE SPECIFIED.**

1. Ensure tong is well-supported from the bottom, using structure that will safely support the entire weight of the tong. A pair of heavy-duty metal horses works well in this application.
2. Use a crane to lift the tong by the master link, and place on work horses. Double-check the placement of the horses under the tong to ensure the tong is initially positioned for removing the door assemblies i.e. the front horse supports the tong just behind the front legs.
3. Remove the tong door spring cylinder.
4. Unscrew the rear door cylinder mounting post from the bottom plate and set aside.
5. Remove door assembly:
  - Disconnect the hydraulic connections from the safety door switch. Remove the safety door switch mounting plate and guard assembly - the safety door switch may remain mounted to the plate.
  - Remove the bottom safety door adjustment plate weldment from the top plate - the safety door adjustment screw may remain in place.
  - Open the tong door. Remove the nylock nuts from the top and bottom of the latch post, then remove the top and bottom door latch bushings.
  - Remove the door latch post. Use of a rubber mallet may be required to tap the post through the plates.
  - Support the tong door using a crane. Remove the nylock nut from the bottom of the door pivot pin - leave the top nut in place. Pull the pivot pin straight up out of the door and tong body.
  - Set the door assembly aside in a convenient location.
6. Use a crane to hoist the tong off the horses. Reposition the front horse so it supports the tong across the tong opening approximately where the door latch and pivot posts were installed.
7. Support the rigid sling with a crane; extract one hitch pin from each rigid sling pin, and pull each rigid sling pin to separate the rigid sling weldment from the rigid sling brackets.
8. If not already done remove jaw assemblies.
9. Disconnect the hydraulic connections to the motor. Contain hydraulic fluid spilled from disconnected lines and dispose in accordance with your company's environmental policies.
10. Undo the restraints securing the inlet and outlet lines connections to their supports. Remove the long bolts securing the valve assembly to the valve mount weldments (two locations), and use a crane to lift the hydraulic valve section away from the tong.
11. Remove the valve assembly mounting posts, inlet support, and outlet support from the top plate.
12. Completely loosen the bottom brake bands, and remove top brake band assemblies.
13. Extract the hitch pin securing the torque gauge/pressure gauge mount to the mounting base weldment, and remove the gauge mount. Remove the torque gauge mounting base weldment from the left side of the motor mount flange.
14. Remove the clevis pins securing the shifter handle weldment to the shifter shaft and lug weldment, and remove handle.
15. Remove the four hex head cap screws securing the motor to the motor mount, then lift the motor up and away from the motor mount. Inspect the motor gear, located at the bottom of the motor shaft, for gear clashing or tooth damage. Also, ensure that the motor gear is securely attached to the motor shaft.
16. Remove the four bolts securing the lay gear bearing cap, and pull the bearing cap straight up.



**IF THE BEARING REMAINS ATTACHED TO THE LAY GEAR SHAFT AFTER THE BEARING CAP IS PULLED, MCCOY GLOBAL SERVICE DEPARTMENT RECOMMENDS LEAVING IT IN PLACE UNTIL THE TOP TONG PLATE IS REMOVED.**

**3.H REMOVAL OF TOP PLATE FOR OVERHAUL (CONTINUED):**

17. Back off the two shifter detent bolts until neither of the springs are placing any force on the shifter shaft.
18. Remove the access panel from the left rear side. Remove the nut securing the shifting shaft to the shifting fork. Remove the shifting shaft by rotating and pulling up through the shifting shaft bushings and the shifting fork.
19. Remove the remaining six hex socket head cap screws securing the motor mount to the top plate. Use care not to dislodge and lose the two positioning dowels as the motor mount is lifted away from the top plate.
20. Pull the lay gear stack straight up and out of the lower lay gear bearing, which may remain pressed into the top plate. Ensure the bottom spacer remains with the gear stack.
21. Remove the clutch shaft plate and the 1/2" flat head machine screw securing the clutch drive gear to the top of the clutch shaft. Carefully remove the drive gear from the clutch shaft. Do not lose the drive gear key.
22. Remove the four 3/8" hex flat head cap screws securing the top clutch bearing plate to the top plate. Remove the top clutch bearing plate and the top clutch shaft spacer, and bearing retainer spacer.
23. Pull the top pinion gear bearing cap by removing the four 1/2" bolts which secure the bearing cap. Thread two of the removed bolts into the extra holes on top of the bearing cap, and use them to press the bearing cap out of place.



**IF THE BEARING REMAINS ATTACHED TO THE PINION GEAR SHAFT AFTER THE BEARING CAP IS PULLED, MCCOY GLOBAL SERVICE DEPARTMENT RECOMMENDS LEAVING IT IN PLACE UNTIL THE TOP TONG PLATE IS REMOVED.**

24. Remove the backing pin knob and the nylock nut securing the backing pin retainer to the rear cage plate bolt. Remove the two 7/8" hex nuts from the rear cage plate bolt, but leave the nut securing the rear cage plate bolt to the top cage plate in place.



**THE CAGE PLATE BOLTS ARE THE ONLY ITEMS FASTENING THE BOTTOM CAGE PLATE TO THE TONG. SUPPORT THE BOTTOM CAGE PLATE FROM BELOW PRIOR TO REMOVING CAGE PLATE BOLTS IN ORDER TO PREVENT DAMAGE TO THE BOTTOM CAGE PLATE OR PERSONAL INJURY TO THE MECHANIC**

25. Ensure the bottom cage plate is supported. Remove the top nuts from the two front cage plate spacers and the rear cage plate bolt. Lift the top cage plate straight up and off the cage plate bolts. Do not damage the manganese bronze guide rings, which are mounted to the cage plates.
26. Remove the bottom cage plate with the spacers and rear cage plate bolt still attached.
27. Remove the left and right rigid sling brackets.
28. Remove the top nuts and pads for the rotary idler gears.
29. Remove the hex head bolts and hex socket head cap screws around the perimeter of the tong that secure the top plate weldment to the side body.
30. With all the above steps taken, the top tong plate weldment can be lifted off providing access to the inside of the gear case. The support roller half-shafts may remain attached to the top plate.



**LIFT THE TOP PLATE STRAIGHT UP TO AVOID SNAPPING THE DOWEL PINS. A SNAPPED OR OTHERWISE DAMAGED DOWEL PIN CAN BE EXTREMELY DIFFICULT TO REMOVE**

3.1 ASSEMBLY PROCEDURES

Although the assembly of McCoy hydraulic power tongs is straightforward, and can be accomplished without the use of special tools, the instructions in this subsection are presented as a guide only and are similar to the assembly sequence our technician would use while assembling the tong in our plant.

**NOTE ON INSTALLATION PRACTICES:** Ensure all bearings are liberally greased before installing over a shaft or into gears or bearing caps. When inserting a shaft through a support roller assembly ensure shaft is greased. Also ensure all metal-to-metal contact in the gear train is adequately greased. **When graphics are not used in the assembly process, please refer to the relevant exploded diagrams in Section 5.**



**ALL FASTENERS USED DURING REASSEMBLY OF LOAD-BEARING COMPONENTS (CHAIN SLINGS, RIGID SLINGS, BACKUP LEGS) MUST BE TIGHTENED TO THE CORRECT TORQUE. THREADED FASTENERS USED IN LOAD-BEARING DEVICES MUST BE SECURED WITH RED LOCTITE™.**

TIGHTENING TORQUE GUIDE			
SAE GRADE 8 - FINE THREAD			
SIZE	CLAMP LOAD	PLAIN	PLATED
¼ - 28 (.250)	3,263	14 ft. lbs.	10 ft. lbs.
5/16 - 24 (.3125)	5,113	27 ft. lbs.	20 ft. lbs.
3/8 - 24 (.375)	7,875	49 ft. lbs.	37 ft. lbs.
7/16 - 20 (.4375)	10,650	78 ft. lbs.	58 ft. lbs.
½ - 20 (.500)	14,400	120 ft. lbs.	90 ft. lbs.
9/16 - 18 (.5625)	18,300	172 ft. lbs.	129 ft. lbs.
5/8 - 18 (.625)	23,025	240 ft. lbs.	180 ft. lbs.
¾ - 16 (.750)	33,600	420 ft. lbs.	315 ft. lbs.
7/8 - 14 (.875)	45,825	668 ft. lbs.	501 ft. lbs.
1 - 12 (1.000)	59,700	995 ft. lbs.	746 ft. lbs.
1 - 14 (1.000)	61,125	1019 ft. lbs.	764 ft. lbs.
1-1/8 - 12 (1.125)	77,025	1444 ft. lbs.	1083 ft. lbs.
1-1/4 - 12 (1.125)	96,600	2012 ft. lbs.	1509 ft. lbs.
1-3/8 - 12 (1.375)	118,350	2712 ft. lbs.	2034 ft. lbs.
1-1/2 - 12 (1.500)	142,275	3557 ft. lbs.	2668 ft. lbs.
SAE GRADE 8 - COARSE THREAD			
SIZE	CLAMP LOAD	PLAIN	PLATED
¼ - 20 (.250)	2,850	12 ft. lbs.	9 ft. lbs.
5/16 - 18 (.3125)	4,725	25 ft. lbs.	18 ft. lbs.
3/8 - 16 (.375)	6,975	44 ft. lbs.	33 ft. lbs.
7/16 - 14 (.4375)	9,600	70 ft. lbs.	52 ft. lbs.
½ - 13 (.500)	12,750	106 ft. lbs.	80 ft. lbs.
9/16 - 12 (.5625)	16,350	153 ft. lbs.	115 ft. lbs.
5/8 - 11 (.625)	20,325	212 ft. lbs.	159 ft. lbs.
¾ - 10 (.750)	30,075	376 ft. lbs.	282 ft. lbs.
7/8 - 9 (.875)	41,550	606 ft. lbs.	454 ft. lbs.
1 - 8 (1.000)	54,525	909 ft. lbs.	682 ft. lbs.
1-1/8 - 7 (1.125)	68,700	1288 ft. lbs.	966 ft. lbs.
1-1/4 - 7 (1.125)	87,225	1817 ft. lbs.	1363 ft. lbs.
1-3/8 - 6 (1.375)	103,950	2382 ft. lbs.	1787 ft. lbs.
1-1/2 - 6 (1.500)	126,450	3161 ft. lbs.	2371 ft. lbs.



**REPLACEMENT FASTENER (BOLTS, NUTS, CAP SCREWS, MACHINE SCREWS, ETC.) USED DURING MAINTENANCE OR OVERHAUL MUST BE GRADE 8 OR EQUIVALENT UNLESS OTHERWISE SPECIFIED.**

3.1 ASSEMBLY PROCEDURES (CONTINUED):



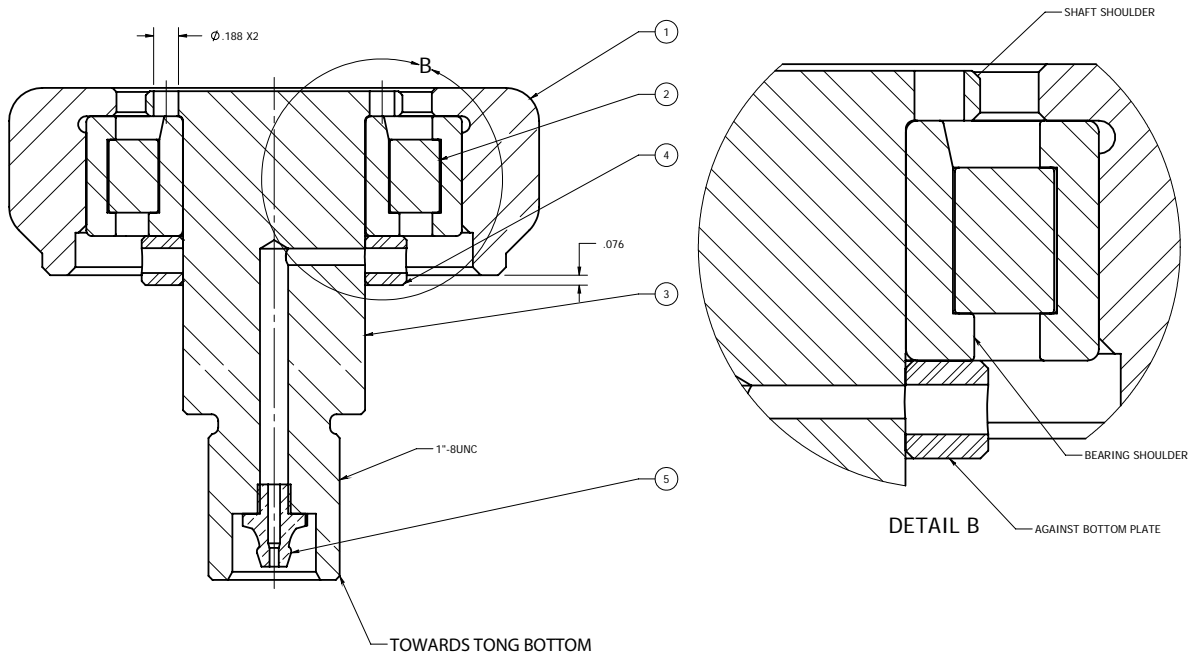
**IMPORTANT ASSEMBLY INFORMATION**

**DO NOT TORQUE NYLOCK NUTS. NYLOCK NUTS ARE NOT USED FOR CLAMPING PURPOSES AND SHOULD ONLY BE TIGHTENED UNTIL METAL-TO-METAL CONTACT IS MADE AND VERTICAL MOTION IS ELIMINATED. OVERTIGHTENING WILL RESULT IN PREMATURE BUSHING FAILURE AND WILL INHIBIT ROTATION, AND MAY IMPART EXCESS STRESS ON ROTATING COMPONENTS.**

**APPLY A THIN LAYER OF GREASE TO THE SURFACE OF EACH MOVING PART DURING ASSEMBLY TO AID IN THE ASSEMBLY PROCESS.**

1. Arrange a support structure that will support the complete weight of the tong (weight = 3200 lbs / 1455 kg). A pair of sturdy metal horses works well for this application.
2. Use a crane to position the tong body weldment (weight = 643 lbs / 292 kg) upside-down on the metal horses. Ensure the weldment is squarely positioned on the horses before applying full weight.
3. Install bottom pinion bearing cap (PN 1393-89A) into bottom plate of tong. Secure with four 1/2" UNC x 1-1/2" hex bolts and 1/2" lock washers.
4. Install lower clutch bearing cap (PN 1393-54) into bottom plate of tong. Secure with four 3/8" UNC x 1-3/4" hex bolts and 3/8" lock washers.
5. Use a crane to hoist the tong body weldment, and rotate so that the inside of the bottom plate faces up i.e. the tong body is now oriented topside-up. Ensure the horses are properly positioned to support the tong before applying full weight.
6. Assemble 14 lower support roller assemblies (see assembly drawing 3.1.1) for installation in the bottom plate:
  - a. Press a support roller bearing (PN 02-E0258) into each of the bottom support roller cups (PN 101-6199) (14 total) See Detail D in assembly drawing for correct bearing installation. **ASSEMBLY NOTE:** The top support roller cups are machined on the inside for a snap ring while the bottom support roller cups are not. Do not mix the top and bottom support roller cups, which are unique for their applications.
  - b. Insert a support roller half-shaft (PN 101-6193) through the bottom of each of the 14 roller cup assemblies.
  - c. Slide a bottom rotary support spacer (PN 101-6206) over the top of each of the 14 support roller half-shafts until the spacer makes contact with the bearing shoulder.

ITEM	QTY	P/N	TITLE	SUBJECT	DESCRIPTION
1	1	101-6199	ROLLER	ROTARY SUPPORT- BOTTOM	KT14-75K
2	1	02-E0258	BEARING	CYLINDRICAL ROLLER	NJ2207E
3	1	101-6193	SHAFT	ROTARY SUPPORT ROLLER	KT14-75K
4	1	101-6206	SPACER	BOTTOM ROTARY SUPPORT	KT 14-75K
5	1	02-0070	FITTING	STRAIGHT GREASE	1/4 NF SHORT



**Illustration 3.1.1: Bottom Support Roller Assembly Drawing**

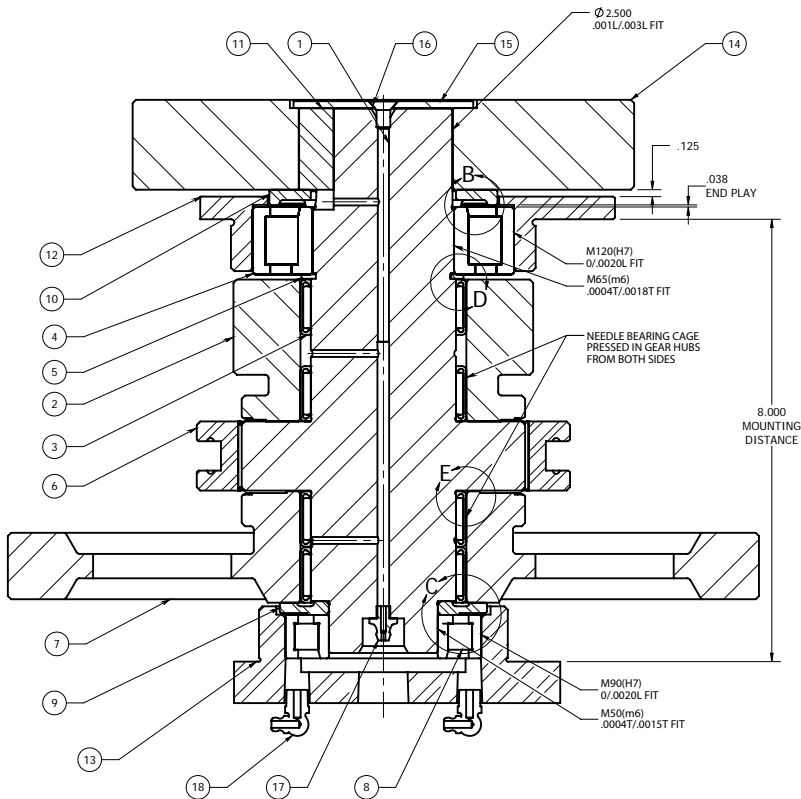
3.1 ASSEMBLY PROCEDURES (CONTINUED):

- 7. Install fourteen support roller assemblies around the tong opening in the bottom plate, and secure each with a 1" UNC hex nut and 1" lock washer (see illustration 3.1.2).

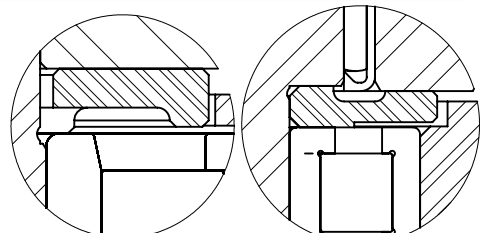


Illustration 3.1.2: Bottom Support Roller Installation

- 8. Thread two 1/2" UNC eye bolts in to the threaded holes located within the top guide ring slot on the rotary gear (PN 101-6204). Use a temporary sling and crane to move the rotary gear (weight = 347 lbs /158 kg) and place on to the bottom support rollers.
- 9. Refer to clutch assembly drawing 3.1.3 for steps 9 through 16. Press two needle bearings (PN 1393-53) into the high clutch gear (PN 101-5922). Ensure the outer race of the bearings are flush with the inner shoulders of the gear.



ITEM	QTY	P/N	TITLE	SUBJECT	DESCRIPTION
1	1	101-5920	SHAFT	CLUTCH	CA-14-75K
2	1	101-5921	PINION	REDUCTION 3 LOW SPEED	CA-14-75K
3	4	1393-53	BEARING	NEEDLE	CLUTCH GEAR (B-4216)
4	1	02-E0257	BEARING	CYLINDRICAL ROLLER	NJ2213
5	1	02-E0237	SNAP RING	DIN471	EXTERNAL 65MM
6	1	1393-62	COLLAR	SHIFTING	SPLINE 8/16-30-40
7	1	101-5922	GEAR	REDUCTION 3-HS	CA-14-75K
8	1	1393-55	Bearing	SPHERICAL ROLLER	NJ210
9	1	101-5923	SPACER	1.980X3.750X0.250	CA-14-75K
10	1	101-5949	SPACER	CLUTCH SHAFT	CA-14-75K
11	1	101-5924	KEY	SQUARE (.625X.625X1.47)	CA-14-75K
12	1	101-5925	CAP	BEARING 22213	CA-14-75K
13	1	1393-54	CAP	CLUTCH BEARING	BOTTOM
14	1	101-5950	GEAR	REDUCTION 2	CA-14-75K
15	1	1393-50-04	PLATE	CLUTCH SHAFT	RETAINING
16	1	09-4003	SOCKET COUNTER SUNK HEAD	CAP SCREW	1/4"-.20 UNC -1/2"
17	1	02-0070	FITTING	STRAIGHT GREASE	1/4 NF SHORT
18	2	02-0093	FITTING	GREASE	1/8 NPT X 90 deg.



DETAIL B

DETAIL C

DETAIL D

DETAIL E

Illustration 3.1.3: Clutch Assembly Drawing



3.1 ASSEMBLY PROCEDURES (CONTINUED):

10. Press two needle bearings (PN 1393-53) into the low clutch gear (PN 101-5921). Ensure the outer race of the bearings are flush with the inner shoulders of the gear.
11. Invert the clutch gear shaft (PN 101-5920) so that the bottom of the clutch shaft faces up. **ASSEMBLY NOTE:** The “bottom” end of the clutch shaft has a recessed threaded port for a grease fitting. Slide the high clutch gear over the clutch gear shaft, with the gear oriented so that the smaller diameter portion of the gear presses against the center gear on the clutch shaft.
12. Slide the bottom clutch bearing spacer (101-5923) over the end of the clutch shaft, with the circular groove oriented toward the high clutch gear (see cross-section illustration 3.1.2).
13. Press the inner race of the lower clutch bearing (1393-55) on to the end of the clutch gear shaft with the shoulder of the race pressed against the clutch bearing spacer installed in the previous step. If necessary use a flat block and a mallet to evenly tap the race on to the shaft until the race is even with the clutch gear shaft.
14. Slide the low clutch gear over the top of the clutch gear shaft with the gear oriented so that the smaller diameter portion of the gear presses against the center gear on the clutch shaft. Secure the low clutch gear in place with an external retaining ring (PN 02-E0237).
15. Install the inner race of the upper clutch bearing (02-E0257) on to the top end of the clutch gear shaft. If necessary use a flat block and a mallet to evenly tap the race on to the shaft until the top of the race is even with the clutch gear shaft, then use a cylinder and mallet to lightly tap the race along the shaft until it comes in to contact with the retaining ring installed in the previous step.
16. Drop the remaining components of the lower clutch bearing (the inner race was installed in step 13) in to the clutch bearing cap.
17. Rotate the clutch assembly, and insert the inner race and clutch shaft in to the lower clutch bearing.
18. Install shifting collar (PN 1393-62) over the top of the clutch shaft and mesh with the centre clutch gear.
19. Press the high pinion gear (PN 101-5928) over the bottom of the splined pinion gear shaft (PN 101-5926). **ASSEMBLY NOTE:** Maximum assembly force is 19.6-25.2 tons. See pinion assembly drawing 3.1.4.

ITEM	QTY	P/N	TITLE	SUBJECT	DESCRIPTION
1	1	101-5926	PINION	REDUCTION 4	PA-14-75K
2	1	101-5927	GEAR	REDUCTION 3 LS	PA-14-75K
3	1	101-5928	PINION	REDUCTION 3 HS	PA-14-75K
4	1	101-5929	SPACER	PA-14-75K	KT14-75K
5	2	1393-93	BEARING	NJ 2214 EC	CYLINDRICAL ROLLER
6	1	101-6876	CAP	PINION BEARING	TOP
7	1	1393-89A	CAP	PINION BEARING	BOTTOM
8	4	02-0093	FITTING	GREASE	1/8 NPT X 90 deg.

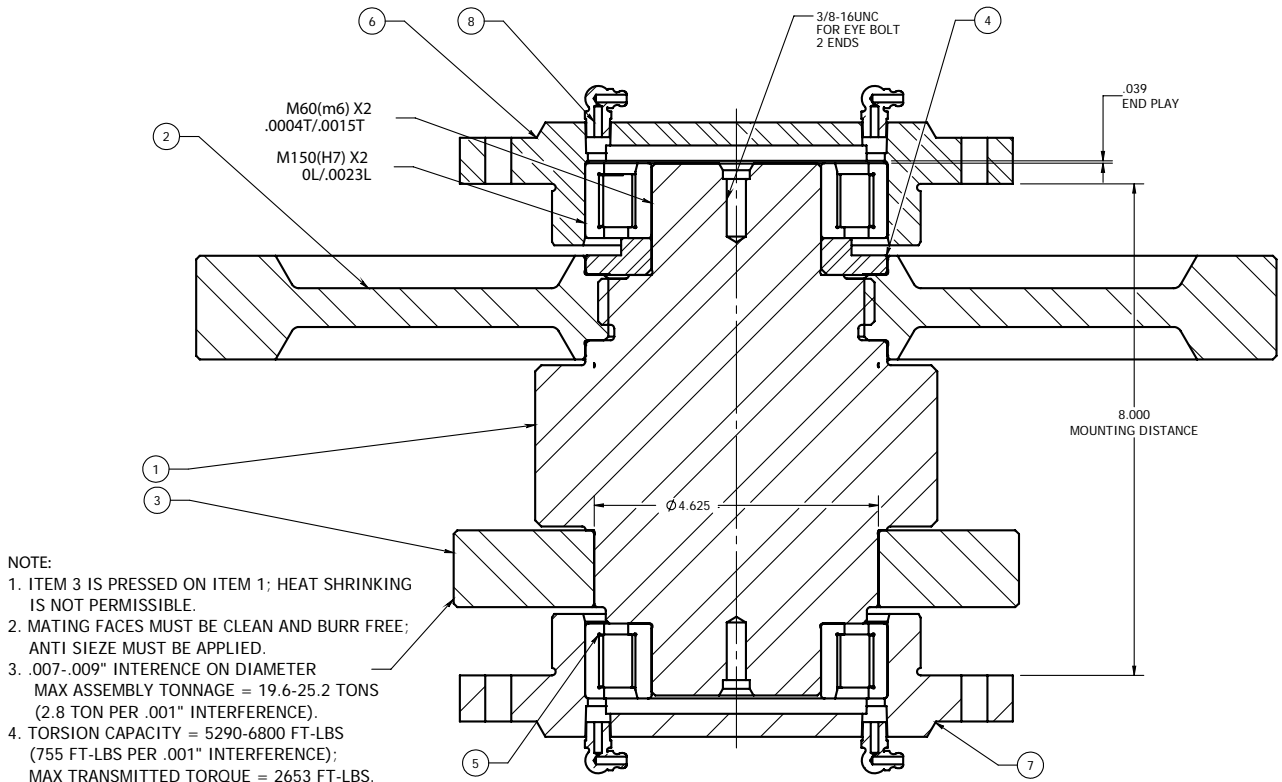
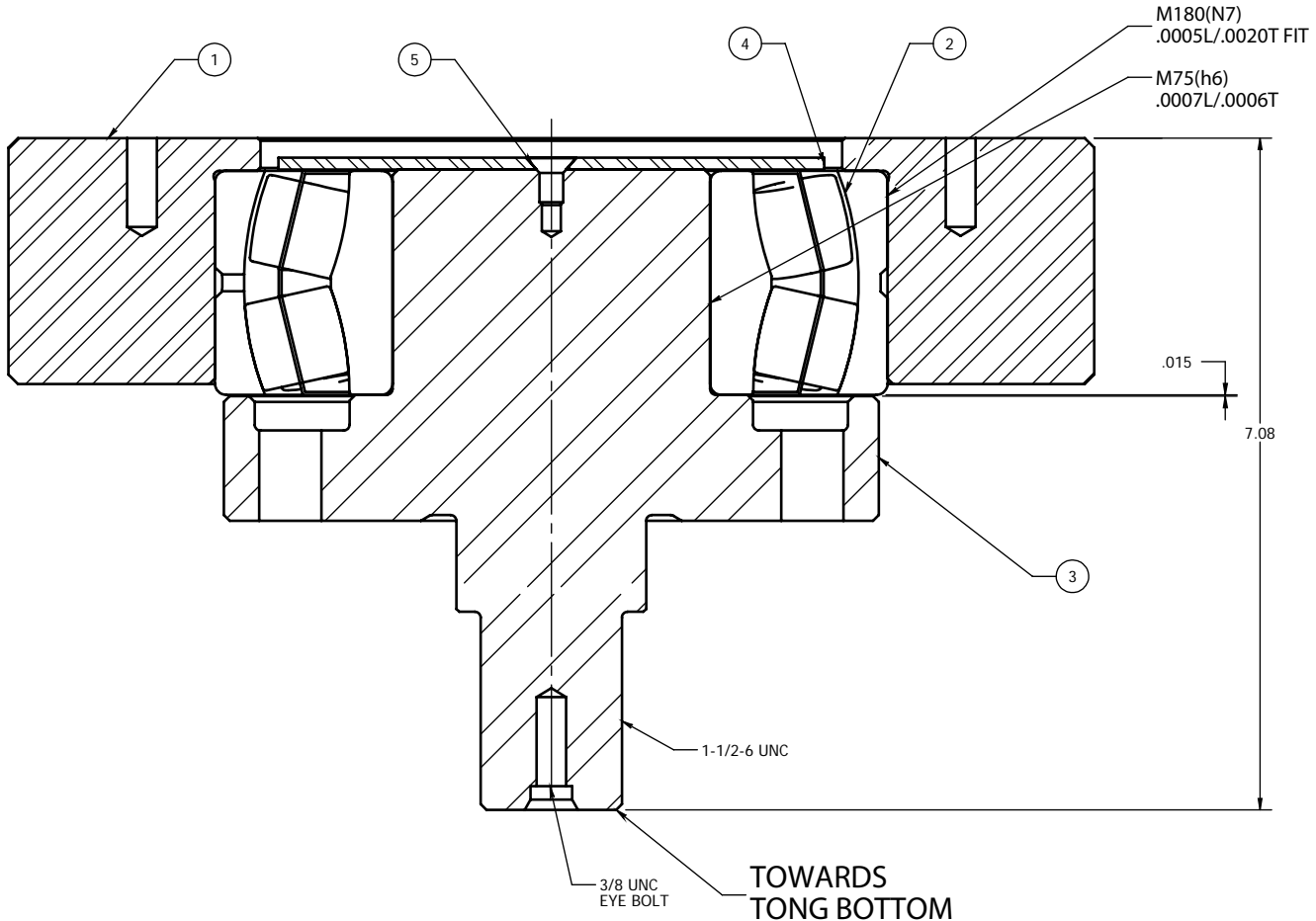


Illustration 3.1.4: Pinion Assembly Drawing

3.1 ASSEMBLY PROCEDURES (CONTINUED):

20. Press the inner race of the lower pinion bearing (PN 1393-93) on to the end of the pinion gear shaft oriented so the shoulder on the race is pressed against the shoulder on the gear shaft.
21. Drop the remaining components of the lower pinion bearing in to the pinion bearing cap.
22. Insert the inner race and pinion shaft in to the lower pinion bearing
23. Press a pinion idler bearing (PN 02-E0240) in to each pinion idler gear (PN 101-5930). See pinion idler assembly drawing 3.1.5.

ITEM	QTY	P/N	TITLE	SUBJECT	DESCRIPTION
1	1	101-5930	IDLER	32 TEETH	PIA-14-75K
2	1	02-E0240	BEARING	22317 CC/W33	SPHERICAL ROLLER
3	1	101-5931	SHAFT	PIA-14-75K	KT14-75K
4	1	101-5932	PLATE	RETAINING	PIA14-75K
5	1	09-4003	SOCKET COUNTERSUNK HEAD	CAP SCREW	1/4"-20 UNC -1/2"



**Illustration 3.1.5: Pinion Idler Assembly Drawing**

24. Insert a pinion idler half-shaft (PN 101-5931) in to each pinion idler gear assembly, and secure in place with a retaining plate (PN 101-5932) and a 1/4" UNC x 1/2" hex socket flat head countersunk machine screw. **ASSEMBLY NOTE:** The half-shaft is inserted from the same direction as the bearing. See Pp. 5.12 - 5.13 for proper orientation of the gear and half-shaft for assembly.
25. Insert both pinion idler assemblies through the bottom plate. Mesh the pinion idler gears with the pinion gear shaft. Secure the pinion idler half-shafts to the bottom plate using six 3/4" UNC x 1-3/4" hex bolts and 3/4" lock washers.
26. Place the shifting fork (PN 101-6010) roughly in its final position, meshed with the shifting collar.
27. Thread a 5/16" UNC eye bolt in to each of the threaded holes in the low pinion gear (PN 101-5927).
28. Use a temporary lifting sling and a crane to hoist the low pinion gear (weight = 60 lbs /27.3 kg) and install over the splines of the pinion gear shaft, meshing with the low clutch gear. Slide the pinion gear spacer (PN 101-5929) over the top end of the pinion gear, oriented so the shoulder on the spacer faces upward, and nest in the low pinion gear.

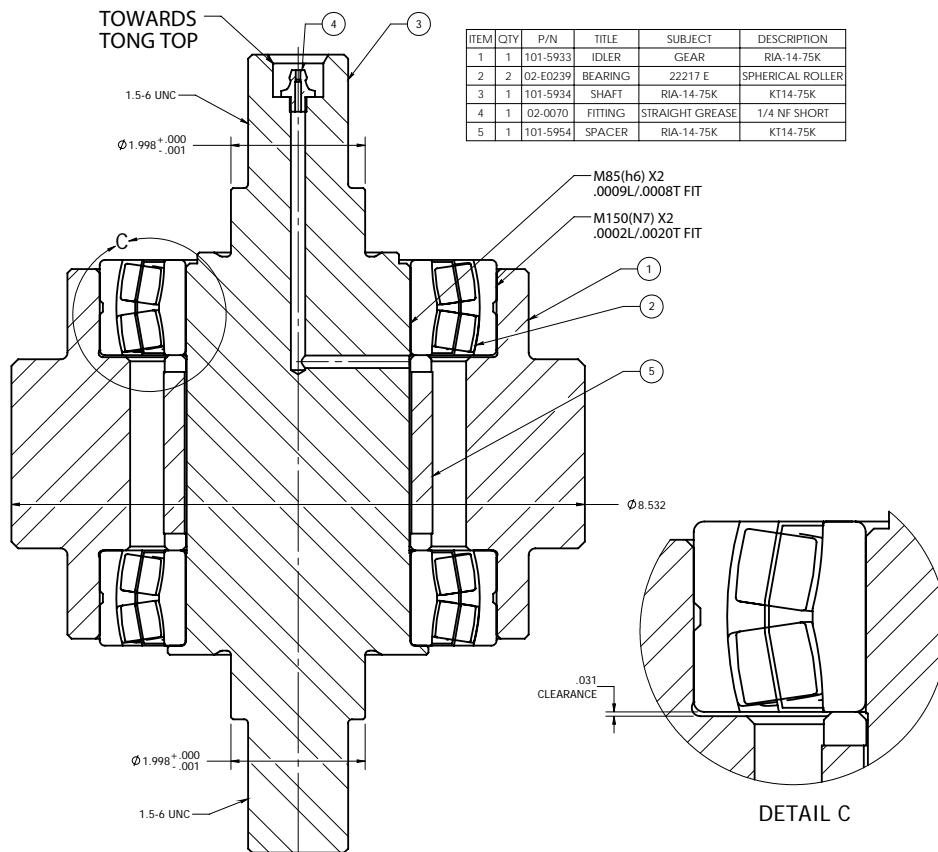
3.1 ASSEMBLY PROCEDURES (CONTINUED):

29. Remove the inner race from the top pinion bearing (PN 1393-93). Install on to the top end of the pinion gear shaft, with the shoulder on the race is oriented toward the gear. Use a flat block and a mallet to evenly tap the race on to the shaft until the shoulder of the race comes in to contact with the pinion gear spacer.



**Illustration 3.1.6: Pinion Bearing Inner Race Installation**

30. Press a rotary idler bearing (PN 02-E0239) in to one side of each rotary idler gear (PN 101-5933) until the bearing comes in to contact with the inner shoulder. See rotary idler assembly drawing in illustration 3.1.7.



**Illustration 3.1.6: Rotary Idler Assembly Drawing**

3.1 ASSEMBLY PROCEDURES (CONTINUED):

31. Insert an inner idler spacer (PN 101-5954) in to each rotary idler gear, and press the second idler bearing into the other end of each rotary idler gear.
32. Insert a rotary idler shaft (PN 101-5934) in to each rotary idler assembly. Centre the assemblies on the shafts. Slide a bearing spacer over the bottom end of each rotary idler shaft. **ASSEMBLY NOTE:** The ends of the idler shafts threaded for grease fittings are the tops of the shafts.
33. Insert the two rotary idler assemblies into the bottom plate and mesh with the rotary gear. Place an idler pad (PN 101-6029) over the bottom of each shaft, followed by a 1-1/2" hex nylock nut.
34. Assemble 14 upper support roller assemblies (see illustration 3.1.8 for and assembly drawing of the top support roller assemblies) for installation in the top plate:
  - a. Press a support roller bearing (PN 02-E0258) into each of the top support roller cups (PN 101-6200) (14 total).
  - b. Secure the bearing in the roller cup using an inside snap ring (PN 02-E0259).
  - c. Insert a support roller half-shaft (PN 101-6193) through the bottom of each of the 14 roller cup assemblies.
  - d. Slide a top support spacer (PN 101-6207) over the top of each of the 14 support roller half-shafts. **ASSEMBLY NOTE:** Ensure the flat side of the spacer is oriented toward the top of the shaft and the machined side is oriented toward the roller cup.

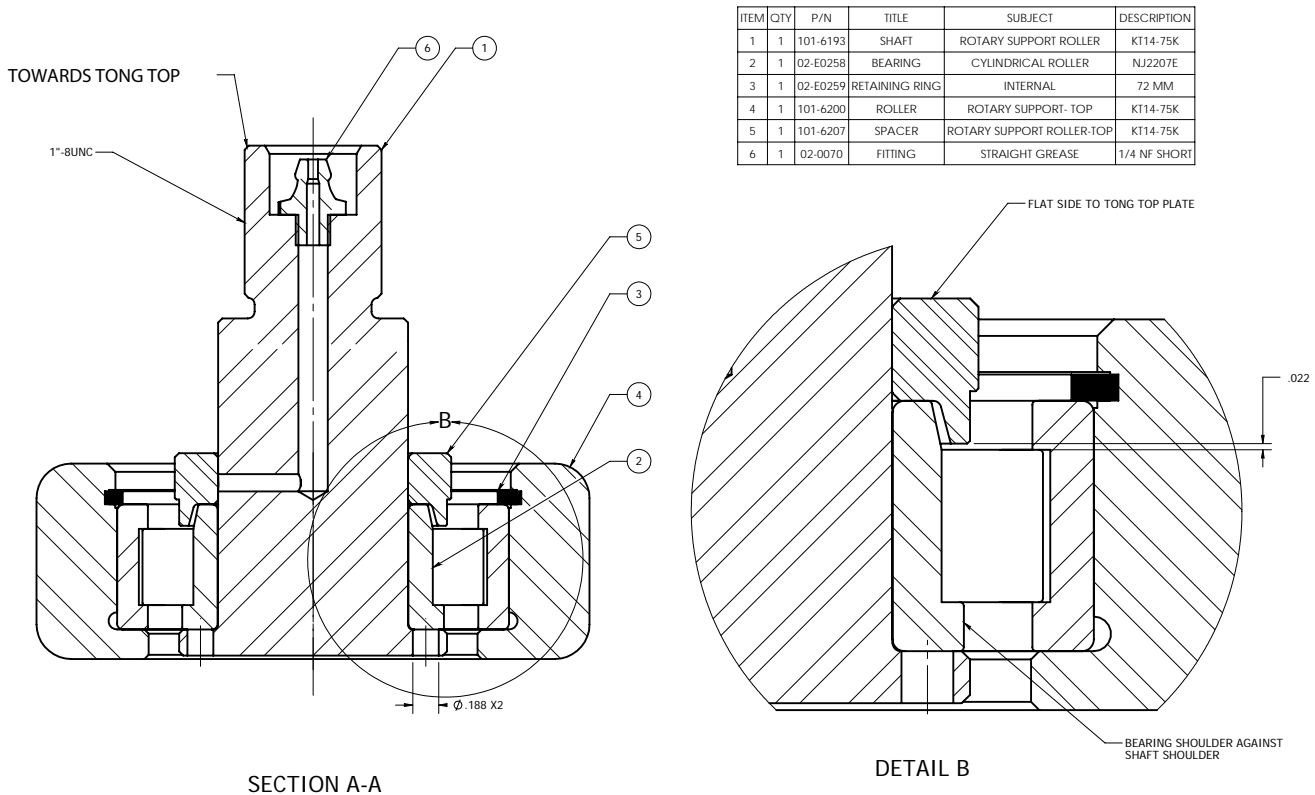
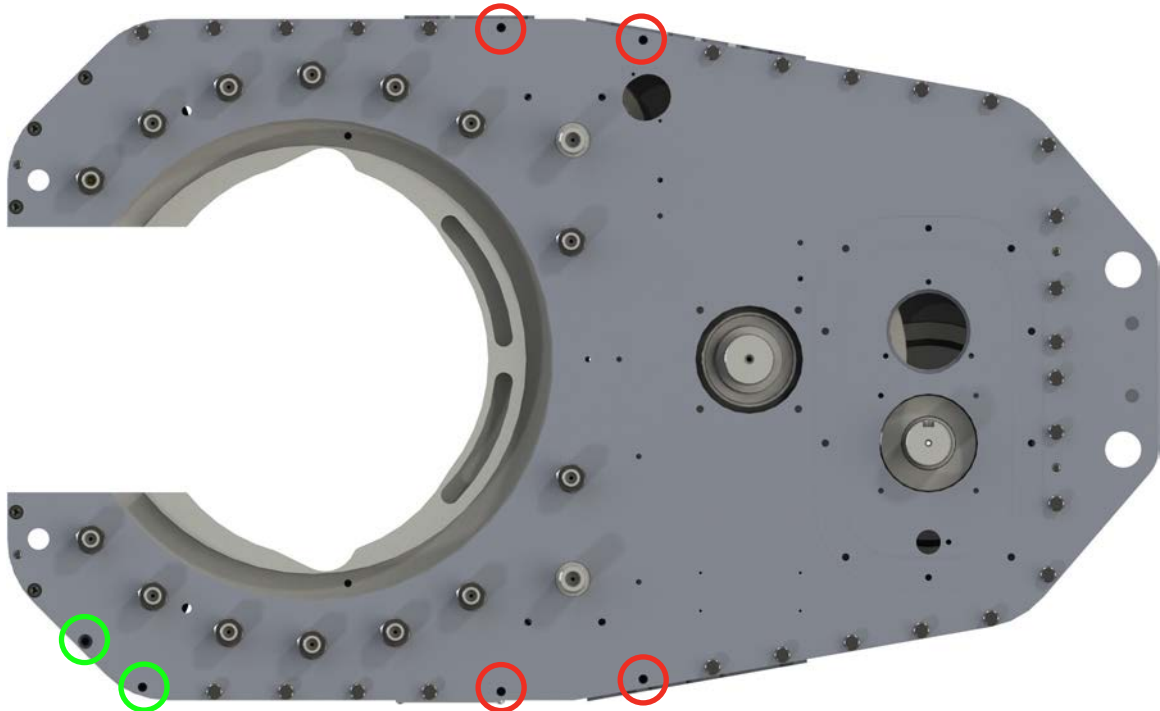


Illustration 3.1.8: Top Support Roller Assembly Drawing

35. Install fourteen support roller assemblies around the opening in the top plate, and secure each with a 1" UNC hex nut and 1" lock washer.
36. Locate the four un-threaded holes in the side body of the tong, two along the rear adjacent to each load cell pin and one just to either side of the front opening. If old dowel pins are in place, remove them before installation of the top plate. If the dowel pins are in any way damaged or deformed McCoy recommends replacing them with new 1/2" x 1-1/2" hardened dowel pins. If necessary clean the dowel pin holes. Do not insert dowel pins until after the top plate has been installed.

## 3.1 ASSEMBLY PROCEDURES (CONTINUED):

37. Use a temporary lifting sling and crane to maneuver the top plate weldment into position (weight = 490 lbs/223 kg), and place on to the side body. Insert the four positioning dowel pins (PN 09-0172) through the top plate into their respective holes in the side body. Use a hammer to tap the dowel pins until they are flush with the top plate.
38. Secure the top plate to the side body. Secure the perimeter of the top plate with twenty-seven  $\frac{1}{2}$ " UNC x 2- $\frac{1}{2}$ " hex bolts and  $\frac{1}{2}$ " lock washers, excluding the locations of the right and left rigid sling hangers and one door stop cylinder post, and five  $\frac{1}{2}$ " UNC x 2" hex socket head cap screws. Do not install fasteners in the rigid sling bracket mounting locations, shown circled in red in illustration 3.1.3, or the safety door switch plate mounting location, shown circled in green in illustration 3.1.9.



**Illustration 3.1.9: Top Plate Fastener Installation**

39. Drop the remaining components of the top clutch bearing over the inner race on the end of the splined clutch shaft.
40. Install the top clutch bearing retainer (PN 101-5925) on to the top plate over the top clutch bearing, and secure using four  $\frac{3}{8}$ " UNC x 1" hex socket flat-head counter-sunk cap screws. **ASSEMBLY NOTE:** Ensure the flat on the bearing plate is oriented toward the cutout in the top plate for the lower lay gear bearing.
41. Drop the remaining components of the top pinion bearing over the inner race on the end of the pinion gear shaft.
42. Install the top pinion bearing cap (PN 1393-89) over the top pinion bearing with the flat on the bearing cap facing toward the rear of the tong. Secure to the top plate with four  $\frac{1}{2}$ " UNC x 1- $\frac{1}{2}$ " hex bolts and  $\frac{1}{2}$ " lock washers.
43. Secure the top ends of the rotary idler shafts with idler pads (PN 101-6029) and 1- $\frac{1}{2}$ " UNC hex nylock nuts. **ASSEMBLY NOTE:** Tighten nylock nuts on support roller shafts only enough to eliminate vertical movement of the shafts. Do not place clamping force on the tong body by over-tightening the nut.
44. Secure the lay gear bearing retainer to the top plate using three  $\frac{3}{8}$ " UNC x 1" hex socket flat-head counter-sunk cap screws, orienting the flat to the flat on the top clutch bearing retainer.
45. Slide the top clutch bearing spacer (PN 101-5949) machined-side down over the top of the clutch shaft on to the top clutch bearing.
46. Insert the clutch drive gear shaft key (PN 101-5924) into the clutch shaft. Slide the clutch drive gear (PN 101-5950) over the end of the clutch shaft. Ensure the clutch drive gear is oriented so that the recess in the gear faces up. Secure the clutch drive gear with the clutch shaft plate (PN 1393-50-04) and a  $\frac{1}{4}$ " UNC x 1" flat head countersunk machine screw.

3.1 ASSEMBLY PROCEDURES (CONTINUED):

47. Press the inner race of the lower lay gear bearing (PN 1393-55) on to the bottom of the lay gear shaft (PN 101-5919) until the shoulder on the race contacts the shoulder on the shaft. **ASSEMBLY NOTE:** The end of the lay gear shaft threaded for a grease fitting is the **top** of the shaft. Press the inner race of the top lay gear bearing (PN 1393-55) on to the top of the lay gear shaft until the shoulder on the race contacts the shoulder on the shaft.

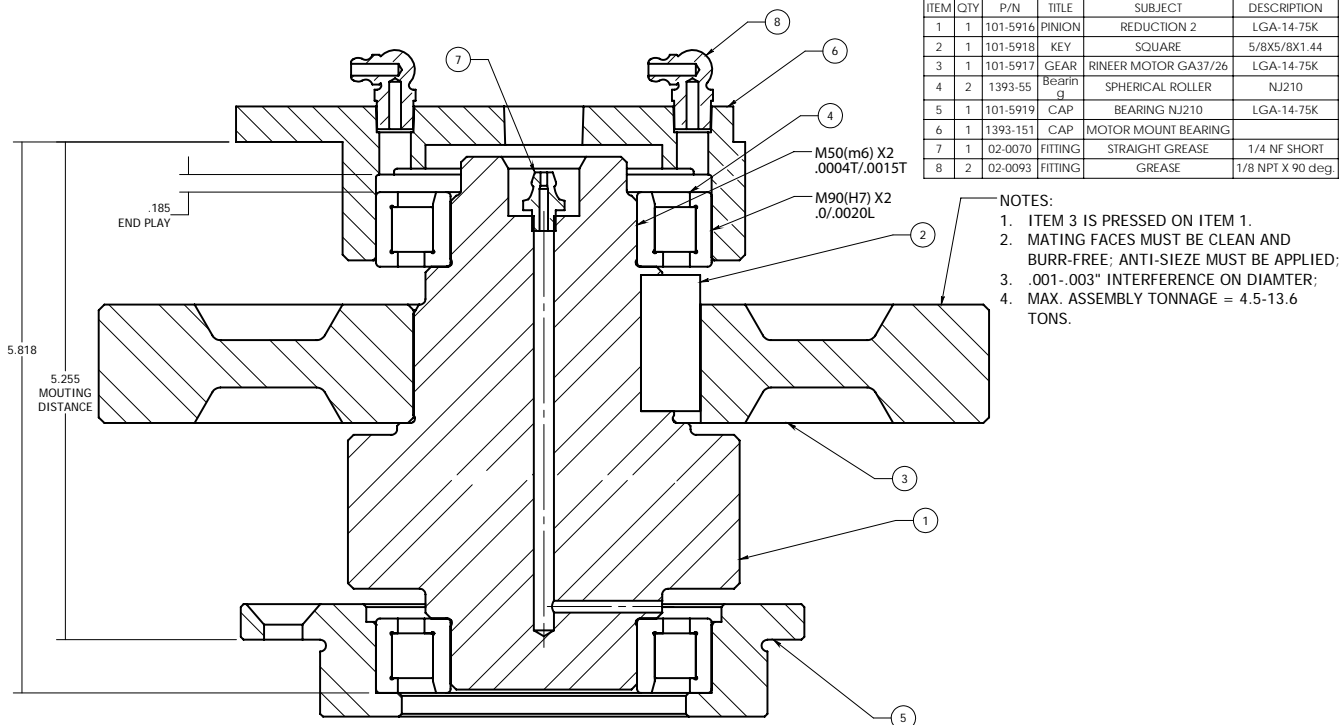


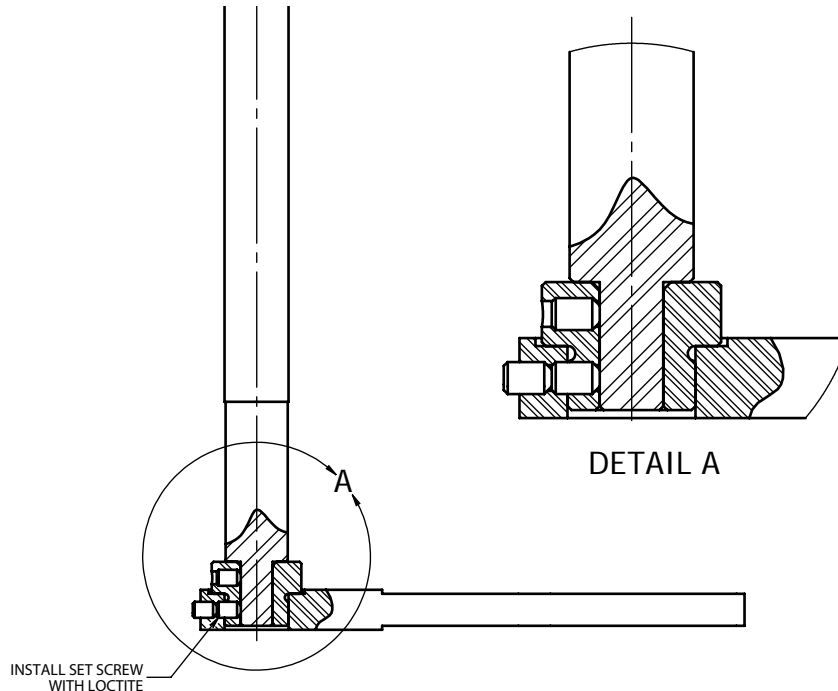
Illustration 3.1.10: Lay Gear Assembly Drawing

48. Insert the lay shaft gear key (PN 101-5918) into the slot on the lay shaft. Press the lay pinion gear (PN 101-5917) onto the shaft, over the key all the way to the small shoulder on the lay gear shaft.
49. Drop the remaining components of the lower lay gear bearing in to the lay gear bearing retainer.
50. Insert the inner race and bottom of the lay gear shaft in to the lower lay gear bearing. Mesh the lay gear with the clutch drive gear.
51. Place the lower shifter bushing (PN 1393-78) into its location in the top plate next to the clutch assembly. Secure in place using a 3/8" UNC x 1" hex socket thin head cap screw.
52. Locate the two un-threaded holes in the top plate on either side of the motor mount location. If old dowel pins are in place, remove them before installation of the motor mount. If the dowel pins are in any way damaged or deformed McCoy recommends replacing them with new 3/8" x 1-1/4" hardened dowel pins. If necessary clean the dowel pin holes. Do not insert dowel pins until after the motor mount has been placed on the top plate.
53. Place the motor mount weldment (PN 101-1808) in its proper location over the clutch and lay gear assembly. Press two 3/8" x 1-1/4" dowel pins into the top plate to position the motor mount weldment, one beside the clutch assembly and one beside the lay gear assembly. Secure the motor mount to the top plate using six 1/2" UNC x 1-1/4" hex socket head cap screws and 1/2" lock washers and two 1/2" UNC x 1-3/4" hex socket head cap screws and 1/2" lock washers to secure the torque gauge mount weldment (PN 101-1621) to the left side base of the motor mount (as seen from the rear).
54. Drop the remaining components of the top lay gear bearing over the inner race on the top end of the lay gear shaft.
55. Install the lay shaft bearing cap (PN 1393-151) on to the top of the motor mount over the top lay gear bearing. Secure bearing cap using four 3/8" UNC x 1" hex cap screws and 3/8" lock washers - ensure the flat on the bearing cap is oriented toward the cutout for the motor.
56. Thread two shifter detent tubes (PN 101-1497) into the top shifter bushing on the motor mount next to the shifter lug weldment. **ASSEMBLY NOTE:** Use red Loctite on the shifter detent tube threads. Thread detent into top shifter bushing until the shoulder on the tube contacts the bushing. Over-tightening the detent tubes will cause the tubes to snap off at the threads.
57. Lightly grease the shifting shaft (PN 101-6009). Insert it through the top shifter bushing, and rotate it while pushing down through the lower shifter bushing until the shoulder of the shifting shaft makes contact with the shifting fork.



## 3.1 ASSEMBLY PROCEDURES (CONTINUED):

58. Securely fasten the shifting fork to the shifting shaft using three  $\frac{1}{4}$ " UNC x  $\frac{3}{8}$ " thin nylock nut. **ASSEMBLY NOTE:** Apply red Loctite to all three set screws when installing (see illustration 3.I.11, shifting fork assembly drawing).

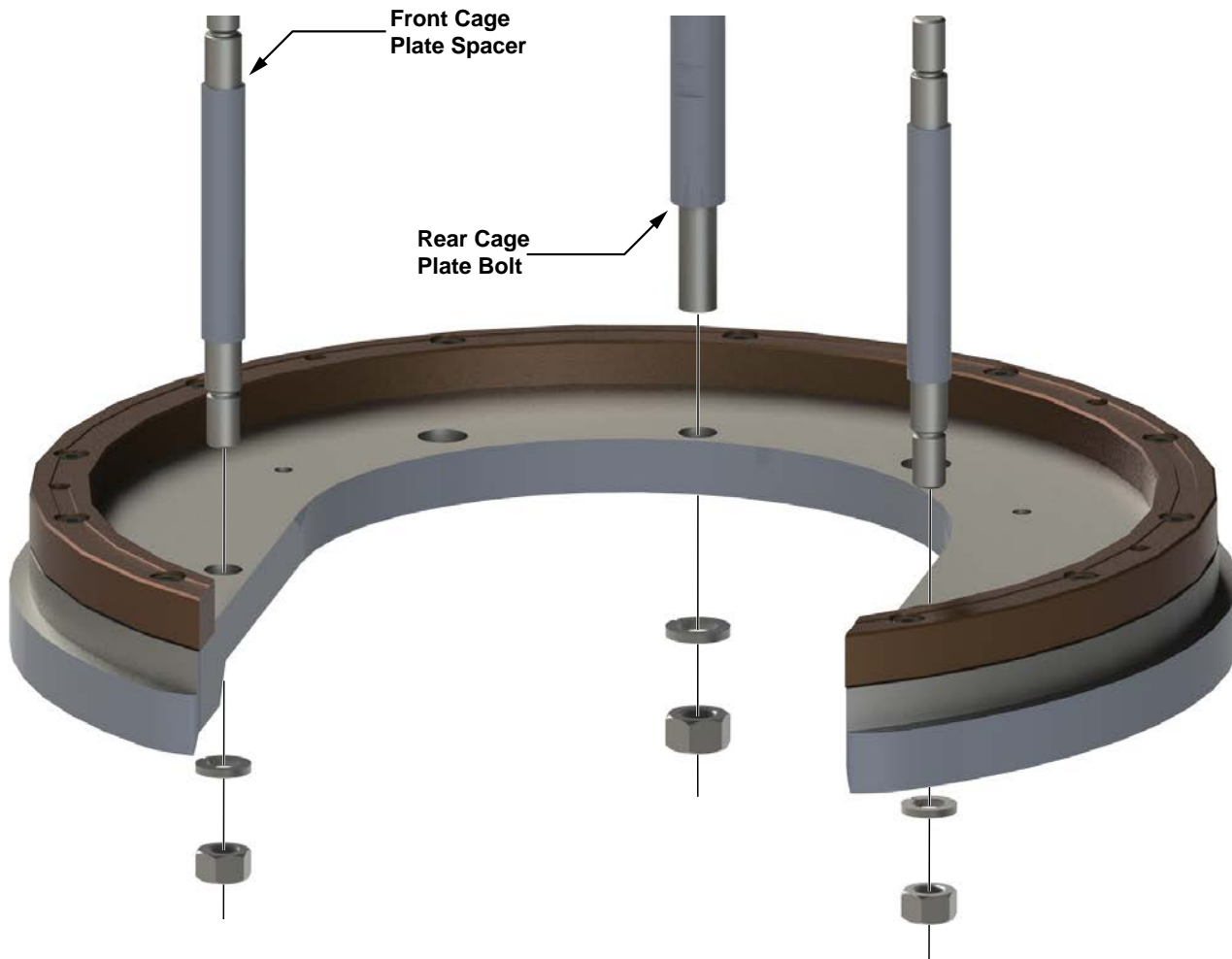


**Illustration 3.I.11: Shifting Fork Assembly Drawing**

59. Insert a shifter detent ball (PN 02-0018) into each detent tube followed by a detent spring (PN 997-0-64). Thread a  $\frac{7}{16}$ " UNF hex jam nut on to a  $\frac{7}{16}$ " UNF x  $1-\frac{1}{4}$ " hex bolt, and thread the hex bolt in to one of the detent tubes. Repeat the procedure with a second nut and bolt, and thread into the second detent tube. **ASSEMBLY NOTE:** Do not use Loctite on the  $\frac{7}{16}$ " bolts or locking nuts. Do not torque locking nuts - tighten to only  $\frac{1}{16}$  rotation past hand-tight to avoid snapping the shifter detent tube from the top shifter bushing.
60. Press the motor gear key (101-3596) into the shaft of the hydraulic motor (PN 87-0130). Slide the motor gear (PN 101-5951) over the shaft and key and secure in place with three  $\frac{1}{4}$ " UNC x  $\frac{3}{8}$ " hex socket set screws. Use the same set screw arrangement as used when attaching the shifting fork to the shifting shaft (see Step 58)
61. Secure the motor to the motor mount using four  $\frac{3}{4}$ " UNC x  $1-\frac{3}{4}$ " hex cap screws and  $\frac{1}{2}$ " lock washers. Ensure the hydraulic ports on the motor face toward the front of the tong.
62. Attach shifting handle weldment (PN 101-1749) to the shifter shaft and pivot arms using two  $\frac{3}{8}$ " x  $1-\frac{1}{2}$ " clevis pins - secure the pins with cotter pins.
63. Attach a support ring (PN 1393-23) to the inside of the top cage plate (PN 1393-21) using eleven  $\frac{1}{2}$ " x  $1-\frac{3}{4}$ " shoulder bolts and  $\frac{3}{8}$ " UNC nylock nuts.
64. Attach a support ring to the inside of the bottom cage plate (PN 1393-22) using eleven  $\frac{1}{2}$ " x  $1-\frac{3}{4}$ " shoulder bolts and  $\frac{3}{8}$ " UNC nylock nuts.

## 3.1 ASSEMBLY PROCEDURES (CONTINUED):

65. Secure two cage plate spacers (PN 101-3630) and the rear cage plate bolt (PN 1393-36) to the bottom cage plate using  $\frac{3}{4}$ " lock washers and  $\frac{3}{4}$ " UNC hex nuts.

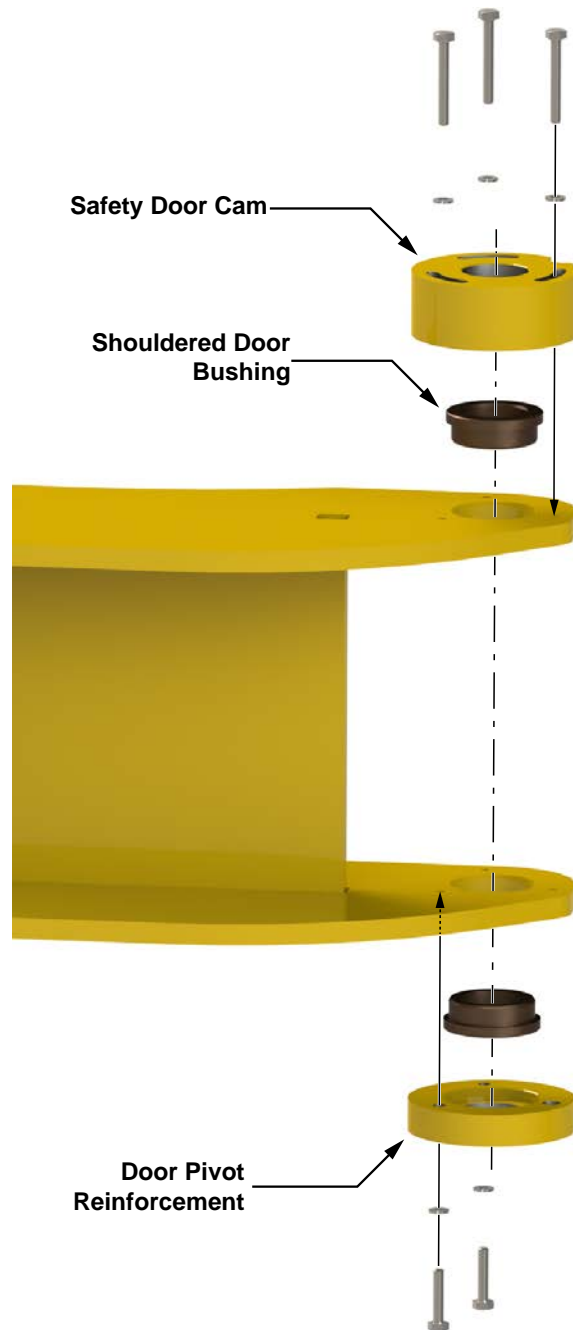


**Illustration 3.1.12: Cage Plate Spacer Installation**

66. Position the bottom cage plate assembly under the rotary gear with the guide ring in the groove in the rotary gear. Place the top cage plate on to the rotary gear and cage plate spacers. Secure the tops of the front cage plate spacers using a  $\frac{3}{4}$ " lock washer and a  $\frac{3}{4}$ " UNC hex nut. Secure the top of the rear cage plate bolt/spacer to the top cage plate using two  $\frac{7}{8}$ " UNC hex nuts.
67. Fasten the brake band adjustment bolt retainers (PN 101-5965) to the top and bottom plates using two  $\frac{5}{8}$ " UNC x 1- $\frac{3}{4}$ " hex socket head cap screws per retainer.
68. Install the top and bottom brake band weldments (PN 101-5966). Attach the pivot ends of the brake band weldments to the top and bottom plates using one  $\frac{3}{4}$ " x 1" hex socket UNC shoulder bolt and one  $\frac{5}{8}$ " lock washer per weldment. Secure the adjustment ends to each other through the adjustment bolt retainers using one  $\frac{1}{2}$ " UNC x 8" hex bolt, a brake band adjustment spring (PN 1404-29-04), and one  $\frac{1}{2}$ " UNC hex nylock nut. See Pp. 5.30 - 5.31 for configuration.
69. Place the larger end of the backing pin retainer (PN 1393-40) over the rear cage plate bolt. Thread a  $\frac{7}{8}$ " UNC nylock nut on to the top of the rear cage plate bolt.
70. Place the backing pin (PN 1393-39) in to one of the backing pin holes in the rear of the top cage plate. Attach the backing pin retainer to the backing pin using the backing pin knob (02-0017).
71. Press a door pivot shoulder bushing (PN 101-5987) in to the top and bottom plate of the door weldment (PN 101-5978) See illustration 3.1.13 next page.

## 3.1 ASSEMBLY PROCEDURES (CONTINUED):

72. Install the safety door cam (PN 101-5988) on to the top door plate over the shoulder bushing using three  $\frac{1}{4}$ " UNC x 2" hex bolts and  $\frac{1}{4}$ " lock washers. Install the bottom door pivot reinforcement (PN 101-5989) over the shoulder bushing using two  $\frac{1}{4}$ " UNC x 1- $\frac{1}{4}$ " hex bolts and  $\frac{1}{4}$ " lock washers. **ASSEMBLY NOTE:** Do not install a third  $\frac{1}{4}$ " UNC x 1- $\frac{1}{4}$ " hex bolt and  $\frac{1}{4}$ " lock washer on the bottom door pivot reinforcement - a door spring return cylinder mounting lug will be installed in a later step.

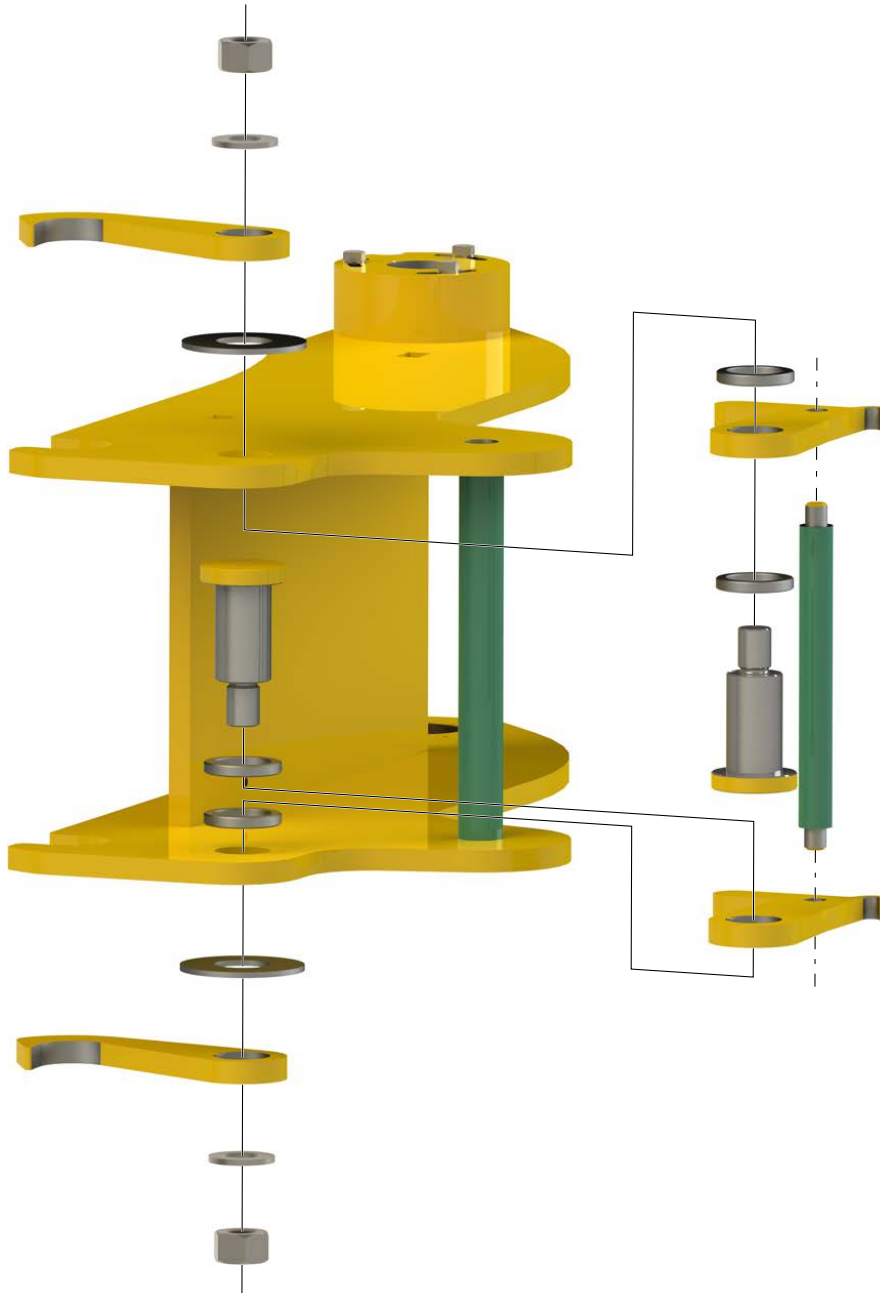


**Illustration 3.I.13: Safety Door Cam & Lower Reinforcement Installation**

## 3.1 ASSEMBLY PROCEDURES (CONTINUED):

73. Install door latch assembly. Refer to illustration 3.I.14 during latch installation:

- i. Slide a latch lever bushing (PN 101-5997) over each door latch pin (PN 101-5986).
- ii. Assemble latch handle (PN 101-5984) and two latch levers (PN 101-5985). Note that the components are press-fit only.
- iii. Place the latch handle/lever assembly in its location in the door weldment. Ensure the remaining two latch lever bushings (PN 101-5997) are placed between the latch levers and the insides of the top and bottom door plates. Insert each latch pin through the latch levers ensuring the slot in each latch pin aligns with the tooth on each latch lever.
- iv. Slide a wide latch bushing (PN 101-4885) over the top latch pin, followed by a latch claw (PN 101-5982) ensuring the tooth on the latch claw aligns with the slot on the latch pin. Secure the latch claw with a  $\frac{3}{4}$ " UNC hex nylock nut and  $\frac{3}{4}$ " narrow flat washer. **ASSEMBLY NOTE:** Do not over-tighten nylock nut. Ensure the latch claw is able to rotate freely.
- v. Repeat Step 62(iv) for bottom latch claw.



**Illustration 3.I.14: Door Latch Installation**

## 3.1 ASSEMBLY PROCEDURES (CONTINUED):

74. Insert the door latch post (PN 101-6068) through the top and bottom plate, just to the right of the tong opening at the front of the tong. Slide a latch spacer (PN 101-5991) over the top and bottom of the latch post, and secure the top and bottom with a 1" UNC hex nylock nut (see illustration 3.1.15).
75. Install the door (see illustration 3.1.15).
  - i. Support the door assembly with a temporary lifting sling and a crane (weight = 80 lbs /36.4 kg).
  - ii. Align the door weldment with the pivot holes in the top and bottom plates.
  - iii. Insert a door pivot bushing (PN 101-5990) between the door weldment and the top and bottom door plates.
  - iv. Insert the top door bushing (PN 101-5992) in to the safety door cam, and insert the bottom door bushing (PN 101-5991) in to the bottom door reinforcement.
  - v. Lightly grease the door pivot shaft (PN 101-5976). Insert the door pivot shaft from the top through the door plates, tong plates, and bushings.
  - vi. Secure the door pivot shaft on the top and bottom using a 1" UNC nylock nut.

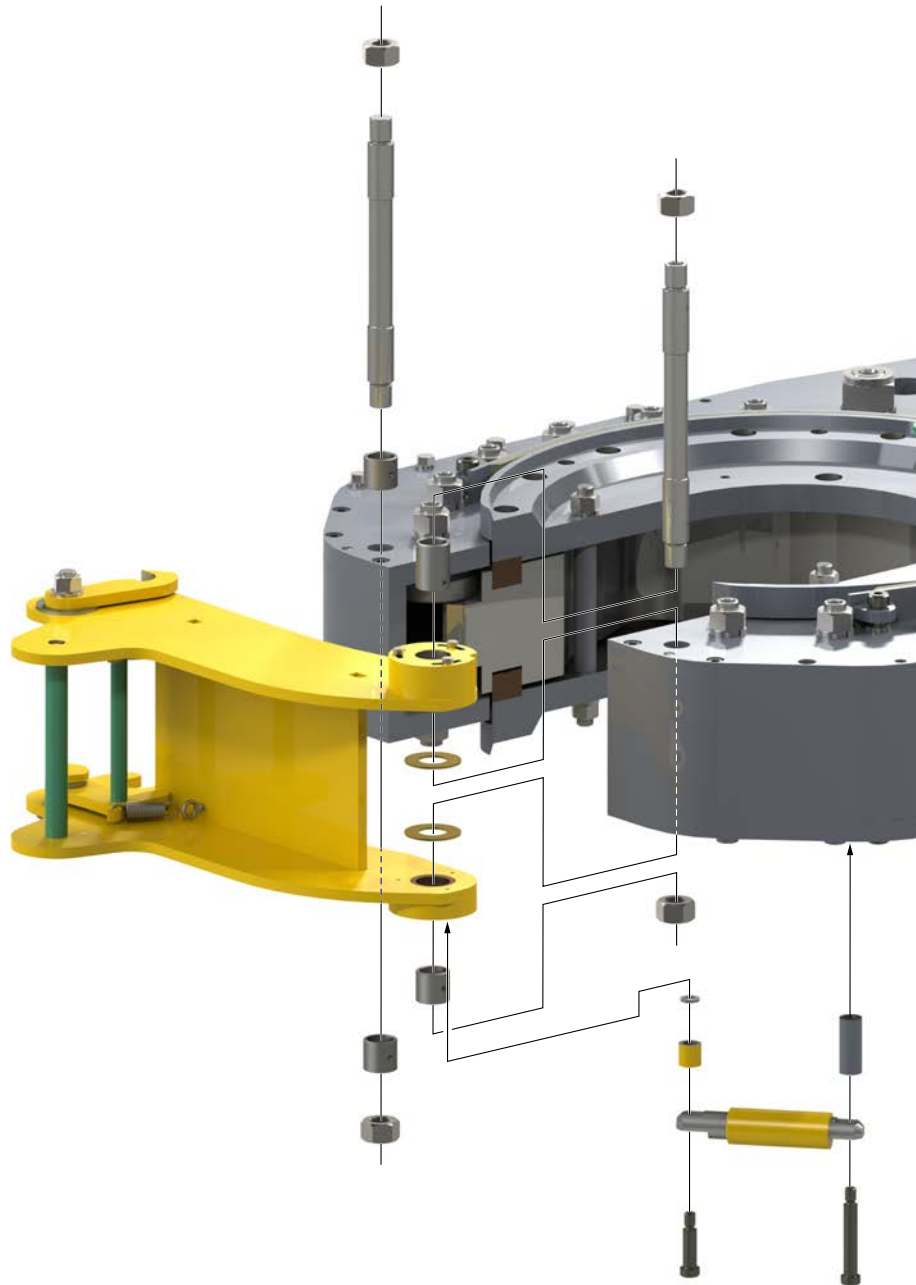
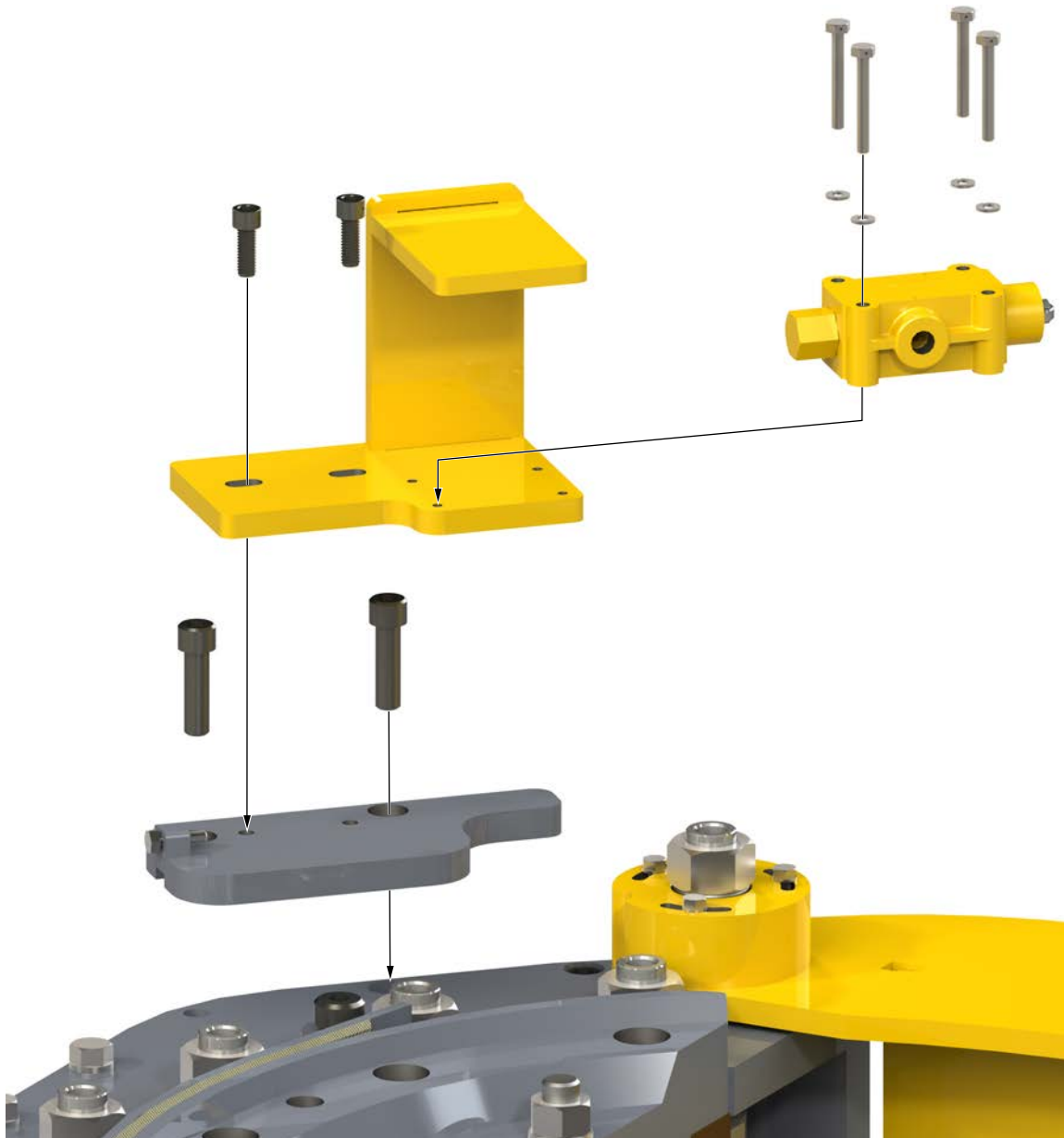


Illustration 3.1.15: Door Installation

## 3.1 ASSEMBLY PROCEDURES (CONTINUED):

76. Attach one side of the door spring stop cylinder (1037-A4-144) to the door pivot reinforcement using a  $\frac{5}{8}$ " x 1- $\frac{3}{4}$ " hex socket UNC shoulder bolt, short mounting lug (PN 101-6000) and  $\frac{1}{2}$ " lock washer.
77. Attach the second side of the door spring stop cylinder to the bottom plate of the tong using a  $\frac{5}{8}$ " x 3- $\frac{1}{4}$ " hex socket UNC shoulder bolt and long mounting lug (PN 101-5996).
78. Attach the safety door mounting plate weldment (PN 101-5974) to the top plate of the tong using two  $\frac{1}{2}$ " UNC x 1- $\frac{3}{4}$ " hex socket head cap screws. **ASSEMBLY NOTE:** Fasteners that have inadvertently been installed in this mounting location must be removed before weldment is installed.
79. Attach the safety door switch (PN 02-E0190) to the safety door valve guard weldment (PN 101-5972) using four  $\frac{1}{4}$ " UNC x 2" drilled hex bolts (PN 101-6072) and  $\frac{1}{4}$ " lock washers.
80. Secure the safety door valve guard weldment to the safety door mounting plate weldment using two  $\frac{3}{8}$ " UNC x 1" drilled hex socket head cap screws (PN 02-E0249).
81. Thread a  $\frac{1}{4}$ " UNC x 1" hex bolt or hex socket head cap screw in to the safety door mounting plate weldment to be used as an adjustment screw.

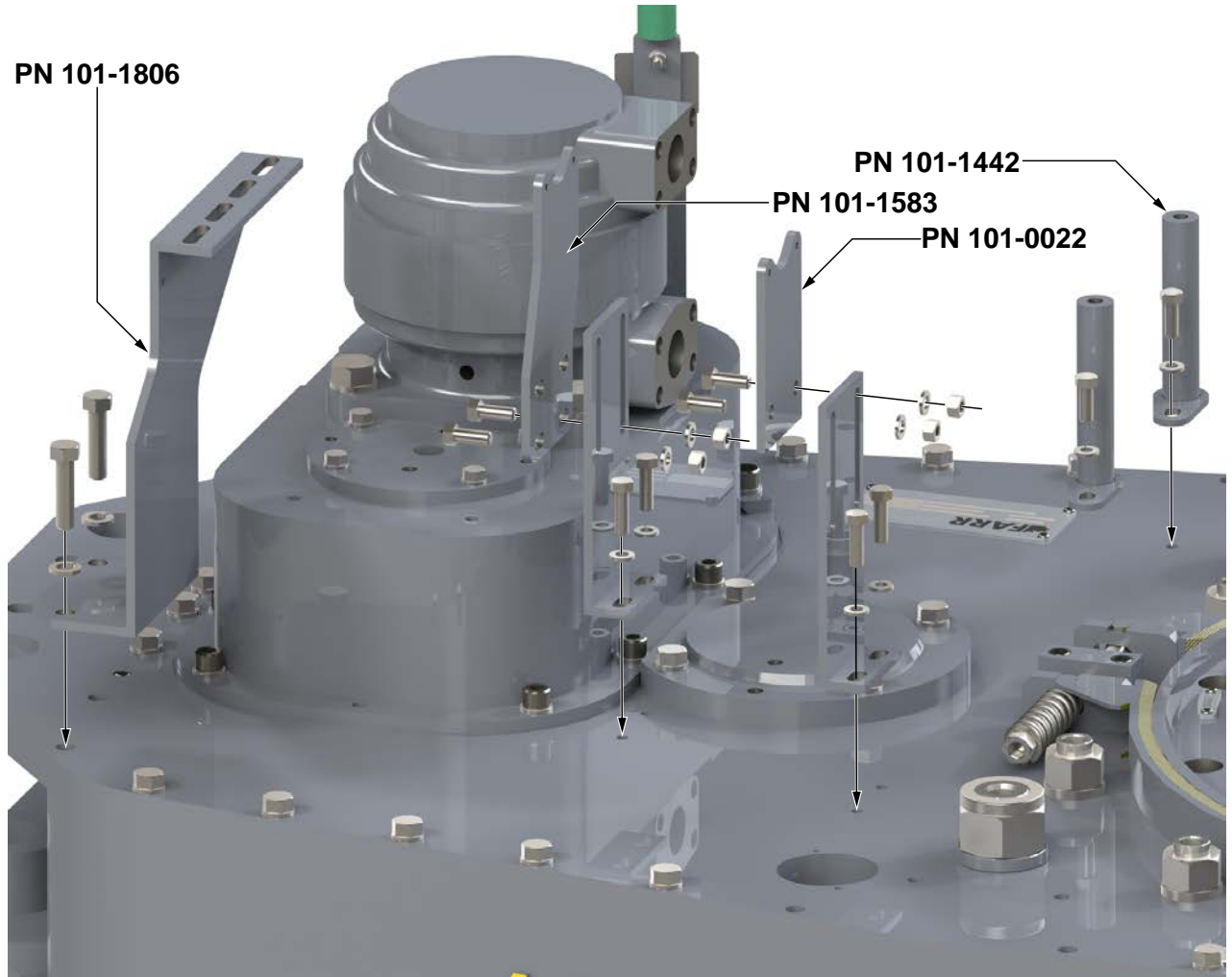


**Illustration 3.1.16: Safety Door Switch Installation**



## 3.1 ASSEMBLY PROCEDURES (CONTINUED):

82. Mount the two hydraulic valve mount weldments (PN 101-1442) to the top plate using one  $\frac{3}{8}$ " UNC x 1" hex bolt and  $\frac{3}{8}$ " lock washer per weldment (see illustration 3.1.17).
83. Mount two hydraulic support L-base weldments (PN 101-1138) to the top plate to the front right of the motor mount weldment using two  $\frac{3}{8}$ " UNC x 1- $\frac{1}{4}$ " hex bolts and  $\frac{3}{8}$ " lock washers per weldment (see illustration 3.1.17).
84. Attach the rear hydraulic support weldment (PN 101-1806) at the right rear of the tong behind the motor mount weldment using two  $\frac{1}{2}$ " UNC x 2" hex bolts and  $\frac{1}{2}$ " lock washers (see illustration 3.1.17). **ASSEMBLY NOTE:** Remove the fasteners that may have been previously installed before attaching the support weldment.

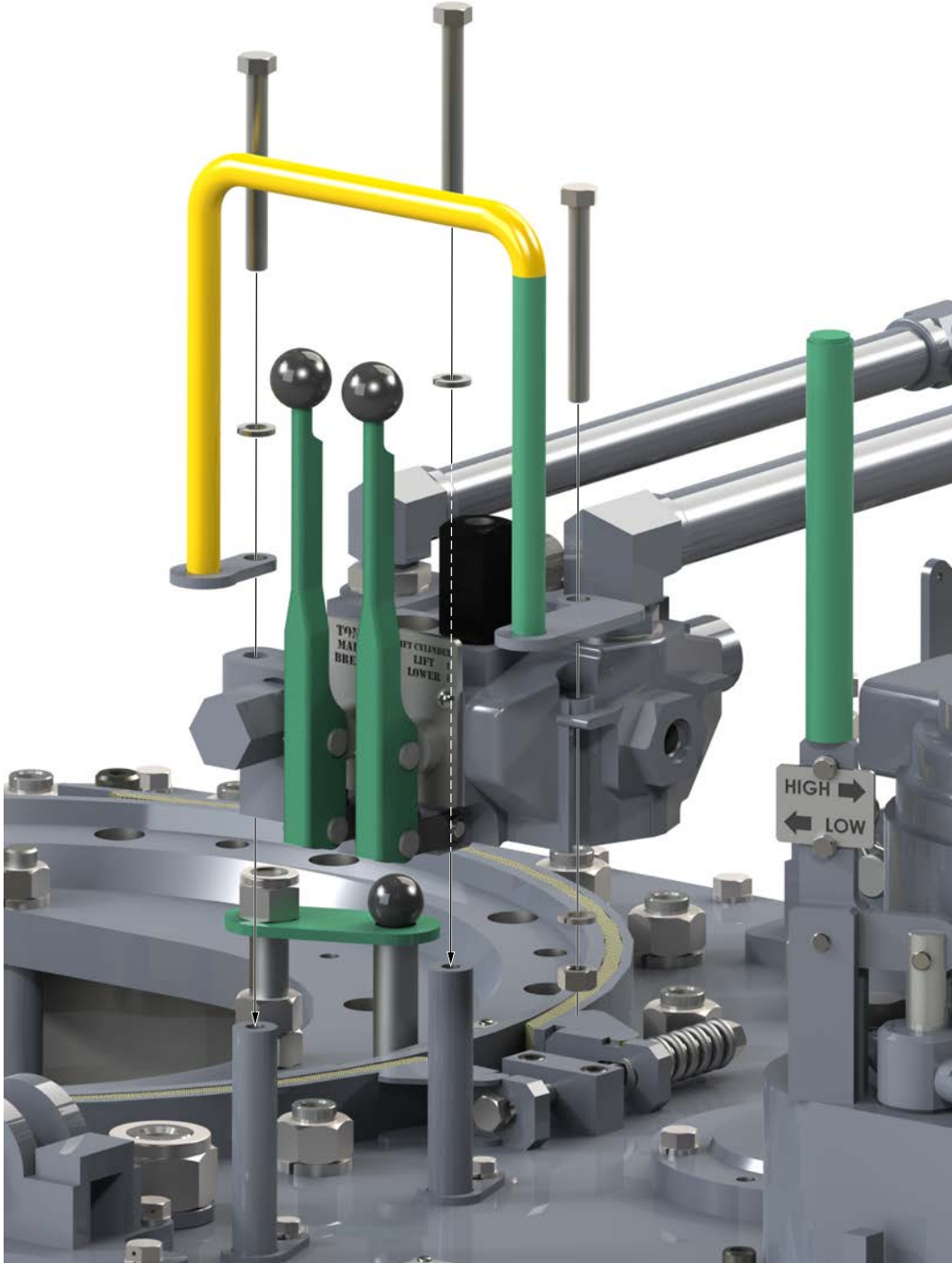


**Illustration 3.1.17: Hydraulic Support Installations**

85. Fasten hydraulic support adjustment plate (PN 101-0022) to the forward-most support mount base using two  $\frac{3}{8}$ " UNC x 1" hex bolts, two  $\frac{3}{8}$ " lock washers, and  $\frac{3}{8}$ " UNC nuts.
86. Fasten hydraulic support adjustment plate (PN 101-1538) to the middle support mount base (at the RH front corner of the motor mount) using two  $\frac{3}{8}$ " UNC x 1" hex bolts, two  $\frac{3}{8}$ " lock washers, and  $\frac{3}{8}$ " UNC nuts (see illustration 3.1.9).
87. Attach the rigid sling brackets (LH = PN 101-5581, RH = PN 101-5595) to the top plate of the tong using two  $\frac{1}{2}$ " UNC x 2- $\frac{1}{2}$ " drilled hex bolts (PN 101-6071) and  $\frac{1}{2}$ " lock washers (outside of weldments, into the side body weldment), and two  $\frac{1}{2}$ " UNC x 1- $\frac{3}{4}$ " drilled hex bolts (PN 101-6070) and  $\frac{1}{2}$ " lock washers (inside of each weldment, into top plate).
88. Bolt four leg weldments (PN 997-D8-160A) to the bottom plate using one  $\frac{7}{8}$ " UNC x 1- $\frac{1}{4}$ " hex socket head cap screw and one regular  $\frac{7}{8}$ " flat washer per leg weldment.

## 3.1 ASSEMBLY PROCEDURES (CONTINUED):

89. Use a crane and temporary lifting sling to transport the assembled hydraulic valve bank to the top plate of the tong (weight = 90 lbs / 40.9 kg). Bolt the assembled hydraulic valve bank to the valve supports installed in Step 73 using two ½" UNC x 4-½" hex bolts and four ½" narrow flat washers. **ASSEMBLY NOTE:** Install the valve handle guard weldment (PN CE-HANDLE-2) while installing the valve assembly. Secure one side of the guard weldment using one of the bolts attaching the valve assembly to the valve mount weldment, and secure the other side to the end of the valve assembly using an additional ½" UNC x 4-½" hex bolt and ½" narrow flat washer (see illustration 3.1.18).

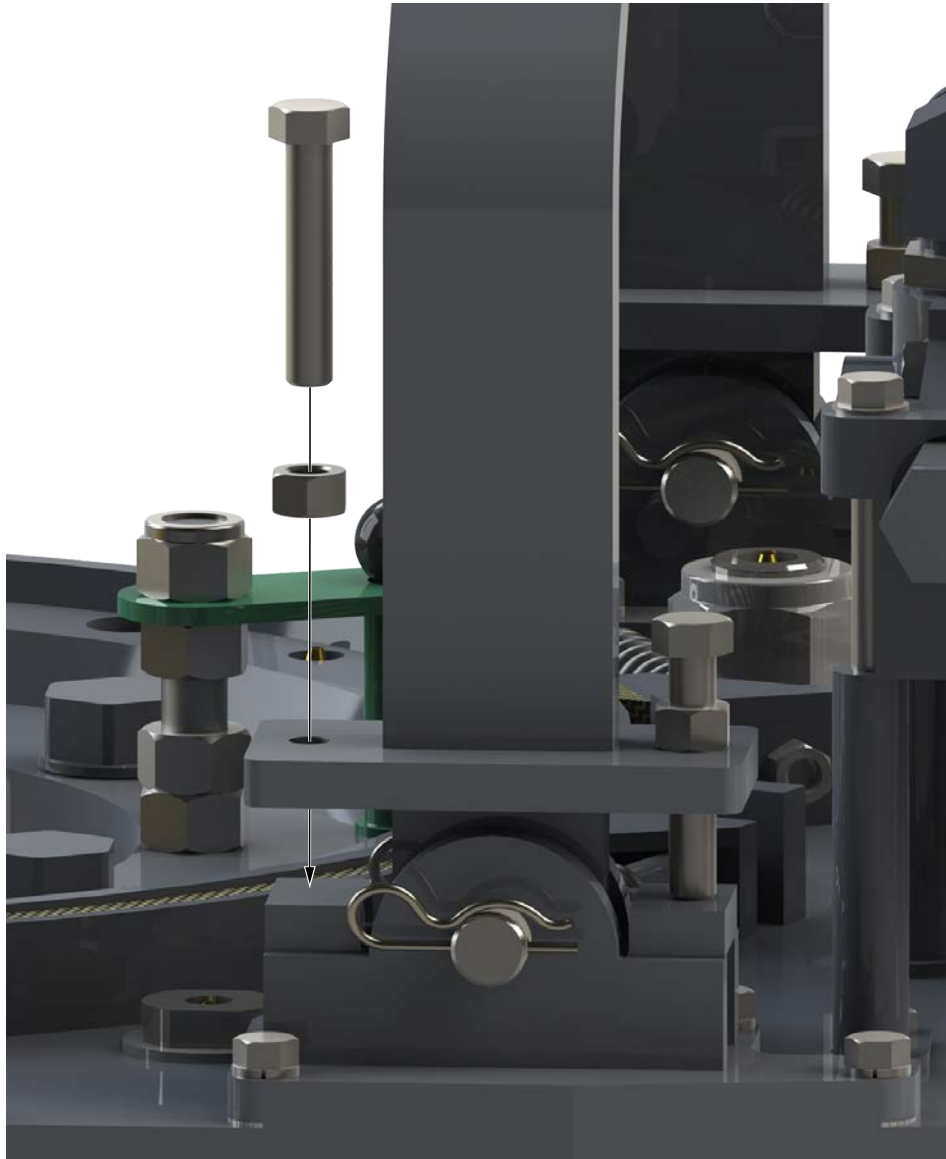


**Illustration 3.1.18: Hydraulic Valve Assembly Installation**

90. Secure the inlet and discharge lines to the hydraulic support structures installed in Steps 73 - 75.
91. Attach remainder of hydraulic components, and make hydraulic connections where necessary. **ASSEMBLY NOTE:** Ensure hydraulic connections are performed by an authorized hydraulic technician, in accordance with the supplied hydraulic schematic.

## 3.1 ASSEMBLY PROCEDURES (CONTINUED):

90. Install the rigid sling.
  - a. If not already done, slide the master lifting link (PN 02-9128) over the adjustment helix (PN 1095-220), and install the adjustment helix in the rigid sling weldment (PN 101-5583) using the rigid sling helix pin (PN 1095-218) and a 1- $\frac{1}{4}$ " UNC thin nylock nut.
  - b. Use a crane to hoist the rigid sling assembly (weight = 80 lbs / 36.4 kg). Connect the rigid sling assembly to the rigid sling mounting lugs with rigid sling hanger pins (PN 997-955). Secure each pin with two "R" hitch pins (PN 02-0981).
  - c. Thread a  $\frac{5}{8}$ " UNC hex nut on to each of four  $\frac{5}{8}$ " UNC x 3- $\frac{1}{2}$ " rigid sling leveling bolts. Thread the leveling adjustment weldments into each side of the rigid sling weldment mounting brackets, roughly adjusting them so the rigid sling is approximately perpendicular to the top plate of the tong (see illustration 3.1.19).



**Illustration 3.1.19: Rigid Sling Leveling Bolt Installation**

**3.1 ASSEMBLY PROCEDURES (CONTINUED):**

91. Install grease fittings in tong:

- i) Install one ¼" straight thread grease fitting (PN 02-0097) into the top of each roller cup half-shaft mounted in the top and bottom plates (28 locations total).
- ii) Install one ⅛" NPT grease fitting (PN 02-0005) into the end of each rotary idler assembly, located on the top face of the tong (2 total).
- iii) Install two ⅛" NPT grease fittings (PN 02-0005) into the bottom plate of the tong adjacent to each pinion idler assembly, located on the bottom face of the tong (4 total).
- iv) Install two ⅛" NPT 90° grease fittings (PN 02-0093) in each pinion bearing cap (4 total).
- v) Install one ⅛" NPT grease fitting (PN 02-0005) into the end of the clutch shaft, in the centre of the clutch bearing cap.
- vi) Install two ⅛" NPT 90° grease fittings (PN 02-0093) in clutch bearing cap (two locations total).
- vii) Install one ⅛" NPT grease fitting (PN 02-0005) into the end of the lay gear shaft, in the centre of the lay gear bearing cap.
- viii) Install two ⅛" NPT 90° grease fittings (PN 02-0093) in lay gear bearing cap (two locations total).
- ix) Install two ⅛" NPT grease fitting (PN 02-0005) in the top of the motor mount directly adjacent to the lay gear bearing cap.
- x) Install four ⅛" NPT grease fittings (PN 02-0005) in each cage plate (8 total).
- xi) Install one ⅛" NPT grease fitting (PN 02-0005) into the end of the door pivot shaft on the top of the safety door cam.

## 3.J DAILY INSPECTION &amp; MAINTENANCE CHECKLIST (POWER TONG)

McCoy Global recommends that the following inspection and maintenance procedures be performed before each use, and at least once per day when the tong is in steady use, in the order in which they are listed.

1.  Rotate cage plate/rotary gear until the opening in the rotary gear faces towards the rear of the tong.



**DO NOT PERFORM ANY FURTHER ACTIONS OR MAINTENANCE WHILE THE TONG IS CONNECTED TO ANY HYDRAULIC POWER SUPPLY. MCCOY RECOMMENDS THAT ALL HYDRAULIC LINES ARE FULLY DISCONNECTED, AND RESIDUAL HYDRAULIC PRESSURE IS BLED OFF. ENSURE ADEQUATE CONTAINMENT IS IN PLACE TO PREVENT ENVIRONMENTAL CONTAMINATION FROM RESIDUAL HYDRAULIC FLUID.**

**DEPRESSURIZE HYDRAULIC SYSTEM IN PREPARATION FOR MAINTENANCE:**

2.
- 1) Rotate the tong to the "open throat" position. Ensure tong and backup doors (if equipped) are closed. Fully extend the lift cylinder
  - 2) De-energize the power unit.
  - 3) Repeatedly actuate the tong motor control valve lever IN BOTH DIRECTIONS to dissipate any residual pressure in the valve and motor.
  - 4) Remove the hydraulic SUPPLY line from the equipment.
  - 5) Repeatedly actuate the remaining control valve levers IN BOTH DIRECTIONS to dissipate any residual pressure in the remainder of the hydraulic control system.
  - 7) Disconnect the hydraulic RETURN line from the equipment.
  - 8) Disconnect remaining hoses such as case drains, or lines connected to the turns counter.



**HYDRAULIC PRESSURES AS HIGH AS OPERATING PRESSURE MAY REMAIN TRAPPED IN SMALL AREAS OF THE EQUIPMENT. ENSURE ALL MAINTENANCE IS CARRIED OUT BY A QUALIFIED SERVICE TECHNICIAN, AND THAT ADEQUATE PERSONAL PROTECTIVE EQUIPMENT IS USED TO GUARD AGAINST PRESSURE INJURIES**

3.  Perform an initial wash of the tong in order to remove the majority of dirt and grease build-up. Ensure adequate containment is in place to prevent environmental contamination from residual hydraulic fluid and dirty grease.
4.  Remove the access panel on the side of the tong directly adjacent to the shifter mechanism.
5.  Use a flashlight to perform a visual inspection of the gear train through the access panel and the opening of the rotary gear. If gear damage or chips of metal are seen, the tong should be removed from service and overhauled to avoid further damage. Replace access panel when inspection is complete.
6.  Perform a visual inspection of all fasteners and protruding body pieces (example: hydraulic valve mounts, inlet & outlet line supports, tong legs, shifter handle pivot lugs). Tighten or replace loose or missing fasteners. McCoy recommends that damaged or missing body parts be repaired or replaced as soon as possible.
7.  Inspect the jaws and dies. Inspect the jaw roller pins for signs of damage - replace pins if necessary. If the pins are welded in place, replace the entire jaw assembly. Ensure dies are secure in the jaw - replace worn dies if necessary. Ensure that the jaw rollers rotate freely. Check to ensure the size of the loaded jaws match the size of casing or pipe you are running.
8.  Perform a visual inspection of all lifting points - if visible damage is seen, including cracks, broken lugs, distorted metal, etc. replace damaged part(s) before placing tong in service. Also inspect all chains, master links, and turnbuckles - again, if any damage is noted replace the damaged part(s) before placing the tong in service.
9.  Inspect tong for signs of premature wear, or moving parts that are rubbing (bare metal where there used to be paint is a good indication of wear).
10.  Inspect backing pin(s). If cracked, broken, or bent it (they) must be replaced.
11.  Inspect top and bottom brake band linings - replace if necessary. Unequal wear of the brake bands indicates that the brake band tension is not evenly adjusted. Refer to the maintenance section of the manual for instructions on properly adjusting brake bands.
12.  Perform a visual inspection of all hydraulic lines. Replace flexible lines if they appear to be cracked, fatigued, or have visible signs of wear from contact with a rigid object.
13.  Perform a visual inspection of all hydraulic lines. Replace flexible lines if they appear to be cracked, fatigued, or have visible signs of wear from contact with a rigid object.

14.  Perform a complete greasing of the tong - refer to Maintenance section of the technical manual
15.  Ensure main supply and return connections to the tong are fully made up. Re-connect the remainder of the hydraulic lines, and, if applicable, the electrical line to the turns counter.



**FAILURE TO ENSURE THAT THE SELF-SEALING SUPPLY AND RETURN LINES ARE FULLY MADE UP MAY RESULT IN CATASTROPHIC EQUIPMENT FAILURE.**

If using a stand-alone power unit, start it now - refer to the power unit technical manual for startup procedures. Listen to power unit for a moment to see if there are any unusual mechanical sounds (rubbing, grinding, excessive pump noise). If using a diesel unit, allow sufficient time for the engine to reach operating temperature before increasing engine RPM. Once engine is warm, gradually increase engine RPM until operating speed is reached.

16.  Ensure that supply pressure is at or above the tong's specified operating pressure, and that the return pressure is less than 350 psi.
17.  Perform a visual inspection of pressurized hydraulic lines. Document and correct any hydraulic fluid leaks.
18.  Perform a full functional test of the tong. Report and correct any hydraulic leaks from the hydraulic valve bank, or from any hydraulic cylinders that are used.
19.  Perform a visual inspection of the load cell. If using a tension load cell, replace any cracked, broken, or distorted components including links and chains. If using a compression load cell, replace any component that has been crushed or otherwise distorted through compression.
20.  If applicable, inspect the load cell anchor pins (tension load cell only). Replace the anchor pins if cracking or metal distortion is seen.
21.  If applicable, the weld securing the single load cell anchor to the bridge bar main plate must be inspected (compression load cell only). If the integrity of the weld has been compromised, the tong must be removed from service until the weld is repaired. The load cell beam will need to be disconnected and removed so the weld is visible. Before re-installing the beam, liberally grease the anchor pin before reinserting into the load cell beam.
22.  Test safety door feature (if equipped). Open the tong door(s), and attempt to rotate the cage plate at low speed (low gear) in both directions (makeup and breakout). If cage plate begins rotating, the safety door mechanism is not functional, and the tong must be removed from service until the safety door mechanism can be repaired. If the safety door is operating correctly, cage plate rotation will not be inhibited once the door is closed and latched.



**NEVER OPERATE YOUR EQUIPMENT WITH A BYPASSED OR MALFUNCTIONING SAFETY DOOR**

23.  While rotating the cage plate, ensure that the jaws properly cam. If the jaws do not cam properly, the brake bands need to be tightened. Incrementally adjust both the top and bottom brake bands EQUALLY until proper cam action is achieved (see section 3.E.1).



## 3.K MONTHLY MAINTENANCE CHECKLIST - POWER TONG

The following maintenance checklist is intended as a guideline rather than a definitive maintenance schedule. Your equipment may require more, or less, maintenance depending upon the frequency of use, the percentage of maximum torque that your equipment is routinely subjected to, and the field conditions under which your equipment operates. McCoy Global recommends that the following inspection and maintenance procedures be performed monthly, or in conjunction with your maintenance foreman's experience and best estimate of when your equipment is due for this maintenance.

1.  Rotate cage plate/rotary gear until the opening in the rotary gear faces towards the rear of the tong.



**DO NOT PERFORM ANY FURTHER ACTIONS OR MAINTENANCE WHILE THE TONG IS CONNECTED TO ANY HYDRAULIC POWER SUPPLY. MCCOY GLOBAL RECOMMENDS THAT ALL HYDRAULIC LINES ARE FULLY DISCONNECTED, AND RESIDUAL HYDRAULIC PRESSURE IS BLED OFF. ENSURE ADEQUATE CONTAINMENT IS IN PLACE TO PREVENT ENVIRONMENTAL CONTAMINATION FROM RESIDUAL HYDRAULIC FLUID.**

**DEPRESSURIZE HYDRAULIC SYSTEM IN PREPARATION FOR MAINTENANCE:**

2.
- 1) Rotate the tong to the "open throat" position. Ensure tong and backup doors (if equipped) are closed. Fully extend the lift cylinder
  - 2) De-energize the power unit.
  - 3) Repeatedly actuate the tong motor control valve lever IN BOTH DIRECTIONS to dissipate any residual pressure in the valve and motor.
  - 4) Remove the hydraulic SUPPLY line from the equipment.
  - 5) Repeatedly actuate the remaining control valve levers IN BOTH DIRECTIONS to dissipate any residual pressure in the remainder of the hydraulic control system.
  - 7) Disconnect the hydraulic RETURN line from the equipment.
  - 8) Disconnect remaining hoses such as case drains, or lines connected to the turns counter.



**HYDRAULIC PRESSURES AS HIGH AS OPERATING PRESSURE MAY REMAIN TRAPPED IN SMALL AREAS OF THE EQUIPMENT. ENSURE ALL MAINTENANCE IS CARRIED OUT BY A QUALIFIED SERVICE TECHNICIAN, AND THAT ADEQUATE PERSONAL PROTECTIVE EQUIPMENT IS USED TO GUARD AGAINST PRESSURE INJURIES**

3.  Clean the exterior of the tool thoroughly, using either water (if using a pressure washer ensure a low-pressure wash wand is used), or an appropriate solvent-based grease-cutting cleaner such as Varsol. Ensure adequate containment is in place to prevent environmental contamination from residual hydraulic fluid, dirty grease, and cleaning agents.
4.  Remove the access panel on the side of the tong directly adjacent to the shifter mechanism.
5.  Clean the interior of the tong thoroughly, using either water (do not use a pressure washer), or an appropriate solvent-based grease-cutting cleaner such as Varsol. Ensure adequate containment is in place to prevent environmental contamination from residual hydraulic fluid, dirty grease, and cleaning agents. Make a note if any metal shavings or metal pieces are flushed out of the gear train cavity - if shavings or metal pieces are seen the tong must be overhauled before it is returned to service.
6.  Inspect all fasteners and fastener safety wires (if equipped). Replace any missing fasteners - use Grade 8 bolts only unless otherwise specified. Re-torque all external fasteners to SAE specifications.
7.  Repair or replace any damaged or missing external body parts, such as torque gauge mounts, hydraulic supports, safety door protectors, etc.
8.  Perform a visual inspection of all fasteners and protruding body pieces (example: hydraulic valve mounts, inlet & outlet line supports, tong legs, shifter handle pivot lugs). Tighten or replace loose or missing fasteners. McCoy recommends that damaged or missing body parts be repaired or replaced as soon as possible.
9.  Inspect tong for signs of premature wear, or moving parts that are rubbing (bare metal where there used to be paint is a good indication of wear).
10.  Inspect all paint - locations in which the paint has been damaged must be repaired prior to the tong being returned to service. Prepare areas to be painted to ensure they are free of grease, dirt, or solvent. Touch up using a solvent-based acrylic paint - "McCoy Grey" is paint color number RAL7015, "McCoy Yellow" (hazard areas) is RAL1007, and McCoy Green is RAL6029 (contact McCoy sales for paint number for custom paint applications). Allow sufficient time for paint to dry before proceeding.
11.  Inspect all external welds. Any weld that is cracked or separating must be repaired and repainted before returning the tong to service.

12.  Perform a visual inspection of all lifting points - if visible damage is seen, including cracks, broken lugs, distorted metal, etc. replace damaged part(s) before placing tong in service. Also inspect all chains, master links, and turnbuckles - again, if any damage is noted replace the damaged part(s) before placing the tong in service. Refer to Section 2A of the technical manual (Sling/Load Bearing Device Safety) for information on recommended testing and recertification. Please note that turnbuckles with part number 101-3086 (short turnbuckles) use a high-strength pin which must be supplied by McCoy.



**“SHORT” TURNBUCKLES HAVING PART NUMBER 101-3086 EMPLOY HIGH-STRENGTH PINS WHICH MUST BE SUPPLIED BY MCCOY.**

13.  Rotate the gear train by hand, and use a flashlight to perform a visual inspection of the gear train through the access panel and the opening of the rotary gear while the gear train is being rotated. If gear damage or chips of metal are seen, the tong should be removed from service and overhauled to avoid further damage. Replace access panel when inspection is complete.
14.  Inspect all jaws and dies in use for the maintenance interval. Inspect the jaw roller pins for signs of damage - replace pins if necessary. If the pins are welded in place, remove and quarantine the jaw until the weld is repaired. Ensure dies are secure in the jaw - replace worn dies if necessary. Ensure that the jaw rollers rotate freely.
15.  Inspect backing pin(s). If cracked, broken, or bent it (they) must be replaced.
16.  Inspect top and bottom brake band linings - replace if necessary. Unequal wear of the brake bands indicates that the brake band tension is not evenly adjusted. Refer to the maintenance section of the manual for instructions on properly adjusting brake bands.
17.  Inspect door springs. Ensure the springs retain sufficient strength to be able to assist the opening of the door, and to keep the door open. The springs should also help to “snap” the door shut.
18.  Inspect backup springs (if applicable). The rear extension springs should be equally extended, and the front leg springs should be equally compressed. Ensure that neither of the rear backup springs have been over-extended and lack sufficient tension to adequately support the backup. Ensure that neither of the front leg springs have been over-compressed, and still retain enough spring strength to support the front of the backup.
19.  Extend all hydraulic cylinders, and inspect cylinder rods for signs of mechanical damage, flaking, or rust. McCoy recommends that damaged cylinders be replaced prior to storage.
20.  Perform a visual inspection of all hydraulic lines. Replace flexible lines if they appear to be cracked, fatigued, or have visible signs of wear from contact with a rigid object. If your tong is equipped with rigid hydraulic lines, replace any line that is dented or appears to be stressed or cracked.
21.  Generously fill the gear train housing with grease through the access panel, and also through the opening in the rotary gear. Perform a full lubrication - refer to Maintenance section of manual to determine lubrication points.
22.  Ensure main supply and return connections to the tong are fully made up. Re-connect the remainder of the hydraulic lines, and, if applicable, the electrical line to the turns counter.



**FAILURE TO ENSURE THAT THE SELF-SEALING SUPPLY AND RETURN LINES ARE FULLY MADE UP MAY RESULT IN CATASTROPHIC EQUIPMENT FAILURE.**

If using a stand-alone power unit, start it now - refer to the power unit technical manual for startup procedures. Listen to power unit for a moment to see if there are any unusual mechanical sounds (rubbing, grinding, excessive pump noise). If using a diesel unit, allow sufficient time for the engine to reach operating temperature before increasing engine RPM. Once engine is warm, gradually increase engine RPM until operating speed is reached.

23.  Ensure that supply pressure is at or above the tong’s specified operating pressure, and that the return pressure is less than 350 psi.
24.  Perform a visual inspection of pressurized hydraulic lines. If any hydraulic fittings or hoses are leaking they must be repaired or replaced before proceeding.
25.  Rotate tong for one minute, stop, and reverse the direction of rotation for another minute, ending with the opening of the rotary gear facing the gear train. De-energize the power unit, and perform another generous lubrication of the gear train, including the gear housing.
26.  Energize power unit. Rotate tong for one minute, stop, and reverse the direction of rotation for another minute, ending with the opening of the rotary gear facing the gear train.
27.  De-energize the power unit, and perform a third generous lubrication of the gear train, including the gear housing.

28.  Re-energize power unit and extend all hydraulic cylinders. Inspect cylinder rods for signs of mechanical damage, flaking, or rust. McCoy recommends that damaged cylinders be replaced.
29.  Rotate tong in low gear for 5 minutes while monitoring pressurized seals and hydraulic lines. If a seal, line, or fitting begins to leak while tong is rotating, it must be replaced before the equipment is returned to service.
30.  Rotate tong in high gear for 5 minutes while monitoring temperature of top and bottom bearing caps. If the bearing caps are hot to the touch (higher than approximately 50°C) replace the applicable bearings. Likewise if the tong is making unusual noises check for damaged bearings (see Maintenance Manual for all bearing locations).
31.  Install load cell. If using a tension load cell, perform a visual inspection and replace any cracked, broken, or distorted components including links and chains. If using a compression load cell, replace any component that has been crushed or otherwise distorted through compression.
32.  If applicable, inspect the load cell anchor pins (tension load cell only). Replace the anchor pins if cracking or metal distortion is seen.
33.  If applicable, the weld securing the single load cell anchor to the bridge bar main plate must be inspected (compression load cell only). If the integrity of the weld has been compromised, the tong must be removed from service until the weld is repaired. The load cell beam will need to be disconnected and removed so the weld is visible. Before re-installing the beam, liberally grease the anchor pin before reinserting into the load cell beam.
34.  Inspect load cell for damage or signs of stress. Check oil level in load cell and fill if necessary (refer to technical manual Section 7 or Section 8).
35.  While rotating the cage plate, ensure that the jaws properly cam. If the jaws do not cam properly, the brake bands need to be tightened. Incrementally adjust both the top and bottom brake bands EQUALLY until proper cam action is achieved. Refer to the maintenance section of the manual for instructions on properly adjusting brake bands.
36.  Perform a full functional test of the tong including, if applicable, backup components, lift cylinder, and float frame components. Report and correct any hydraulic leaks from the hydraulic valve bank, or from any hydraulic cylinders that are used.
37.  Test safety door feature (if equipped). Begin rotating the tong at low speed, and open the tong door(s). If rotation does not immediately stop, this is an indication that the safety door mechanism is not operating correctly and the tong must be removed from service until the mechanism is repaired. Repeat the test while operating the tong in the opposite direction. If the safety door is operating correctly, cage plate rotation will not be inhibited once the door is closed and latched.



**NEVER OPERATE YOUR EQUIPMENT WITH A BYPASSED OR MALFUNCTIONING SAFETY DOOR**

38.  McCoy recommends that an anti-corrosive agent such as Tectyl® 506 be applied to all external unpainted surfaces (and chain slings) EXCEPT cylinder rods, jaw rollers, and rotary gear camming surfaces. Refer to manufacturer data sheets for proper application and safety information.

**Once all of the above maintenance checklist items have been satisfactorily completed the tool may be returned to service.**

**3.L TUBULAR CONNECTION EQUIPMENT DE-COMMISSIONING & SHIPPING PROCEDURE**

Perform the following decommissioning procedures when removing tubular connection equipment from service, with the intent of short to long-term storage. These procedures are essential for ensuring proper protection of the equipment from environmental attack, and to aid in the quick turnaround when returning the equipment to service.

Store all o-rings, seals, packings, gaskets, etc. in strong moisture proof, airtight containers. Ensure that these items are not crushed, nicked, or otherwise damaged.

Do not perform any further actions or maintenance while the tong is connected to any hydraulic power supply. McCoy Global recommends that all hydraulic lines are fully disconnected, and residual hydraulic pressure is bled off. Ensure adequate containment is in place to prevent environmental contamination from residual hydraulic fluid.



**IN ORDER TO MAINTAIN THE INTEGRITY OF INSTALLED SEALS, MCCOY RECOMMENDS THAT THE MAXIMUM STORAGE INTERVAL NOT EXCEED ONE YEAR. AT LEAST ONCE PER YEAR ALL TUBULAR CONNECTION IN LONG-TERM STORAGE SHOULD BE RECOMMISSIONED AS PER SECTION 3.M. IF FURTHER STORAGE IS REQUIRED, THE EQUIPMENT SHOULD THEN BE PUT THROUGH ANOTHER DE-COMMISSIONING PROCEDURE.**

**Depressurization Procedure In Preparation For Storage:**

- 1) Rotate the tong so that the opening in the rotary gear faces the gear train (towards the rear of the tong). Ensure tong and backup doors (if equipped) are closed. Fully extend the lift cylinder (if equipped). If mounted in a frame, retract the float cylinders (if equipped).
- 2) De-energize the power unit.
- 3) Repeatedly actuate the tong motor control valve lever IN BOTH DIRECTIONS to dissipate any residual pressure in the valve and motor.
- 4) Remove the hydraulic SUPPLY line from the equipment.
- 5) Repeatedly actuate the remaining control valve levers IN BOTH DIRECTIONS to dissipate any residual pressure in the remainder of the hydraulic control system.
- 7) Disconnect the hydraulic RETURN line from the equipment.
- 8) Disconnect remaining hoses such as case drains, or lines connected to the turns counter.



**HYDRAULIC PRESSURES AS HIGH AS OPERATING PRESSURE MAY REMAIN TRAPPED IN SMALL AREAS OF THE EQUIPMENT. ENSURE ALL MAINTENANCE IS CARRIED OUT BY A QUALIFIED SERVICE TECHNICIAN, AND THAT ADEQUATE PERSONAL PROTECTIVE EQUIPMENT IS USED TO GUARD AGAINST PRESSURE-INDUCED INJURIES**

1.  Perform an initial wash of the tool in order to remove the majority of dirt and grease build-up. Ensure adequate containment is in place to prevent environmental contamination from residual hydraulic fluid and dirty grease.
2.  Remove the access panel on the side of the tong directly adjacent to the shifter mechanism.
3.  Clean the interior of the tong thoroughly, using either water (do not use a pressure washer), or an appropriate solvent-based grease-cutting cleaner such as Varsol. Ensure adequate containment is in place to prevent environmental contamination from residual hydraulic fluid, dirty grease, and cleaning agents. Make a note if any metal shavings or metal pieces are flushed out of the gear train cavity - if shavings or metal pieces are seen the tong must be overhauled before it is returned to service.
4.  Clean the exterior of the tool thoroughly, using either water (do not use a pressure washer), or an appropriate solvent-based grease-cutting cleaner such as Varsol. Ensure adequate containment is in place to prevent environmental contamination from residual hydraulic fluid, dirty grease, and cleaning agents.
5.  Inspect all fasteners and fastener safety wires. Replace any missing fasteners - use Grade 8 bolts only. Re-torque all external fasteners to SAE specifications.
6.  Inspect backing pin(s). If cracked, broken, or bent it (they) must be replaced.
7.  Repair or replace any damaged or missing external body parts, such as torque gauge mounts, hydraulic supports, safety door protectors, etc.
8.  Inspect all paint - locations in which the paint has been damaged must be repaired prior to storage. Prepare areas to be painted to ensure they are free of grease, dirt, or solvent. Touch up using a solvent-based acrylic paint - "McCoy Grey" is paint number RAL7015. Allow sufficient time for paint to dry before proceeding.
9.  Perform a liberal lubrication of the equipment - refer to Maintenance section of manual to determine lubrication points. Generously fill the gear train housing with grease through the access panel, and also through the opening in the rotary gear.
10.  Connect the equipment to a hydraulic power unit. Ensure all lines are fully made up to prevent equipment damage from excessive back pressure. Do not neglect to connect the motor drain.

11.  Energize power unit.
12.  Rotate tong for one minute, stop, and reverse the direction of rotation for another minute, ending with the opening of the rotary gear facing the gear train. De-energize the power unit, and perform another generous lubrication of the gear train, including the gear housing.
13.  Energize power unit. Rotate tong for one minute, stop, and reverse the direction of rotation for another minute, ending with the opening of the rotary gear facing the gear train.
14.  De-energize the power unit, and perform a third generous lubrication of the gear train, including the gear housing.
15.  Energize power unit, and rotate the tong for a final time, one minute in one direction, stop, and reverse the direction of rotation for another minute, this time ending with the rotary gear in the "open throat" position.
16.  Extend all hydraulic cylinders, and inspect cylinder rods for signs of mechanical damage, flaking, or rust. McCoy recommends that damaged cylinders be replaced prior to storage.
17.  If you are using a frame-mounted tool, the tong must be lowered onto the backup in order to remove the risk of sudden and catastrophic movement when pressure is removed from the float cylinders. Cover the top of the backup with protective cloth to protect the paint on the backup. Place two wooden beams across the top of the tong, ensuring that the beams have a minimum size of 4" x 4" x the width of the tong. Cover the tops of the wooden beams with more protective cloth to prevent paint damage to the tong. When lowering the tong onto the beams, ensure that the beams come into flat contact with the bottom of the tong, away from bearing caps, brake bands, or other protrusions on the bottom of the tong. Ensure that the tong hanger chains are loose, but not dangling into contact with the hangers or top plate of the tong.

**DEPRESSURIZATION PROCEDURE FOR STORAGE:**

- 1) Rotate the tong to the "open throat" position.
  - 2) Exercise each hydraulic cylinder several times - open the tong and backup doors (if equipped), retract and extend the remote backing pin ramp (if equipped), retract and extend the float cylinders. Leave all cylinders except for the door cylinders in their fully retracted position. The general idea is to have as little of the chrome cylinder rods exposed as possible.
  - 3) De-energize the power unit.
  - 4) Repeatedly actuate the tong motor control valve lever IN BOTH DIRECTIONS to dissipate any residual pressure in the valve and motor.
  - 5) Remove the hydraulic SUPPLY line from the equipment.
  - 6) Repeatedly actuate the remaining control valve levers IN BOTH DIRECTIONS to dissipate any residual pressure in the remainder of the hydraulic control system.
  - 7) Connect a low-pressure air supply line (10 PSI or less) to the hydraulic supply line, and force a small amount of the remaining hydraulic fluid from the valve assembly - this will allow for thermal expansion of the hydraulic fluid if the equipment is stored or transported in high ambient temperatures. Failure to do this may result in damaged or destroyed seals in the equipment.
  - 8) Disconnect the hydraulic RETURN line from the equipment.
  - 9) Disconnect remaining hoses such as case drains, or lines connected to the turns counter.
18.  If any hydraulic fittings or hoses are leaking they must be repaired or replaced before proceeding.
19.  Wipe all excess grease from outside of equipment. Replace the access door panel. Use a solvent-based cleaner on rags to wipe all external surfaces to remove residual grease or hydraulic fluid. Once the outside surfaces have been de-greased, wipe all external surfaces with clean water to remove residual solvent.
20.  McCoy recommends that chain slings be removed and stored separately. Rigid slings and other rigid suspension devices may remain in place.
21.  Apply grease or heavy oil to all exposed cylinder rods.
22.  McCoy recommends that an anti-corrosive agent such as Tectyl® 506 be applied to all external surfaces EXCEPT cylinder rods (including chain slings). Refer to manufacturer data sheets for proper application and safety information.



**DO NOT ALLOW ANTI-CORROSIVE AGENTS TO CONTACT CYLINDER RODS. CYLINDER ROD DAMAGE WILL OCCUR.**



23.  Allow the anti-corrosive coating ample time to dry - refer to manufacturer data sheets for drying times at room temperature.
24.  Wrap entire assembly in 100 gauge (1 mil) corrosion-inhibiting wrap, at least 3 layers thick. Attempt to ensure that the tool is well-sealed within the wrapping, including the bottom.

If possible, store in a sealed, climate controlled environment. If isolated storage is not available, McCoy recommends storing your wrapped equipment in a secure, out-of-the-way location, using silica gel desiccant to reduce the humidity within the wrapping. As a guideline, use 125 g. of desiccant for each cubic metre of space, or 3.5 g. per cubic foot.

#### CALCULATION OF REQUIRED DESICCANT

1. Calculate the trapped air volume by measuring the outside dimensions of the tool to be stored, and treat that as the volume to be stored. For example, the external dimensions of a KT20000 20" power tong are 80.25" x 50.5" x 28", which calculates to an approximate volume of 113500 in<sup>3</sup>, or 66 ft<sup>3</sup> (1.87 m<sup>3</sup>).
2. Multiply the calculated air volume, in cubic feet, by the recommended amount of desiccant per cubic foot. Carrying forth the example used in the previous step, the required desiccant charge would be 3.5 g. x 66 ft<sup>3</sup>, equaling 231 g. Several manufacturers offer silica gel desiccant in packaged quantities of 125 grams per bag, so two packages of desiccant would be required. Please keep in mind that this is a guideline only - more or less desiccant may be required in extreme environmental conditions.

For best corrosion resistance the equipment should be removed from storage and exercised on a regular basis, depending on the storage environment. McCoy recommends that for equipment stored in a salt-water maritime or exposed dusty environment, repeat steps 9 through 24 monthly. For equipment stored in isolated storage in a non-maritime environment, repeat steps 9 through 24 quarterly. Replace desiccant packs at this time - depleted desiccant packs may be treated as regular dunnage.

#### SHIPPING INSTRUCTIONS

The following procedure lists the steps to be followed to prepare your tong for shipping.

1. If not already done remove accessories (tong jaws, load cell, torque gauge, etc.) McCoy recommends wrapping these items in protective wrap and placing in a separate wooden crate.
2. Place the equipment on a sturdy pallet constructed of 4" x 4" cross-members and 2" x 4" flooring. McCoy recommends placing a 2" x 6" board across the width of the tong under the legs (see Illustration 3.M.1). Ensure the pallet is large enough to accommodate the wooden crate containing the tong accessories.

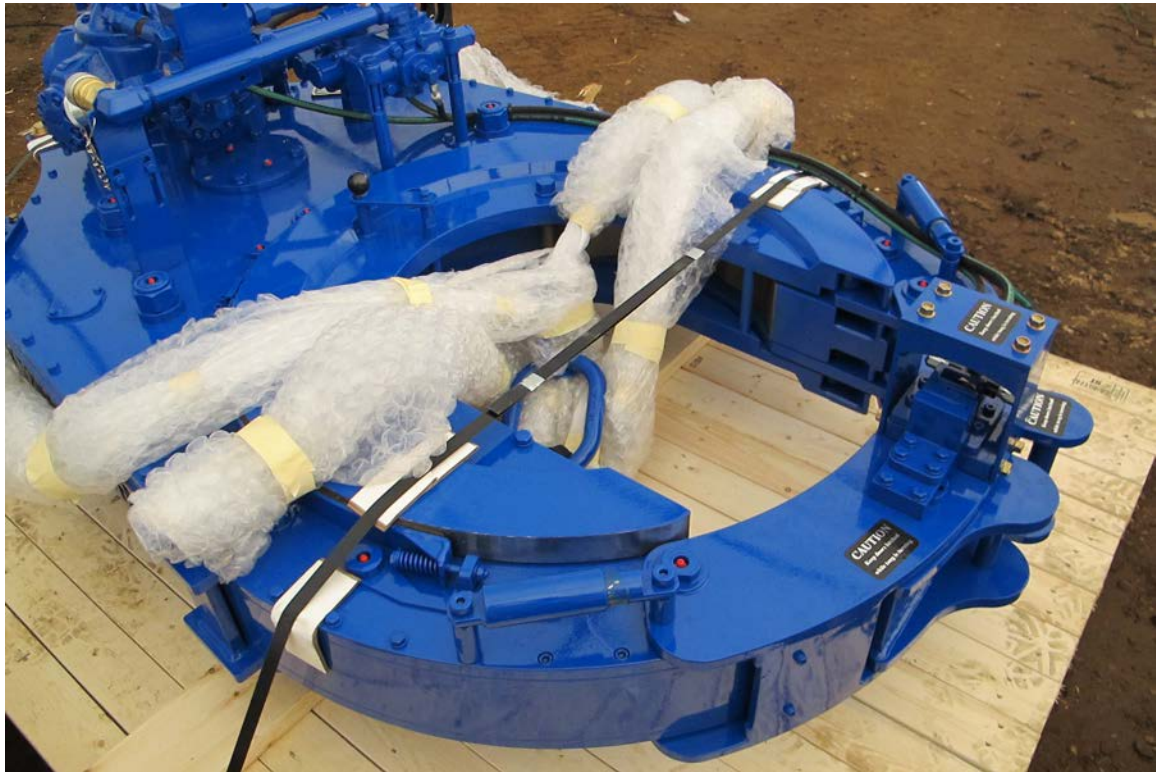


**Illustration 3.L.1: Shipping Instructions - Pallet**



**SHIPPING INSTRUCTIONS (CONTINUED):**

3. Use a crane to support the chain sling (if equipped). Wrap the chain sling with bubble wrap or another similar protective wrapping, and secure the wrapping with tape. Lower the wrapped chain sling so it sits inside the opening of the tong.



**Illustration 3.M.2: Shipping Instructions - Wrapping Chain Sling & Strapping To Pallet**

4. Securely strap the equipment in place using metal strapping (see Illustration 3.L.2). Place strapping as close to the cross-members under the equipment legs as possible, and use caution not to entrap any flexible hydraulic hoses beneath the strapping (guide strapping through beneath the hydraulic hoses). Use the following guidelines to determine the strapping requirements:

Assemblies weighing 1000 lbs. (454 kg.) or less:

3/4" x 0.029" metal strapping, 3320 lbs. (1509 kg.) tensile strength  
Minimum two straps

Assemblies weighing more than 1000 lbs. (454 kg.) or less:

1-1/4" x 0.031" metal strapping, 5500 lbs. (2500 kg.) tensile strength  
Minimum two straps for assemblies weighing less than 5000 lbs. (2273 kg.)  
Minimum three straps for assemblies weighing more than 5000 lbs. (2273 kg.)

Before tightening strapping, place strapping protectors wherever the metal strapping comes into contact with the equipment.

Place the wooden crate containing the tong accessories on the crate next to the equipment. Strap the crate to the pallet using 3/4" x 0.029" metal strapping. If it is not practical to place larger loose items in a wooden crate, ensure they are also securely strapped to the pallet using 3/4" x 0.029" metal strapping.

5. Use a large polyethylene shipping bag (sometimes called a pallet cover) to completely enclose the equipment. Seal polyethylene bag to the pallet using 1 mil polyethylene wrap. Use the wrap to conform the plastic cover to the general shape of the equipment, but do not wrap so tight that sharp edges on the equipment perforate the cover.
6. McCoy recommends enclosing the equipment in a sturdy shipping crate which is securely fastened to the pallet.

## 3.M TUBULAR CONNECTION EQUIPMENT RE-COMMISSIONING PROCEDURE

Perform the following recommissioning procedures when removing tubular connection equipment from short or long-term storage back into regular service. These procedures are essential for ensuring proper equipment preparation and operation. The following procedures also assume that the decommissioning and storage procedures recommended by McCoy Global have been strictly observed.

1.  Remove all protective plastic wrapping. If there are desiccant packs with the assembly, they may be disposed of with the regular garbage.
2.  Remove the access panel on the side of the tong directly adjacent to the shifter mechanism.
3.  Wipe excess grease or heavy oil from exposed cylinder rods.
4.  If applicable, re-connect chain sling to lifting lugs. Perform a visual inspection of all lifting points - if visible damage is seen, including cracks, broken lugs, distorted metal, etc. replace damaged part(s) before placing tong in service. Also inspect all chains, master links, and turnbuckles - again, if any damage is noted replace the damaged part(s) before placing the tong in service. If your company requires yearly certification of lifting equipment, ensure that the most recent test date falls within the past year. Perform recertification if necessary.
5.  Perform a liberal lubrication of the equipment - refer to Maintenance section of manual to determine lubrication points. Generously fill the gear train housing with grease through the access panel, and also through the opening in the rotary gear.
6.  Connect the equipment to a hydraulic power unit. Ensure all lines are fully made up to prevent equipment damage from excessive back pressure. Do not neglect to connect the motor drain.



**FAILURE TO ENSURE THAT THE SELF-SEALING SUPPLY AND RETURN LINES ARE FULLY MADE UP MAY RESULT IN CATASTROPHIC EQUIPMENT FAILURE.**

7.  Energize power unit.
8.  Ensure that supply pressure is at or above the tong's specified operating pressure, and that the return pressure is less than 350 psi.
9.  Perform a thorough inspection of pressurized hydraulic lines and fittings. Any leaking hydraulic fluid lines or fittings must be replaced before the equipment is returned to service.
10.  Perform a thorough inspection of all seals. Any seal that is leaking or "weeping" must be replaced before the equipment is returned to service.
11.  Rotate tong in low gear for 5 minutes while monitoring pressurized seals and hydraulic lines. If a seal, line, or fitting begins to leak while tong is rotating, it must be replaced before the equipment is returned to service. Finish this step with the rotary gear opening facing the gear train. De-energize the power unit.
12.  Inspect all flexible hydraulic lines for signs of wear, blistering, or any other signs of potential failure - replace if signs of potential failure are identified.
13.  Inspect the gear train housing. If the amount of grease is inadequate, liberally grease the gear train through the access panel, and through the opening in the rotary gear.  
Inspect top and bottom brake band linings - replace if necessary. Unequal wear of the brake bands indicates that the brake band tension is not evenly adjusted. Refer to the maintenance section of the manual for instructions on properly adjusting brake bands. Ensure that all grease is wiped from brake band linings and the parts of the cage plates that come into contact with the brake band linings
14.
15.  Re-install access panel. Install a set of pre-inspected jaws that are the correct size for the pipe or casing being run.
16.  Install load cell. If using a tension load cell, perform a visual inspection and replace any cracked, broken, or distorted components including links and chains. If using a compression load cell, replace any component that has been crushed or otherwise distorted through compression.
17.  If applicable, inspect the load cell anchor pins (tension load cell only). Replace the anchor pins if cracking or metal distortion is seen.
18.  If applicable, the weld securing the single load cell anchor to the bridge bar main plate must be inspected (compression load cell only). If the integrity of the weld has been compromised, the tong must be removed from service until the weld is repaired. The load cell beam will need to be disconnected and removed so the weld is visible. Before re-installing the beam, liberally grease the anchor pin before reinserting into the load cell beam.
19.  Re-energize power unit.

20.  Perform a full functional test of the equipment including, if applicable, backup components and float frame components. Report and correct any hydraulic leaks from the hydraulic valve bank, or from any hydraulic cylinders that are used.
21.  If using a frame-mounted tong and backup system, raise the tong off the beams that it is resting upon. Remove the beams and protective cloths - inspect the paint on top of the backup and the bottom of the tong to ensure it has not been damaged by the beam.
22.  Test safety door feature (if equipped). Open the tong door(s), and attempt to rotate the cage plate at low speed (low gear) in both directions (makeup and breakout). If cage plate begins rotating, the safety door mechanism is not functional, and the tong must be removed from service until the safety door mechanism can be repaired. If the safety door is operating correctly, cage plate rotation will not be inhibited once the door is closed and latched.

**NEVER OPERATE YOUR EQUIPMENT WITH A BYPASSED OR MALFUNCTIONING SAFETY DOOR**

23.  While rotating the cage plate, ensure that the jaws properly cam. If the jaws do not cam properly, the brake bands need to be tightened. Incrementally adjust both the top and bottom brake bands EQUALLY until proper cam action is achieved.
24.  When all of the previous steps are completed, you may return your re-commissioned equipment to service.



**This page intentionally  
left blank**



## SECTION 4: TROUBLESHOOTING



**This page intentionally  
left blank**



Adequate maintenance and proper fluid selection is essential for minimizing hydraulic-related failures. All troubleshooting must be performed by a technician trained in hydraulic systems, and familiar with the equipment design, assembly and operation.

The following troubleshooting instructions are intended to be guidelines only. Any faults not solved through the use of this guide should be referred to our engineering department for their evaluation and recommendations.

**4.A TONG WILL NOT DEVELOP SUFFICIENT TORQUE**

	POSSIBLE PROBLEM	SOLUTION(S)
1	Malfunctioning relief valve on tong hydraulic circuit	See Section 4.B, Relief Valve Troubleshooting
2	Directional valve is leaking	Check directional valve. Neutral position should return fluid directly to the reservoir. Replace or repair valve to ensure correct operation
3	Power unit is not producing adequate pressure	Troubleshoot power unit (see user's manual for your particular unit)
4	Poor hydraulic pressure at the tong despite adequate pressure at the power unit, or excessive back pressure in the return line.	Restrictions exist in line between power unit and tong. Inspect integrity of self-sealing couplings to ensure they are allowing full fluid flow. Check to ensure no other restrictions exist (contaminated catch screens or filters, for example)
5	Fluid viscosity is not appropriate (too high or too low)	Ensure hydraulic fluid being used is the viscosity recommended by McCoy Global. Power unit pump may not prime if fluid is too heavy, and the hydraulic system will overheat if fluid is too light. Replace with proper viscosity fluid Hydraulic fluid viscosity is affected by environmental conditions. Ensure the fluid being used is suitable for high or low temperatures. Replace with proper viscosity fluid for the operating conditions if necessary
6	Worn or damaged tong motor causing slippage	Replace or repair worn or damaged motor
7	Damaged bearings or gears causing excessive drag	Replace or repair worn or damaged gears or bearings
8	Jaws slipping on pipe	Ensure jaw dies are not worn to the point that they cannot grip. Ensure the correct sized jaws are in use
9	Torque gauge is indicating incorrectly	Incorrect gauge is being used. Ensure gauge is the proper range, and has been properly calibrated for the arm length of the equipment in use Gauge has been damaged. Check gauge operation and calibration on independent system Gauge has mistakenly been married to an incorrect load cell
10	Load cell is measuring incorrectly	Incorrect load cell is being used Air is trapped in torque measuring circuit (load cell, hydraulic line, or gauge. Refer to torque measurement troubleshooting in Section 6 of this manual Load cell has been damaged. Replace load cell, or return to McCoy for repair and re-calibration



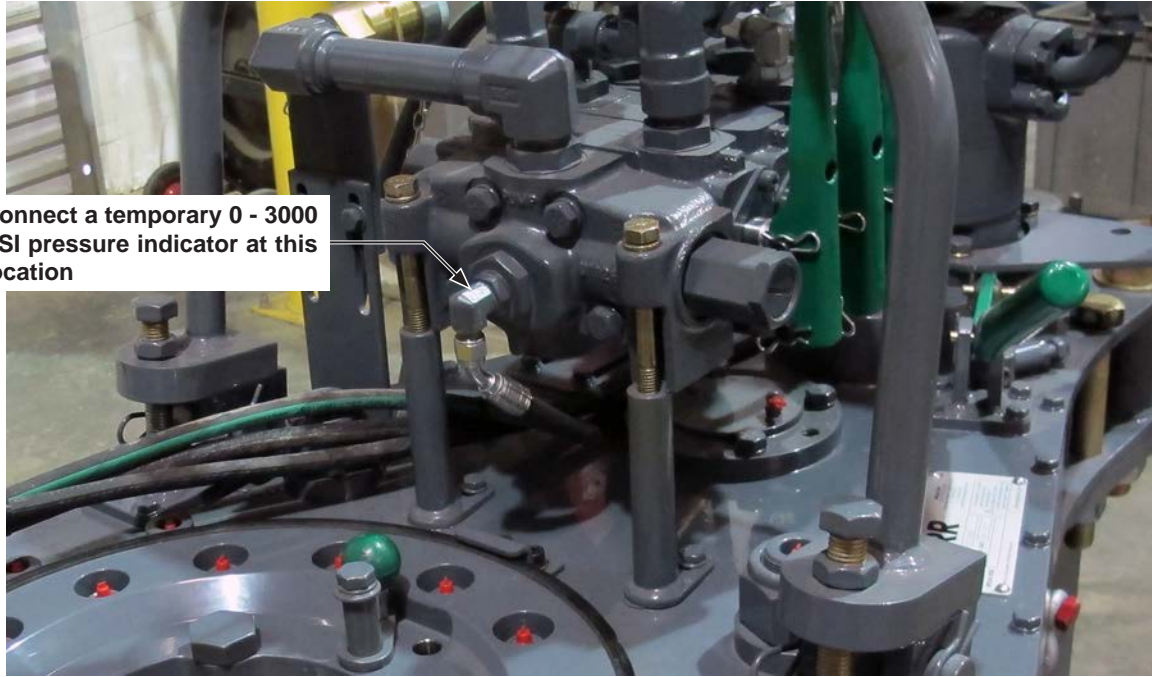
**MCCOY GLOBAL GUARANTEES CALIBRATION OF A LOAD CELL/TORQUE GAUGE ASSEMBLY FOR A PERIOD OF ONE YEAR. MCCOY SUGGESTS THAT THE LOAD CELL/TORQUE GAUGE ASSEMBLY BE RETURNED TO THE FACTORY FOR RE-CALIBRATION ON A YEARLY BASIS.**

	POSSIBLE PROBLEM	SOLUTION(S)
11	Incorrect motor speed selected (applies to 2-speed motors only)	Maximum torque can only be developed when LOW motor speed (maximum hydraulic displacement) is selected.
12	Incorrect tong gear selected	Maximum torque can only be developed when LOW motor gear is selected

4.B RELIEF VALVE IS INCORRECTLY SET OR NOT FUNCTIONING

	POSSIBLE PROBLEM	SOLUTION(S)
1	Relief pressure set too low, resulting in insufficient tong torque Relief pressure set too high, resulting in crushed pipe or gear train failure	Adjust setting (See following procedure):

- a. If your tong is equipped with a system pressure indicator proceed to step "f". If your tong does not have a system pressure indicator, a temporary 0 - 3000 PSI indicator must be installed on the hydraulic inlet.
- b. Isolate your tong from hydraulic power, and depressurize following the procedure in section 3.D.
- c. Tee in a temporary indicator at the safety door supply pressure port. Ensure all hydraulic connections are performed by a qualified hydraulic technician.



**Illustration 4.B.1: Relief Valve Troubleshooting - Temporary Gauge Installation**

- d. Re-establish hydraulic power to your tong. Ensure that no equipment functions are active.
- e. Loosen the locking nut on the pressure relief valve.
- f. Open the tong door to activate the safety door system and inhibit tong rotation.
- g. Activate motor control valve. Observe the pressure displayed on the pressure indicator. Adjust the relief valve until the pressure indicated is at the maximum system pressure specified on the specifications page (maximum system pressure is the pressure at which your tong achieves its specified torque).



**DO NOT ADJUST PRESSURE RELIEF TO A SETTING THAT ALLOWS HIGHER THAN MAXIMUM SYSTEM PRESSURE. DOING SO CREATES A POTENTIAL FOR SERIOUS INJURY OR DEATH, AND MAY CAUSE CATASTROPHIC EQUIPMENT FAILURE.**

- h. Release the motor control valve and tighten the locking nut on the pressure relief valve.
- i. Isolate your tong from hydraulic power, and depressurize following the procedure in section 3.D.
- j. Close the tong door, and remove the temporary pressure indicator. Restore the safety door pressure supply line to factory specifications. Verify that safety door is operating correctly (see section 2.H.5.k).

Continued on next page...

4.B RELIEF VALVE IS INCORRECTLY SET OR NOT FUNCTIONING (CONTINUED):

	POSSIBLE PROBLEM	SOLUTION(S)
2	Relief cannot be adjusted to maximum system pressure (high fluid bypass results in low system pressure)	Debris on valve seat
		Valve spring is broken
		Valve spring has lost spring force due to continuous tension

PROCEDURE:

- a. Isolate your tong from hydraulic power, and depressurize following the procedure in section 3.D
- b. Loosen the locking nut on the pressure relief valve.
- c. Use a large flat-head screwdriver to completely un-thread the poppet and spring from the relief assembly.
- d. Inspect the relief valve spring, poppet, and valve seat.
- e. If no debris is found in relief valve and if seat and poppet are undamaged, replace relief valve spring.
- f. Reassemble relief valve.
- g. Relief valve must be re-set to allow maximum system pressure. Follow the procedure in Step 1 of this section to properly adjust relief valve.
- h. If maximum system pressure still cannot be reached, replace the entire relief valve assembly.

**4.C SAFETY DOOR DOES NOT OPERATE OR IS MALFUNCTIONING**

	<b>POSSIBLE PROBLEM</b>	<b>SOLUTION(S)</b>
<b>1</b>	Safety door switch requires adjustment.	Adjust switch as per section 3.F.5
<b>2</b>	Safety door switch has failed	Test safety door switch for proper function and replace if necessary
<b>3</b>	Contamination in hydraulic lines	Ensure all three flexible hydraulic lines to safety door switch are free-flowing
<b>4</b>	Pilot-to-open valve in safety door valve block is malfunctioning.	Remove each valve. Inspect seats and springs. Replace valve(s) if damage is seen on valve seats, or if spring appears to be damaged or broken.

4.D TONG RUNNING TOO SLOWLY

	POSSIBLE PROBLEM	SOLUTION(S)
1	Obstruction in tong hydraulic circuit preventing adequate flow	Inspect self-sealing couplings to ensure they are properly engaged The main hydraulic lines (supply and discharge) to the tong are obstructed. Remove and clean if required
2	Power unit is not producing adequate flow or pressure	Troubleshoot power unit (see user's manual for your particular unit)
3	Tong motor is excessively worn and is leaking hydraulic fluid past the vanes	Replace motor, or rebuild as per Section 7 of this manual
4	Bearings in gear train and rotary section are excessively worn	Overhaul tong. See Section 3 of this manual for tong overhaul procedures
5	Shifter has malfunctioned and the tong is not shifting to high gear	Inspect and repair shift mechanism as necessary
6	Hydraulic fluid viscosity too high	Ensure hydraulic fluid meets McCoy Global specifications
		Ensure hydraulic fluid is appropriate for climatic conditions, especially during cold-weather operation
7	By-pass valve not functioning	Check and repair

**4.E FAILURE OF JAWS TO GRIP PIPE**

	<b>POSSIBLE PROBLEM</b>	<b>SOLUTION(S)</b>
1	Dies have become too dull to provide adequate grip	Replace dies
2	Incorrect jaws are being used	Double-check jaw size to ensure they are rated for the diameter of pipe or casing being run
3	Incorrect dies are being used	Ensure dies loaded in the jaws are appropriate for the type of pipe or casing being run
4	Brake band(s) is (are) insufficiently adjusted, not allowing jaws to cam properly	Adjust brake bands to give proper resistance to cage plates
5	Jaw roller broken or worn	Remove jaw assembly and inspect. Replace rollers that are visibly "flat-spotted" or otherwise damaged



## 4.F FAILURE OR DIFFICULTY OF TONG TO SHIFT

	POSSIBLE PROBLEM	SOLUTION(S)
1	Bent or broken shifter yoke	Inspect components through inspection door. Replace shifter yoke if necessary.
2	Bent or broken shifter shaft	Replace
3	Locking nuts on shifting shaft have loosened and position of yoke has changed	Reposition yoke and re-tighten locking nuts
4	Shifting yoke has come loose from shifting shaft	Inspect yoke and inspect for damage. If free of damage, replace on shaft and tighten locking nuts
5	Shifting mechanism requires adjustment	Adjust shifting mechanism - see Section 3.F.3

**4.G GENERAL COMMENTS**

The following factors generally contribute to poor hydraulic operation and premature wear of equipment:

1. Contaminated hydraulic fluid due to overuse, overheating, or inadequate fluid filtration.
2. Unsuitable hydraulic fluid, especially in extreme climatic conditions.
3. Defective packing or seals in components of the hydraulic system.
4. Poor or incomplete hydraulic system training. Users must be fully qualified to operate the equipment, and have complete understanding of the hydraulic system.

If your hydraulic troubleshooting procedures involve flow and pressure tests at the power unit, McCoy Global recommends construction of a test rig that can easily be connected to the main suction and discharge ports of the power unit.



**SECTION 5: PARTS & ASSEMBLIES**

**CRITICAL SPARE PARTS**

The critical spare parts on page 5.2 list identifies those parts that, if missing or damaged, results in one of the following possibilities:

- the operator(s) is exposed to a hazard while operating the equipment
- the equipment cannot be operated in a safe manner
- the equipment is inhibited from operating at all

McCoy recommends having the specified quantities of all critical spare parts on hand at all time. The parts indicated in **red** indicate essential health and safety items. Failure to replace damaged essential health and safety components will present immediate danger to personnel. McCoy strongly recommends that the equipment is removed from service until the damaged or missing components can be replaced.

The quantities listed in the table on page 5.2 are **total** quantities that McCoy recommends having on hand at all times. See individual parts & assemblies pages to see the quantity of each part required for each assembly.

<b>MISC TONG &amp; BACKUP PARTS</b>		
<b>Description</b>	<b>Part Number</b>	<b>Qty. Required</b>
Clutch drive gear	101-5950	1
Gear key	101-5924	1
Shifting fork	101-6010	1
Shifting shaft	101-6009	1
Jaw pivot bolt	1393-28	2
Backing pin	1393-39	1
Guide ring	1393-23	1
Lined brake band weldment	101-5966	2
Latch claw	101-5982	2
Door latch spacer	101-5997	4
Latch spring (not shown)	AW12-19	2
Master link	02-9128	1
Rigid sling helix pin	1095-218	1
Rigid sling hanger pin	997-955	2
<b>FASTENERS &amp; FITTINGS</b>		
<b>Description</b>	<b>Part Number</b>	<b>Qty. Required</b>
3/8" UNC x 1" drilled hex socket cap screw (safety door)	02-E0249	2
1/4" UNC x 2" drilled cap screw (safety door)	101-6072	4
1/2" UNC x 2-1/2" drilled hex bolt (rigid sling)	101-6071	4
1/2" UNC x 1-1/2" drilled hex bolt (rigid sling)	101-6070	4
<b>HYDRAULIC COMPONENTS</b>		
<b>Description</b>	<b>Part Number</b>	<b>Qty. Required</b>
Relief cartridge (DVA35)	10-0010R	1
Relief cartridge (safety door)	08-1625	1
Safety door switch	02-E0190	1
Hydraulic hose - lift cylinder supply (if lift cylinder is installed)	02-0934H	1
High-visibility protective wrap, lift cylinder hose (if lift cylinder is installed)	02-E0203	1
Seal kit - hydraulic motor	87-7130	1
Seal kit - hydraulic valve	07-0004	1
<b>JAW COMPONENTS</b>		
<b>Description</b>	<b>Part Number</b>	<b>Qty. Required</b>
Jaw roller assembly (3-1/2" to 5-1/2")	1393-J-550-A	2
Jaw roller (6-5/8 through 13-5/8 & 14-3/8")	1393-JR-300	2
Jaw roller (14")	1393-JR-2000	2
Jaw pin	1393-JP	2
Standard 5" die insert	13-0008-500-0	48
3/8" UNC x 1/2" flange head machine screw	02-9292	4

**RECOMMENDED (ONE YEAR) SPARE PARTS**

McCoy suggests stocking the spare parts listed in the table on page 5.3. Even though these are not critical spares, stocking these components may significantly decrease repair time in the event of long lead times from the factory

The quantities listed in the table on page 5.3 are **total** quantities of each part that McCoy recommends stocking. See individual parts & assemblies pages to see the quantity of each part required for each assembly.

MISC TONG PARTS		
Description	Part Number	Qty. Recommended
Front cage plate spacer	101-3630	2
Shifter detent spring	997-0-64	2
Shifter detent ball	02-0018	2
Backing pin knob	02-0017	1
Backing pin retainer	1393-40	1
Motor gear	101-5951	1
Brake band spring	1404-29-04	2
Latch pin	101-5986	2
Door spring stop cylinder	1037-A4-144	1
BEARINGS & BUSHINGS		
Description	Part Number	Qty. Recommended
Pinion bearing	1393-93	2
Top clutch shaft bearing	02-E0236	1
Lower clutch bearing	1393-55	1
Lay gear bearing (x 2)	1393-55	2
Door latch bushing	101-4885	2
FASTENERS & FITTINGS		
Description	Part Number	Qty. Recommended
0.093" x 1-1/8" hitch pin	02-0274	2
3/8" x 1-1/2" clevis pin	09-7116	2
3/4" x 1" hex socket UNC shoulder bolt (brake band pivots)	09-0190	2
1/2" UNC x 8-1/2" brake band adjustment bolt	09-1200	1
3/4" UNC nylock nut (door latch shaft)	1429-39-02	2
3/4" narrow flat washer (door latch shaft)	09-5013	2
1/4" UNC x 1" hex cap screw (safety door adjustment screw)	09-1007	1
R-clip	02-0981	2
HYDRAULIC COMPONENTS		
Description	Part Number	Qty. Required
0 - 3000 PSI pressure gauge	02-0245	1
Motor seal kit	87-7130	1

**ITEMS ON THE CRITICAL SPARE PARTS LIST MARKED IN RED INDICATE ESSENTIAL HEALTH & SAFETY ITEMS. FAILURE TO REPLACE DAMAGED ESSENTIAL HEALTH & SAFETY ITEMS WILL PRESENT IMMEDIATE DANGER TO PERSONNEL OR EQUIPMENT. HAVE THESE ITEMS ON HAND AT ALL TIMES. STOP WORK AND QUARANTINE TONG UPON DISCOVERY OF DAMAGED OR DEFECTIVE HEALTH AND SAFETY COMPONENTS UNTIL PARTS CAN BE REPLACED.**

**PARTS REQUIRED FOR OVERHAUL**

McCoy recommends replacing all parts listed in the tables on pages 5.4 - 5.5 when overhauling your equipment.

The parts indicated in red indicate essential health and safety items. McCoy strongly recommends replacing these components when overhauling your equipment.

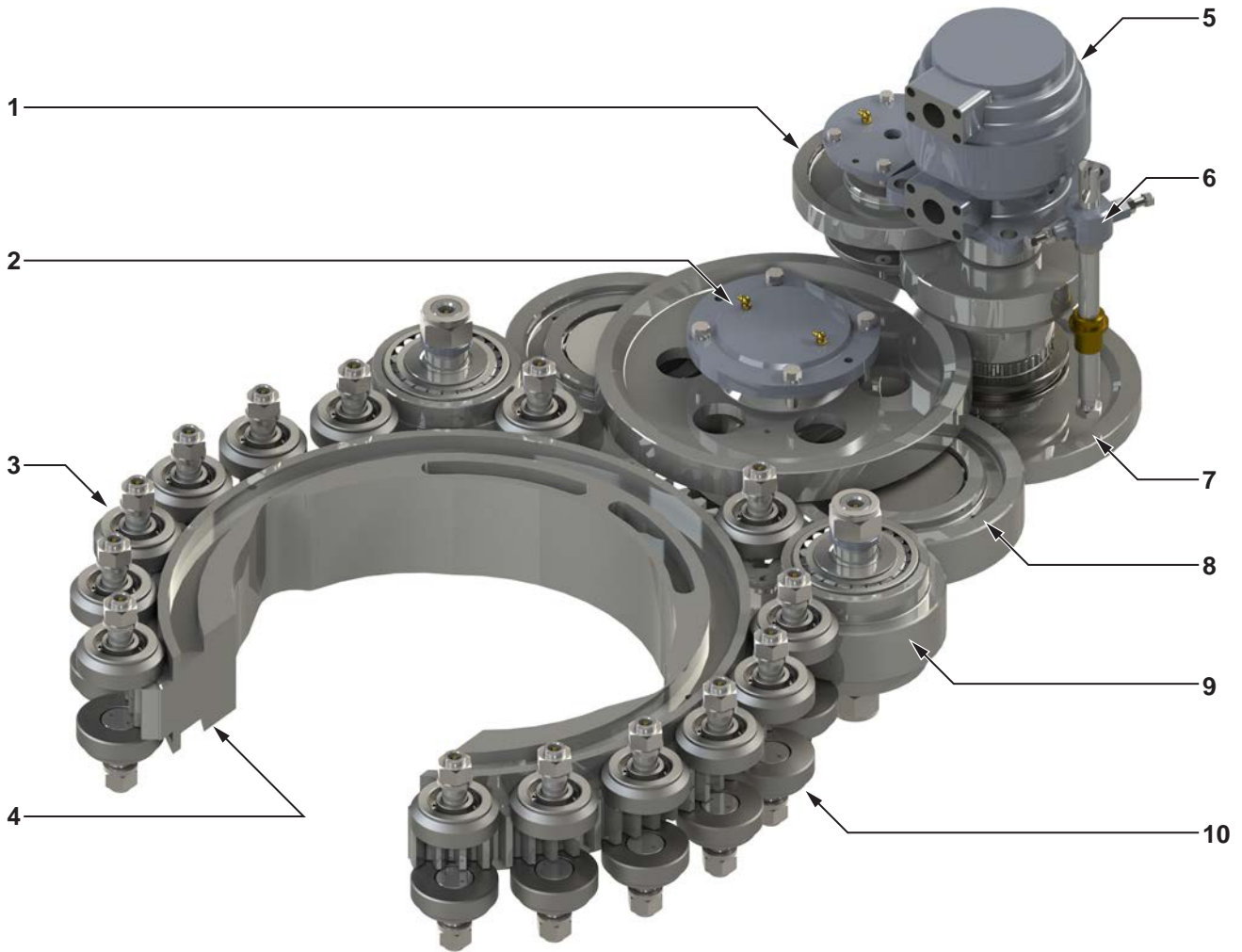
The quantities listed in the table on page 5.4 - 5.5 are **total** quantities of each part that McCoy recommends stocking for the purpose of overhauling your tong. See individual parts & assemblies pages to see the quantity of each part required for each assembly.

**ITEMS ON THE CRITICAL SPARE PARTS LIST MARKED IN RED INDICATE ESSENTIAL HEALTH & SAFETY ITEMS. MCCOY STRONGLY RECOMMENDS REPLACING ALL ESSENTIAL HEALTH & SAFETY ITEMS WHEN OVERHAULING YOUR EQUIPMENT.**

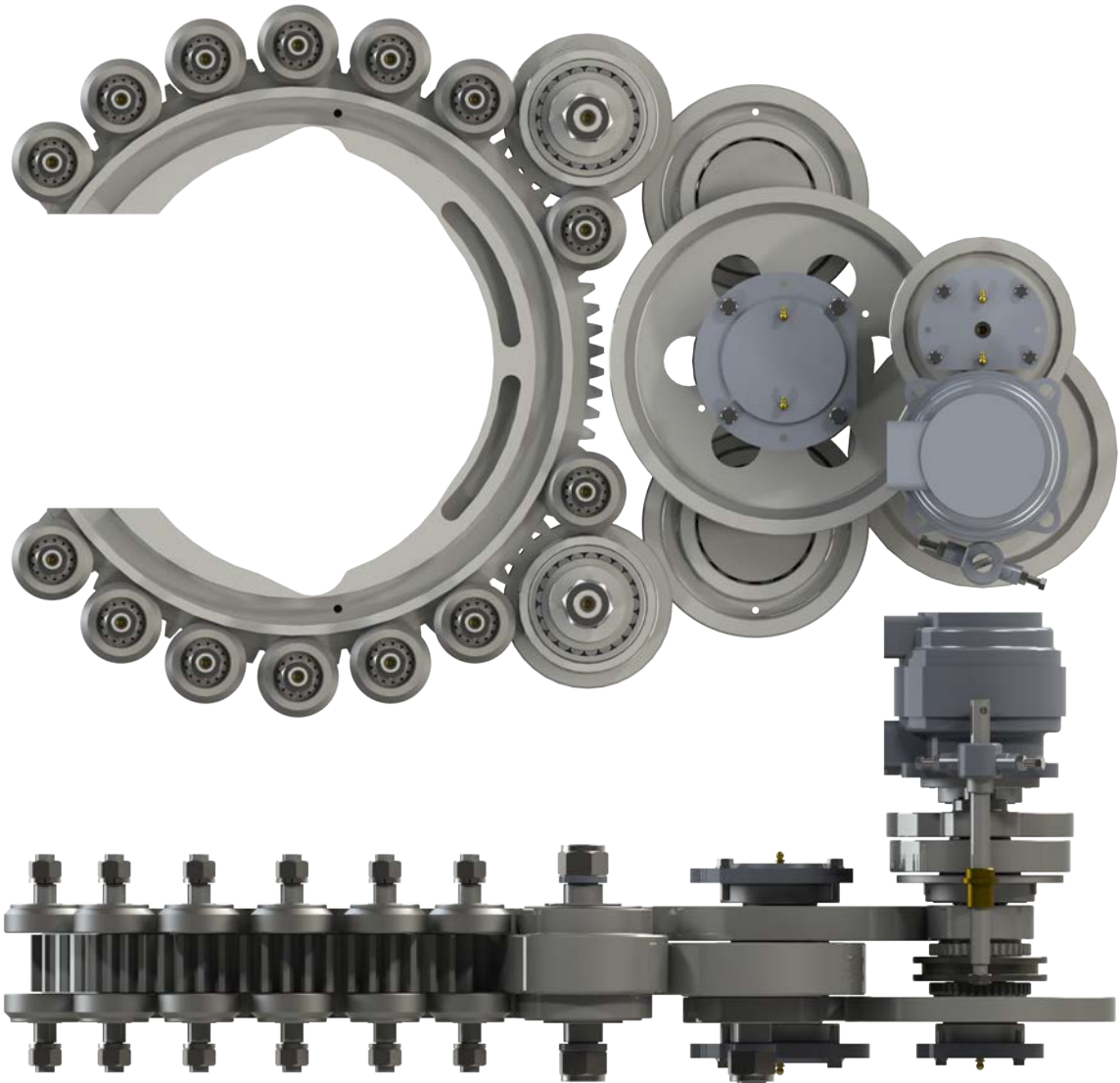
MISC TONG PARTS		
Description	Part Number	Qty. Required
Spacer (top support roller assemblies)	101-6207	14
Spacer (bottom support roller assemblies)	101-6206	14
Support roller cup (top assemblies)	101-6200	14
Support roller cup (bottom assemblies)	101-6199	14
Support roller half-shaft	101-6193	28
Pinion gear spacer	101-5929	1
High pinion gear	101-5928	1
Clutch drive gear	101-5950	1
Clutch drive gear key	101-5924	1
Top clutch gear spacer	101-5949	1
Low clutch gear	101-5921	1
Clutch shaft	101-5920	1
Shifting collar	1393-62	1
High clutch gear	101-5922	1
Lower clutch shaft spacer	101-5923	1
Lay gear	101-5917	1
Lay gear key	101-5918	1
Shifter detent spring	997-0-64	2
Shifter detent ball	02-0018	2
Shifting fork	101-6010	1
Shifting shaft	101-6009	1
Backing pin knob	02-0017	1
Backing pin retainer	1393-40	1
Backing pin	1393-39	1
Guide ring	1393-23	2
Rear cage plate bolt/spacer	1393-36	1
Jaw pivot bolt	1393-28	2
Front cage plate spacer	101-3630	2
Square 1/2" x 1/2" x 2 motor gear key	101-3596	1
Motor gear	101-5951	1
1/4" UNC x 3/8" set screw (motor gear)	09-0107	3
Brake band adjustment spring	1404-29-04	2
Lined brake band weldment	101-5966	4
Door latch claw	101-5982	2
Door latch pin	101-5986	2
Door latch spacer	101-5997	4
Door latch spring	AW12-19	2



MISC TONG PARTS (CONTINUED)		
Description	Part Number	Qty. Required
Door spring stop cylinder	1037-A4-144	1
Master lifting link	02-9128	1
Rigid sling helix pin	1095-218	1
Rigid sling hanger pin	997-955	1
BEARINGS & BUSHINGS		
Description	Part Number	Qty. Required
Support roller bearing	02-E0258	28
Rotary idler bearing	02-E0239	2
Pinion idler bearing	02-E0240	2
Pinion bearing	1393-93	2
Top clutch shaft bearing	02-E0236	1
Clutch gear needle bearing	1393-53	4
Lower clutch bearing	1393-55	1
Lay gear bearing	1393-55	2
Lower shifter bushing	1393-78	1
Door latch bushing	101-4885	2
Door bushing	101-5990	2
Door shoulder bushing	101-5987	2
Bottom door pivot bushing	101-5991	1
FASTENERS & FITTINGS		
Description	Part Number	Qty. Required
¼" UNF straight grease fitting	02-0070	30
⅜" NPT grease fitting	02-0005	16
⅜" NPT 90° grease fitting	02-0093	8
Retaining ring (top support roller assemblies)	02-E0259	14
Retaining ring (clutch shaft)	02-E0237	1
0.093" x 1-⅛" hitch pin (shifter)	02-0274	2
⅜" x 1-½" clevis pin (shifter)	09-7116	2
¾" x 1" hex socket UNC shoulder bolt (brake band pivot)	09-0190	4
¾" UNC nylock nut (door latch pins)	1429-39-02	2
¾" Narrow flat washer (door latch pins)	09-5013	2
⅜" UNC x 1" drilled hex socket cap screw	02-E0249	2
¼" UNC x 1" hex cap screw (safety door switch adjustment)	09-1007	1
¼" UNC x 2" drilled cap screw	101-6072	4
½" UNC x 2-½" drilled hex bolt (rigid sling hanger lug)	101-6071	4
½" UNC x 1-½" drilled hex bolt (rigid sling hanger lug)	101-6070	4
R-clip (rigid sling)	02-0981	5
HYDRAULIC COMPONENTS		
Description	Part Number	Qty. Required
Hydraulic motor seal kit	87-7130	1
Seal Kit - hydraulic valve	07-0004	2
Safety door switch	02-E0190	1
Hydraulic hose - lift cylinder supply (If lift cylinder is installed)	02-0934H	1
High-visibility protective wrap, lift cylinder hose (If lift cylinder is installed)	02-E0203	1

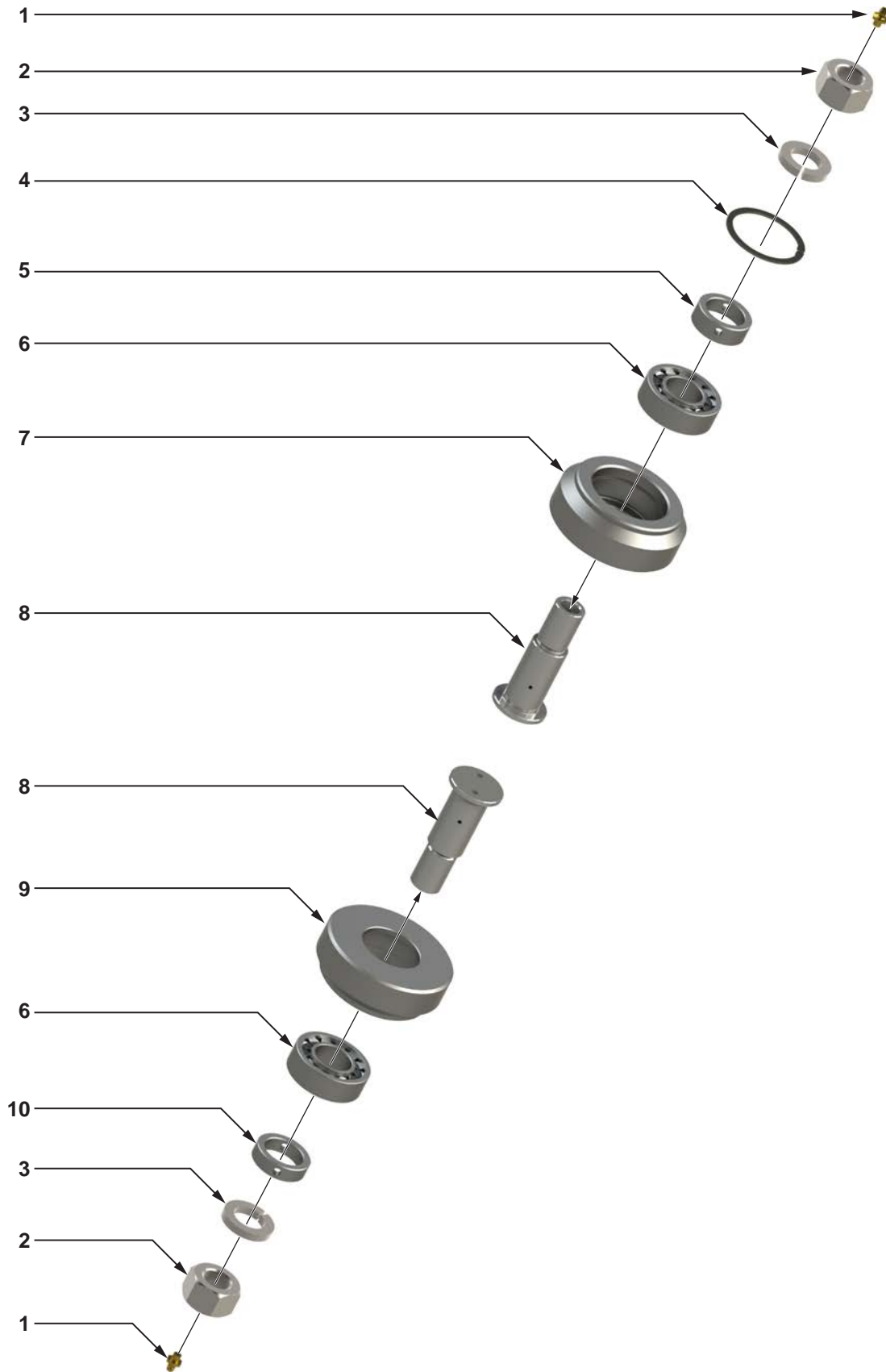


**Illustration 5.1: Gear Train ISO View**



**Illustration 5.2: Gear Train Top & Side View**

Item	Type	Description	Qty	Part Number
1	Assembly	Lay gear assembly (Pp. 5.18 - 5.19)	1	LGA-14-75K
2	Assembly	Pinion assembly (Pp. 5.14 - 5.15)	1	PA-14-75K
3	Assembly	Top support half-roller (Pp. 5.8 - 5.9)	14	101-5937
4	Part	Rotary gear	1	101-6204
5	Part	Hydraulic motor	1	87-0130
6	Assembly	Shifter (See Pp. 5.20 - 5.21)	1	
7	Assembly	Clutch assembly (Pp. 5.16 - 5.17)	1	CA-14-75K
8	Assembly	Pinion Idler assembly (Pp. 5.12-5.13)	2	PIA-14-75K
9	Assembly	Rotary Idler assembly (Pp. 5.10-5.11)	2	RIA-14-75K
10	Assembly	Bottom support half-roller (Pp. 5.6 - 5.7)	14	101-5938



**Illustration 5.3: Support Half-Rollers**

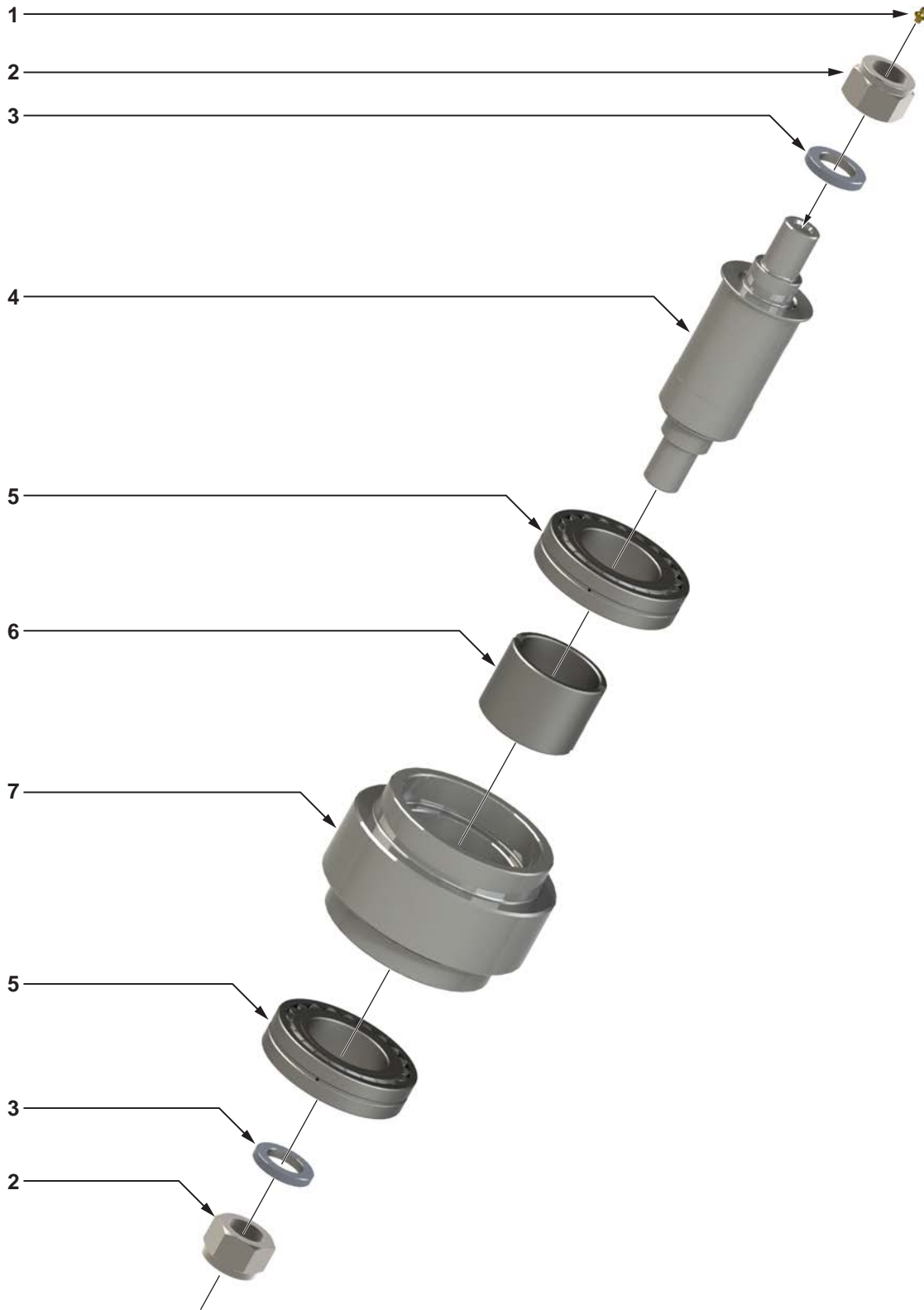


**Illustration 5.4: Support Half-Rollers**

Item	Type	Description	Qty	Part Number	Recommended Spares (Per Assembly)		
					Critical	One-Year	Overhaul
	Assembly	Top half-roller *	14	101-6191			
1	Part	¼" UNF straight grease fitting	1	02-0070			1
2	Part	1" UNC hex nut	1	09-5826			
3	Part	1" lock washer	1	09-5126			
4	Part	Retaining ring	1	02-E0259			1
5	Part	Spacer (top assemblies)	1	101-6207			1
6	Part	Bearing	1	02-E0258			1
7	Part	Roller cup (top assemblies)	1	101-6200			1
8	Part	Roller half-shaft	1	101-6193			1
	Assembly	Bottom half-roller *	14	101-6192			
9	Part	Roller cup (bottom assemblies)	1	101-6199			1
10	Part	Spacer (bottom assemblies)	1	101-6206			1

\* Does not include lock washer and hex nut

**Note that quantities are per single assembly**



**Illustration 5.5: Rotary Idler Exploded**





**Illustration 5.6: Rotary Idler Gear Assembly**

Item	Type	Description	Qty	Part Number	Recommended Spares (Per Assembly)		
					Critical	One-Year	Overhaul
1	Part	Grease fitting, 1/8" NPT	1	02-0005			1
2	Part	1-1/2" UNC nylock nut	2	09-5739			
3	Part	Idler pad	2	101-6029			
4	Part	Rotary idler shaft	1	101-5934			
5	Part	Idler bearing	2	02-E0239			2
6	Part	Internal idler gear spacer	1	101-5954			
7	Part	Rotary idler gear	1	101-5933			

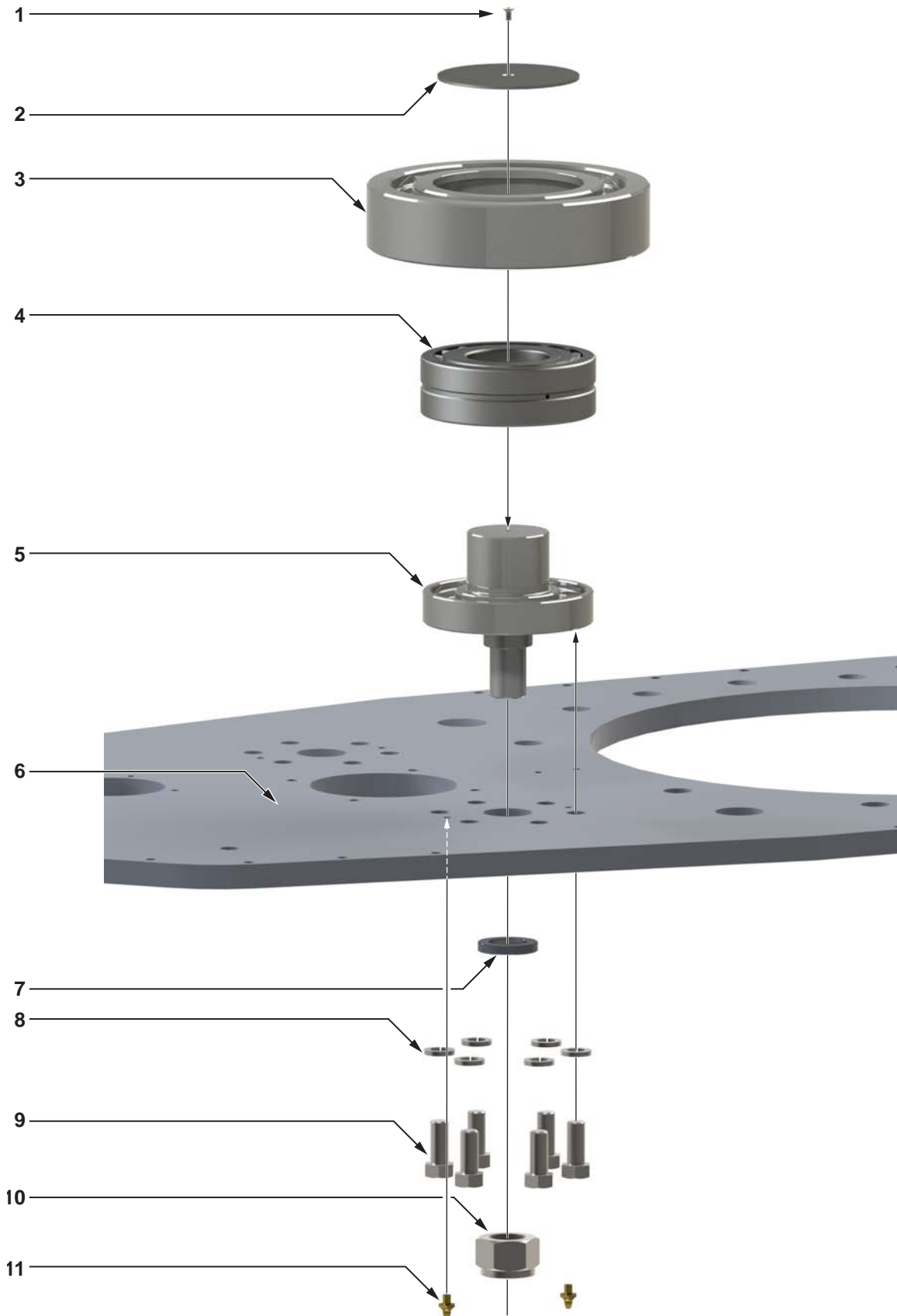
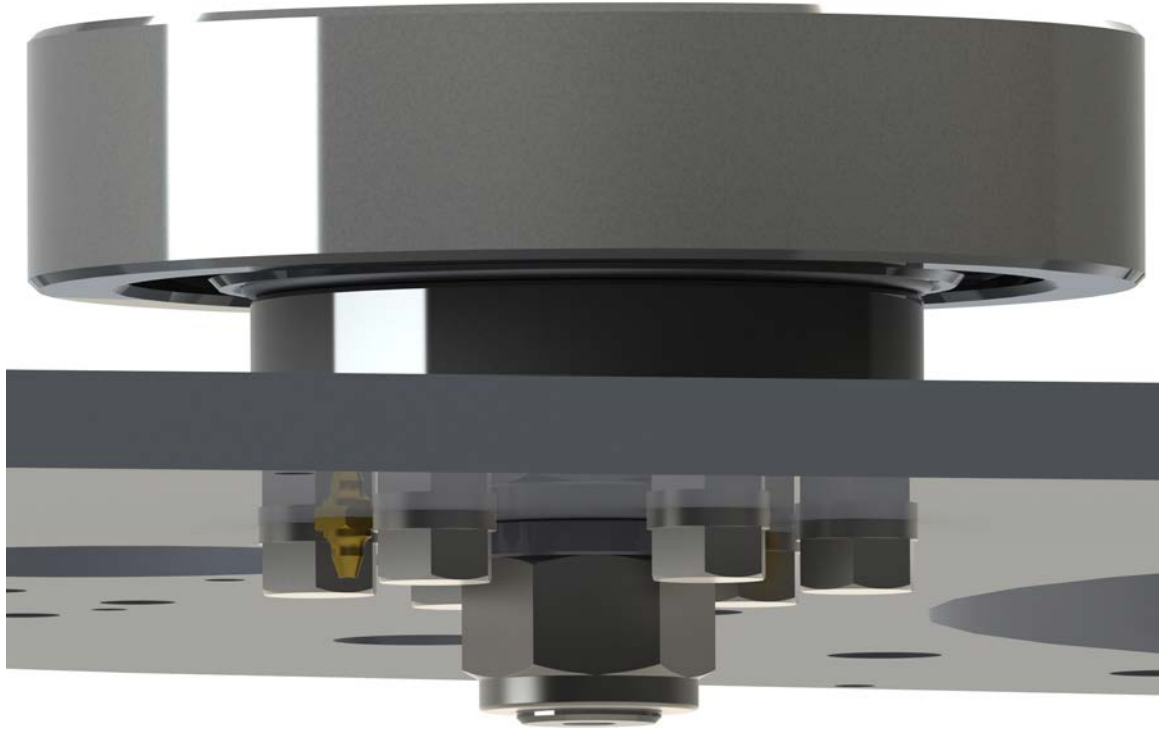
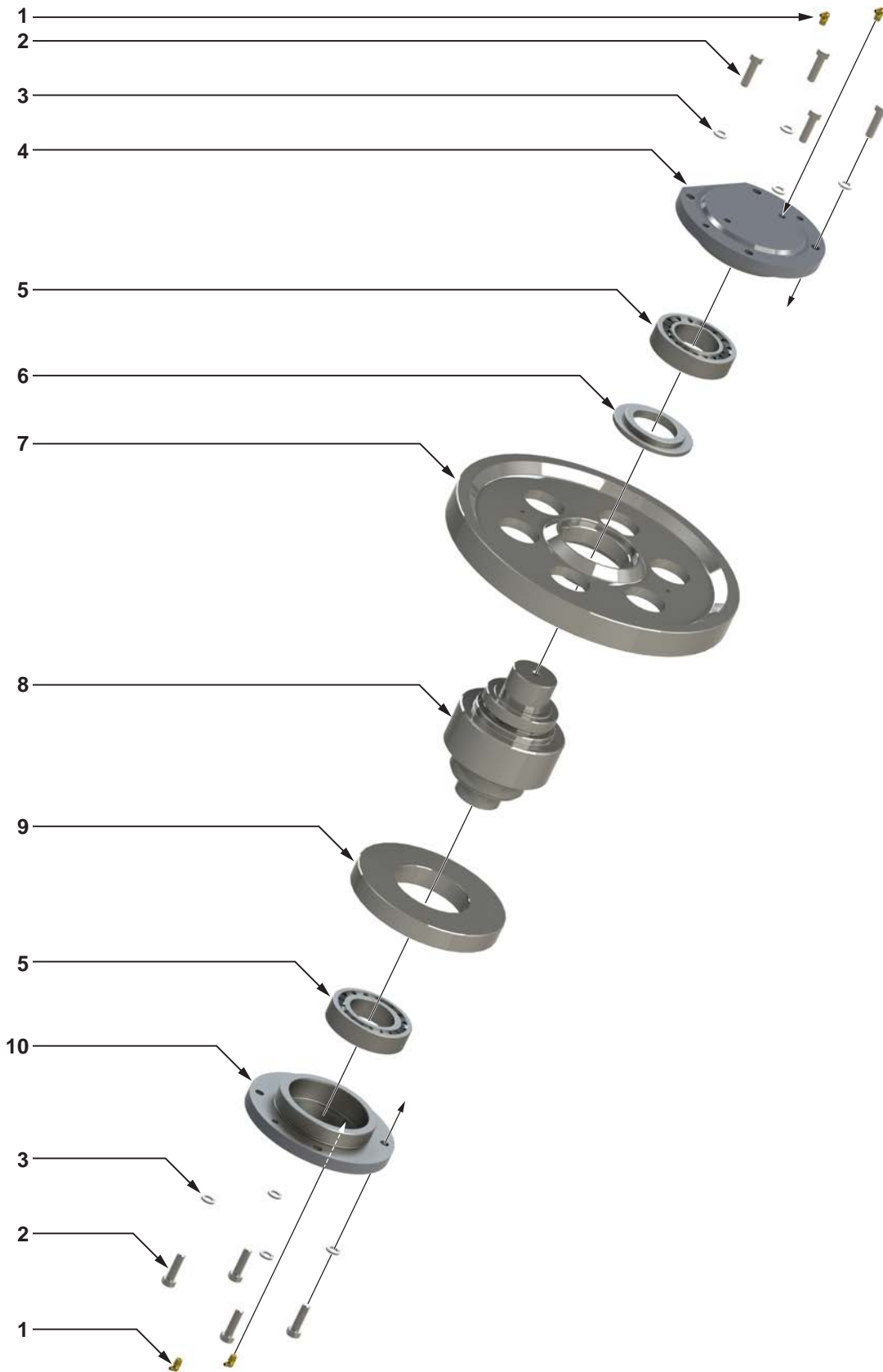


Illustration 5.7: Pinion Idler Exploded



**Illustration 5.8: Pinion Idler Gear Assembly**

Item	Type	Description	Qty	Part Number	Recommended Spares (Per Assembly)		
					Critical	One-Year	Overhaul
1	Part	¼" UNC x ½" hex socket flat head countersunk	1	09-4003			
2	Part	Retaining plate	1	101-5932			
3	Part	Idler gear	1	101-5930			
4	Part	Bearing	1	02-E0240			1
5	Part	Pinion idler half shaft	1	101-5931			
6	Part	Bottom plate (shown for illustration purposes)					
7	Part	Idler pad	1	101-6029			
8	Part	¾" Lock washers	6	09-5118			
9	Part	¾" UNC x 1-¾" hex bolt	6	09-1292			
10	Part	1-½" UNC nylock nut	1	09-5739			
11	Part	⅛" NPT grease fitting	2	02-0005			2



**Illustration 5.9: Pinion Gear Assembly Exploded**



**Illustration 5.10: Pinion Gear Assembly**

Item	Type	Description	Qty	Part Number	Recommended Spares (Per Assembly)		
					Critical	One-Year	Overhaul
1	Part	1/8" NPT 90° grease fitting	4	02-0093			4
2	Part	1/2" UNC x 1-1/2" hex bolt	8	09-1170			
3	Part	1/2" lock washer	8	09-5110			
4	Part	Top pinion bearing cap	1	1393-89			
5	Part	Pinion bearing	2	1393-93		2	2
6	Part	Pinion gear spacer	1	101-5929			1
7	Part	Low pinion gear	1	101-5927			
8	Part	Pinion gear	1	101-5926			
9	Part	High pinion gear	1	101-5928			1
10	Part	Lower pinion bearing cap	1	1393-89A			

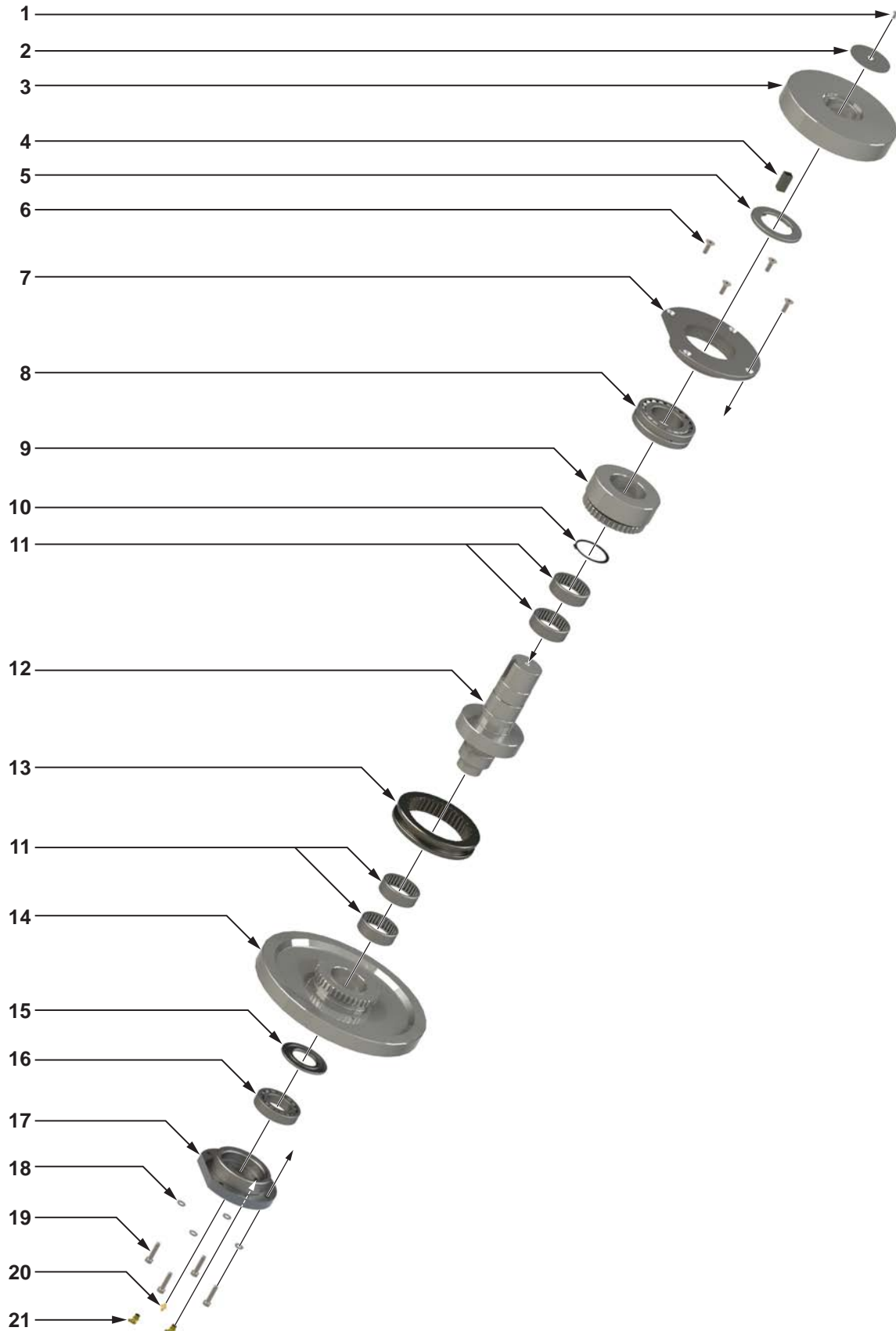


Illustration 5.11: Clutch Gear Assembly Exploded



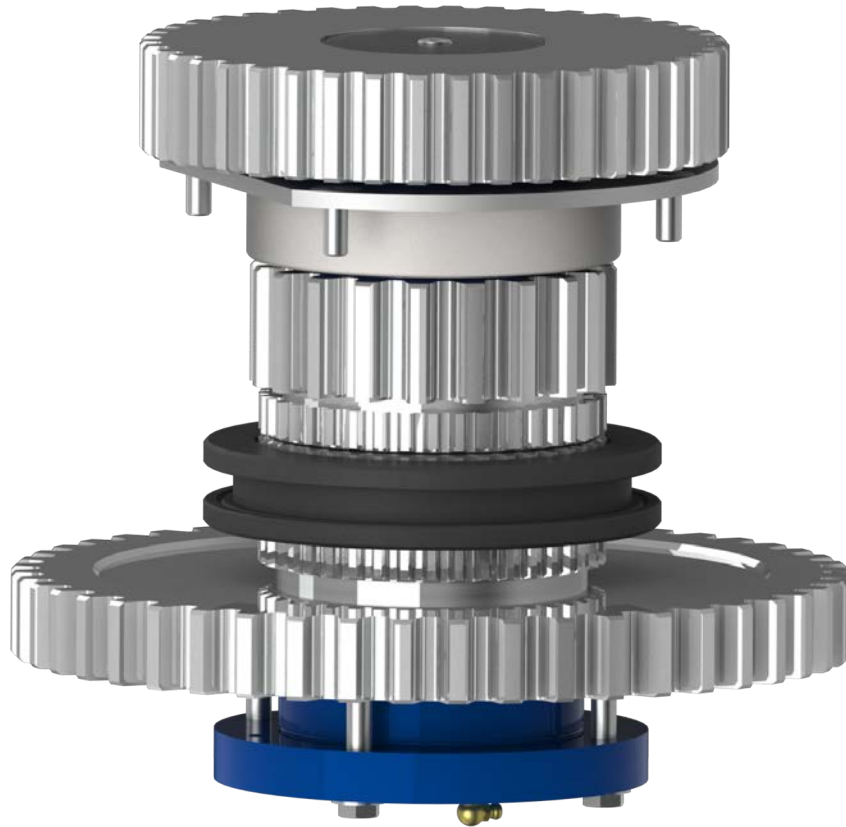
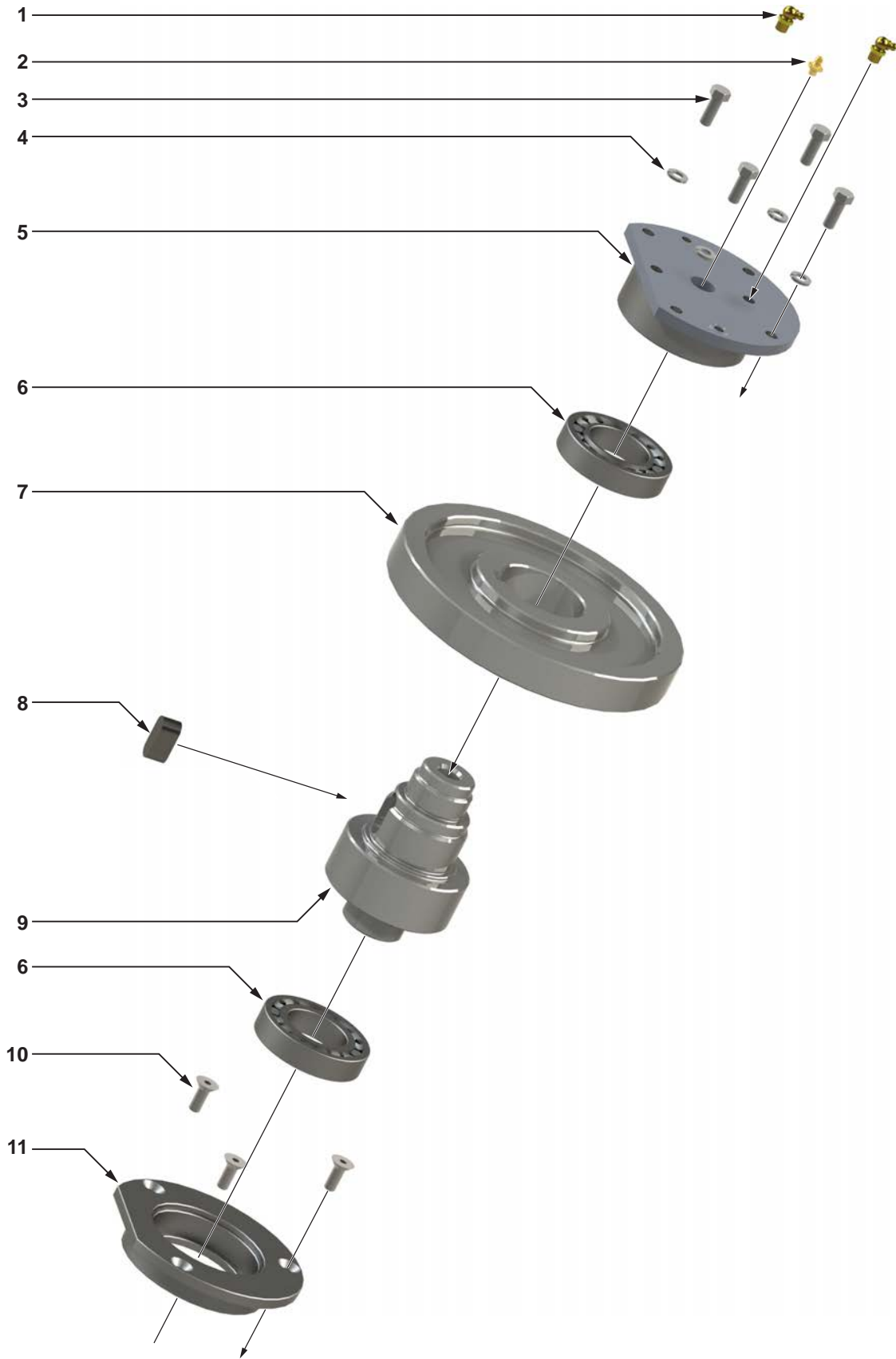


Illustration 5.12: Clutch Gear Assembly

Item	Type	Description	Qty	Part Number	Recommended Spares (Per Assembly)		
					Critical	One-Year	Overhaul
1	Part	¼" UNC x 1" hex socket flat head machine screws	1	09-4007			
2	Part	Clutch shaft retainer plate	1	1393-50-04			
3	Part	Clutch drive gear	1	101-5950	1		1
4	Part	Gear key	1	101-5924	1		1
5	Part	Clutch gear spacer	1	101-5949			1
6	Part	⅜" UNC x 1" hex socket flat head machine screws	4	09-4046			
7	Part	Clutch bearing plate	1	101-5925			
8	Part	Top clutch shaft bearing	1	02-E0236		1	1
9	Part	Low clutch gear	1	101-5921			1
10	Part	Retaining ring	1	02-E0237			1
11	Part	Clutch gear needle bearing	4	1393-53			4
12	Part	Clutch shaft	1	101-5920			1
13	Part	Shifting collar	1	1393-62			1
14	Part	High clutch gear	1	101-5922			1
15	Part	Lower clutch shaft spacer	1	101-5923			1
16	Part	Lower clutch bearing	1	1393-55		1	1
17	Part	Clutch bearing cap	1	1393-54			
18	Part	⅜" lock washers	4	09-5106			
19	Part	⅜" UNC x 1-¾" hex bolt	4	09-1557			
20	Part	⅜" NPT grease fitting	1	02-0005			1
21	Part	⅜" NPT 90° grease fitting	2	02-0093			2



**Illustration 5.13: Lay Gear Assembly Exploded**



**Illustration 5.14: Lay Gear Assembly**

Item	Type	Description	Qty	Part Number	Recommended Spares (Per Assembly)		
					Critical	One-Year	Overhaul
1	Part	1/8" NPT 90° grease fitting	2	02-0093			2
2	Part	1/8" NPT grease fitting	1	02-0005			1
3	Part	3/8" UNC x 1" hex bolt	4	09-1170			
4	Part	3/8" lock washer	4	09-5106			
5	Part	Lay gear bearing cap	1	1393-151			
6	Part	Bearing	2	1393-55		2	2
7	Part	Lay gear	1	101-5917			1
8	Part	Gear key	1	101-5918			1
9	Part	Lay gear shaft	1	101-5916			
10	Part	3/8" UNC X 1" hex socket head countersunk	3	09-4046			
11	Part	Bottom lay gear bearing holder	1	101-5919			

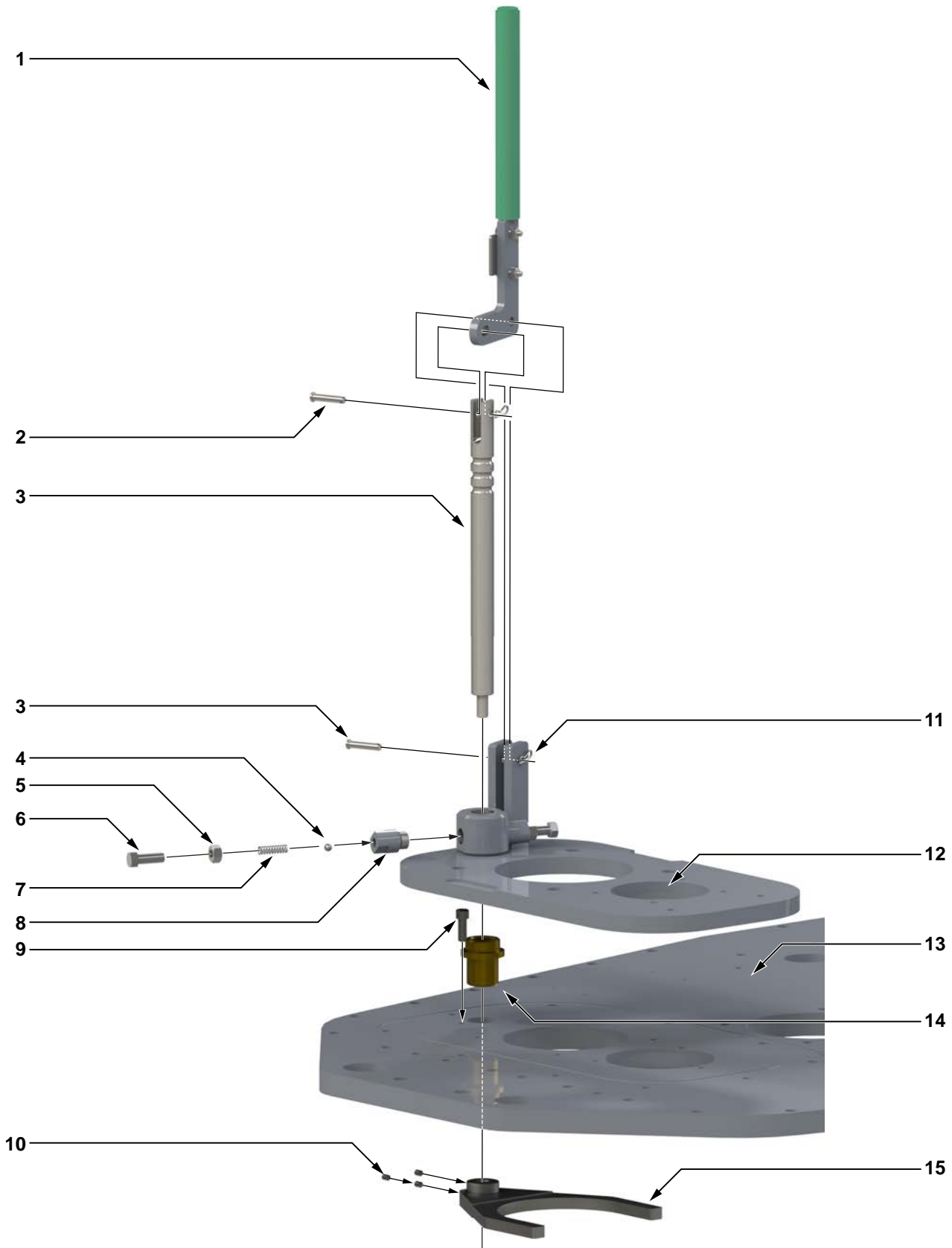


Illustration 5.15: Shifter Assembly Exploded



**Illustration 5.16: Shifter Assembly**

Item	Type	Description	Qty	Part Number	Recommended Spares (Per Assembly)		
					Critical	One-Year	Overhaul
1	Weldment	Shifter handle	1	101-1749			
2	Part	$\frac{3}{8}$ " x 1- $\frac{1}{2}$ " clevis pin	2	09-7116		2	2
3	Part	Shifting shaft	1	101-6009	1		1
4	Part	Shifter detent ball	2	02-0018		2	2
5	Part	$\frac{7}{16}$ " UNF hex nut	2	09-5908			
6	Part	$\frac{7}{16}$ " UNF x 1- $\frac{1}{4}$ " hex bolt	2	09-1608			
7	Part	Shifter detent spring	2	997-0-64		2	2
8	Part	Threaded shifter detent tube	2	101-1497			
9	Part	$\frac{3}{8}$ " x 1" thin head hex SHCS	1				
10	Part	$\frac{1}{4}$ " UNC x $\frac{3}{8}$ " hex socket head set screw	3	09-0107			
11	Part	0.093" x 1- $\frac{1}{8}$ " hitch pin	2	02-0274		2	2
12	Part	Top motor mount plate - shown for illustration purposes only					
13	Part	Top tong plate - shown for illustration purposes only					
14	Part	Lower shifter bushing	1	1393-78			1
15	Part	Shifting fork	1	101-6106	1		1

**ASSEMBLY NOTE:** The top shifter bushing, PN 101-1496, and the pivot arms, PN 1393-76, are typically welded to the motor mount housing weldment, PN 101-1808.

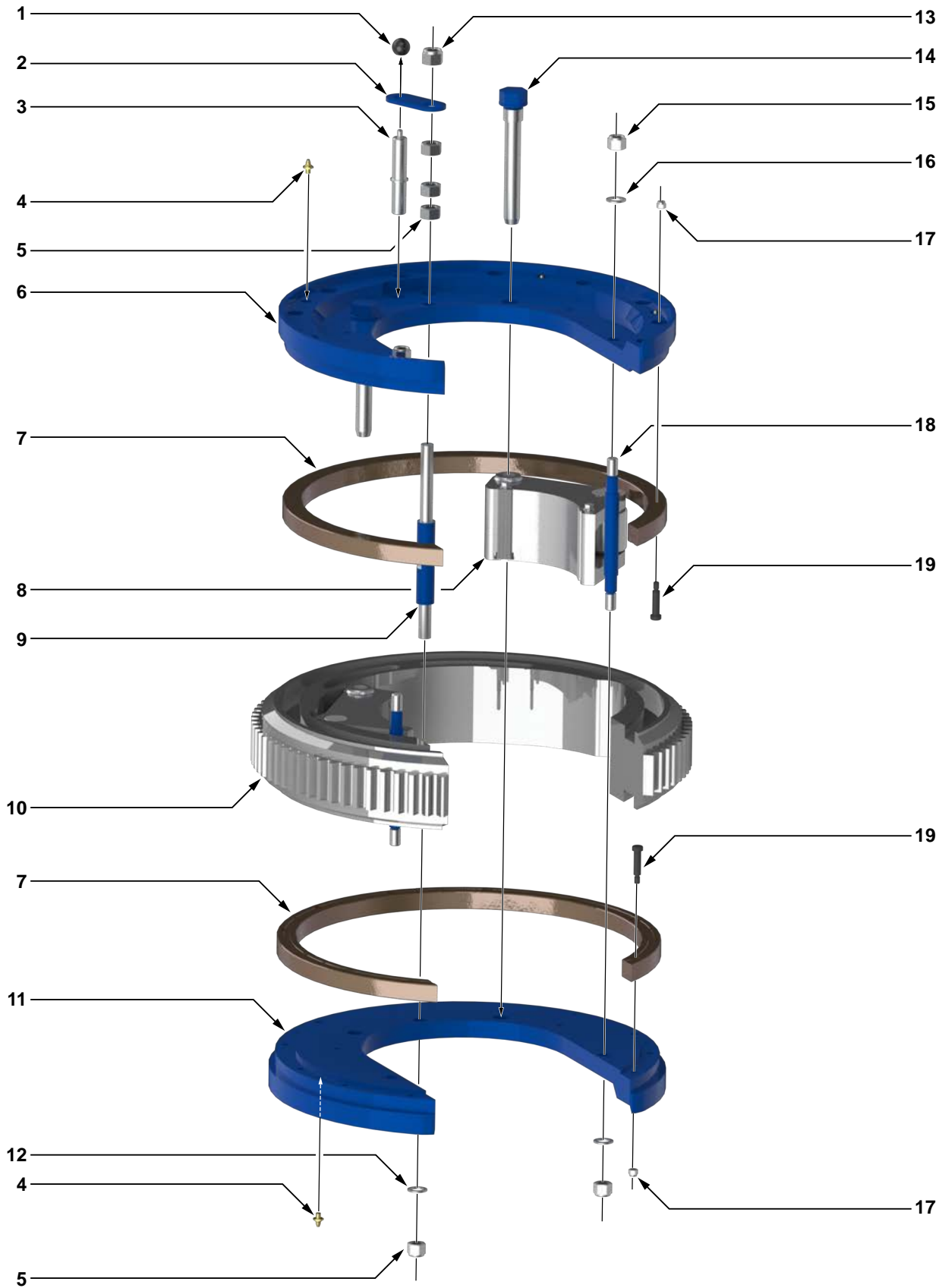
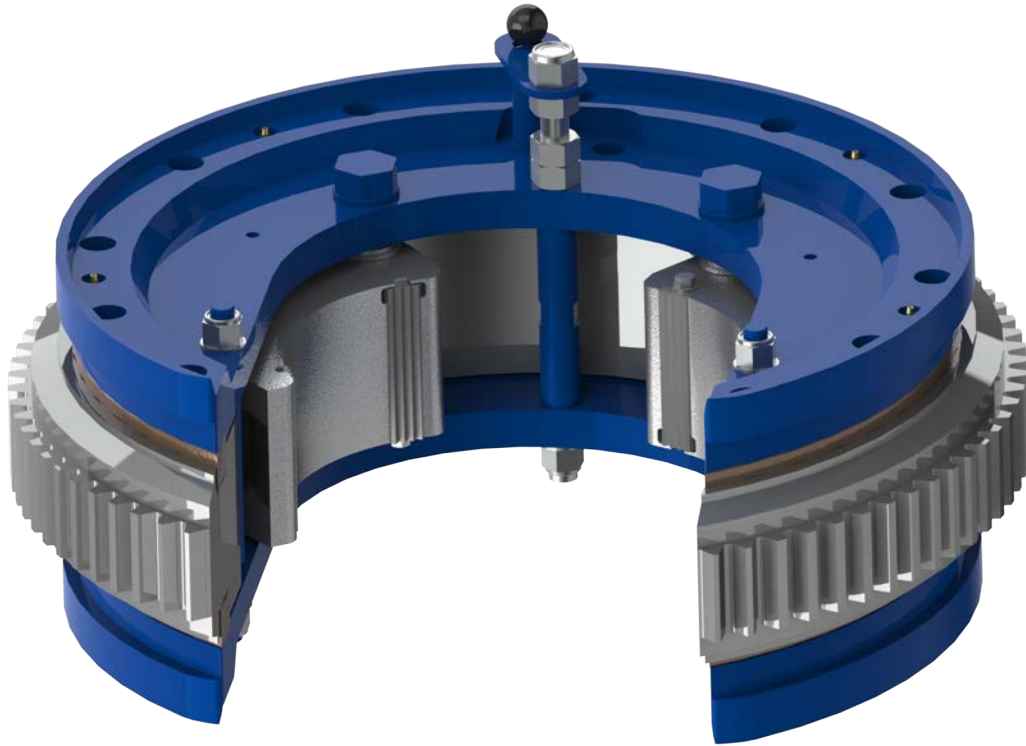


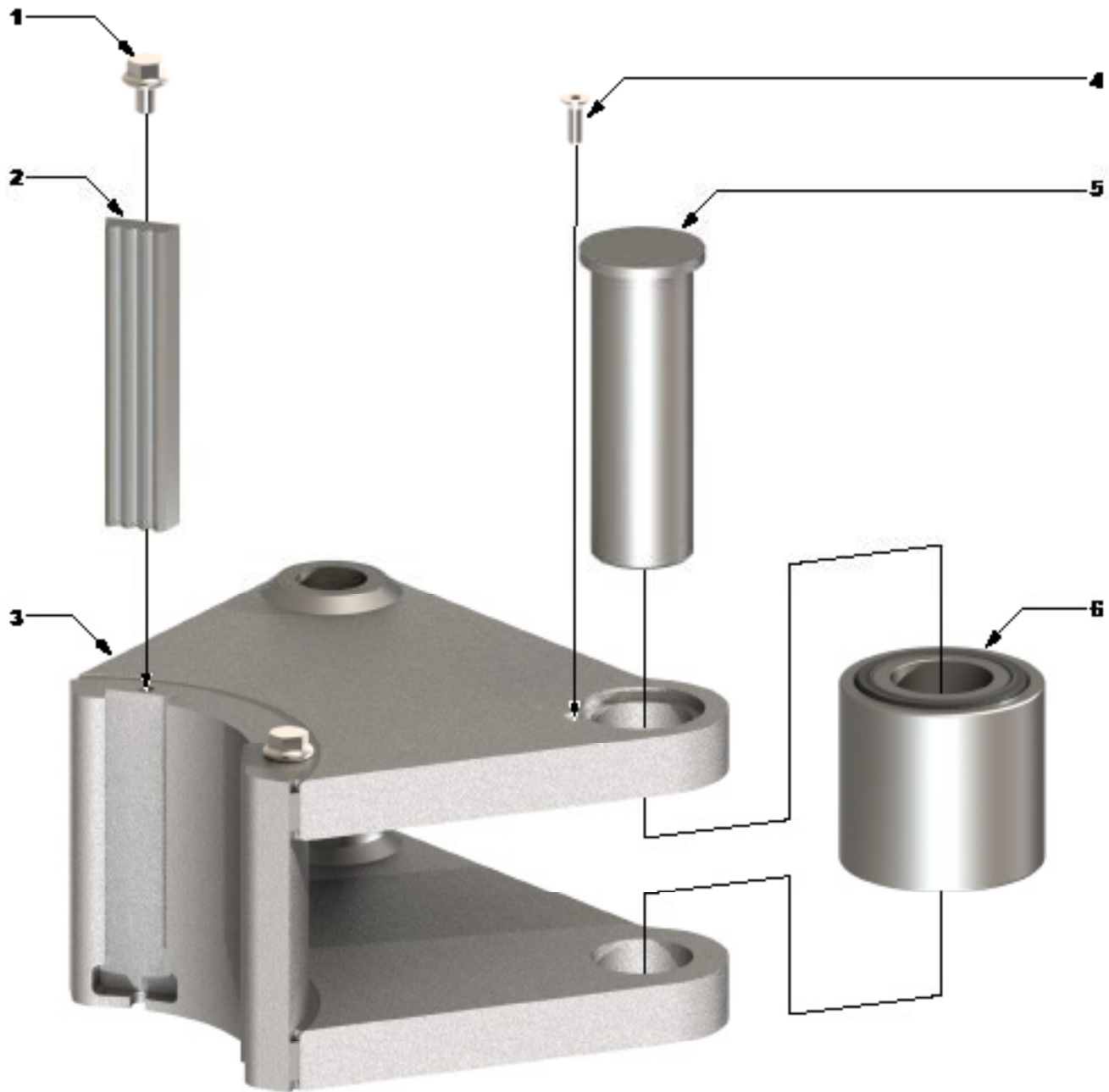
Illustration 5.17: Cage Plate Assembly Exploded



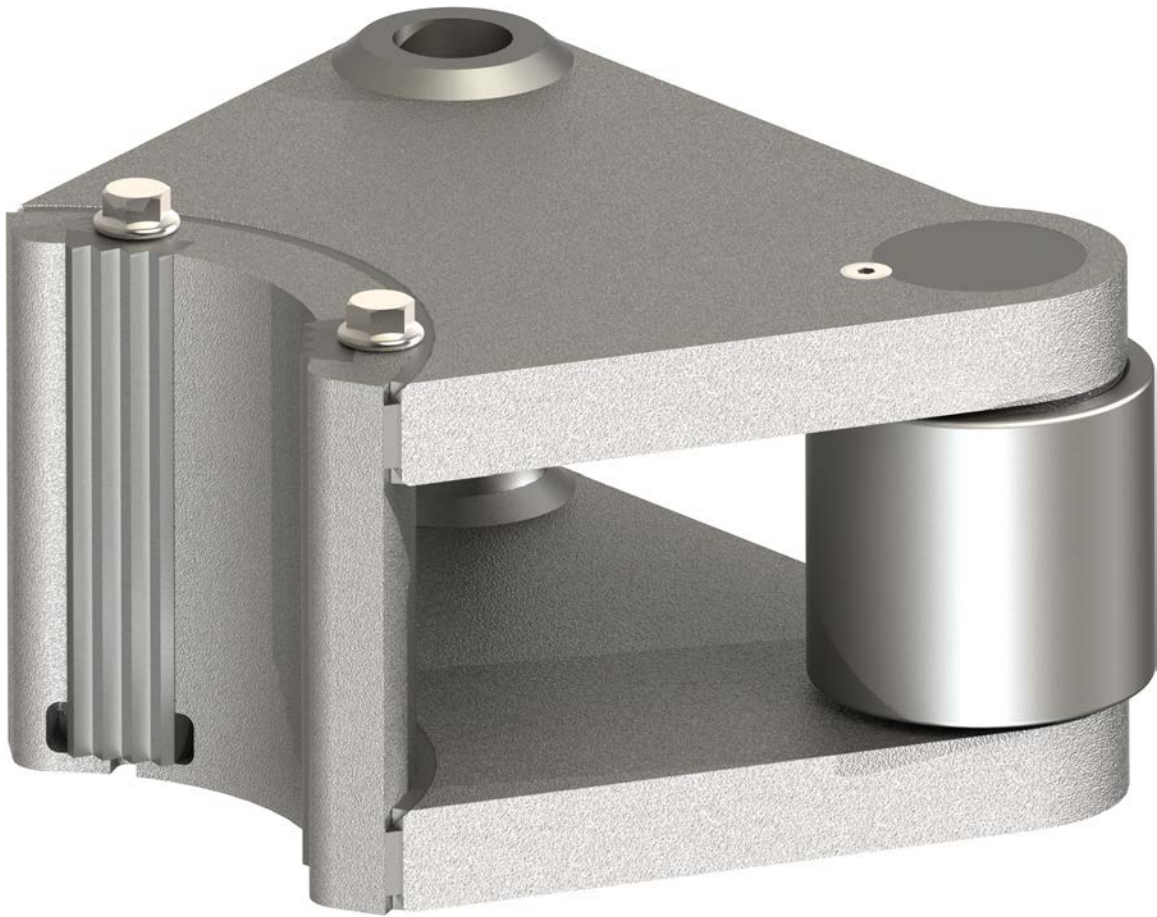
**Illustration 5.18: Cage Plate Assembly**

Item	Type	Description	Qty	Part Number	Recommended Spares (Per Assembly)		
					Critical	One-Year	Overhaul
1	Part	Backing pin knob	1	02-0017		1	1
2	Part	Backing pin retainer	1	1393-40		1	1
3	Part	Backing pin	1	1393-39	1		1
4	Part	1/8" NPT grease fitting	8	02-0005			8
5	Part	7/8" UNC hex nut	4	09-5822			
6	Part	Top cage plate	1	1393-21			
7	Part	Guide ring	2	1393-23	1		2
8	Assembly	Jaw assembly (11" shown - see Pp. 5.24 - 5.29)	2	See Pp. 2.17			
9	Part	Rear cage plate bolt/spacer	1	1393-36	1		1
10	Part	Rotary gear	1	101-6204			
11	Part	Bottom cage plate	1	1393-22			
12	Part	7/8" lock washer	1	09-5122			
13	Part	7/8" UNC nylock nut	1	09-5721			
14	Part	Jaw pivot bolt	2	1393-28	2		2
15	Part	3/4" UNC Hex nut	4	09-5818			
16	Part	3/4" lock washer	4	09-5118			
17	Part	3/8" UNC nylock nut	22	09-5607			
18	Part	Front cage plate spacer	2	101-3630		2	2
19	Part	1/2" x 1-3/4" UNC shoulder bolt	22	09-0103			





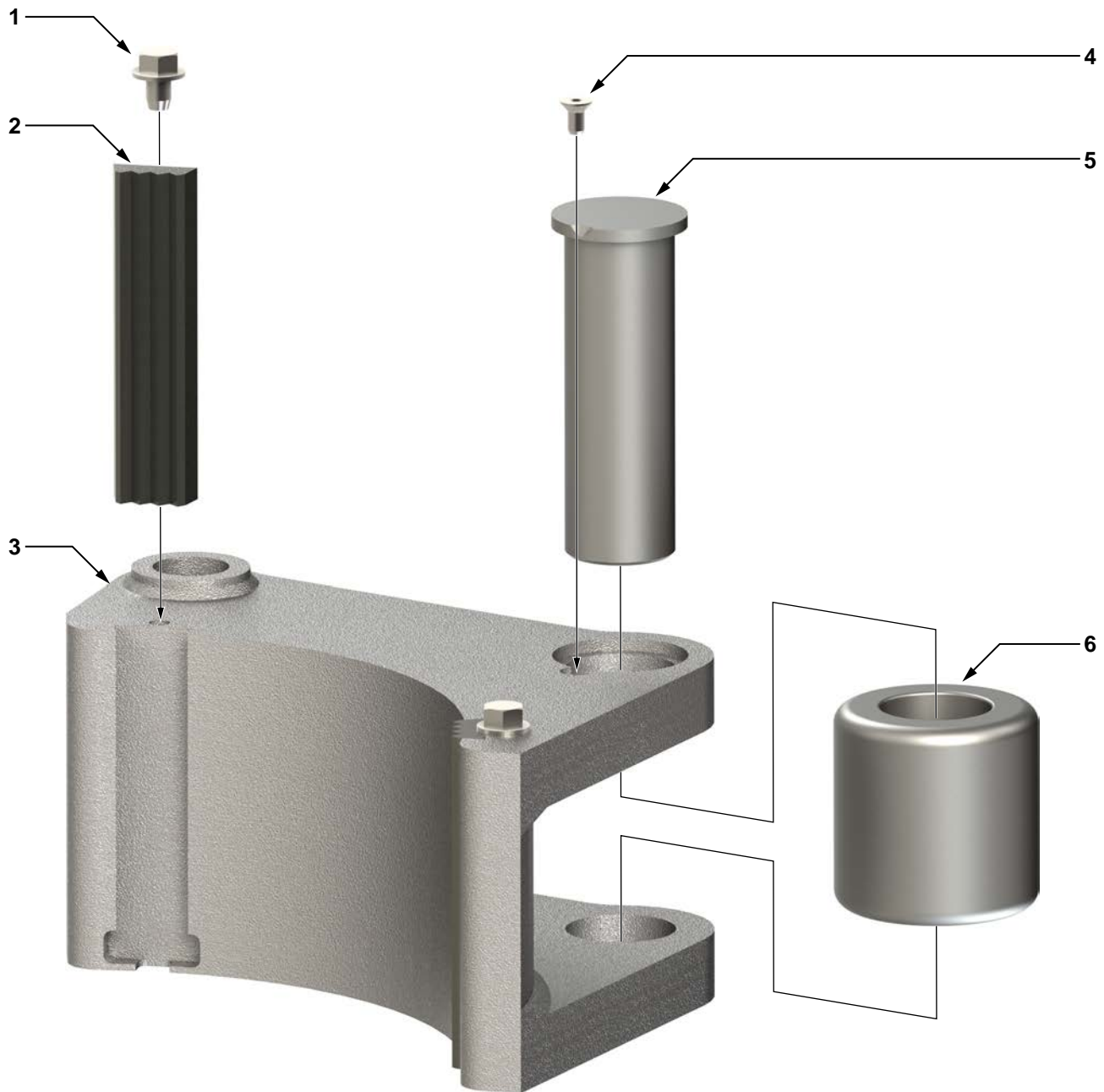
**Illustration 5.19: 3-1/2" to 5-1/2" Jaw Assembly Exploded**



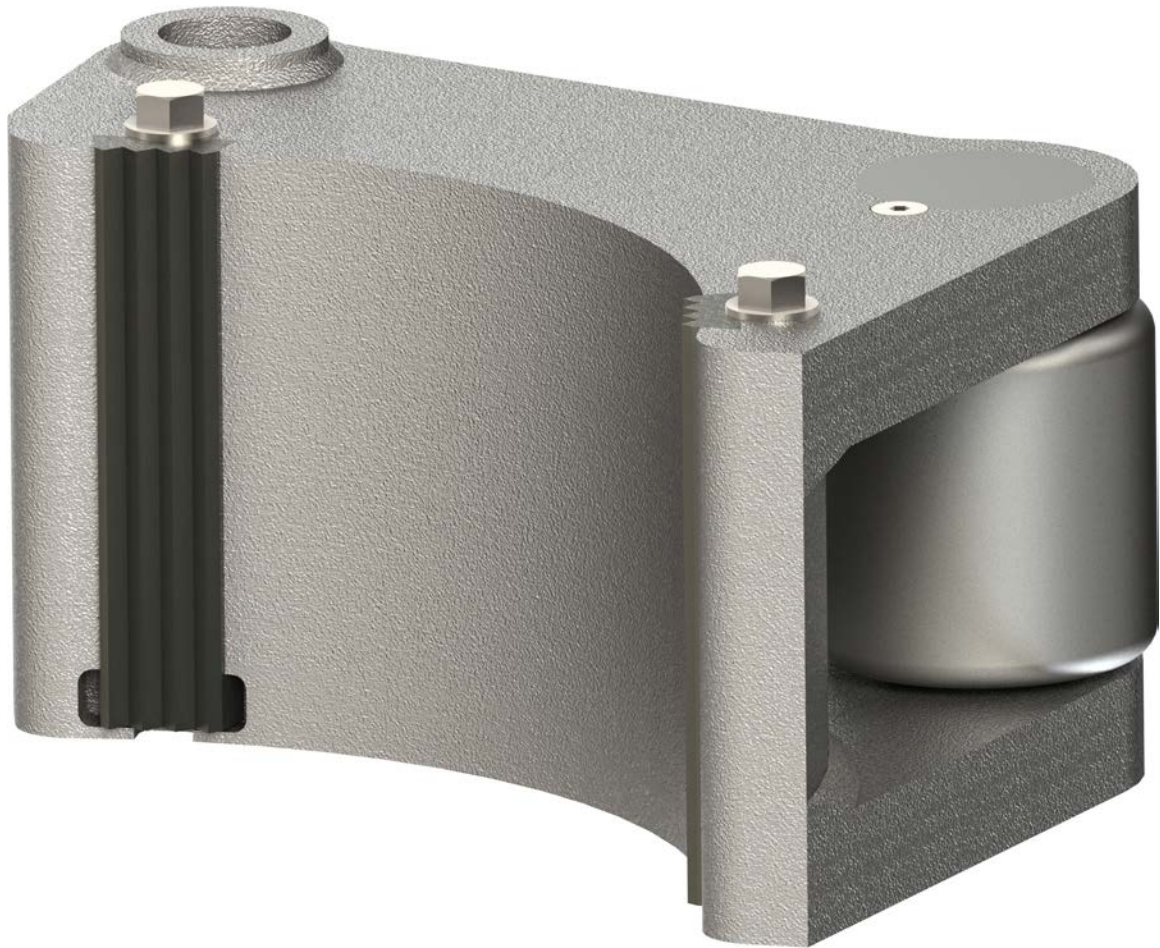
**Illustration 5.20: 3-½" to 5-½" Jaw Assembly**

Item	Type	Description	Qty	Part Number	Recommended Spares (Per Assembly)		
					Critical	One-Year	Overhaul
1	Part	⅜" UNC x ½" flange head machine screw	2	02-9292	2		
2	Part	Standard 5" die insert	2	13-0008-500-0	8		
3	Part	Jaw Weldment	1	1393-J-XXXX <sup>(1)</sup>			
4	Part	¼" UNC x ½" Hex Flat Countersunk Cap Screw	1	09-4003			
5	Part	Jaw Pin	1	1393-JP	1		
6	Assembly	Jaw Roller/Bearing Assembly	1	1393-J-550-A	1		

1 XXXX = size. Example: 1393-J-0500 = 5-½" jaw weldment



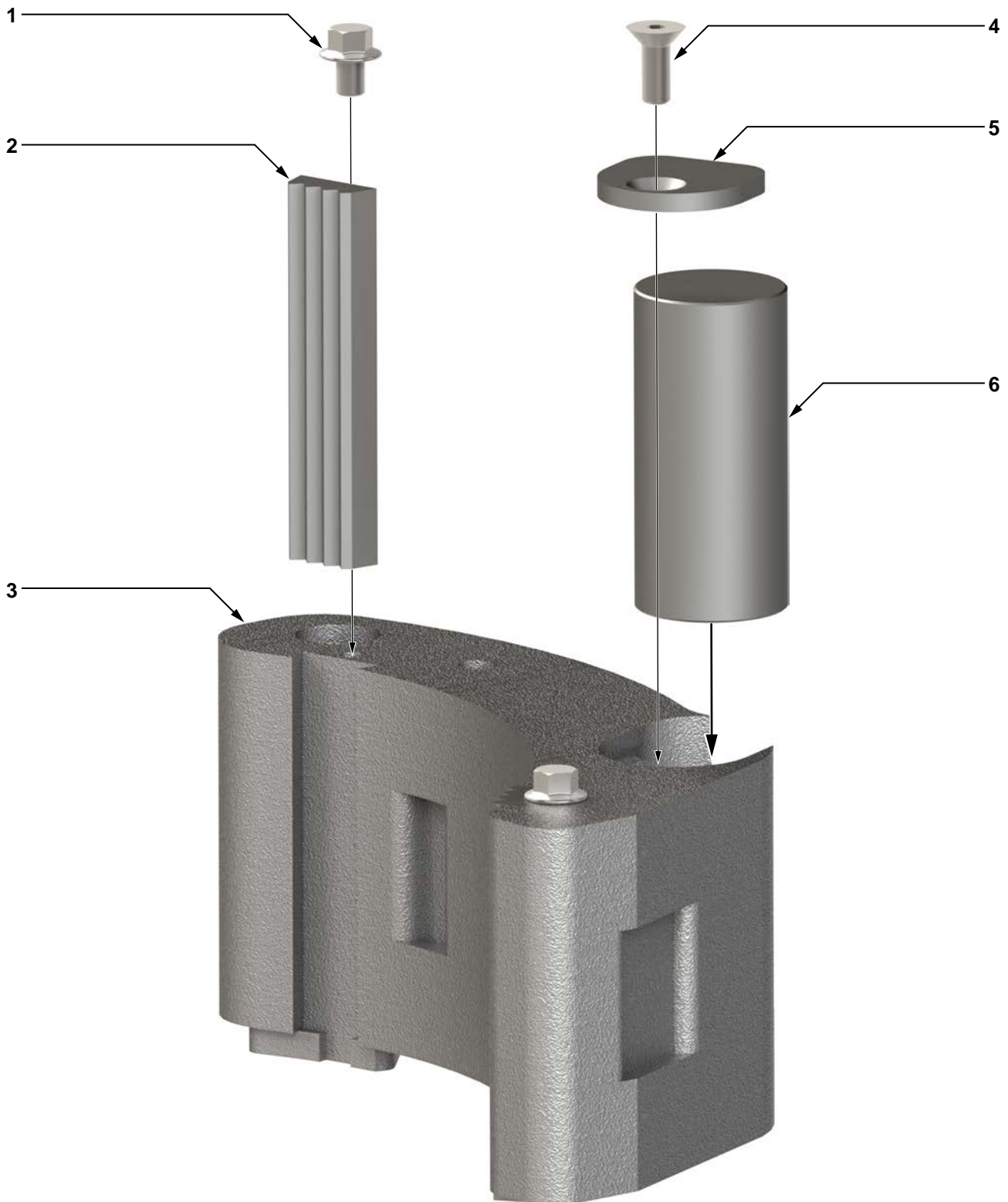
**Illustration 5.21: 6-<sup>5</sup>/<sub>8</sub> through 13-<sup>5</sup>/<sub>8</sub>, 14-<sup>3</sup>/<sub>8</sub> Jaw Assembly Exploded**



**Illustration 5.22: 6-5/8 through 13-5/8, 14-3/8 Jaw Assembly**

Item	Type	Description	Qty	Part Number	Recommended Spares (Per Assembly)		
					Critical	One-Year	Overhaul
1	Part	3/8" UNC x 1/2" flange head machine screw	2	02-9292	2		
2	Part	Standard 5" die insert	2	13-0008-500-0	8		
3	Part	Jaw Weldment	1	1393-J-XXXXX <sup>(1)</sup>			
4	Part	1/4" UNC x 1/2" Hex Flat Countersunk Cap Screw	1	09-4003			
5	Part	Jaw Pin	1	1393-JP	1		
6	Part	Jaw Roller	1	1393-JR-300	1		

1 XXXXX = size. Example: 1393-J-11000 = 11" jaw weldment



**Illustration 5.23: 14" Jaw Assembly Exploded**





**Illustration 5.24: 14" Jaw Assembly**

Item	Type	Description	Qty	Part Number	Recommended Spares (Per Assembly)		
					Critical	One-Year	Overhaul
1	Part	3/8" UNC x 1/2" flange head machine screw	2	02-9292	2		
2	Part	Standard 5" die insert	2	13-0008-500-0	8		
3	Part	Jaw Weldment	1	1393-J-14000			
4	Part	3/8" UNC x 1" Hex Flat Countersunk Cap Screw	1	09-4046			
5	Part	Jaw roller retainer	1	101-6042	1		
6	Part	Jaw Roller	1	1393-JR-2000	1		

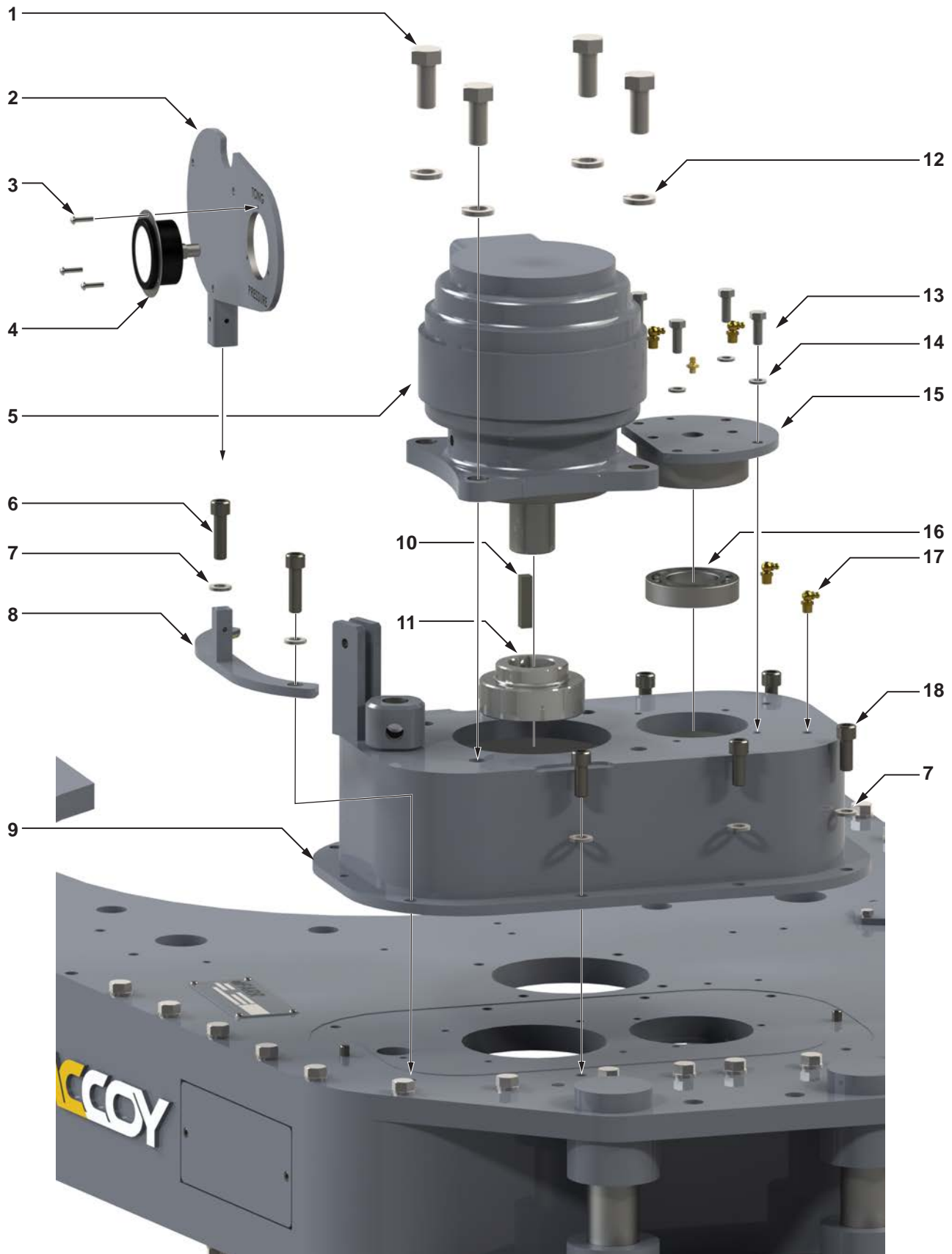
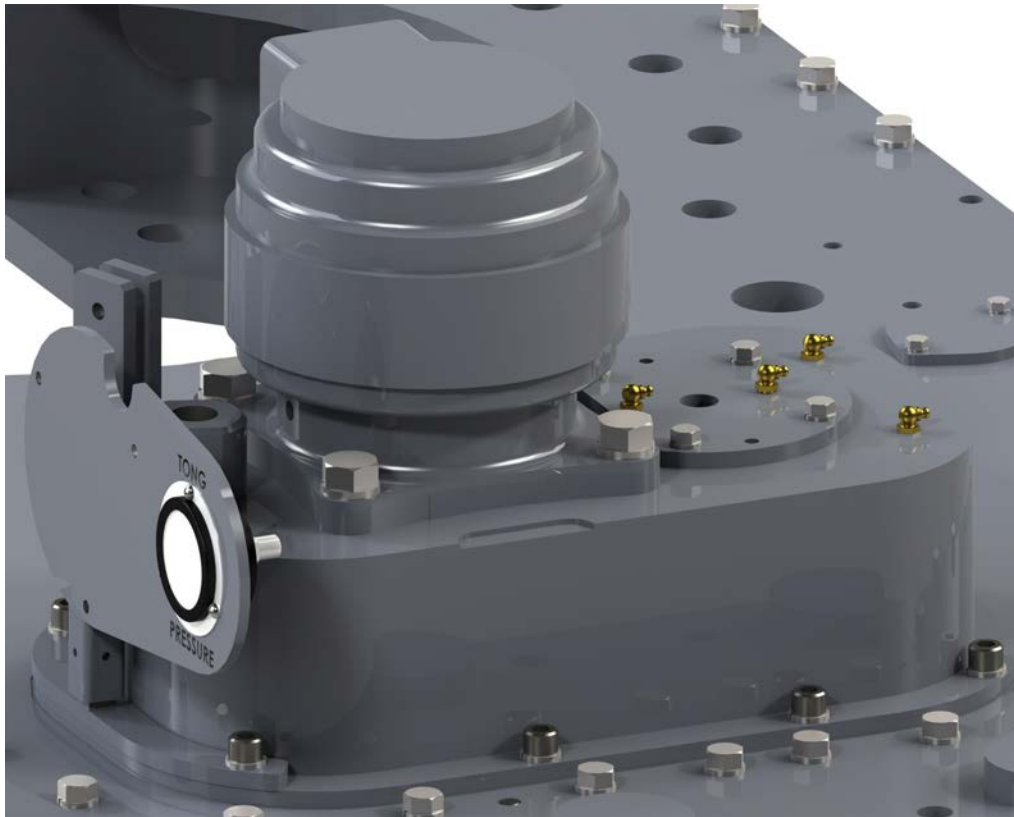


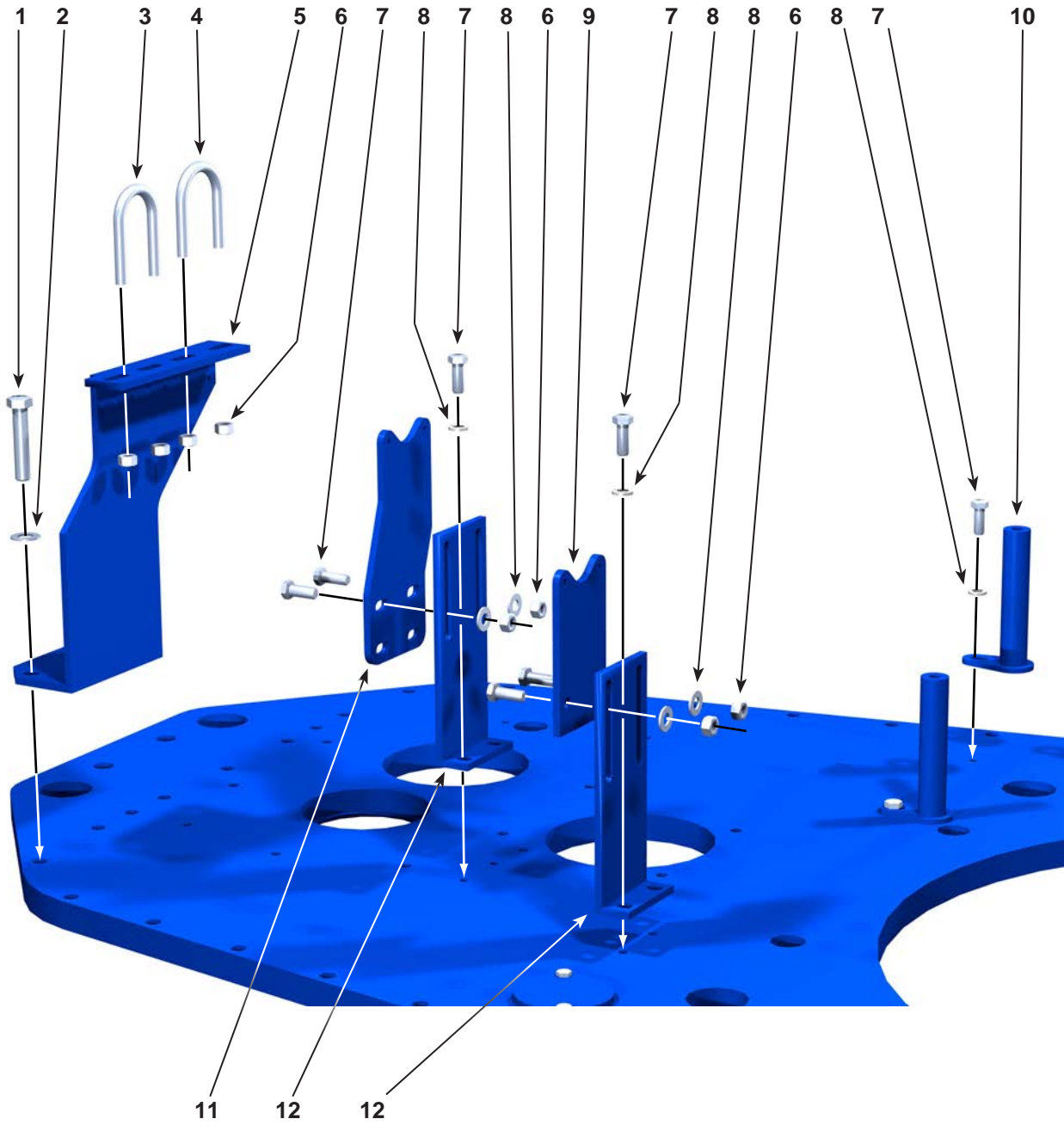
Illustration 5.25: Motor & Mount Exploded



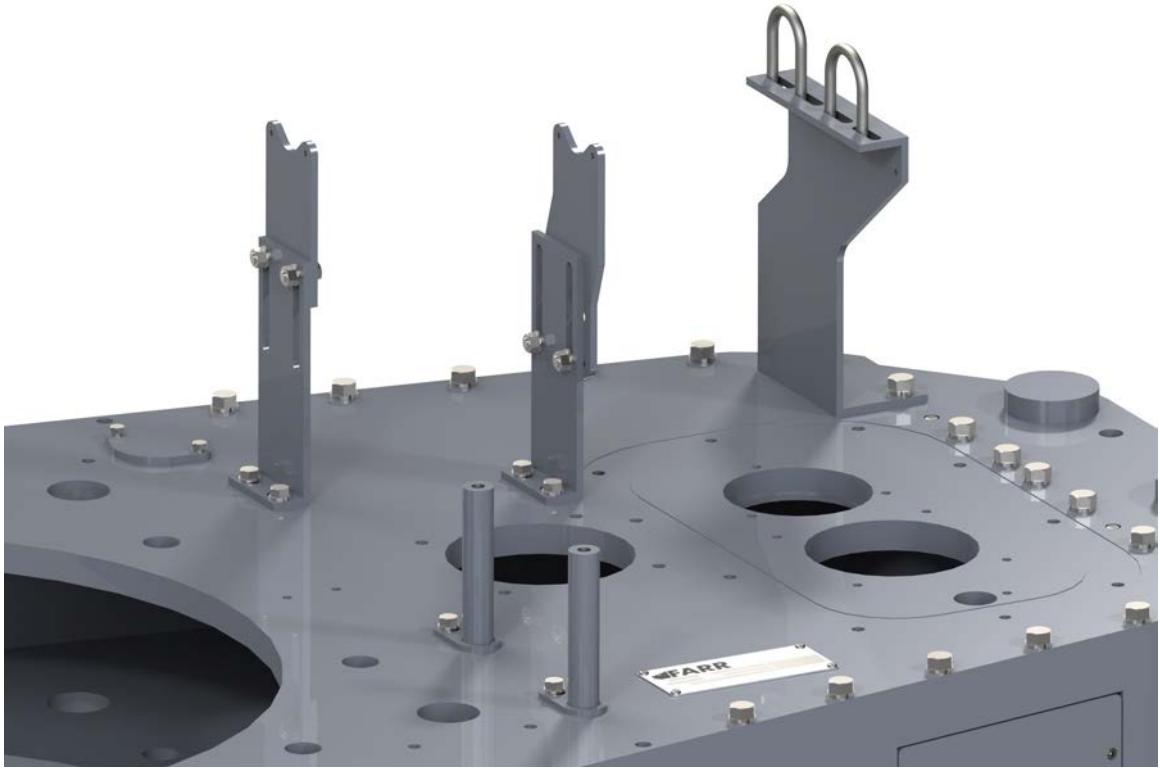


**Illustration 5.26: Motor & Mount**

Item	Type	Description	Qty	Part Number	Recommended Spares (Per Assembly)		
					Critical	One-Year	Overhaul
1	Part	3/4" UNC x 1-3/4" Hex Bolt	4	09-1292			
2	Weldment	Torque/Pressure Gauge Mount Weldment	1	101-6075			
3	Part	10-24 x 3/4" Round Head Machine Screw	3				
4	Part	0 - 3000 PSI Pressure Gauge	1	02-0245		1	
5	Part	Rineer Hydraulic Motor	1	87-0130			
6	Part	1/2" UNC x 1-3/4" Hex Socket Head Cap Screw	2	09-2172			
7	Part	1/2" Lock Washer	8	09-5110			
8	Weldment	Torque/Pressure Gauge Holder Weldment	1	101-1621			
9	Weldment	Motor Mount Weldment	1	101-1808			
10	Part	Square 1/2" x 1/2" x 2 Motor Gear Key	1	101-3596			1
11	Part	Motor Gear	1	101-5951		1	1
12	Part	3/4" Lock Washer	4	09-5118			
13	Part	3/8" UNC x 1" Hex Bolt	4	09-1170			
14	Part	3/8" Lock Washer	4	09-5006			
15	Part	Lay Gear Bearing Cap	1	1393-151			
16	Part	Top Lay Gear Bearing	1	1393-55	See Pp 5.18 - 5.19		
17	Part	1/8" NPT x 90° Grease Fitting	2	02-0093			
18	Part	1/2" UNC x 1-1/4" Hex Socket Head Cap Screw	6	09-2170			
19	Part	1/4" UNC x 3/8" Set Screw (Motor Gear - Not Shown)	3	09-0107			3
20	Kit	Motor Seal Kit	87-7130			1	1

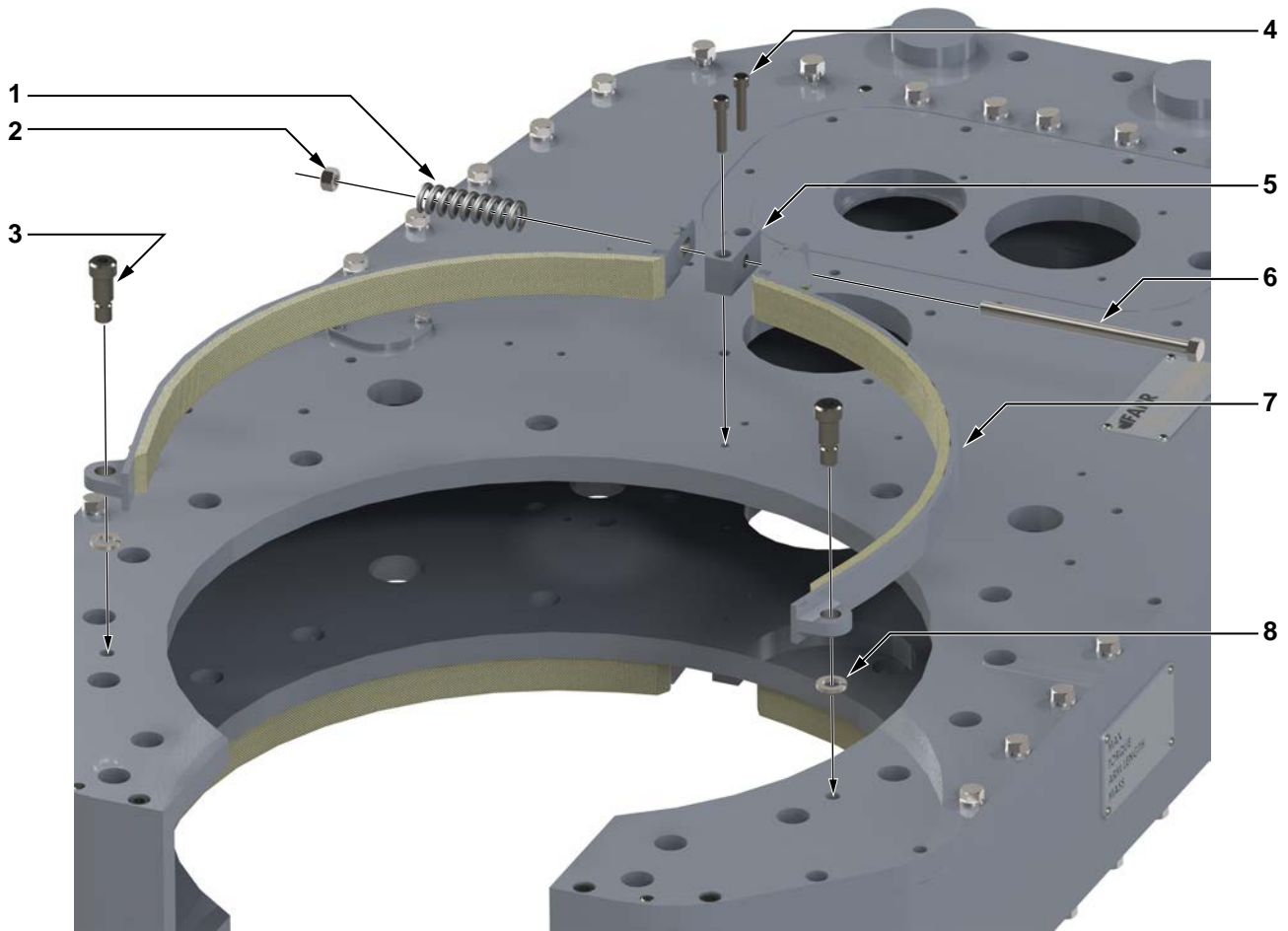


**Illustration 5.27: Hydraulic Supports Exploded**



**Illustration 5.28: Hydraulic Supports**

Item	Type	Description	Qty	Part Number	Recommended Spares (Per Assembly)		
					Critical	One-Year	Overhaul
1	Part	½" UNC x 2-½" Hex Bolt	2	09-1176			
2	Part	½" Lock Washer	12	09-5119			
3	Part	¾" UNC U-Bolt 1-½" I.D.	1	101-2075			
4	Part	¾" UNC U-Bolt 1-¾" I.D.	1	101-2076			
5	Weldment	Hydraulic Pipe Mount Weldment	1	101-1806			
6	Part	¾" UNC Hex Nut	8	09-5806			
7	Part	¾" UNC x 1" Hex Bolt	10	09-1170			
8	Part	¾" Lock washer	10	09-5106			
9	Part	Coupling Support Mount Plate	1	101-0022			
10	Weldment	Valve Mount Weldment	2	101-1442			
11	Part	Coupling Support Mount Plate	1	101-1583			
12	Weldment	Hydraulic Coupling Support Weldment	2	101-1138			



**Illustration 5.29: Brake Bands Exploded**



Illustration 5.30: Brake Bands

Item	Type	Description	Qty	Part Number	Recommended Spares (Per Assembly)		
					Critical	One-Year	Overhaul
1	Part	Brake Band Spring	1	1404-29-04		1	1
2	Part	½" UNC Hex Nut	1	09-9124			
3	Part	¾" x 1" Hex Socket UNC Shoulder Bolt	2	09-0190		2	2
4	Part	⅜" UNC x 1-¾" Hex Socket Head Cap Screw	2	09-2052			
5	Part	Brake Band Retainer Lug	1	101-5965			
6	Part	½" UNC x 8-½" Adjustment Bolt	1	09-1200		1	
7	Part	Lined Brake Band Weldment	1	101-5966	2		2
8	Part	⅝" Lock Washer	2	09-5114			

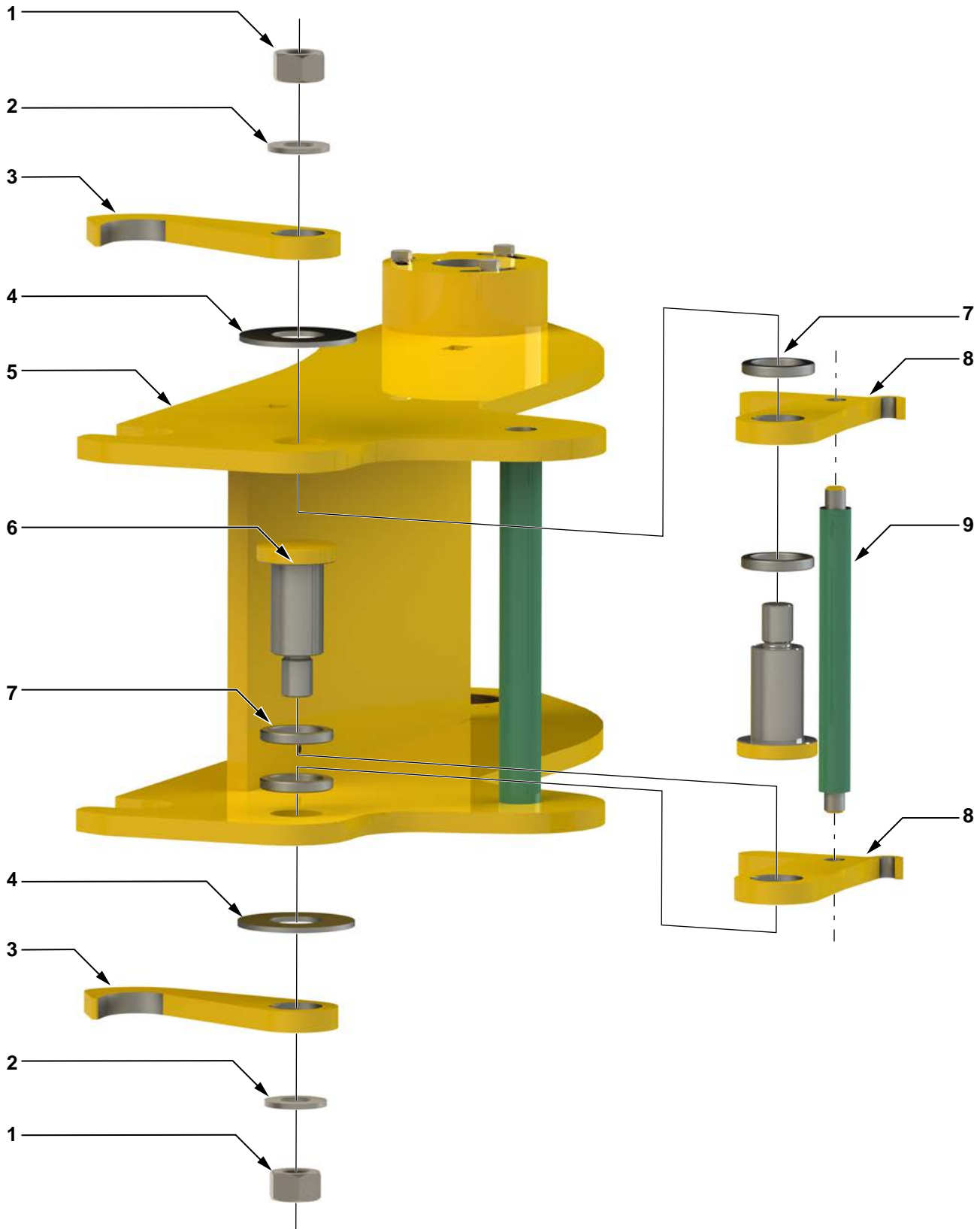


Illustration 5.31: Door Latch Assembly Exploded

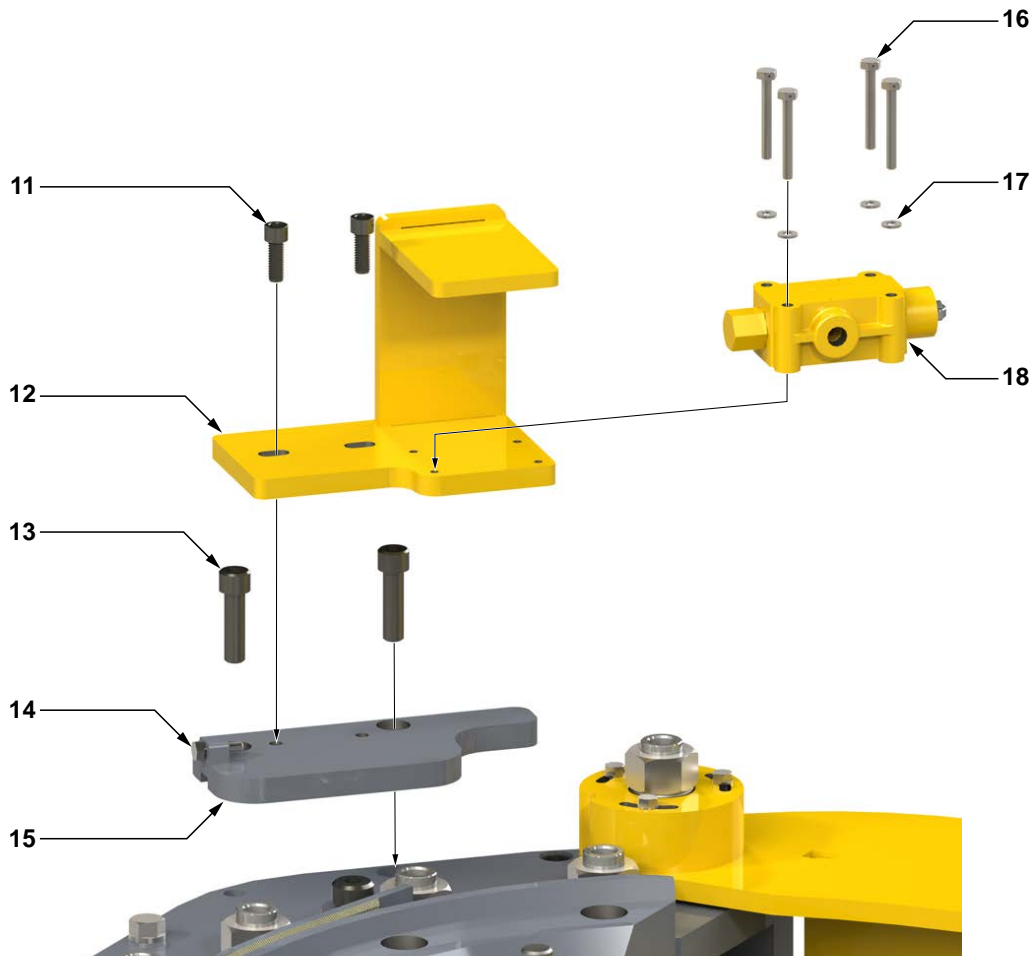


Illustration 5.32: Safety Door Components Exploded

Item	Type	Description	Qty	Part Number	Recommended Spares (Per Assembly)		
					Critical	One-Year	Overhaul
1	Part	3/4" UNC Nylock Nut	2	1429-39-02		2	2
2	Part	3/4" Narrow Flat Washer	2	09-5013		2	2
3	Part	Latch Claw	2	101-5982	2		2
4	Part	Door Latch Bushing	2	101-4885		2	2
5	Weldment	Door Weldment	1	101-5978			
6	Part	Latch Pin	2	101-5986		2	2
7	Part	Door Latch Spacer	4	101-5997	4		4
8	Part	Latch Lever	2	101-5985			
9	Part	Latch Handle	1	101-5984			
10	Part	Latch Spring (not shown)	2	AW12-19	2		2
11	Part	3/8" UNC x 1" Drilled Hex Socket Cap Screw	2	02-E0249	2		2
12	Weldment	Safety Door Switch Guard	1	101-5972			
13	Part	1/2" UNC x 1-3/4" Hex Socket Head Cap Screw	2	09-2172			
14	Part	1/4" UNC x 1" Hex Cap Screw	1	09-1007		1	1
15	Weldment	Safety Door Switch Mounting / Adjustment Base	1	101-5974			
16	Part	1/4" UNC x 2" Drilled Cap Screw	4	101-6072	4		4
17	Part	1/4" Lock Washer	4	09-5102			
18	Part	Safety Door Switch	1	02-E0190	1		1



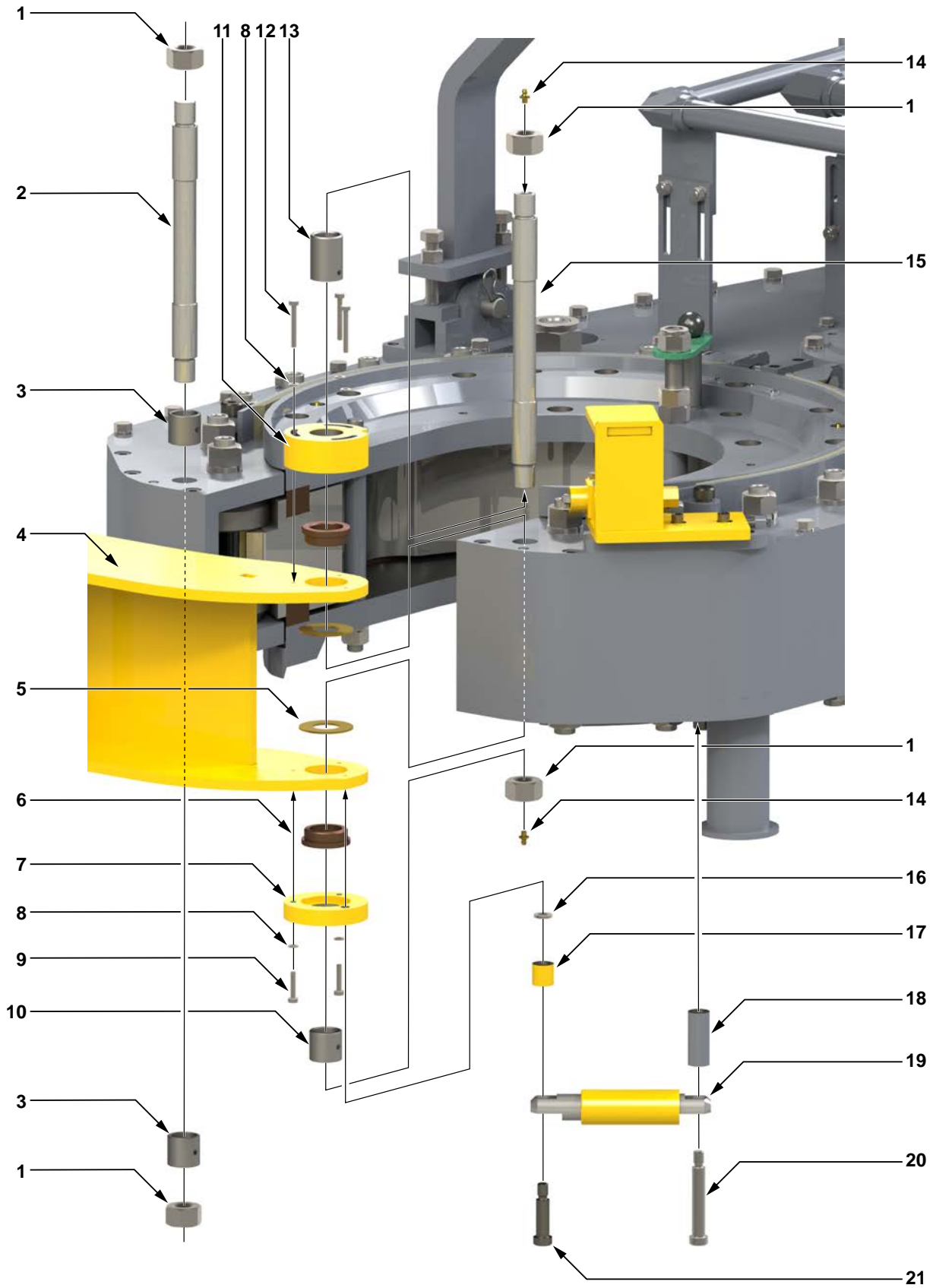


Illustration 5.33: Door Assembly Exploded

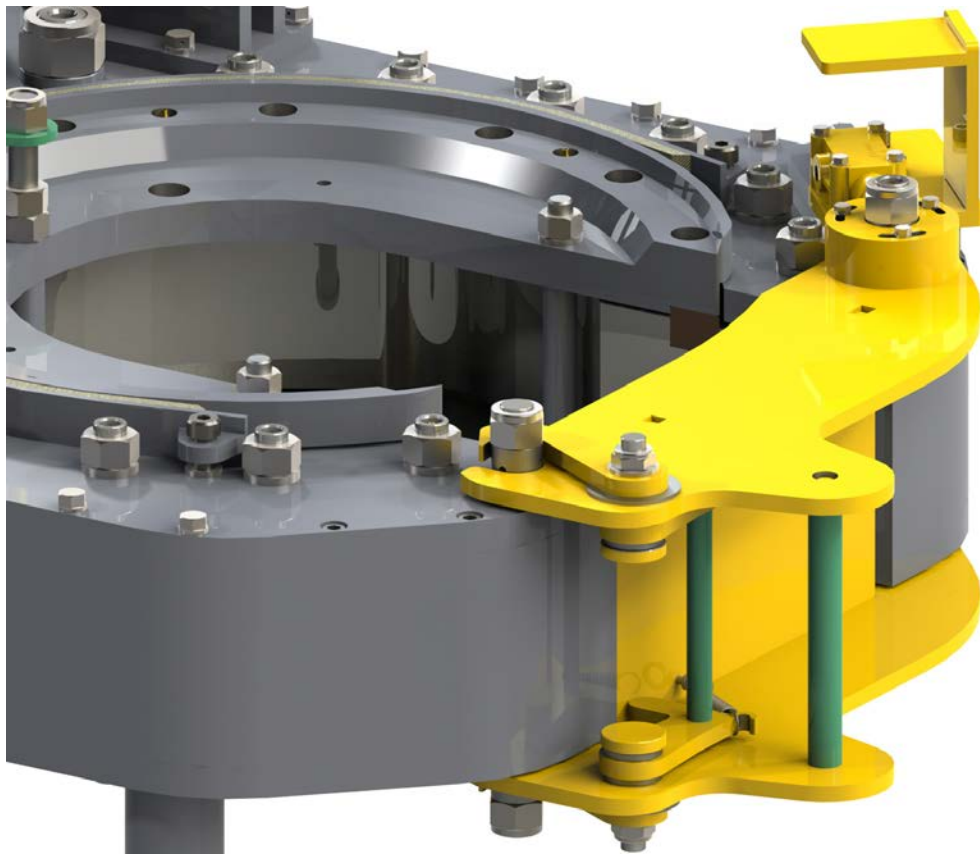


Illustration 5.34: Door Assembly

Item	Type	Description	Qty	Part Number	Recommended Spares (Per Assembly)		
					Critical	One-Year	Overhaul
1	Part	1" UNC Hex Nylock Nut	2	09-5725			
2	Part	Door Latch Post	1	101-6068			
3	Part	Door Latch Spacer	2	101-5991			
4	Weldment	Door Weldment	1	101-5978			
5	Part	Door Bushing	2	101-5990			2
6	Part	Door Shoulder Bushing	4	101-5987			2
7	Part	Bottom Door Pivot Reinforcement	1	101-5989			
8	Part	1/4" Lock Washer	5	09-5102			
9	Part	1/4" UNC x 1-1/4" Hex Bolt	2	09-1009			
10	Part	Bottom Door Pivot Bushing	1	101-5991			1
11	Part	Safety Door Cam	1	101-5988			
12	Part	1/4" UNC x 2" Hex Bolt	3	09-1015			
13	Part	Top Door Pivot Bushing	1	101-5992			
14	Part	1/4" UNF Straight Grease Fitting	2	02-0070			2
15	Part	Door Pivot Shaft	1	101-5976			
16	Part	1/2" Lock Washer	1	09-5110			
17	Part	Door Spring Stop Cylinder Mounting Lug (Short)	1	101-6000			
18	Part	Door Spring Stop Cylinder Mounting Lug (Long)	1	101-5996			
19	Part	Door Spring Stop Cylinder	2	1037-A4-144		1	1
20	Part	5/8" x 1-3/4" Hex Socket Head UNC Shoulder Bolt	1				
21	Part	5/8" x 3-1/4" Hex Socket Head UNC Shoulder Bolt	1				

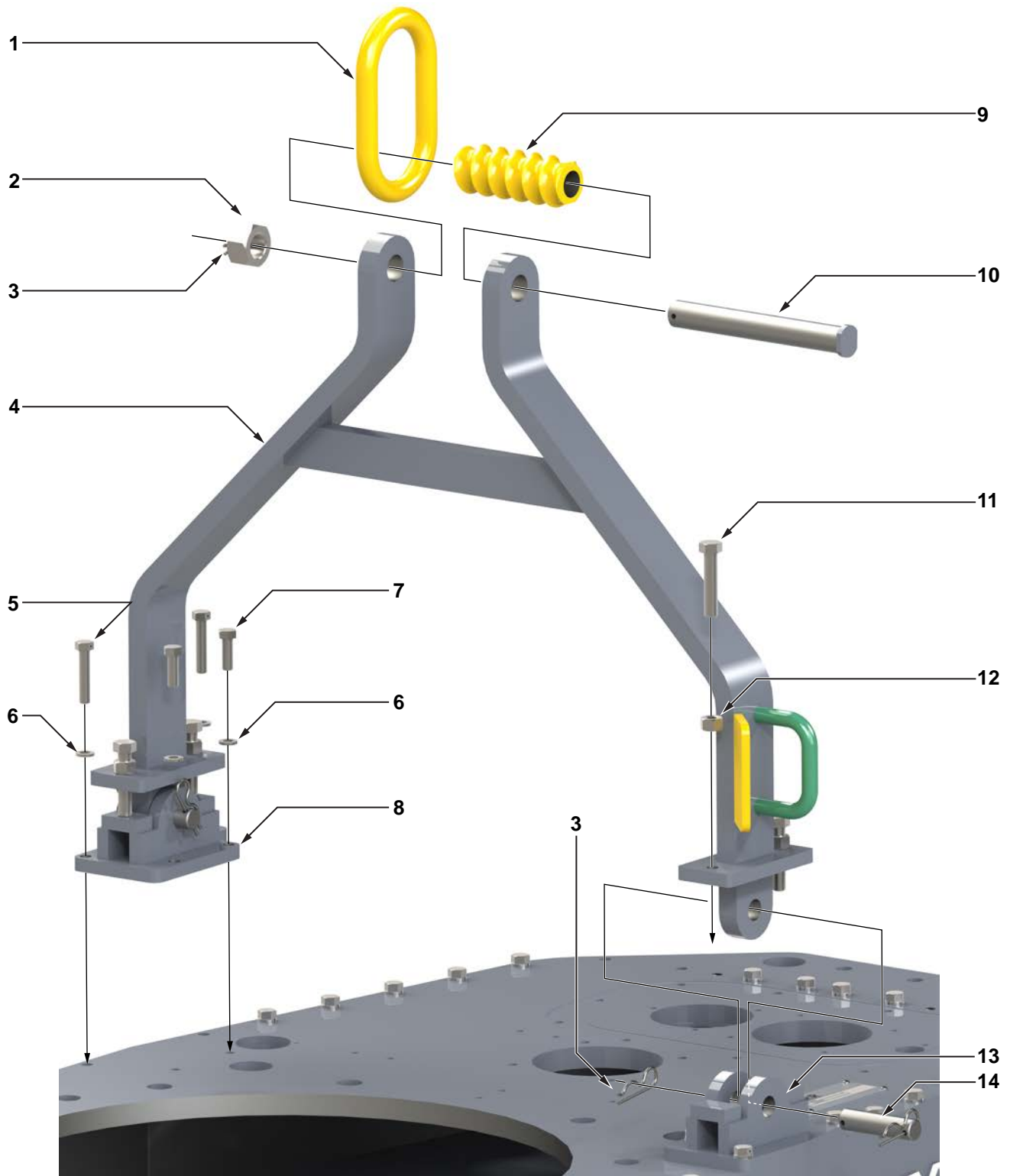


Illustration 5.35: Rigid Sling Exploded



PROPERLY TORQUE ALL FASTENERS SECURING LOAD-BEARING COMPONENTS (CHAIN SLINGS, RIGID SLINGS, BACKUP LEGS).



Illustration 5.36: Rigid Sling

Item	Type	Description	Qty	Part Number	Recommended Spares (Per Assembly)		
					Critical	One-Year	Overhaul
1	Part	Master Link	1	02-9128	1		1
2	Part	1-1/4" UNC Thin Nylock Nut	1	09-1484			
3	Part	R-Clip	5	02-0981		4	5
4	Weldment	Rigid Sling Weldment	1	101-5583			
5	Part	1/2" UNC x 2-1/2" Drilled Hex Bolt	4	101-6071	4		4
6	Part	1/2" Lock Washer	8	09-5108			
7	Part	1/2" UNC x 1-1/2" Drilled Hex Bolt	4	101-6070	4		4
8	Weldment	RH Rigid Sling Bracket	1	101-5595			
9	Part	Adjustment Helix	1	1095-220			
10	Part	Rigid Sling Helix Pin	1	1095-218	1		1
11	Part	5/8" UNC x 3" Hex Bolt (Leveling Bolt)	4	09-1238			
12	Part	5/8" UNC Hex Nut	4	09-5814			
13	Weldment	LH Rigid Sling Bracket	1	101-5581			
14	Part	Rigid Sling Hanger Pin	2	997-955	2		2



**This page intentionally  
left blank**



MOVING GLOBAL ENERGY FORWARD

DRILLING &  
COMPLETIONS

## SECTION 6: TORQUE MEASUREMENT



**This page intentionally  
left blank**



6.A BASIC TORQUE MEASUREMENT

Basic torque measurements are performed using a simple hydraulic measurement system. A hydraulic load cell connects to a calibrated torque gauge through a reinforced flexible hydraulic hose. The torque gauge is factory-calibrated to display accurate torque measurements for a tong or tong and backup assembly with a particular arm length. The arm length is a measurement from the centre of the pipe or casing to the centre of the force being applied to the load cell.

Two load cell options are available. A tension load cell is typically used with a suspended stand-alone tong. This application requires that the load cell be attached to the rear of the tong as part of the restraint line that opposes the force generated when the tong makes up or breaks out a joint. A compression load cell is used in a tong and backup assembly, and is typically located on the rear of the backup between the backup and a stationary frame. The load cell must be located in the centre of the compression force vector generated between the backup and the frame.

Hydraulic force generated by a load cell is transmitted to the torque gauge via a reinforced flexible hydraulic line. The hydraulic force is displayed as torque in units of Ft.-Lbs. The torque gauge has a red “peak torque” indicator that tracks with the torque gauge needle to the point of highest torque, and remains at the point of highest torque until manually reset. Note that every model of tong and tong and backup assembly has a unique arm length, and the torque gauge must be calibrated for that arm length. Torque gauges that are not calibrated for the arm length of the tool in service will not display correct torque. To ensure correct torque measurement, ensure the arm length or “handle” as displayed on your torque gauge matches the arm length of the tool in service as listed on the specifications page of the technical manual.

The images on this page are for illustration purposes only and may not accurately represent the torque gauge and load cell that have been supplied with your equipment.



THE IMAGES DISPLAYED ARE SUPPLIED FOR ILLUSTRATION PURPOSES ONLY



**Illustration 6.A.1: Torque Gauge (For Illustration Purposes Only)**



**Illustration 6.A.2: Tension Load Cell**



**Illustration 6.A.3: Compression Load Cell**

Torque gauges and load cells are supplied as a matched calibrated pair. Substituting one or the other will render the calibration inaccurate even if the actual model numbers appear to be identical. The serial numbers of matching load cell and torque gauges are clearly identified on the calibration certificate. Should you suspect the accuracy of your torque measurements, or wish to replace either component the pair should be returned to the factory for re-calibration before placing into service.



**TORQUE GAUGES AND LOAD CELLS ARE FACTORY-SUPPLIED SUPPLIED AS MATCHED CALIBRATED PAIRS. IF REPLACING EITHER COMPONENT THE LOAD CELL AND TORQUE GAUGE MUST BE RETURNED TO THE FACTORY FOR RE-CALIBRATION BEFORE PLACED INTO SERVICE.**

**6.A BASIC TORQUE MEASUREMENT (CONTINUED:)**

The images on the preceding page are for illustration purposes only and may not accurately represent the torque gauge and load cell that have been supplied with your equipment. Please note that the parts listed in the following table are correct for accurate torque measurement while using the equipment for which this manual is supplied.



**THE TORQUE GAUGE USED IS FULLY DEPENDANT UPON THE ARM LENGTH AND TORQUE RANGE OF THE EQUIPMENT IN USE. THE PART NUMBERS LISTED IN THE FOLLOWING TABLE ARE CORRECT FOR ACCURATELY MEASURING TORQUE USING THE EQUIPMENT FOR WHICH THIS MANUAL IS SUPPLIED.**

Item	Type	Description	Qty	Part Number
	Assembly	45-1/2" Arm - 50K Torque Gauge / Compression Load Cell Assembly	1	10-0041T
1	Part	45-1/2" Arm 60,000 Ft.-Lbs. Torque Gauge	1	10-0041G
2	Part	Tension Load Cell	1	10-0008T
3	Part	Hydraulic Hose	1	02-0069
4	Part	Torque Gauge Flange	1	997-D7-5
5	Part	Tension Load Cell Shackle	1	02-0078



**LOAD CELLS ARE NOT USER SERVICEABLE. ILLUSTRATION 6.A.4 IS PROVIDED FOR INFORMATION PURPOSES ONLY. DAMAGED LOAD CELLS MUST BE RETURNED TO THE FACTORY FOR REPAIR AND RE-CALIBRATION.**

Item	Type	Description
	Assembly	Tension Load Cell, 4.08 in <sup>2</sup>
1	Part	1/4" NC x 1/2" Binding Head Machine Screw
2	Part	Stat-O-Seal
3	Part	O-Ring
4	Part	O-Ring
5	Part	Load Cell Piston
6	Part	Flange Gasket
7	Part	Load Cell End
8	Part	Load Cell Rod
9	Part	Wiper
10	Part	O-Ring
11	Part	Load Cell Body
12	Part	3/8" NC x 3/8" Cup Point Hex Set Screw
Seal Kit		Replacement Seal Kit 4.08 in <sup>2</sup> Tension Load Cell

This is the standard tension load cell supplied by McCoy Global. Contact our sales department for information about optional application-specific tension load cells.

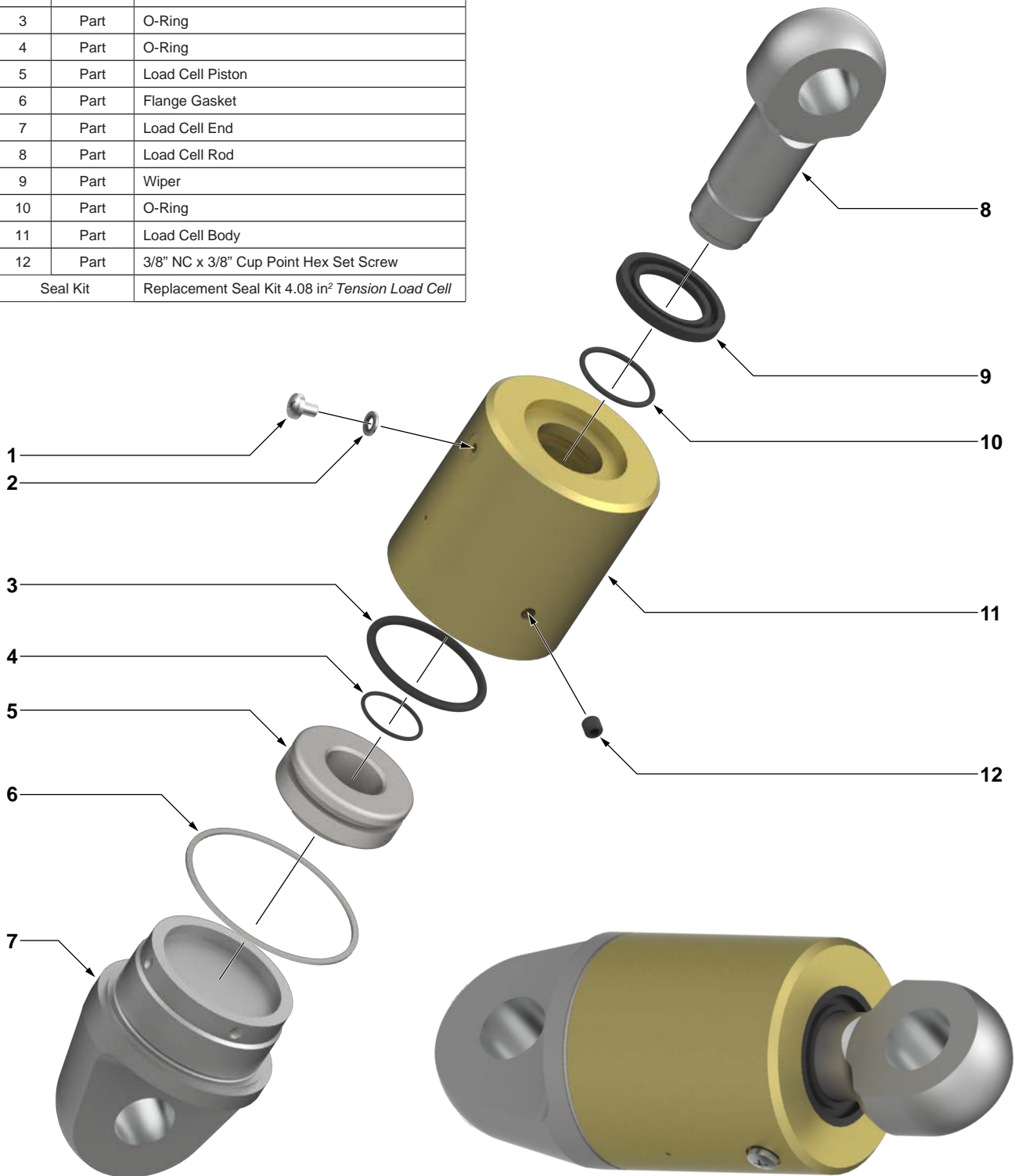
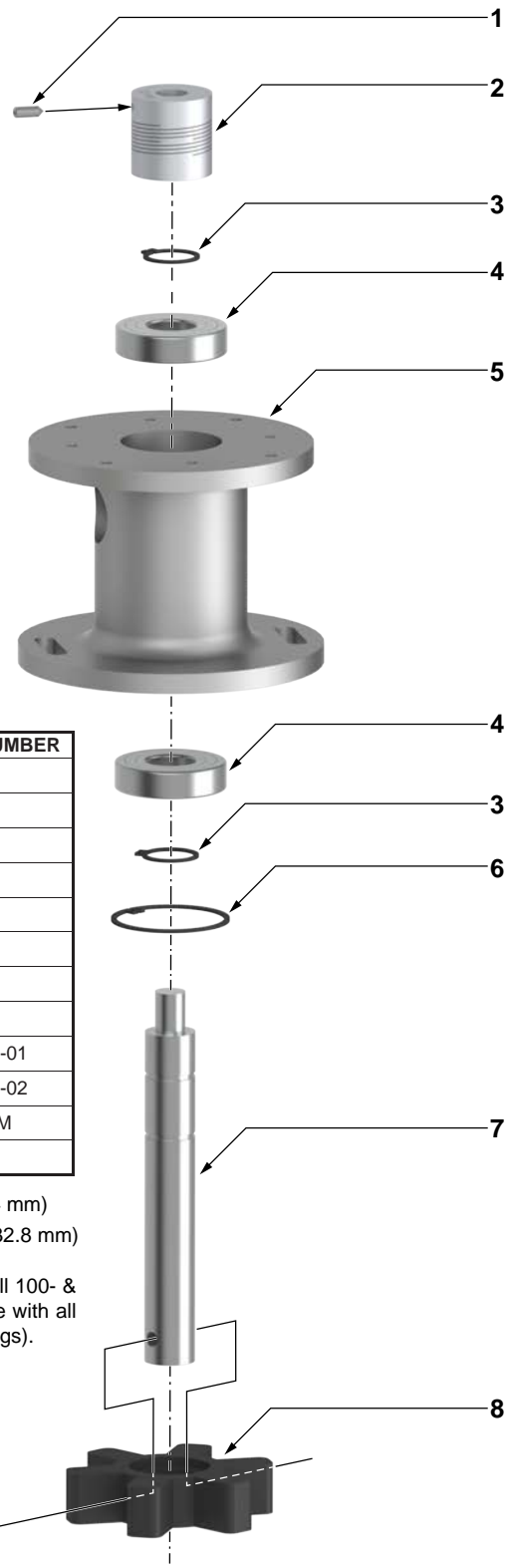
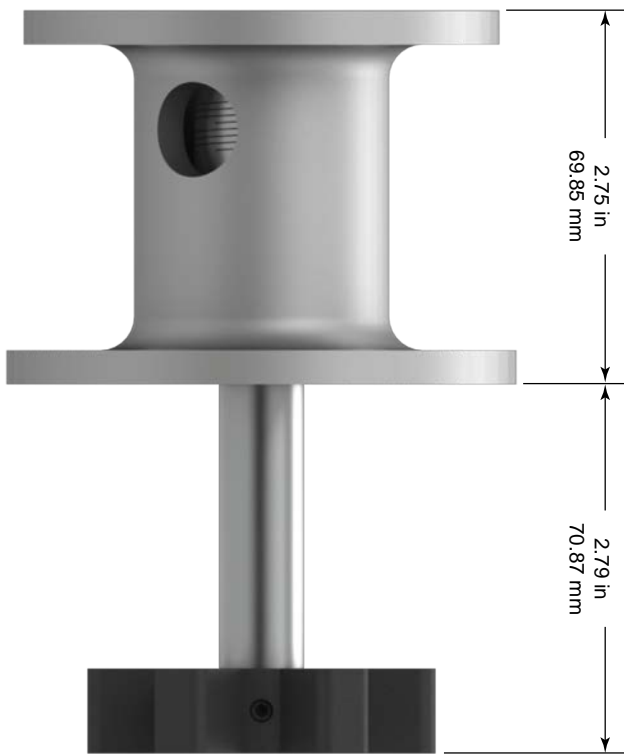


Illustration 6.A.4: Tension Load Cell Exploded



ITEM	TYPE	DESCRIPTION	QTY	PART NUMBER
	Assembly	Encoder mount	1	60-0001
	Assembly	Encoder mount, long encoder shaft	1	60-0001A
1	Part	6-32 x 3/8" hex socket head set screw	4	
2	Part	Helical flexible encoder shaft coupling	1	60-0130N
3	Part	Internal retainer ring	2	1376-13
4	Part	Bearing	2	1376-05
5	Part	Encoder housing	1	1392-104A
6	Part	Internal retainer ring	1	02-0436
7	Part	Encoder shaft, 60-0001 mount	1	1392-103A-01
	Part	Encoder shaft, 60-0001A mount	1	1392-103A-02
8	Part	Encoder gear	1	01-0320A-M
9	Part	10-24 x 1-1/4" hex socket head set screw	1	

Min / max encoder shaft length, encoder # 60-0001: 0.67 in (17 mm) to 0.92 in (23.4 mm)  
 Min / max encoder shaft length, encoder # 60-0001A: 1.04 in (26.4 mm) to 1.29 in (32.8 mm)

Encoder mounts accommodate all standard 100-, 200-, & 500-count encoders, and all 100- & 200-count EX encoders supplied by McCoy Global for use with WINCATT®. For use with all configured McCoy tongs with the exception of models 80-0001-X (SL4500 "slim" tongs).

Illustration 6.A.6: Turn Counter Encoder Mount Exploded

## 6.B TROUBLESHOOTING

Under normal operating conditions, and with proper maintenance, the torque gauge and load cell system are designed to give lasting trouble-free performance. Faulty indication on the gauge will very often define a fault within the gauge.



**IF TROUBLESHOOTING REVEALS THAT THERE IS INSUFFICIENT FLUID IN THE SYSTEM, BEFORE RECHARGING, CHECK THAT ALL SYSTEM COMPONENTS ARE FREE FROM DAMAGE. THIS WILL ENSURE THAT FLUID LOSS WILL NOT CONTINUE AFTER RELOADING**

1 SYMPTOM: NO INDICATION ON TORQUE GAUGE	
POSSIBLE PROBLEM	SOLUTION(S)
Hydraulic hose is obstructed	Check hydraulic hose for kinks
	Replace hydraulic hose
Loss of hydraulic fluid	Recharge hydraulic fluid (see Section 6.C). NOTE: Ensure any breaches in the hydraulic system between the load cell and torque gauge are repaired to prevent further fluid loss.
Internal mechanism of torque gauge is damaged	Replace gauge
2 SYMPTOM: GAUGE INDICATION UNEXPECTEDLY HIGH	
POSSIBLE PROBLEM	SOLUTION(S)
Excessive hydraulic fluid	Completely drain hydraulic fluid from torque gauge/load cell system. Recharge following the procedure in Section 6.C
Internal mechanism of gauge is damaged	Replace gauge
Incorrect torque gauge in use (not part of the original torque gauge/load cell pair)	Replace gauge with gauge properly calibrated for the load cell in service
3 SYMPTOM: GAUGE INDICATION UNEXPECTEDLY LOW	
POSSIBLE PROBLEM	SOLUTION(S)
Insufficient hydraulic fluid	Recharge hydraulic fluid (see Section 6.C). NOTE: Ensure any breaches in the hydraulic system between the load cell and torque gauge are repaired to prevent further fluid loss
	Check hydraulic hose for kinks
Obstruction in hydraulic hose	Replace hydraulic hose
Snub line not at right-angle to tong handle	Check angle of snub line and correct if necessary
Internal mechanism of gauge is damaged	Replace gauge
Incorrect torque gauge in use (not part of the original torque gauge/load cell pair)	Replace gauge with gauge properly calibrated for the load cell in service
4 SYMPTOM: GAUGE INDICATION IS ERRATIC OR SLUGGISH	
POSSIBLE PROBLEM	SOLUTION(S)
Insufficient hydraulic fluid in torque measurement section	Recharge hydraulic fluid (see Section 6.C). NOTE: Ensure any breaches in the hydraulic system between the load cell and torque gauge are repaired to prevent further fluid loss
Loss of damping fluid in torque gauge	Top up or refill damping fluid (NOTE: Ensure leakage points in gauge are identified and repaired to prevent further loss of damping fluid)
Air bubbles in hydraulic fluid in the torque measurement system	Bleed air from load cell and torque gauge and top up fluid (if necessary) as per Section 6.C
Internal mechanism of gauge is damaged	Replace gauge

## 6.C PERIODIC INSPECTION AND MAINTENANCE



**ONLY QUALIFIED, DESIGNATED PERSONNEL ARE PERMITTED TO PERFORM MAINTENANCE ON THE TORQUE MEASUREMENT SYSTEM.**

**6.C.1 Inspection**

The torque measurement system supplied with your equipment is designed and built to provide years of trouble-free service with minimum maintenance. Periodic inspections of the load cell, hydraulic lines and fittings are recommended in order to keep the system in top operating condition. A thorough inspection should be made at each rig-up.

**6.C.2 Fluid Recharge**

Recharge hydraulic system with W15/16 fluid through the check valve on the torque indicating gauge. Recharging must only be performed when there is no load on the load cell. Refer to the illustrations on pages 6.3 & 6.4 for guidance if required.

- a. Place the torque indicating gauge higher than the load cell. Remove the brass 1/4" cap from the fitting on the check valve on the top of the gauge.
- b. Connect the hand pump to the check valve fitting.
- c. Elevate the load cell so it is higher than the torque gauge and hand pump.



**UN-CONTAINED SPILLAGE OF THE HYDRAULIC FLUID IN THIS SYSTEM MAY CONTRAVENE GOVERNMENTAL ENVIRONMENTAL REGULATIONS, OR THE ENVIRONMENTAL REGULATIONS AND POLICIES OF YOUR COMPANY. MCCOY GLOBAL HIGHLY RECOMMENDS PLACING YOUR LOAD CELL IN A CONTAINMENT BASIN BEFORE PROCEEDING WITH THE BLEEDING & REFILLING PROCESS.**

- d. Fill hand pump bowl with W15/16 hydraulic fluid.



**MAINTAIN GREATER-THAN HALF FULL FLUID LEVEL IN THE HAND PUMP BOWL TO AVOID PUMPING AIR INTO THE SYSTEM. DO NOT ALLOW THE LEVEL TO FALL BELOW ONE-HALF FULL**

- e. Remove the vent plug screw and Stat-O-Seal (Items C and D on Illustration 6.A.4, or item H on Illustration 6.A.5) to allow trapped air to escape.
- f. Pump fluid into the system until no more air is seen escaping from the vent port.
- g. Replace the vent plug screw and Stat-O-Seal and tighten securely.
- h. Remove load cell from containment vessel and wipe clean. Reclaim the hydraulic fluid (if it is clean) or dispose of all waste materials according to governmental or your company's proscribed environmental protection regulations.
- i. Disconnect the hand pump from the torque gauge.
- j. Replace the brass cap on the torque gauge check valve fitting.

**6.C.3 Reference Checking Your Torque Measurement System**

The following steps define a process for determining if your torque measurement system is correctly measuring and indicating within an expected range. This procedure is best suited for performing in a shop or location removed from the drill floor, within range of a crane. This is a reference check and not a calibration. Calibrations must be performed at an authorized calibration facility.

Tension Load Cell

- a. Locate a known weight in the range of approximately 500 to 1000 lbs (227 to 455 kg), and move the weight next to the tong and backup assembly.
- b. Remove the tension load cell from the tong, but do not disconnect from the torque gauge.
- c. Suspend the load cell, piston side up, from a crane capable of supporting the known weight in Step 3a.
- d. Connect the rod side of the load cell to the known weight, and use the crane to hoist the weight from the surface to be suspended freely.

Continued on next page...

**6.C.3 Reference Checking Your Torque Measurement System (Continued):**

Tension Load Cell (continued):

- e. Perform a simple calculation to determine the expected indication on the torque gauge based on the known hoisted weight. This is a calculation that must be performed using imperial units (eg., pounds and feet). The calculation is: [KNOWN WEIGHT] x [ARM LENGTH (in feet)]. For example, if the arm length is 36 inches and the hoisted weight is 1000 lbs the calculation is:

$$1000 \times (36/12) = 3000$$

Therefore, the expected indication on the torque gauge should be 3000 lbs-ft.

**6.C.4 Repair And Calibration**

Return the load cell and indicator gauge to the authorized repair facility for repairs and calibration.





**This page intentionally  
left blank**



## SECTION 7: HYDRAULIC COMPONENT INFORMATION

The manufacturer information contained in this section has been obtained from publicly available web sites and has been provided for information purposes only. McCoy Global does not guarantee the accuracy of the information contained in this section. All original copyrights claimed by the manufacturer(s) apply.



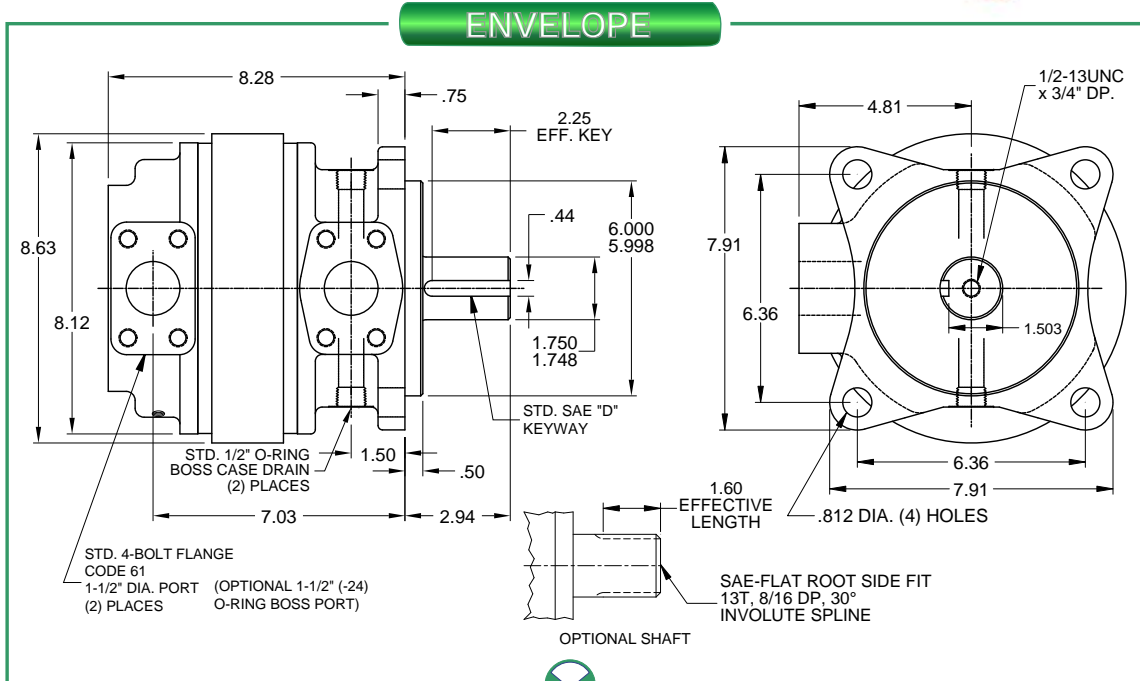
37 series

**POWER to be the Best!**

**MOTOR SELECTION GUIDE**

**Features of the 37 Series Standard Motor:  
Standard Motor - 3000 PSI (Code 61)**

- Six fixed displacement motors ranging from 12 in<sup>3</sup> to 37 in<sup>3</sup>.
- 4-Port double motors from 24 in<sup>3</sup> to 74 in<sup>3</sup> allowing for two-speed operation with external valving.
- Starting and stall torques equal to 90-94% of theoretical torque.
- Speed to 1,000 RPM continuous.
- Up to 175 HP continuous.
- Conforms to SAE 'D' mounting specification.
- Weighs 106 lbs.



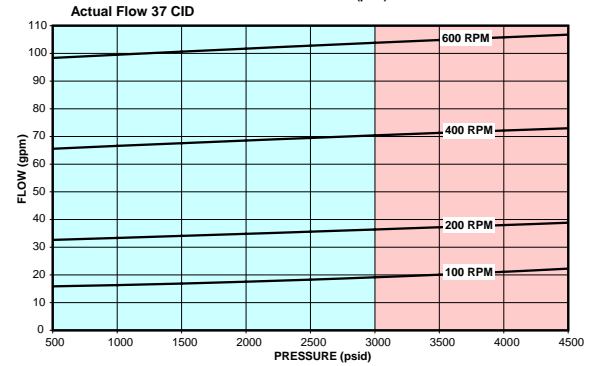
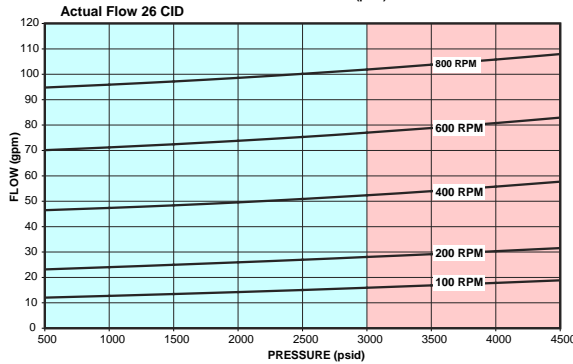
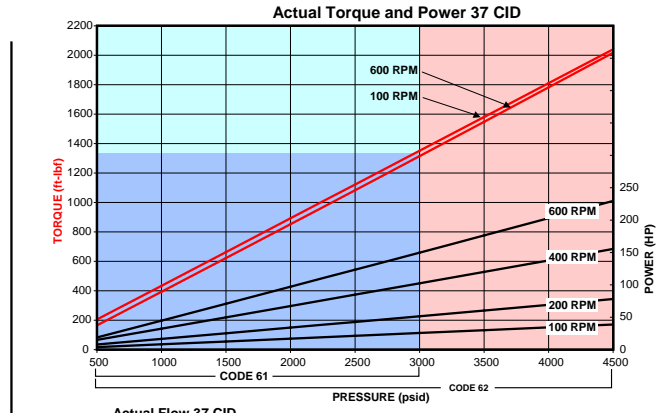
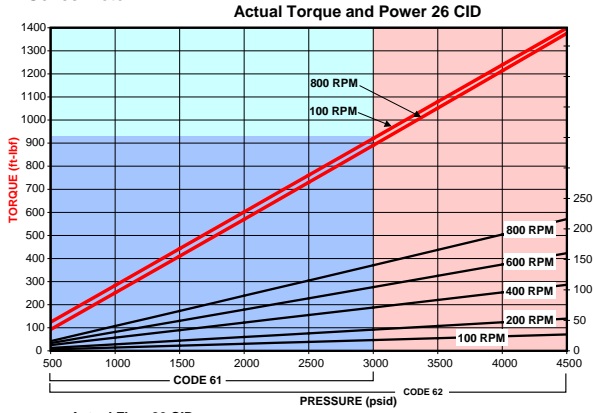
Made in USA

PUBLICATION DS371005 3/04

## Performance Data

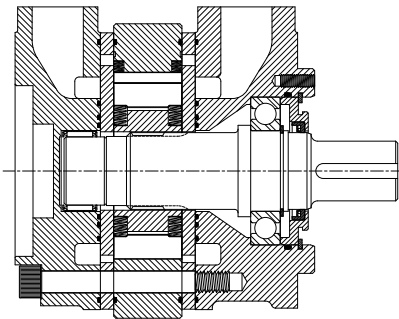
Charts shown are for 26 and 37 CID. See website at [www.rineer.com](http://www.rineer.com) for additional charts. Performance data obtained at 140°F with ISO 46 (DTE 25). Code 61 and 62 data shown. Code 62 extended data applies only to Code 62 High Pressure Series motor.

**VANE CROSSING VANE** - With its vane crossing vane design, the Rineer motor produces much higher volumetric and mechanical efficiencies than is possible with a standard vane type design. This design provides a sealing vane between stator cavities to improve mechanical and volumetric efficiencies.



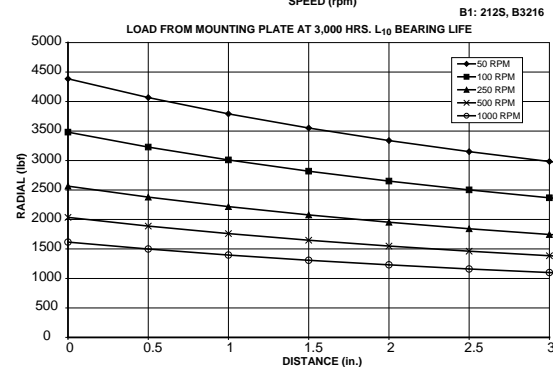
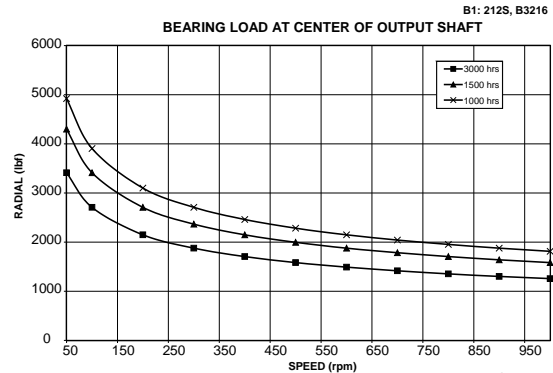
Performance of the Rineer 37 Series Motor has been greatly enhanced by internal design changes resulting in a pressure balanced rotating group. Benefits of this new design include reduced cross port leakage and increased efficiency as well as greater reliability at higher pressures. This patented design has been in effect for over 5 years.

### Bearing Data - Standard Motor



**BEARING LOADING** - The bearings in the 37 Series can accept radial load per the radial capacity charts to the right. Thrust loading is not recommended for the standard motor. For thrust-type applications, see the thrust capable motor bearing chart on the opposite page.

**HORSEPOWER LIMITATION** - Maximum horsepower limitation may vary with different applications. When using the 37 Series standard motor above 175HP, consult a Rineer Application Engineer.



**Envelope - Double Key**

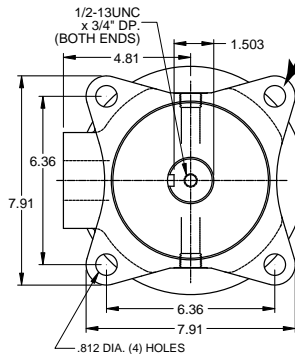
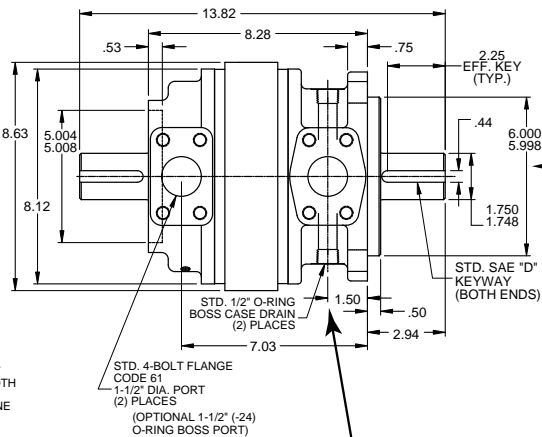
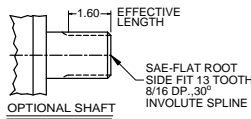
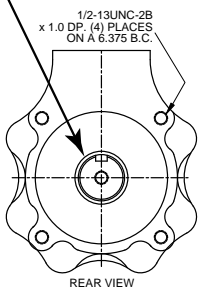
**STARTING AND STALL TORQUE**

The Rineer motor produces torque curves which are virtually flat, with starting and stall torque equal to approximately 90-94% of theoretical torque.

**MORE POWER STROKES PER REVOLUTION**

The 37 Series has four stator cavities and 10 rotor vanes. Each rotor vane works in each stator cavity once per revolution, which results in 40 power strokes per revolution. This helps produce higher mechanical efficiency and flatter torque curves.

**SEALS** - Viton shaft seals are supplied standard. Buna N static seals are supplied standard. Viton static seals may be ordered as an option.



**ROTATION** - The 37 Series motor rotates equally well in either direction and smoothly throughout its entire pressure and speed range. Looking into the end of the shaft, rotation is clockwise when oil is supplied to the port nearest the shaft.

**FLUID** - We suggest premium grade fluids containing high quality rust, oxidation and foam inhibitors, along with anti-wear additives. For best performance, minimum viscosity should be maintained at 100 SSU or higher. Fluid temperature should not exceed 180°F. Elevated fluid temperature will adversely affect seal life while accelerating oxidation and fluid breakdown. Fire resistant fluids may be used with certain limitations. Contact Rineer for additional information.

**FILTRATION** - 25 micron minimum.

**CASE DRAIN AND CROSS PORT LEAKAGE**

The combined case drain and cross port leakage of the 37 Series motor is approximately 1 GPM per 1,000 PSI. This will vary with the oil viscosity and internal clearance selection.

**SAE "D" MOUNTING** - The 37 Series mounting configuration conforms to SAE "D" 4-bolt specification, with the exception of the undercut on the splined shaft. The mounting position is unrestricted. The shafts, pilots, and mounting faces should be within .002 TIR.

**CASE DRAIN** - The 37 Series motor requires an external case drain. Two case drain ports are supplied; use the port at the highest elevation. We recommend case pressure of less than 35 PSI.

**CASE DRAIN CIRCULATION** - Fluid should be circulated through the two case drain ports when a temperature differential exists between the motor and the system in excess of 50°F. *Should this occur, contact a Rineer Application Engineer.*

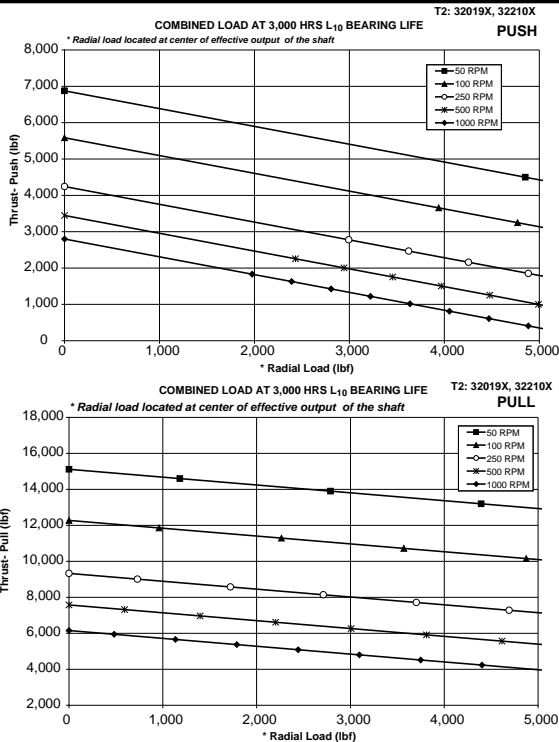
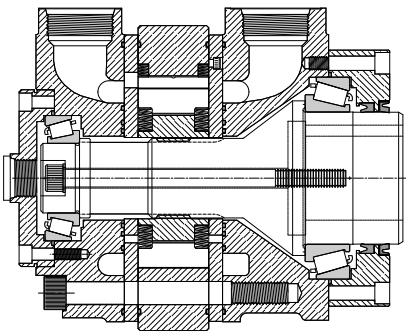
**Bearing Data - Thrust Capable**

**BEARING LOADING THRUST CAPABLE**

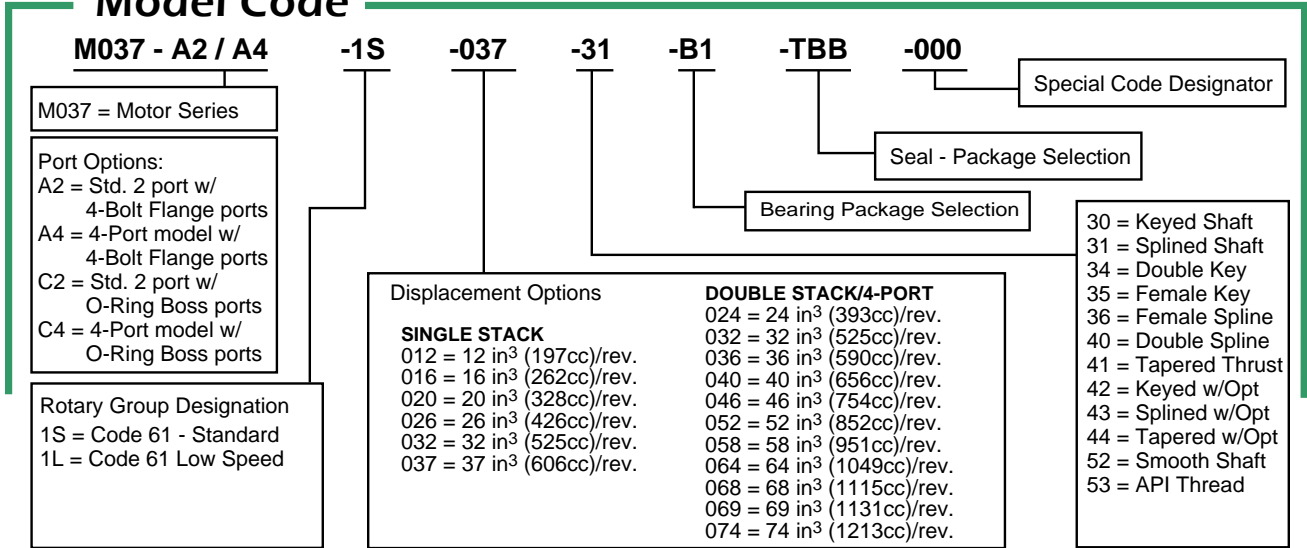
The bearings in the 37 Series Thrust capable motor can accept thrust and radial load per the push/pull capacity charts to the right. Thrust loading is allowed up to the parameters indicated on the charts with shaft configurations including standard keyed and splined as well as the female shaft type shown below. For applications not requiring thrust, see the standard motor bearing charts on the opposite page.

**HORSEPOWER LIMITATION**

Maximum horsepower limitation may vary with different applications. When using the 37 Series standard motor above 175HP, consult a Rineer Application Engineer.



### Model Code



### Applications



**For durable hydraulic motors that meet your demands, specify Rineer.**  
 For over 35 years, we have specialized in only one thing - engineering the right motor for your needs. Rineer delivers the performance you can count on.

Visit our website at [www.rineer.com](http://www.rineer.com)

#### Limited Warranty Policy

Rineer Hydraulics, Inc. warrants that, at the time of shipment to Purchaser, our product will be free of defects in the material and workmanship. The above warranty is LIMITED to defective products returned by Purchaser to Rineer Hydraulics, Inc., freight prepaid within four hundred and fifty-five (455) days from date of shipment, or one (1) year from date of first use, whichever expires first. We will repair or replace any product or part thereof which is proved to be defective in workmanship or material. There is no other warranty, expressed or implied, and in no event shall Rineer Hydraulics, Inc. be liable for consequential or special damages. Dismantling the product, operation of the product beyond the published capabilities or for purposes other than that for which the product was designed, shall void this warranty.





**This page intentionally  
left blank**

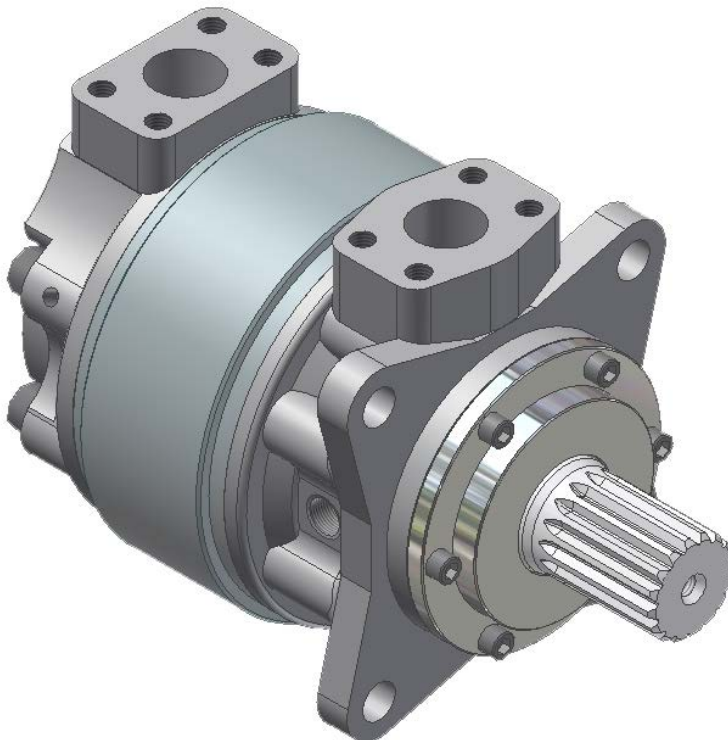
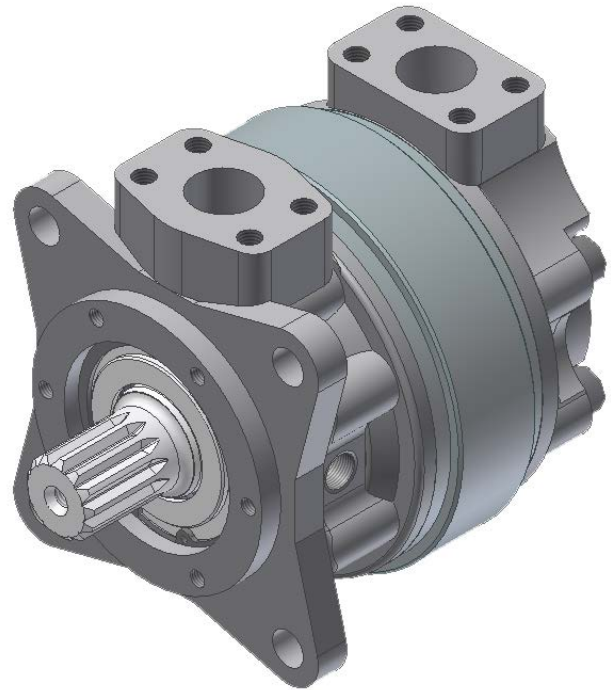




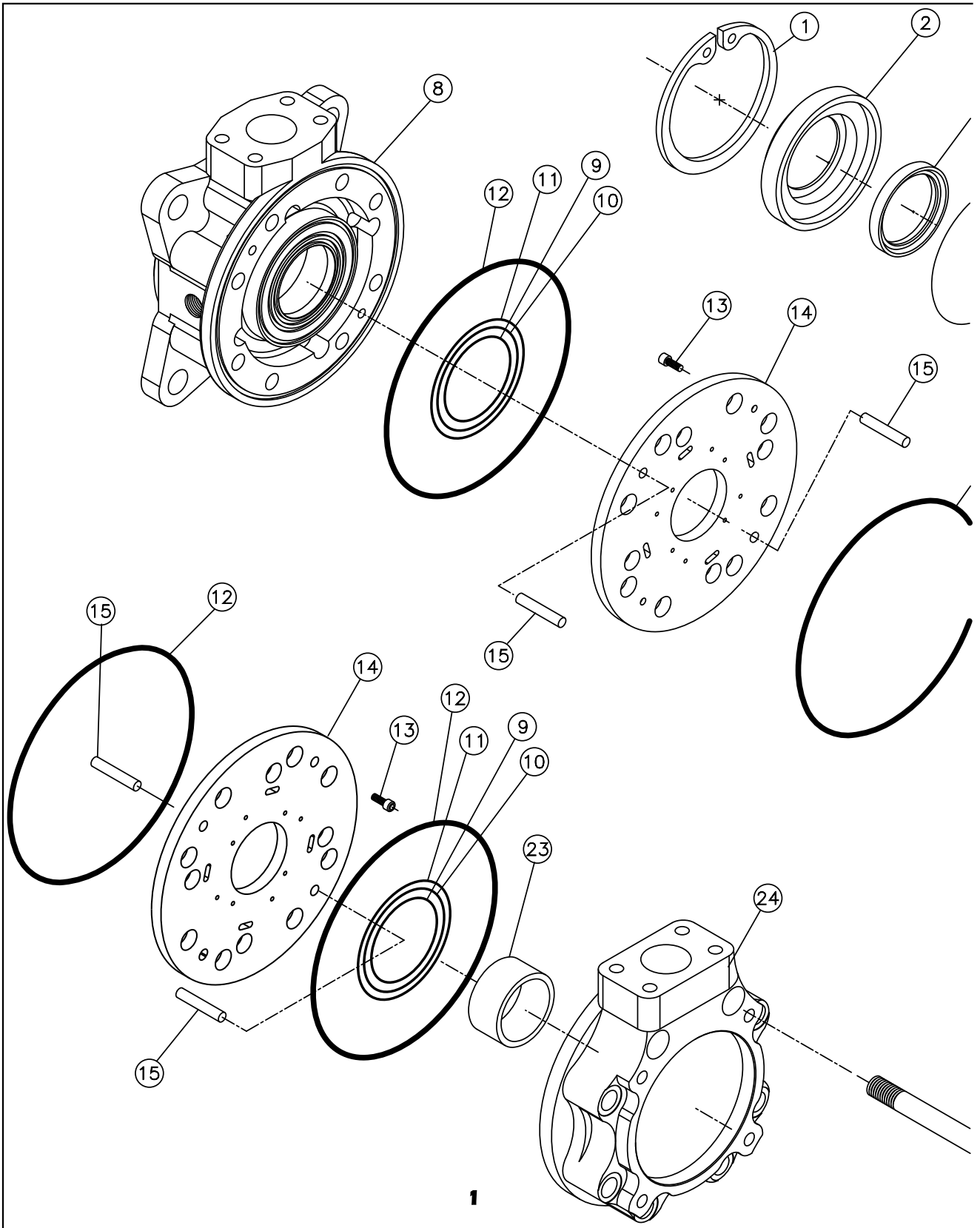
# Repair Manual

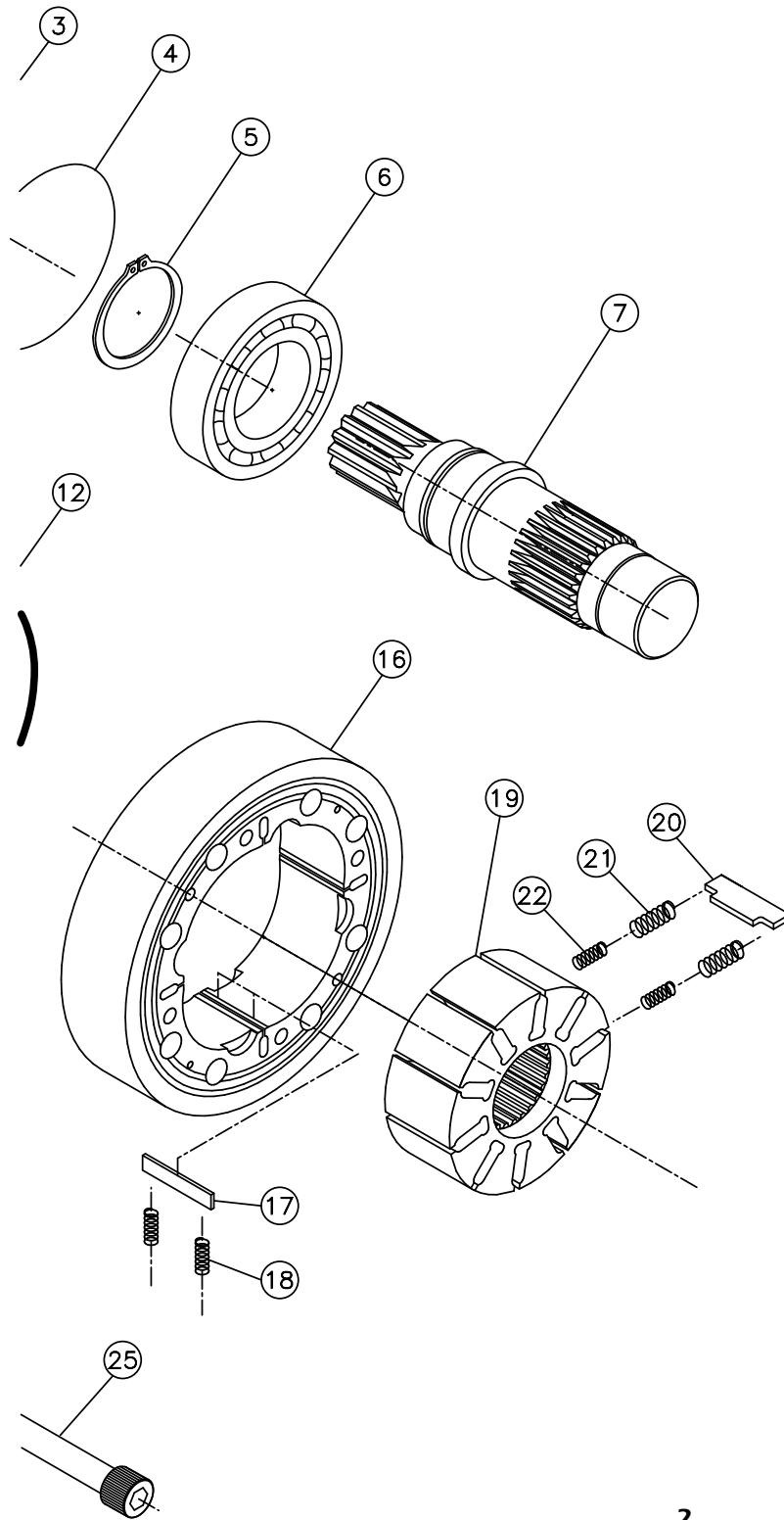
37 Series 57 Series

**37** —————



————— **57**





SERIES 37 EXP. VIEW, STD. "A" STYLE			
ITEM	PART NO.	DESCRIPTION	QTY
1	0370111	SEAL PLATE SNAP RING	1
2	0370152	SEAL PLATE	1
3	0370175	SEAL, SHAFT, TCN	1
4	0370114	O-RING, SEAL PLATE	1
5	0370730	SNAP RING, BEARING	1
6	0370711	BALL BEARING	1
7	0370702	SHAFT, SPLINED	1
	0370701	SHAFT, KEYED	1
8	0371123	FRONT HOUSING, A, PC	1
9	0370811	O-RING, THERMAL, INNER	2
10	0371829	O-RING, THERMAL, MIDDLE	2
11	0370810	O-RING, THERMAL, OUTER	2
12	0370610	O-RING, MAIN	4
13	0150620	PLATE SCREW	4
14	0370618	PLATE, TIMING, PC	2
15	0370431	DOWEL PIN	4
16	0370400	STATOR, GA 37	1
	0370401	STATOR, GA 32	1
	0370402	STATOR, GA 26	1
	0370403	STATOR, GA 20	1
	0370404	STATOR, GA 16	1
	0370406	STATOR, GA 12	1
17	0150410	STATOR VANE	4
18	0370420	STATOR VANE SPRING	8
19	0370300PC	ROTOR	1
	0370300PL	ROTOR	1
20	0370313PC	ROTOR VANE, S	10
	0370316PL	ROTOR VANE, L	10
21	1250320	ROTOR VANE SPRING, OUTER	20
22	1250321	ROTOR VANE SPRING, INNER	20
23	0370720	NEEDLE BEARING	1
24	0370883	REAR HOUSING, A, PC	1
25	0370901	BOLT	8

**WARNING:** RINEER RECOMMENDS FOLLOWING ALL STANDARD SHOP SAFETY PRACTICES SPECIFICALLY INCLUDING WEARING OF EYE PROTECTION.

**Removal of 37 Series Seal Carrier Plate**



1) Remove snap ring.

**WARNING:**  
Use caution when removing snap ring. If released accidentally, it can become an airborne hazard.



(Remove only as necessary) Bearings from both shafts can now be removed in the following manner:

- 37 Series
- □ 1) Remove snap ring from □ shaft.
- □ 2) Press shaft out of bearing.
- 57 Series
- □ 1) Unfold tab on lock washer.
- □ 2) Unscrew lock nut with hook □ style spanner wrench.
- □ 3) Press shaft out of bearing.



1) Pry out shaft seal plate □ with two screwdrivers.

2) Remove seal plate o- □ ring from groove in □ bearing bore.

**NOTE:**  
The shaft seal on a std. □ motor is pressed in and □ can be removed in the □ reverse manner.

**Removal of Front Housing and Rotating group**



Both the 37 and 57 motors should be positioned as shown in a suitable mount to hold the unit during main bolt removal and subsequent disassembly. To ensure proper orientation during assembly, use a laquer paint pen to mark a line down the side of the motor.

**Removal of 57 Series Seal Carrier Plate**



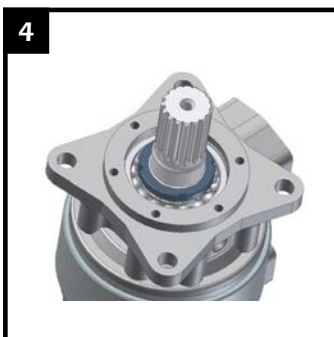
1) Loosen and remove 6 each 3/8-16 bolts.

2) Lift up on the seal plate. Protect the shaft seal from being cut by the keyway (keyed shaft) by placing a thin strip of metallic tape over the shaft. Smooth any burrs that may tear or snag the seal.



Loosen and remove the eight 5/8-11 main bolts. Any bolt heads showing heavy corrosion or signs of rounding of the hex form should be replaced.

**Shaft Disassembly**



A 1/2-13 tapped hole is included in the end of the 37 and 57 series shafts. A slide hammer shaft puller can be attached using this tapped hole in order to remove the shaft from the motor.

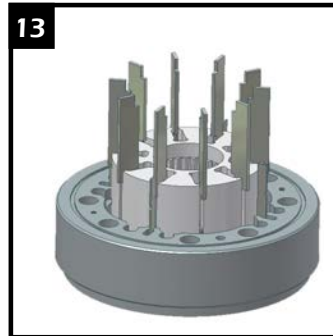


Remove rear housing as shown. Remove o-rings from housing and dowel pins from the rotating group.

**WARNING:** RINEER RECOMMENDS FOLLOWING ALL STANDARD SHOP SAFETY PRACTICES SPECIFICALLY INCLUDING WEARING OF EYE PROTECTION.



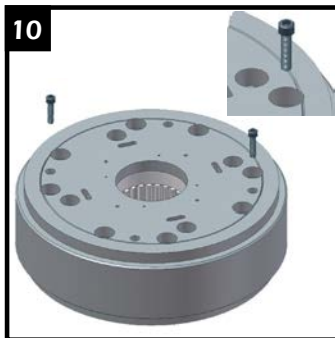
Remove rotating group from front housing as shown. Place the rotating group on a clean surface for disassembly and inspection. Remove dowel pins and o-rings from the housing.



1) Remove the rotor.  
2) Remove both the rotor and the stator vanes.  
**NOTE:** On motors manufactured prior to 1987, rotor vane slots and rotor vanes should be numbered so that vanes can be reassembled in the same vane slot.  
3) Separate parts and rinse in solvent tank.

**Disassembly of Rotating group**

**Inspection and Replacement of parts**



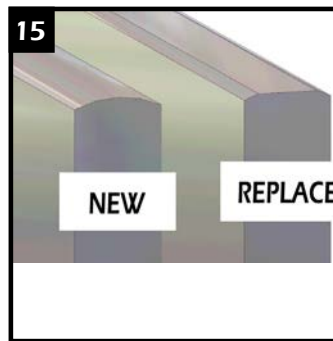
1) Place cartridge on any object which will hold it off the table.  
2) Remove two each 10-32 plate screws.  
3) Remove timing plate.



Inspect all parts and replace any parts which obviously show excessive wear or damage. We recommend changing all springs and seals whenever the motor has been disassembled.



Using a small screwdriver or pick, remove o-ring and all rotor and stator springs.  
**Note:** Some 57 series rotating groups may contain additional "wave" springs in the stator vane slot (see inset).



**VANES:**  
Normal wear results in slight flattening of vane tips which does not impair motor performance. Replace vane if radius is reduced by 50%. Clearance between the rotor vane and rotor vane slot varies with the vane selection. The design allows the vane to "lean" slightly in the slot, providing the required mechanical seal.



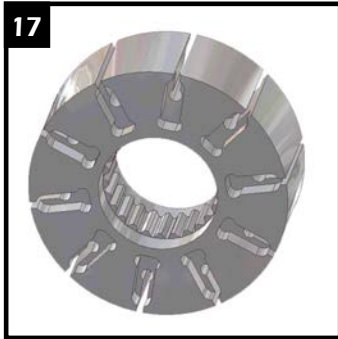
1) Replace plate on rotor/stator cartridge.  
2) Turn rotor/stator cartridge over.  
3) Repeat steps 10 & 11.



**PLATES:**  
Normal wear results in marking or polishing of the timing plate surface, which does not impair motor performance. Replacement of the timing plate is required if any smearing, galling, or heat cracks are present.

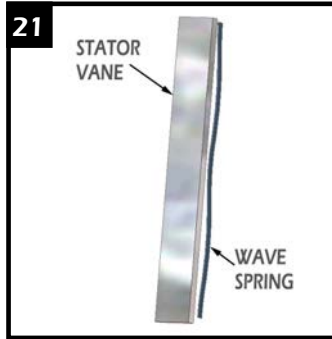


**WARNING:** RINEER RECOMMENDS FOLLOWING ALL STANDARD SHOP SAFETY PRACTICES SPECIFICALLY INCLUDING WEARING OF EYE PROTECTION.



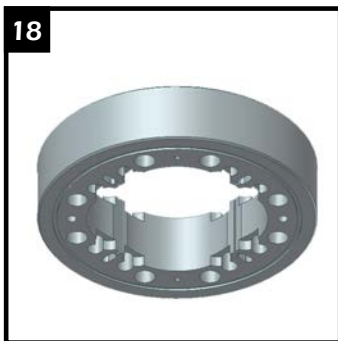
17

**ROTOR:** Normal wear results in polishing of rotor faces which does not impair motor performance. Examine the rotor vane slots closely. Polishing down in the slots is normal, but if there is any indication of a "pocket" forming in the wall of the slot, the rotor should be replaced.



21

Wave springs in the 57 series do not need to be replaced. Certain model codes do not contain wave springs, while other model codes may contain two per vane. Place the stator vane and wave spring in the stator vane slot simultaneously. Note orientation as shown. Do not let the coil spring loop catch between the wave spring and vane.



18

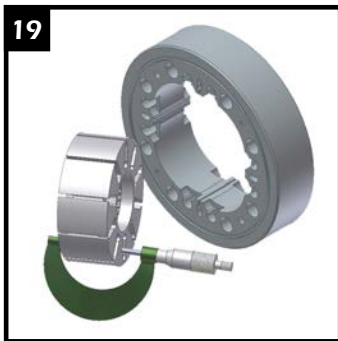
**STATOR:** Normal wear results in polishing of cam form which does not impair motor performance. Noticeable wear may be apparent along the corner of one side of the stator vane slot. This does not necessarily require replacement of the stator, but may slightly affect volumetric efficiency.

**Assembly of Motor**



22

Using a medium India honing stone, lightly dress all machine surfaces to remove any raised metal or burrs. Pay particular attention to the front and rear housing machined faces. Rough handling can cause raised surfaces near the O.D. of the housings which will prevent proper seating of the timing plates to the machined surfaces of the housing. NOTE: The pedestal surface (center of the front and rear housing containing two or three o-rings) is .002-.003 below the outer machined surface. Dress these surfaces independently.



19

Measure the rotor and stator length to the fourth decimal point and supply measurement when ordering rotor, stator, or vanes.



23

Assemble the motor by reversing the previous procedures. Insure that the main body and pedestal o-rings are held in place by using an adequate amount of grease in the o-ring grooves. Line up the housings and rotating group with the paint line made on the motor in step 6.

**Assembly of Rotor / Stator Cartridge**



20

1) Reverse the procedures in steps 13, 12, 11, and 10. Before installing timing plate onto completed sides of rotating group, pour a small amount of hydraulic oil onto rotor surface.  
 2) NOTE: Make sure that the radiused edge of each stator vane points to the rotor and the radiused edge of each rotor vane points to the stator.  
 3) NOTE: Make sure springs are seated in the bottom of the spring pocket in both the rotor and stator.  
 NOTE: Do not allow the coil of any spring catch on the edge of the rotor or stator vanes.



24

Grease the threads of the 5/8-11 bolts and insert into motor. Set torque wrench to 200 ft. lbs. and tighten in a star pattern. Install shaft, seal plate and snap ring in reverse order of previous procedures. Rotate shaft to insure no binding is present.

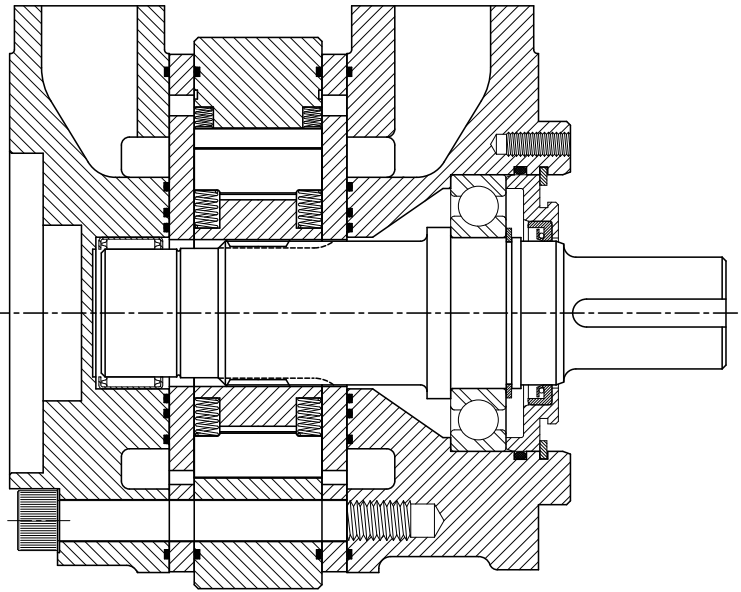
**Information:**

Bolt Torque -  
 Main Bolts (5/8-11): 200 ft. lbs.  
 Seal Plate (3/8-16)  
 (57 series only): 45 ft. lbs.  
 Grease used for bolt threads  
 and o-ring retention:  
 Pennzoil 707L RED  
 Shaft seal assembly lube:  
 Mobilgrease special  
 with Moly

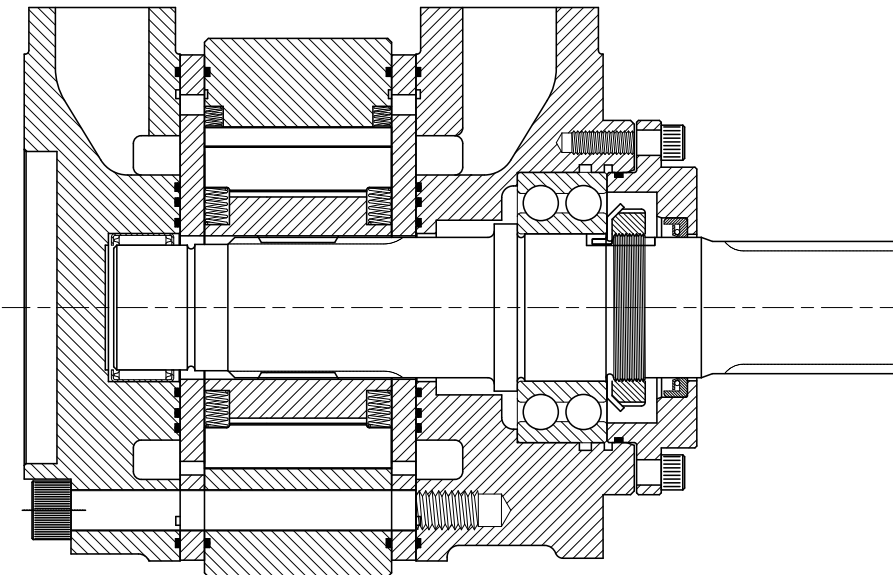
Seal Kits:

Standard 37 series seal kit  
 #0370973  
 Standard 37 thru-key seal kit  
 #0370962  
 Standard 57 series seal kit  
 #0370963

**37**



**57**



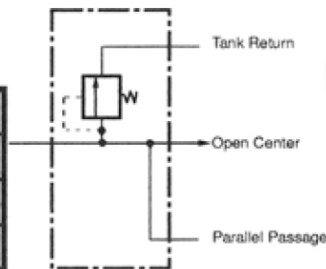


# Inlets (2500 psi)

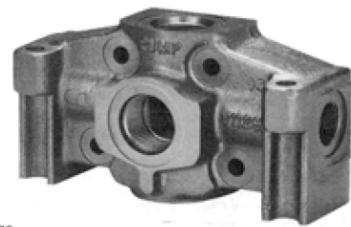
## End Inlet

Code	End Port	Top Port
DVA35-A440	1" NPT	1" NPT
DVA35-A880	SAE-16	SAE-16
DVA35-A980	SAE-20	SAE-16
DVA35-A000	NON-PORTED HOUSING	

NOTE: Inlets are machined for a main R/V or R/V plug and are furnished with plastic closures. See Section G, Page 32 for inlet port plugs



Schematic shown with main R/V



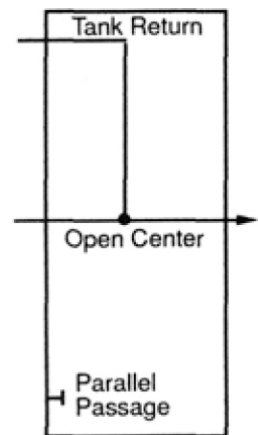
Note: For inlets with solenoid section pilot supply machining, see DVG35 inlet section E1

# Outlets

## Tank Return Type

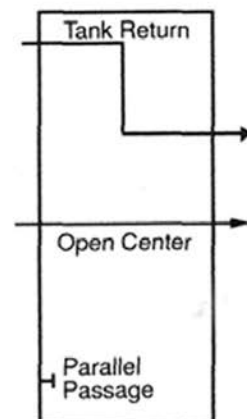
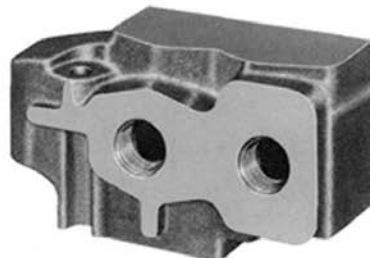
Code	End Port	Top Port
DVA35-TR55	1 1/4" NPT	1 1/4" NPT
DVA35-TR99	SAE-20	SAE-20
DVA35-TR00	NON-PORTED HOUSING	

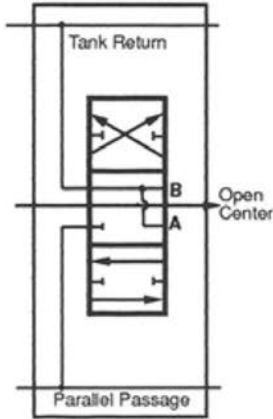
NOTE: See Section G, Page 32 for Port Plugs



## Pressure Beyond Type

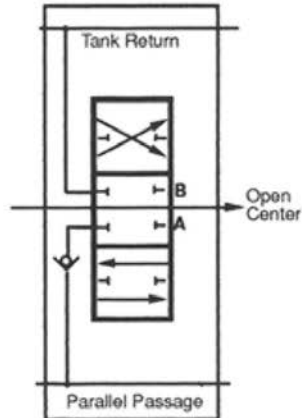
	End Port LP	End Port HP	Top Port LP	Top Port HP
DVA35-PB55	1 1/4" NPT	1 1/4" NPT	1 1/4" NPT	1 1/4" NPT
DVA35-PB90	SAE-20	SAE-20		
DVA35-PB09			SAE-20	SAE-20
DVA35-PB00	NON-PORTED HOUSING			





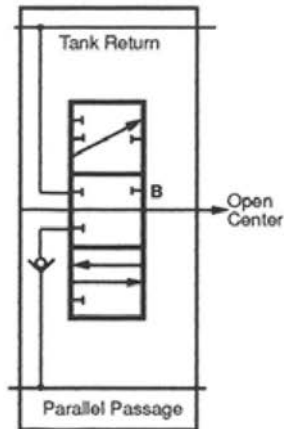
### MA8

Double-Acting Section  
4-Way, 3-Position, Float in Neutral  
Motor Spool



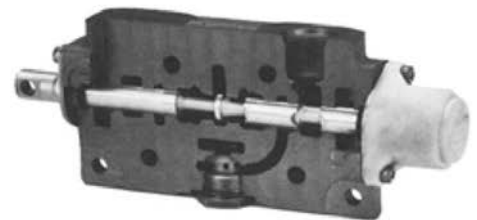
### DA8

Double-Acting Section  
4-Way, 3-Position, Hold in Neutral  
Cylinder Spool



### SA8

Single-Acting Section  
3-Way, 3-Position, Hold in Neutral  
Cylinder Spool



## Adjustable Relief Valve Cartridges For Inlets and Mid-section Inlets



Code	Description
DVA35-MRV-1	Main R/V pressure range 800-2000 psi. Factory set @ 1500 psi @ 50 gpm
DVA35-MRV-2	Main R/V pressure range 2001-2500 psi. Factory set @2500 psi @ 50 gpm.
DVA35-MRVP	Main relief valve plug

# Brief Circuit Descriptions

## Series Circuit

Available in DVA20 sections only.

If a machine's work cycle requires simultaneous as well as separate operation of individual hydraulic work functions, a series circuit is right for the job.

As with the other circuits, the oil flows through the open center when all spools are in neutral. There is no parallel passage in standard series sections because they feed directly from the open center passage. If more than one spool is operated, pump flow goes first to the section closest to the inlet. Return flow from the first section is fed back into the open center for use by downstream sections.

Downstream sections can be series, parallel or tandem and will operate in series with the upstream section.

In series circuits, operating pressure is cumulative. Therefore, the sum of the pressures in the circuits can not exceed the circuit or main relief valve setting.

## Parallel Circuits

Parallel circuits are the most common on mobile equipment because more than one function can be operated simultaneously and at random. If two or more functions are fully operated at the same time, the one with the lightest load will assert priority because the fluid will take the path of least resistance. However, the operator can divide the flow between functions by metering the spools.

Movement of the spool meters or shuts off the flow of oil thru the open center passage and pressurizes the parallel passage. Oil is then available, at the operator's discretion, to all work ports connected to the parallel passage.

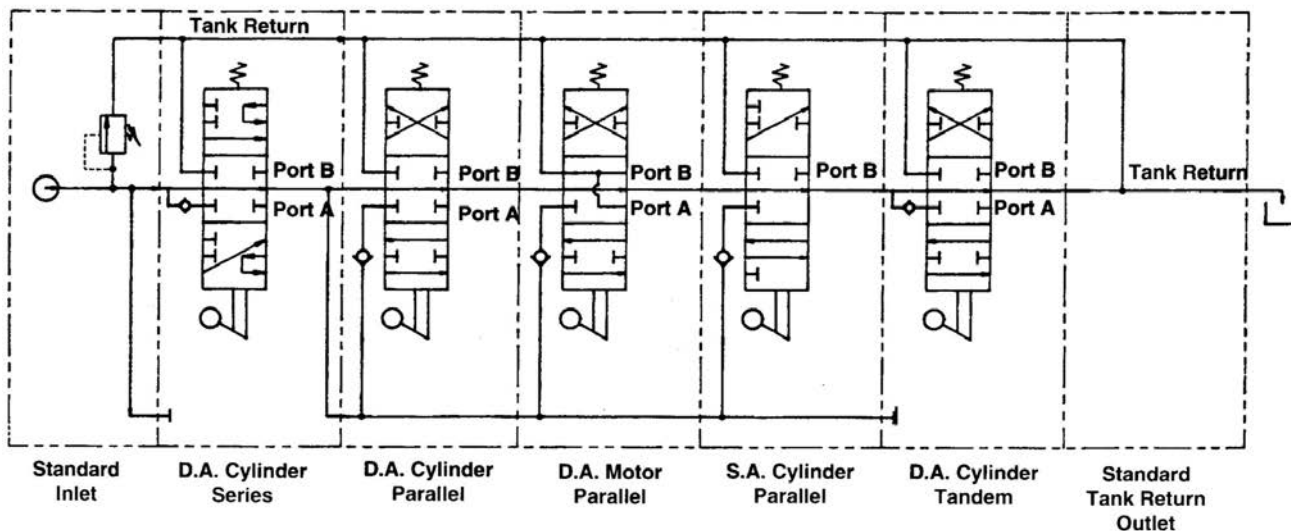
## Tandem Circuits

(Not available in the program)

Tandem circuits are sometimes called priority or standard circuits by other manufacturers. Tandem sections feed from the open center passage like series sections but the return flow is directed to the tank return passage and is not available downstream.

If a tandem section is followed by a series or tandem section, operating the tandem section nearest the inlet will assert priority and downstream sections will not function.

# Typical Work Section Schematics





# VA™/VG™ Valve Service Instructions

## INTRODUCTION

This manual has been prepared to assist you in the proper maintenance of the VA20™/VA35™ and VG20™/VG35™/VG80™ directional control valves. Before any work is done, we suggest that you read the assembly and disassembly instructions completely.

The first rule of good maintenance is cleanliness, which includes a clean environment. **MAKE SURE YOU DISASSEMBLE AND ASSEMBLE YOUR HYDRAULIC EQUIPMENT IN A CLEAN AREA.** Dirt is the natural enemy of any hydraulic system.

## GENERAL INFORMATION

The VA and VG model valves are updated versions of our proven A20™ and A35™ units. The VG models are cast from compacted graphite, a high strength iron alloy, which allows the valve to be rated to 3500 psi. VA models are cast from gray iron and are rated at 2500 psi. These open-center, directional-control valves are available in parallel, tandem, and series circuitry. As needed, the sectional, stack-type construction provides flexibility for the addition or subtraction of work sections to an existing valve bank. This design also permits the combination of parallel, tandem, and series circuitry in a single bank. The internal coring of each valve section determines its circuitry and the number of gasket seals required.

All sections with optional features, such as port relief valves, crossover relief valves, and anti-cavitation checks, are dimensionally larger when measured from the top of the port to the bottom of the housing. These are referred to as “hi-boy” sections. Those without work-port options can use the low-profile castings, which are called “lo-boy” sections.

## REPLACEMENT PARTS

The illustrations and instructions in this manual apply only to the VA/VG series assemblies, subassemblies, and components. All valve components, except for spools and housings, are available as replacement parts or subassemblies. Spools are hone-fitted to their individual housings, so damage to either of these components means the entire section must be replaced.

We recommend that you use only genuine VA/VG series replacement parts in your service program. Manufactured to the same exacting tolerances and quality controls as the original equipment, genuine VA/VG replacement parts may help prevent premature, component failure and costly downtime. Service parts and assemblies are available through your original equipment dealer or any authorized distributor.

## MAINTENANCE

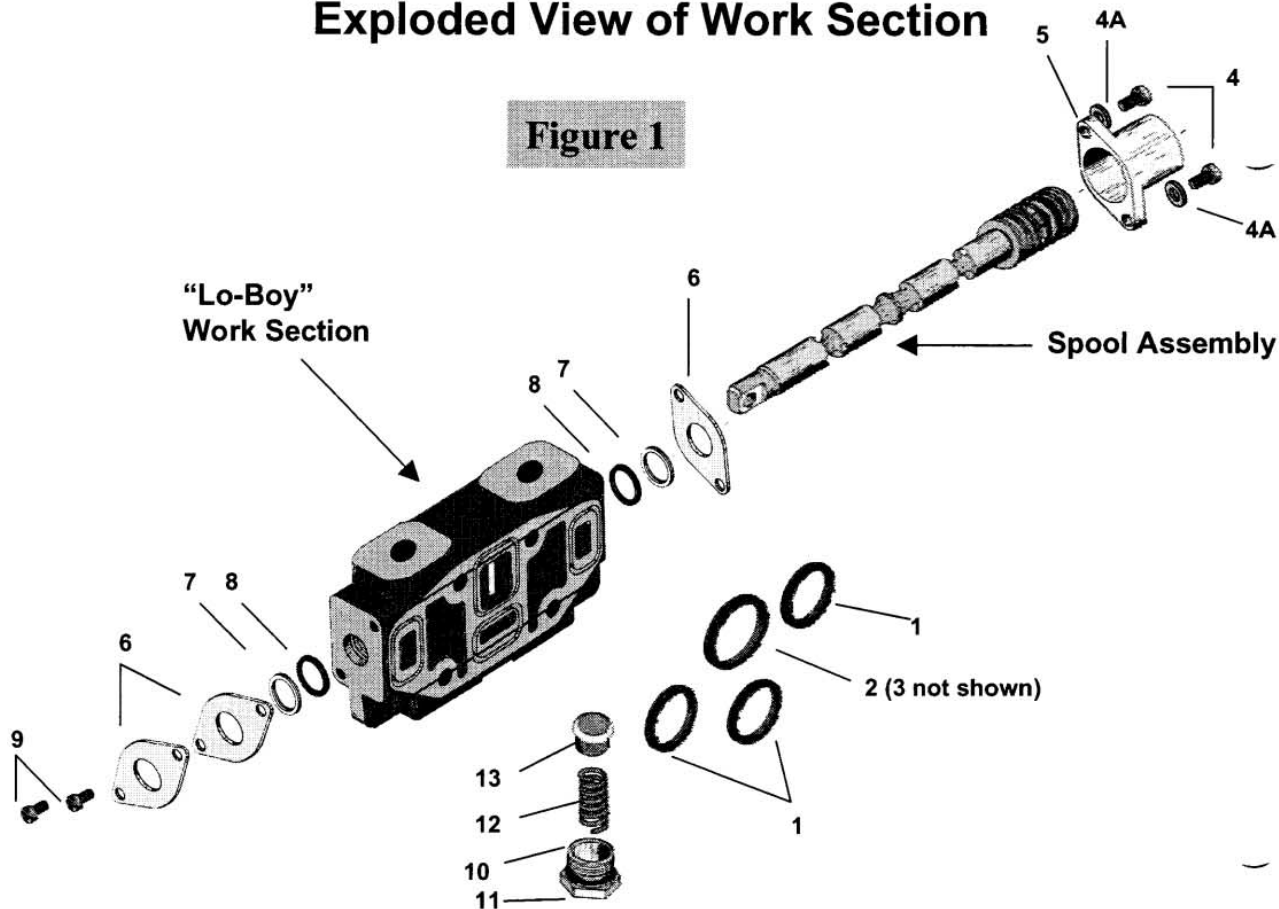
Valves are often used in hazardous environments. Inspect them frequently for damage due to improper use, corrosion or normal wear. If needed, repairs should be made immediately.

**Always refer to the machine manual for the proper procedure to remove the valve from the machine.**

Remove the valve bank from the equipment, disconnecting all hoses, fittings, control handles and linkage connectors that might be attached to the valve. Plug all ports and thoroughly clean the exterior of the valve bank, then the port plugs can be removed.

### Exploded View of Work Section

Figure 1



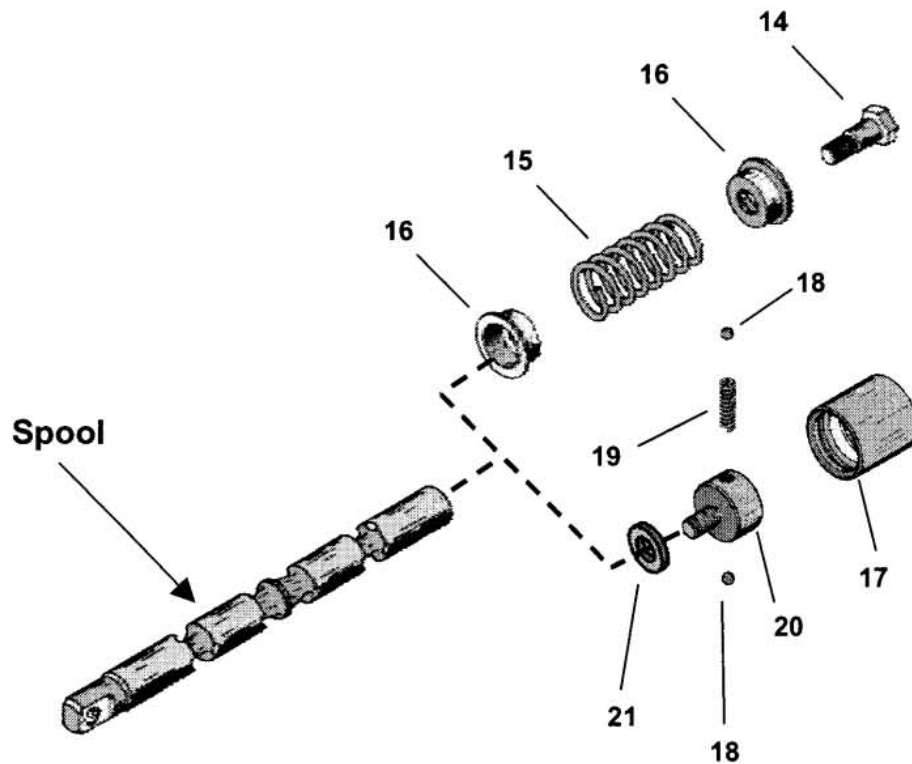
#### Parts List For Work Section

Item	Description	Qty.	VA/VG20 Part No.	VA/VG35 Part No.	VG80 Part No.
<b>Parallel Section Seals* See Figure 1</b>					
1.	Square Seals	3	391-2881-206	391-2881-200	391-2881-433
2.	Square Seal	1	391-2881-200	391-2881-403	391-2881-670
<b>Series Section Seals</b>					
1.	Square Seals	2	391-2881-206	391-2881-200	.....
3.	Square Seal	1	391-2881-627	391-2881-628	.....
<b>Parallel and Series Section Component Parts. See Figure 1</b>					
4.	Back Cap Screws	2	391-1433-020	391-1433-009	(4) 391-1402-068
4A.	Lock washers	8	.....	.....	391-3783-039
5.	Back Cap	1	341-6000-100	342-6000-100	341-0585-099
6.	Retainer Plates	3	391-2183-001	391-2183-005	391-2183-157
7.	Back up Rings	2	391-2681-378	391-2681-426	391-2681-285
8.	Spool Seals	2	391-1985-014	391-2887-212	391-2881-096
9.	Retainer Plate Screws	2	391-1433-015	391-1433-002	(4) 391-1402-015
10.	Check Valve Cap Or Valve Cap (F.I.N.)	1	391-0581-044 391-2281-015	391-0581-044 391-2281-015	391-0585-099 .....
11.	O Ring Seal **	1	391-2881-204	391-2881-204	391-2881-249
12.	Check Spring **	1	391-3581-713	391-3581-713	391-3581-778
13.	Check Valve Poppet **	1	391-2481-069	391-2481-069	391-2383-091

\*Parallel Sealing Face includes inlets and mid-inlets.

\*\*Not required in Float-in-neutral Sections.

**Figure 2**



**Spring Centered and Detent Spool Operators. See Figure 2**

14.Stripper Bolt	1	391-1432-022	391-1432-021	391-1402-452
15.Centering Spring	1	391-3581-608	391-3581-633	391-3581-330
16.Spring Guides	2	391-1642-045	391-1642-013	391-1642-161
17.Detent Sleeve	1	391-3283-015	391-3283-008	391-3384-310
18.Detent Balls	2	391-0282-010	391-0282-009	391-0282-011
19.Detent Spring	1	391-3581-130	391-3581-015	391-3581-316
20.Detent Poppet Retainer	1	391-2583-008	391-2583-006	391-3384-311
21.Detent Spacer	1	.....	.....	391-3782-208



## 4

## Valve Disassembly Instructions

Reference exploded view and parts list on page 2 and 3 for work section detail.

### Step 1 - Valve Bank

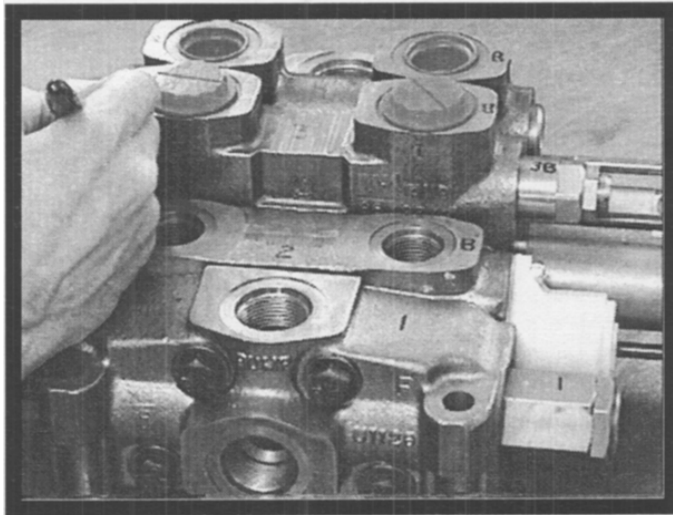
This step is the most critical in the disassembly procedure. It should be followed closely to ensure that the valve bank is properly reassembled after repairs have been made.

With a waterproof, quick-drying marker, mark each casting with a sequential number. Start by marking the inlet casting with the #1 and finish by marking the outlet with the highest number.

Next, mark the port boss closest to the back cap on each work section with a "B" (for back cap end).

Then, mark the port boss closest to the spool clevis on each work section with a "C" (for clevis end).

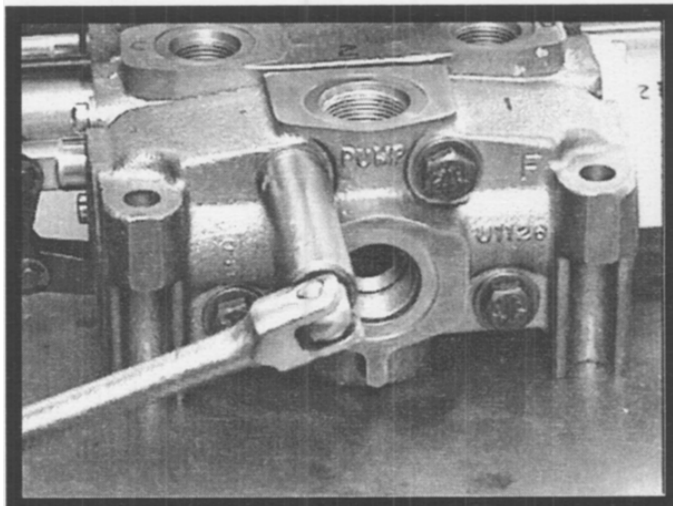
Finally, if relief valves are removed from the valve bank they must be marked with the corresponding number of the casting and port location (B or C) from which they were removed. Inlet and mid-inlet relief valves are marked with a casting number only.



### Step 2 - Tie Bolts

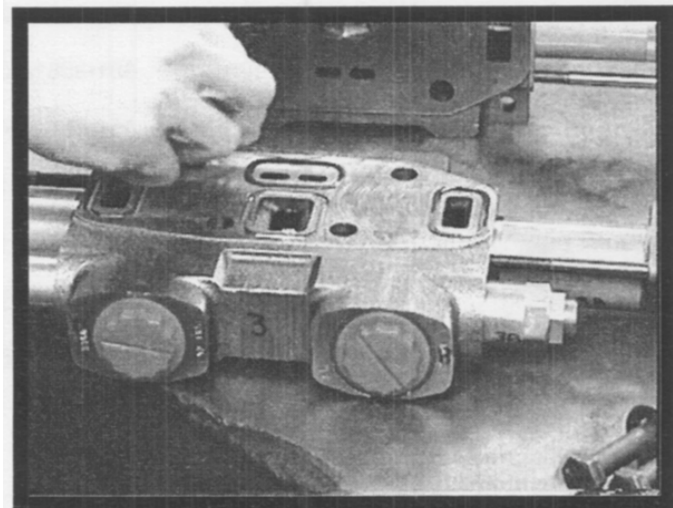
Remove the four, tie bolts that hold the bank together and separate the sections.

**NOTE: VA valve tie bolts thread into the outlet casting. VG valve tie bolts pass through the entire bank, requiring washers and hex nuts to be fastened at both ends of the bolt.**



### Step 3 - Section Seals

The inlet, mid-inlet and each parallel work section have four, section seals, (Fig. 1, items 1 & 2) on the downstream, mating face. Series work sections and the VA/VG35 split flow mid inlets have three section seals on the downstream mating face, (Fig. 1, items 1 & 3.) These section seals should be removed and discarded.

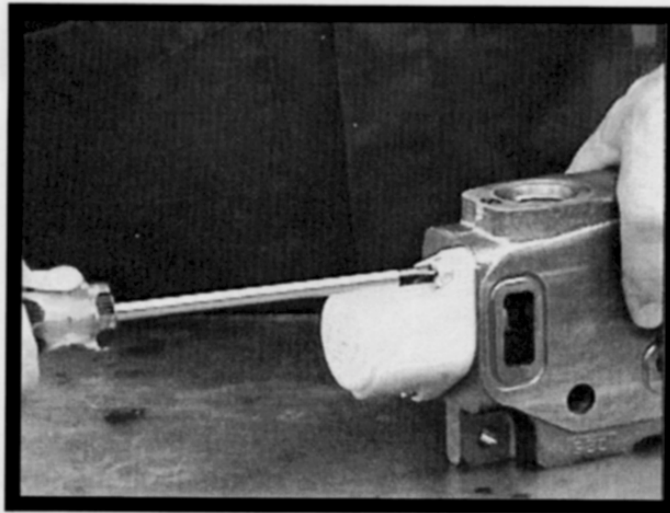


**REMINDER: ALL WORK MUST BE PERFORMED IN A CLEAN AREA.**



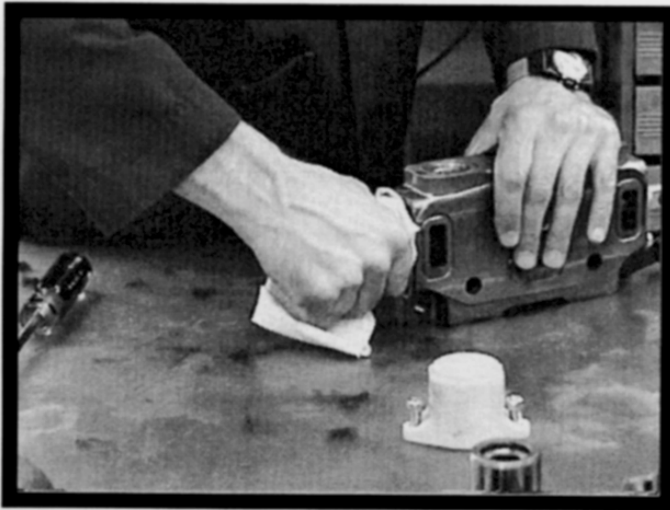
## Valve Disassembly Instructions

5



### Step 4 - Valve Back Cap

Using a large, Phillips-head screwdriver, remove the two, cap screws (Fig. 1, item 4) which fasten the back cap to the work section. Lightly tap the end of the screwdriver handle with a hammer to break adhesive. Remove the back cap (Fig. 1, item 5).

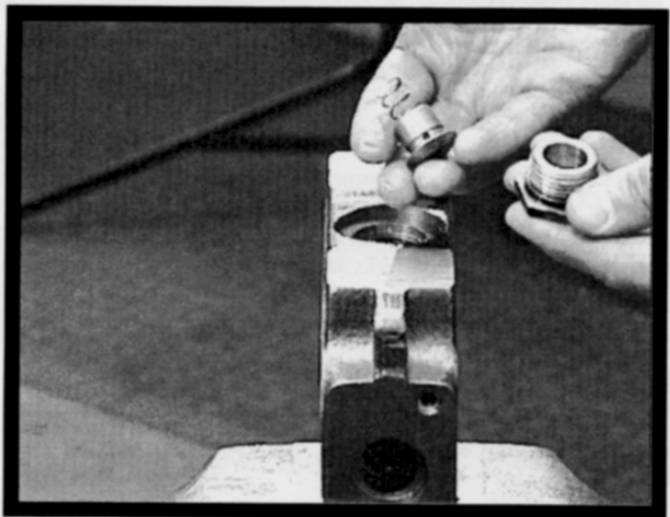


### Step 5 - Control Spool and Seals

Grasp the spring end of the spool with a clean, lint-free cloth and pull the spool out of the housing using a twisting motion. Generally, the rear, retainer plate (Fig. 1, item 6) back-up ring (Fig. 1, item 7) and spool seal (Fig. 1, item 8) will come out with the spool.

**CAUTION: For detented spool models, be careful not to remove the detent poppet sleeve (Fig. 2, item 17) unless it is to be serviced.**

Using a large, Phillips-head screwdriver, remove the two, retainer-plate screws (Fig. 1, item 9) from the spool clevis end of the work section. Lightly tap the end of the screwdriver handle with a hammer to break the adhesive. Remove the two, retainer plates (Fig. 1, item 6) the back-up ring (Fig. 1, item 7) and the spool seal (Fig. 1, item 8). Tag or mark with the appropriate, work section identification number. (See Step 1.) Spool seals (Fig. 1, item 8) and back-up rings (Fig. 1, item 7) should be discarded.



### Step 6 - Transition Check

The transition check is located in the bottom center of the work section housing. Carefully clamp the work section in a vise with ports down. Do not clamp on the machined surface. Remove the check-valve cap (Fig. 1, item 10) and its O-ring seal (Fig. 1, item 11). Discard the seal. Remove the check spring (Fig. 1, item 12,) and the check-valve poppet (Fig. 1, item 13).

**NOTE: Only cylinder work sections (ports blocked in neutral) have a transition check. Motor sections have only a cap plug.**

## 6

## Valve Disassembly Instructions

### Spool Disassembly

#### Spring Centered Spool

The spring assembly should not be removed from the spool unless these parts need to be replaced. Once the spool is free of the work section housing, it must be handled carefully to avoid damage. Place the spool vertically in a soft-jawed vise, clamping on the flat, spool clevis, and remove the stripper bolt (Fig. 1, item 14) with a wrench.

Lightly tap the stripper bolt with a hammer and a punch to help break the adhesive. Cautious application of heat may be required to free the stripper bolt, since an anaerobic thread adhesive was used during its assembly.

**CAUTION: Too much heat may distort the spool.**

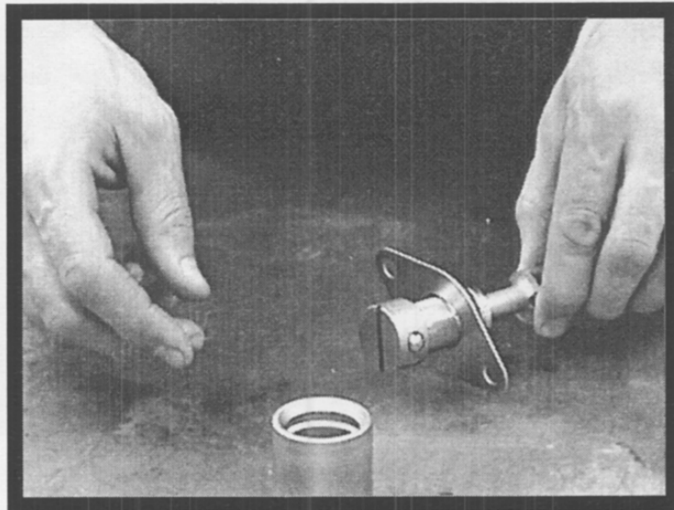
As the stripper-bolt threads disengage, the spring (Fig. 2, item 15) and spring guides (Fig. 2, item 16) will release abruptly from the spool.



#### Detent Spool

The detent assembly should not be removed from the spool unless these parts need to be replaced. Wrap the detent sleeve (Fig. 2, item 17) with a clean, lint-free cloth. Grip the cloth-covered sleeve and pull firmly. As the sleeve moves backwards, the detent balls (Fig. 2, item 18) and the detent spring (Fig. 2, item 19) will release abruptly. The cloth should capture these parts and prevent their loss.

Next, clamp the spool in a soft-jawed vise and remove the detent poppet retainer (Fig. 2, item 20). Place an undersized bar through the detent ball bore to serve as a wrench. Lightly tap the detent poppet retainer with a hammer and a punch to help break the adhesive. Cautious application of heat may be required again, since an anaerobic adhesive was also used in the detent retainer assembly.



**CAUTION: Too much heat may distort the spool!**

### CLEANING, INSPECTION, AND REPAIR

1. Inspect the spool bore, transition check seat and spool from each section for deep scratches, gouges or excessive wear. If any of these conditions exist, replace the section. Minor, surface damage on the control spool and check poppet can be carefully polished away with a very fine, crocus cloth.
2. Examine the machined surfaces of the valve housing for nicks and burrs that could cause leakage between sections. Lightly stone these surfaces to remove any rough spots.
3. Wash all parts thoroughly in a cleaning solvent and blow dry before beginning reassembly. Pay special attention to the number and letters marked on the parts in Step 1. If any marks are removed during cleaning, remark immediately.
4. Clean adhesive from threads of spool, stripper bolt, housing, cap screws and hex nut with Loctite™ Chisel Gasket Remover.

**CAUTION: A shallow-milled relief area extends across the O-ring face of the valve housing. This should not be stoned or ground off!**



## Valve Assembly Instructions

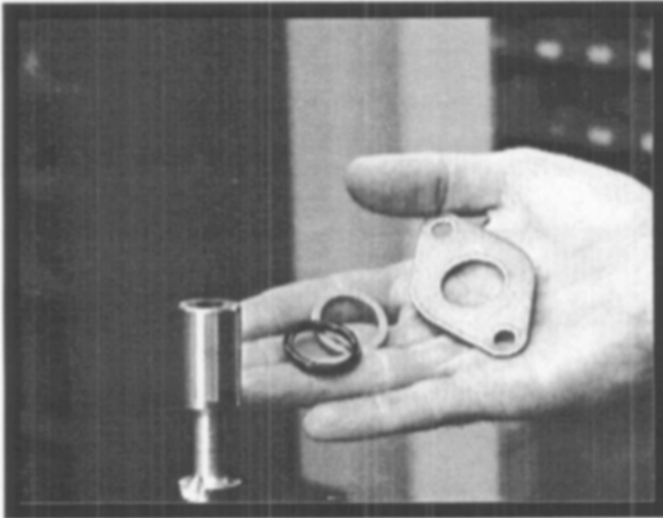
7

### Preparation of Parts

Spray the threads of the new stripper bolt (Fig. 2, item 14) tapped-threaded spool end, all screws and screw holes on both ends of the housing with LOCQUIC Primer Grade NF™ and let dry.

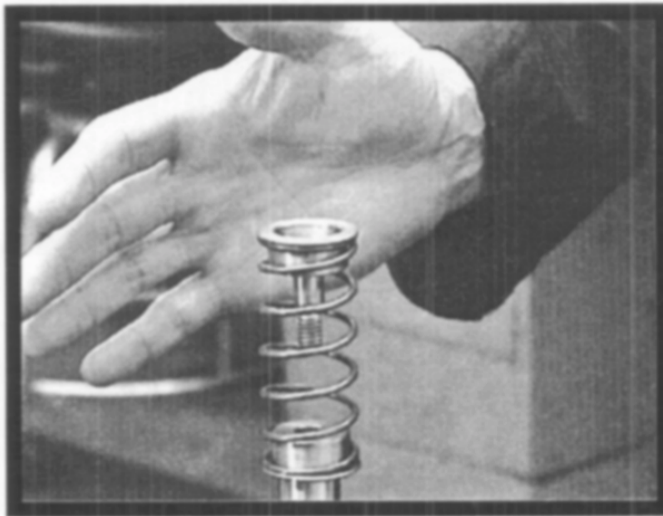
**CAUTION: Failure to follow the recommended assembly instructions can result in poor performance or product malfunction. Product should be thoroughly tested to ensure proper operation before the valve is placed back into service.**

### Spring Center Spool Assembly



#### Step 1 - Spool Assembly-Spring Centered

Clamp the flat, clevis end of the control spool in a soft jawed vise. Apply Parker Super-O-Lube™ to the spool seal (Fig. 1, item 8 ) and slide it onto the end of the spool away from the clevis. Slide on the back-up ring (Fig. 1, item 7) and retainer plate (Fig. 1, item 6). Position these items onto the spool, so that they do not interfere with the spool operator mechanism during assembly. Do not allow the O-ring to come in contact with the sharp edge of the spool notches.



#### Step 2 - Attach Spring Guides and Spring

Apply 2 - 3 drops of Loctite 262™ or equivalent anaerobic adhesive near the middle of the female threads in the spool. Assemble the spring guides (Fig. 2, item 16) centering spring (Fig. 2, item 15 ) and stripper bolt (Fig.2, item 14, ) onto the spool (Reverse of Step 7). Torque the stripper bolt to 175 in. lbs. +/-4 in. lbs.

**CAUTION: Care must be taken to ensure that the spring retainer is not pinched under the shoulder bolt during assembly. This can result in burrs that may cause spool binding. Check for binding by compressing the spring and guides or by rotating the spring guide nearest the housing.**

**CAUTION: Follow the adhesive manufacturer's instructions for proper cleaning and curing. Failure to clean and prepare parts properly may result in assembly failure!**

Lightly coat the centering spring with high- temperature grease to prevent rusting. Set the spool assembly aside and let it cure for a minimum of 1 hour. After curing, test the stripper bolt to make certain it can withstand 125 in. lbs. of breakaway torque.

8

## Valve Assembly Instructions

### Detent Spool Assembly

#### Step 1 - Spool Assembly-Detent

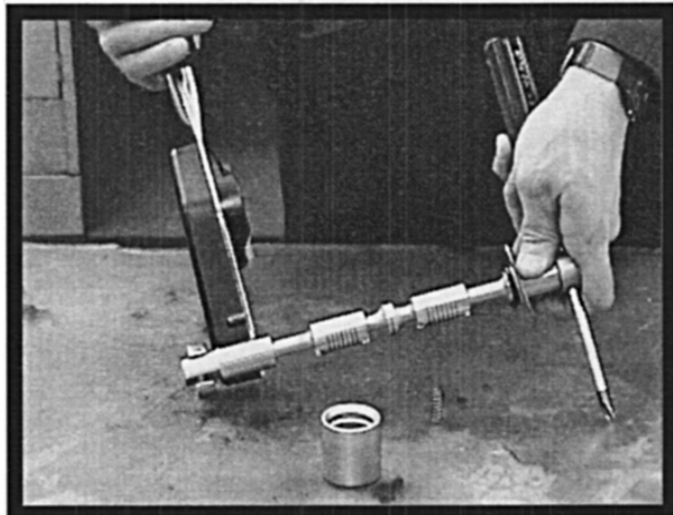
Apply Parker Super-O-Lube™ to the spool seal (Fig. 1, item 8) and slide it onto the spool. Slide the back-up ring (Fig. 1, item 7) and one, retainer plate (Fig. 1 item 6) onto the spool. Position these items onto the spool, so that they do not interfere with the spool operator mechanism during assembly. Do not allow the O-ring to come in contact with the sharp edge of the spool notches. Apply 2 - 3 drops of Loctite 262™ or an equivalent, anaerobic adhesive near the middle of the female threads in the spool.

**CAUTION: Follow the adhesive manufacturer's instructions for proper cleaning and curing. Failure to clean and prepare parts properly may result in assembly failure.**



#### Step 2 - Spool Assembly-Detent

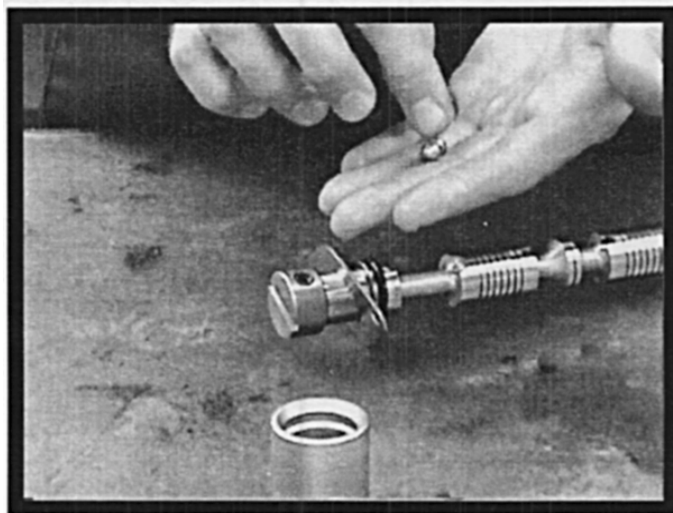
Thread the detent ball retainer (Fig. 2, item 20) into the spool end. Torque the detent ball retainer to 175 in. lbs. +/- 4 in. lbs.. This can be accomplished by using a crows-foot socket on the flats of the clevis, and holding the spool by inserting a round, steel rod or screwdriver through the hole in the ball retainer.



#### Step 3 - Detent Balls and Spring

Next, lightly coat the detent balls (Fig. 2, item 18) detent spring (Fig. 2, item 19) and entire inside diameter of the detent sleeve (Fig. 2, item 17) with high-temperature grease.

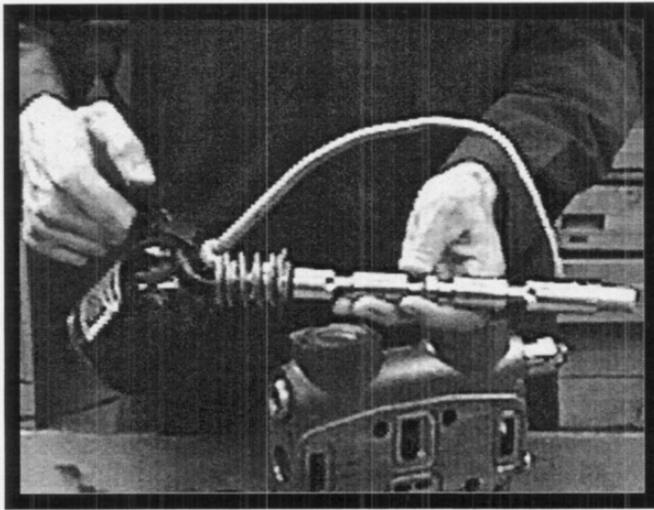
Insert the detent spring into the through hole in the detent ball retainer. Place the steel balls on the ends of the spring. Compress the balls and spring, then slip on the detent sleeve. (Note: The detent sleeve is not symmetrical; one end of the sleeve has a lead-in chamfer. This chamfer must face the spool clevis when assembled.) Move the detent sleeve to the neutral or middle position to prevent the subassembly from separating during subsequent steps.





## Valve Assembly Instructions

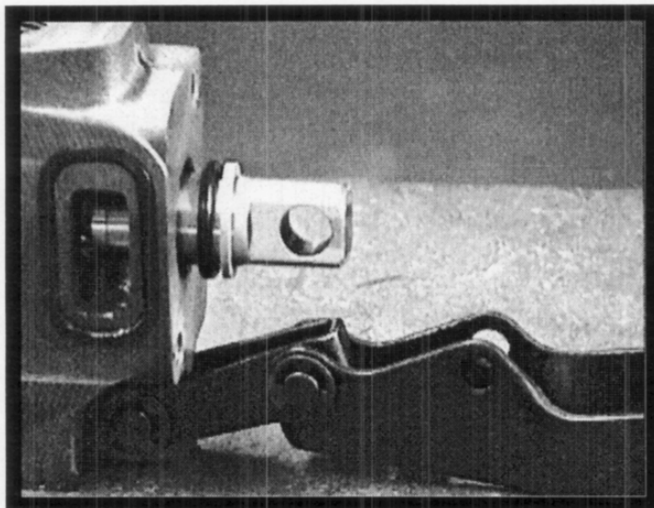
9



### Step 1 - Spool Subassembly

Apply 2 - 3 drops of Loctite 262™ or equivalent to the fillister screw holes on both ends of the housing.

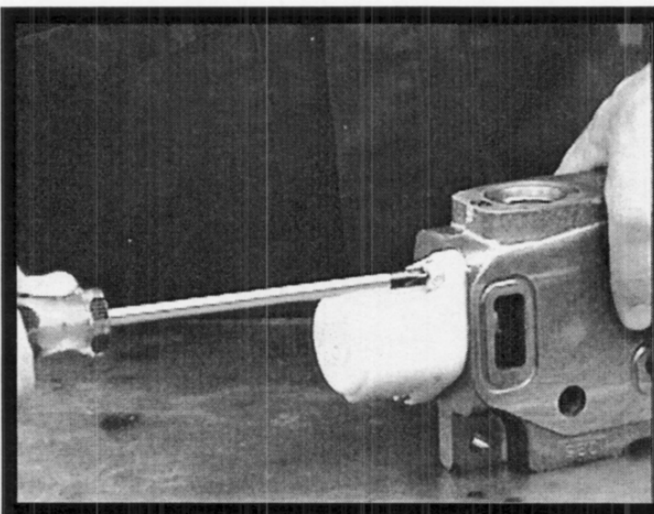
Apply a light coating of clean, hydraulic oil to the valve spool. Carefully insert the spool assembly into the housing. Use caution to avoid causing burrs. Be careful not to pinch, roll or damage the seals. Make sure that the spool and housing are in the proper orientation (see Step 1, page 6 disassembly).



### Step 2 - Spool Seal and Back up

Apply Parker Super-O-Lube™ to the spool seal (Fig. 1, item 8) and slide it onto the spool. Slide on the back-up ring (Fig. 1, item 7). Push both items into the counter-bore until they bottom out.

Assemble the two, front, retainer plates (Fig. 1, item 6) using the two short, fillister screws (Fig. 1, item 9). Check retainer plates for proper alignment. Tighten to a final torque of 34 in. lbs. +/- 2 in. lbs..



### Step 3 - Back cap

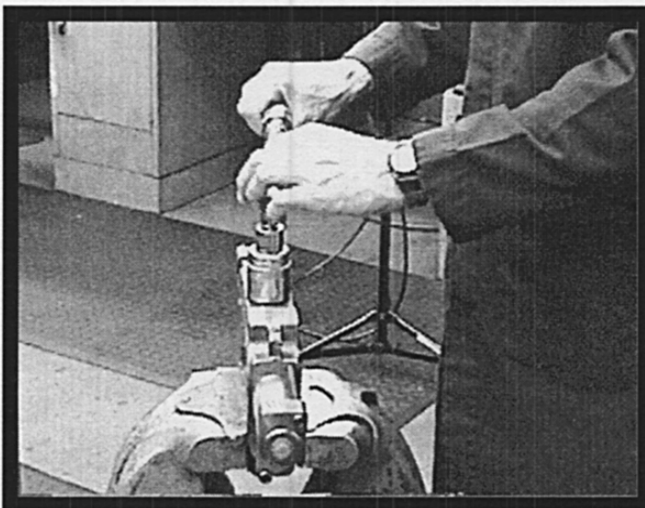
Install the back cap using the two, long, fillister screws (Fig. 1, item 4). Tighten to a final torque of 34 in. lbs. +/- 2 in. lbs.

**Caution: Excessive torque will damage the back cap ears!**

## Valve Assembly Instructions

### Step 4 - Install Transition Check

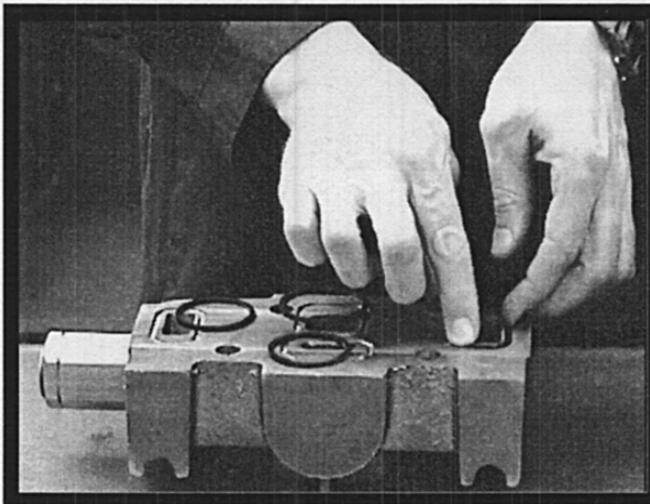
Inspect transition check components for cleanliness. Install check poppet (Fig. 1, item 13) into the transition check cavity. Align the check spring (Fig. 1, item 12) square to the poppet, then carefully place the check cap (Fig. 1, item 11) over the poppet and spring. Turning by hand, engage several threads. Tighten to a final torque of 75 ft. lbs. +/-4ft. lbs..



### Step 5 - Relief Valves

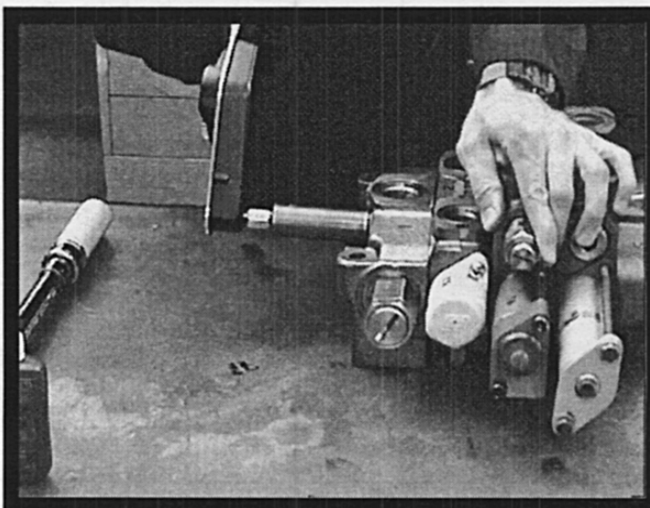
Return all relief valves to their proper positions and torque to 75 ft. lbs.

Install new, section seals. Place section seals (Fig. 1, items 1 & 2, or items 1 & 3) in the proper grooves. Make certain seals stay in their grooves during assembly.



### Step 6 - Install Tie Bolts

Slide the tie bolts through the inlet casting. If cap screws are used, place a washer on the cap screw prior to installation. Place the valve sections on the tie bolts in their proper sequence (see Step 1, page 4). Turning by hand, engage several threads in the outlet. If it is a VG series assembly, assemble nut and washer to either end of the stud and follow above instructions. Torque the tie bolts in a cross-corner pattern.



#### Tie Bolt Torque Values

VA20 - 29 ft. lbs. (348 in. lbs.)

VG20 - 42 ft. lbs. (504 in. lbs.)

VA35 - 34 ft. lbs. (408 in. lbs.)

VG35 - 75 ft. lbs. (900 in. lbs.)

VG80 - 150 ft. lbs. (1800 in. lbs.)



28	<b>Troubleshooting</b>	
TROUBLE	PROBABLE CAUSE	REMEDY
Oil leaks between sections	Pinched, blown or missing section seal	Replace section seal
	Stud fasteners not correctly torqued	Replace section seals and re-torque
	Mounting plate not level	Loosen mounting bolts and shim as required
	Contamination/burrs on seal	Clean seal groove, replace section seal
Oil leaks at either end of spool	Over-pressurized tank core	Correct high, back-pressure condition
	Worn or damaged spool seals	Replace seals and seal retainers
Spring - centered spools do not return to neutral	Broken centering spring	Replace centering spring
	Misalignment of operating linkage	Check linkage for mechanical binding
	Foreign particles in system	Clean valve and system
Load will not hold	Cylinder leaking or worn	Check cylinder - repair
	Port relief valve not holding	Remove and clean or replace
	Spool or housing scored or worn excessively	Replace section
Load drops when spool moved from neutral	Dirt or foreign particles lodged between check-valve poppet and seat	Disassemble, clean & reassemble
	Scored or sticking check-valve poppet	Replace poppet
No motion, slow, or erratic system operation	Worn pump	Check flow & pressure
	Defective cylinder or motor	Repair or replace
	Low-reservoir oil level	Add oil to specifications
	Clogged suction strainer	Clean or replace
	Suction line restricted	Check lines
	Relief valve not properly set	Check pressure setting
	Relief valve poppet or seat scored & sticking open	Replace relief valve
	Valve spool not shifted to full stroke	Check spool linkage travel

**Pilot-to-open, spring biased closed, unbalanced poppet logic element**

Capacity:  
60 gpm (240 L/min.)

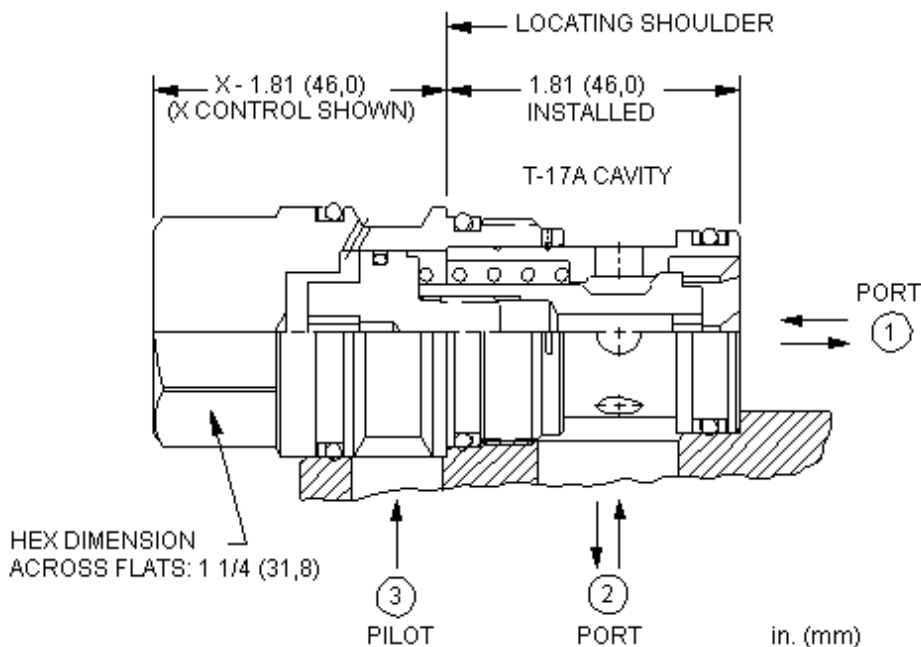
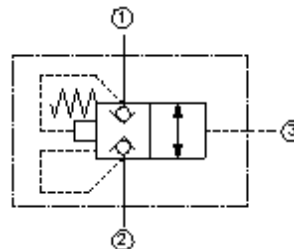
Functional Group:

Products : Cartridges : Corrosion Resistant : Logic Element : Unbalanced Poppet, Pilot-to-open, Switching Element, Spring biased closed, External Pilot Port 3 pilot source

Model:  
**LKHC**

**Product Description**

These unbalanced poppet, logic valves are 2-way switching elements that are spring-biased closed. Pressure at either work port 1 or 2 will further bias the valve to the closed position while pressure at port 3 will tend to open it. The force generated at port 3 must be greater than the sum of the forces acting at port 1 and port 2 plus the spring force for the valve to open. NOTE: The pilot area (port 3) is 1.8 times the area at port 1 and 2.25 times the area at port 2.



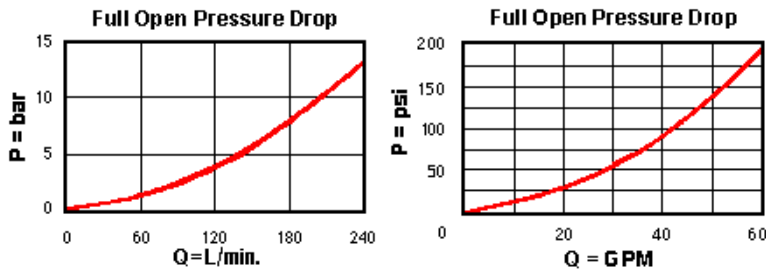
**Technical Features**

- Because these valves are unbalanced, operation is pressure dependent. Opening and closing of the poppet are functions of the force balances on three areas: 1) Port 1 = 100%, Port 2 = 80%, and Port 3 = 180%.
- These valves are pressure responsive at all three ports, therefore it is essential to consider all aspects of system operation through a complete cycle. Pressure changes at any one port may cause a valve to switch from a closed to an open position, or vice versa. All possible pressure changes in the complete circuit must be considered to assure a safe, functional system design.

- These valves have positive seals between port 3 and port 2.
- Incorporates the Sun floating style construction to eliminate the effects of internal parts binding due to excessive installation torque and/or cavity/cartridge machining variations.
- Stainless steel cartridge options P or W are intended for use within corrosive environments with all external components manufactured in stainless steel or titanium. Internal working components remain the same as the standard valves.

Technical Data

	U.S. Units	Metric Units
Cavity	T-17A	
Capacity	60	240 L/min.
Area Ratio, A3 to A1	1.8:1	
Area Ratio, A3 to A2	2.25:1	
Maximum Operating Pressure	5000	350 bar
Maximum Valve Leakage at 110 SUS (24 cSt)	10	10 drops/min. @70 bar
Pilot Volume Displacement	.15	2,5 cc
Series (from Cavity)	3	
U.S. Patent #	4,795,129	
Valve Hex Size	1 1/4	31,8 mm
Valve Installation Torque	150 - 160	200 - 215 Nm
Seal Kits	Buna: 990-017-007	
Seal Kits	Viton: 990-017-006	



Option Selection

LKHC-X D N



Preferred Options

External

**Direct-acting, pressure reducing valve**

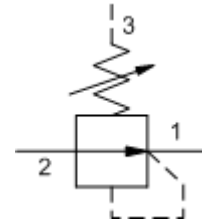
Capacity:  
80 gpm (320 L/min.)

Functional Group:  
**Products : Cartridges : Reducing : 3 Port : Direct Acting Reducer**

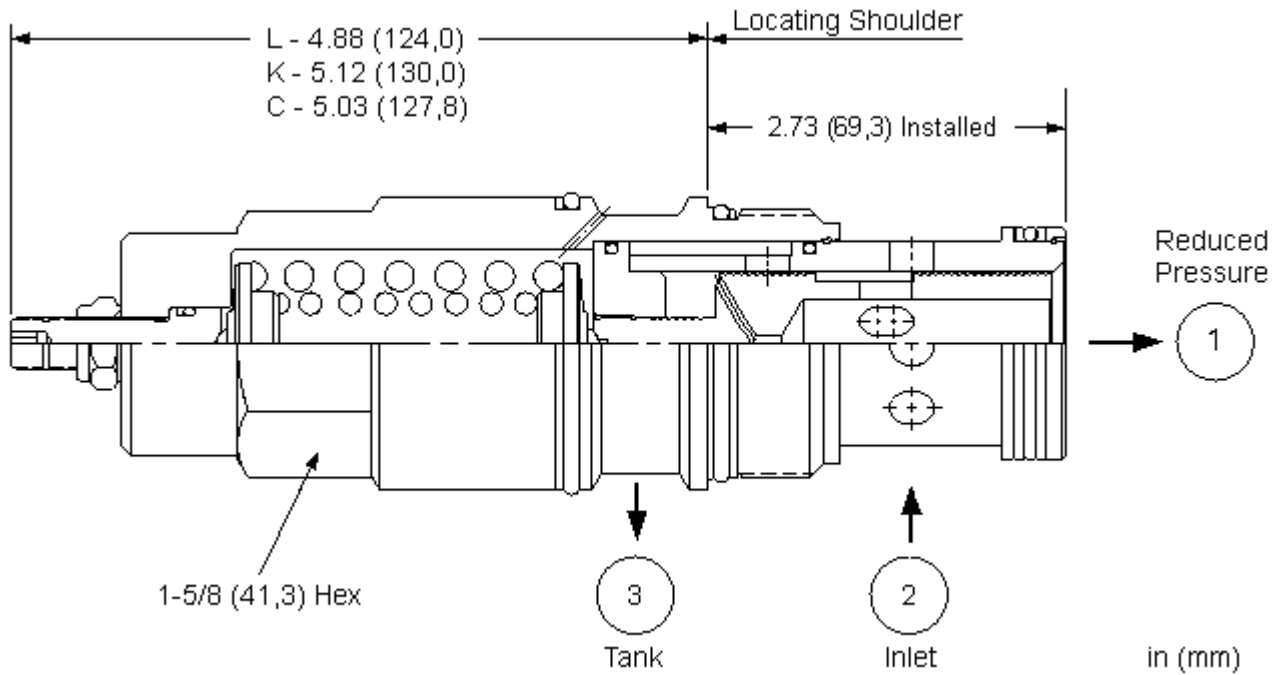
Model:  
**PRJR-LAN**

**Product Description**

Direct-acting, pressure reducing valves reduce a high primary pressure at the inlet (port 2) to a constant reduced pressure at port 1. These valves incorporate a damped construction for stable operation allowing the use of high reduced pressure.



[Download](#)



**Technical Features**

- Note: This valve has no relieving capability. It should not be used in a dead-headed application. If the reduced pressure side of the circuit has very low leakage the pressure may rise significantly. The pressure rise will vary from valve to valve.
- This type of valve, PR\*R, is a good replacement for an LP\*C as a normally open, restrictive compensating element if a higher pressure drop across an orifice is needed.
- Direct operated version offers superior dynamic response compared to equivalent pilot operated models.
- Pressure at port 3 is directly additive to the valve setting at a 1:1 ratio and should not exceed 5000 psi (350 bar).

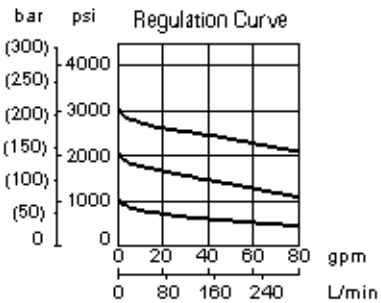
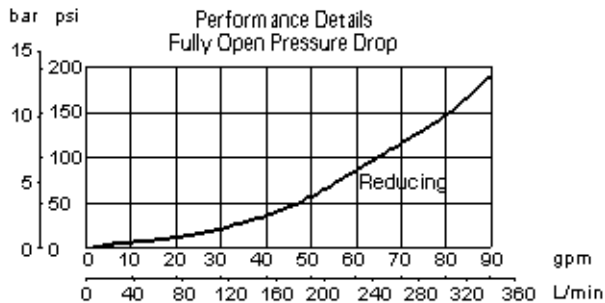
X Not Adjustable

N Buna-N  
V Viton

- Full reverse flow from reduced pressure (port 1) to inlet (port 2) may cause the main spool to close. If reverse free flow is required in the circuit, consider adding a separate check valve to the circuit.
- All spring ranges are tested for correct operation with 5000 psi (350 bar) inlet pressure.
- Suitable for accumulator circuits since the absence of pilot control flow results in reduced secondary circuit leakage.
- Leakage specified in Technical Data is out of port 3 with a supply pressure of 2000 psi (140 bar) and the valve set at mid range. This leakage is directly proportional to pressure differential and inversely proportional to viscosity expressed in centistokes.
- Incorporates the Sun floating style construction to minimize the possibility of internal parts binding due to excessive installation torque and/or cavity/cartridge machining variations.

**Technical Data**

	U.S. Units	Metric Units
Cavity		T-19A
Capacity	80 gpm	320 L/min.
Adjustment - Number of Clockwise Turns to Increase Setting		5
Factory Pressure Settings Established at	2 in <sup>3</sup> /min.	30 cc/min.
Maximum Operating Pressure	5000 psi	350 bar
Maximum Valve Leakage at 110 SUS (24 cSt)	5 in <sup>3</sup> /min.	80 cc/min.
Series (from Cavity)		Series 4
Valve Hex Size	1 5/8 in.	41,3 mm
Valve Installation Torque	350 - 375 lbf ft	465 - 500 Nm
Adjustment Screw Internal Hex Size	5/32 in.	4 mm
Adjustment Locknut Hex Size	9/16 in.	15 mm
Adjustment Nut Torque	108 lbf in.	12 Nm
Seal Kits - Cartridge		Buna: 990-019-007
Seal Kits - Cartridge		Viton: 990-019-006
Model Weight	3.50 lb.	1.59 kg.



**PRJR-LAN**

**Control**

**Adjustment Range**

**External Material/Seal Material**

L Standard Screw Adjustment

A 750 - 3000 psi (50 - 210 bar), 1000 psi (70 bar) +0.00

N Buna-N +0.00