

# KT20-50K

20" (508 mm) 50,000 lbs-ft Hydraulic Power Tong



**SPECIFICATIONS | OPERATION | MAINTENANCE | PARTS**





# ORIGINAL INSTRUCTIONS

THIS TECHNICAL DOCUMENT APPLIES TO THE FOLLOWING MODELS:		
TONG MODEL	REV	DESCRIPTION
80-1302-1	4	Tong is equipped with Rineer 125-82 motor, motor valve, lift cylinder valve, and chain sling.
80-1302-2	4	Tong is equipped with Staffa B080 motor, motor valve, lift cylinder valve, and chain sling.
80-1302-5	0	Tong is equipped with Staffa B080 motor, motor valve, lift cylinder valve, and chain sling. <b>CLOSED CENTRE SYSTEM</b>

**ALL MCCOY TONGS ARE EQUIPPED WITH A “SAFETY DOOR” ROTATION INTERLOCK SYSTEM**

McCoy has made an effort ensure that all illustrations are accurate, but please note that some illustrations used in this manual may not exactly visually match your equipment.

This manual applies to CE-marked versions of the equipment listed in the table of supported models.

**PATENTED & PATENTS PENDING**



**This page intentionally  
left blank**



# WARNING

## READ BEFORE USING EQUIPMENT

### AUTHORIZED USE ONLY

Only authorized personnel deemed competent to operate, maintain, and repair this equipment shall do so.

Do not operate equipment without fully reviewing and complying with all safety guidelines contained within this manual.

A "LOAD-BEARING DEVICE" IS A CHAIN SLING, RIGID SLING, SPREADER BAR ASSEMBLY, FRAME, OR ANY OTHER DEVICE THAT BEARS THE PARTIAL OR TOTAL WEIGHT OF THE EQUIPMENT FOR WHICH THIS MANUAL HAS BEEN PRODUCED

THE LOAD-BEARING DEVICE SUPPLIED BY MCCOY GLOBAL IS DESIGNED TO SUPPORT THE EQUIPMENT DESCRIBED IN THIS MANUAL. MCCOY GLOBAL WILL NOT GUARANTEE THE ABILITY OF THE LOAD-BEARING DEVICE TO SUPPORT ANY OTHER PART, ASSEMBLY OR COMBINATION OF PARTS AND ASSEMBLIES. MCCOY GLOBAL WILL NOT GUARANTEE THE ABILITY OF THE LOAD-BEARING DEVICE TO LIFT OR SUPPORT THE EQUIPMENT DESCRIBED IN THIS MANUAL IF THERE ARE ANY MODIFICATIONS TO THE LOAD-BEARING DEVICE, OR ANY ADDITIONS TO THE EQUIPMENT DESCRIBED IN THIS MANUAL THAT ADD WEIGHT TO THE EQUIPMENT, UNLESS SUPPLIED BY MCCOY GLOBAL.

WHEN RE-ASSEMBLING LOAD-BEARING DEVICES (CHAIN SLINGS, RIGID SLINGS, BACKUP LEGS, ETC.) NOTE THAT THE ASSOCIATED FASTENERS MUST BE TIGHTENED TO THE CORRECT TORQUE SPECIFIED FOR THAT SIZE OF FASTENER (SEE SECTION 3 - OVERHAUL). ANY THREADED FASTENER IN A LOAD-BEARING DEVICE MUST BE SECURED WITH RED OR BLUE LOCTITE™.

ANY REPLACEMENT FASTENER (BOLTS, NUTS, CAP SCREWS, MACHINE SCREWS, ETC.) USED DURING MAINTENANCE OR OVERHAUL MUST BE GRADE 8 OR EQUIVALENT UNLESS OTHERWISE SPECIFIED.



**This page intentionally  
left blank**

Copyright © 2007 - 2014 McCoy Global, including its wholly owned subsidiaries, (“McCoy”), all rights reserved. This document is the property of McCoy and is supplied as reference information for users of our products. This document and the contents within are considered confidential information, not to be disclosed, copied, transmitted, transcribed in any form, or stored on any type of data storage media without the express written consent of McCoy.

McCoy has made every effort to ensure the information contained in this document is accurate and current. This manual is intended to provide equipment operation and safety instructions for your equipment. However, McCoy does not warrant or guarantee that the information is either complete or accurate in every respect and the user of the manual should consult with its McCoy sales representative for any clarifications and updates.

The user of the manual shall protect, indemnify, and hold harmless McCoy and its directors, officers, employees, and agents from and against all liability for personal injury, death, or property damage resulting directly or indirectly from the use of the information contained in this manual.

Observance of all descriptions, information and instructions set out in this manual is the full responsibility of the user. This manual is intended for guidance and informational purposes and must be used in association with adequate training and on-the-job supervision to provide safe and effective equipment use.

It is the responsibility of the user to conform to all regulations and requirements issued by an authority or agency which may affect the operation, safety or equipment integrity, that may overrule the content of this documentation.

The user will acknowledge and obey any general legal or other mandatory regulation in force relating to accident prevention, safety, and equipment integrity.

<b>Summary Of Revisions</b>					
<b>Date</b>	<b>Section</b>	<b>Page</b>	<b>Description Of Revision</b>	<b>Approved</b>	
June 2007	N/A	N/A	Initial Release		
Oct 2007	Intro	iii	Added list of tong models covered by this manual		
		v	Added Warnings		
	4	4.9	Added torque table for load-bearing components		
Dec 2007	7	7.15	Corrected part numbers for items B, J, & L		
June 2011	All	All	Re-branded manual	SH	
	Intro	ix	Added Table of Illustrations		
	All	All	Improved warnings throughout manual		
	2				Moved “Assembly Instructions” to “Maintenance” section, Section 2 becomes “Setup & Operation”
		2.1			Added Section “Sling & Load Bearing Device Safety”.
		2.8			Replaced hydraulic schematic & hydraulic B.O.M.
		2.9			Added hydraulic component identification graphics
		2.13			Added Section “Tong Rig-up & Leveling”.
		2.17			Replaced “valve operation” graphics
		2.18			Added Subsection “Shifting Gears”.
		2.19			Added Section “ Making & Breaking Connections”.
	3				Renumbered Maintenance Section as Section 3
		3.1			Added Section “General Maintenance Safety Practices”.
		3.1			Added Section “Preventive Maintenance Practices”.
		3.2 - 3.6			Replaced lubrication point graphics
		3.8			Added Subsection “Door Alignment”.
		3.8			Added Subsection “Shifter Detent Force Adjustment”.
		3.12-3.21			Added Section “Assembly Procedures”.
		3.22			Added Section “Daily Power Tong Inspection & Maintenance”.
		3.24			Added Section “Monthly Power Tong Inspection & Maintenance”.
3.27			Added Section “Daily Power Unit Inspection & Maintenance”.		
3.28			Added Section “Tubular Connection Equipment De-commissioning”.		
3.31			Added Section “Tubular Connection Equipment Re-commissioning”.		
<b>Continued On Next Page</b>					

# KT20-50 HYDRAULIC POWER TONG

Summary Of Revisions (Continued)					
Date	Section	Page	Description Of Revision	Approved	
June 2011	4		Renumbered "Troubleshooting" section as Section 4	SH	
			Removed old section "Storage Recommendations" (see Maintenance section, Equipment de-commissioning & Equipment re-commissioning).		
	5				Renumbered "Assemblies & Parts" section as Section 5
		5.2 - 5.3			Replaced "Gear Train Layout" images with current versions.
		5.4 - 5.5			Updated Support Roller graphics & BOM to reflect current version
		5.6 - 5.7			Updated Door Pivot Roller graphics & BOM to reflect current version
		5.18-5.19			Removed Tong Body graphics & BOM, inserted Hydraulic Supports & Hanger Legs graphics and BOM.
		5.20-5.21			Removed existing graphics, inserted Motor Options graphics & BOM.
		5.22-5.23			Updated Brake Band graphics & BOM to reflect current version
5.28-5.29		Updated Door Assembly graphics & BOM to reflect current version			
6	All		Complete revision of torque measurement section		
Jan 2012	All	All	Updated manual to conform to current branding standards.	SH	
	1	1.3	Corrected specifications		
	2	2.12	Added jaw die kits to list of available kits		
	5	5.22	Inserted diagrams & BOM - torque gauge mounts		
AUG 2012	Intro	iii	Updated list of supported tong models	S. Panchal	
	1	1.2	Updated illustration of dimensions		
		1.3	Inserted illustration of additional hazard areas		
		1.4	Inserted illustration & identification of FARR CE Nameplate		
	2	2.1			Inserted new section "Initial Receipt & Inspection of Equipment"
		2.4			Renumbered section 2.C, "Sling & Load-Bearing Device Safety"
		2.7			Inserted new section 2.D, "Lift Cylinder Installation"
		2.10			Inserted revised schematic for non CE-Marked equipment (Open Centre)
		2.11			Inserted CE-applicable hydraulic schematic (Open Centre)
		2.12			Inserted schematic for non CE-Marked equipment (Closed Centre)
		2.13			Inserted CE-applicable hydraulic schematic (Closed Centre)
		2.16			Renumbered section "Hydraulic Connections" as subsection 2.E.3
		2.17			Revised "Tong Jaw Availability & Installation" and renumbered as section 2.F. Corrected table of standard jaw die kits.
		2.18			Renumbered "Tong Rig-up & Leveling" as section 2.G
		2.21			Renumbered "Tong Operation" as section 2.H.
		2.21			Inserted new subsection 2.H.2, "Operator Safety".
		2.22			Revised subsection 2.H.3, "Valve Operation"
		2.24			Inserted new subsection 2.H.5, "Pre-operational Checks"
	2.26		Revised section "Making & Breaking Connections" and renumbered as section 2.I.		
	3	3.2			Inserted new section 3.D, "Hydraulic System De-Pressurizing"
3.2			Renumbered "Lubrication Instructions" as section 3.E.		
3.7			Renumbered "Adjustments" section 3.F.		
3.10			Renumbered "Recommended Periodic Checks" as section 3.G.		

Continued on next page

**This technical manual represents the most current version of the equipment contained within. If older versions of this manual are required, please contact your sales representative.**

Summary Of Revisions (Continued)				
Date	Section	Page	Description Of Revision	Approved
AUG 2012	3	3.11-3.12	Revised "Overhaul Procedures - Disassembly" and renumbered as section 3.H. Corrected disassembly procedures and added CE-specific information and warnings.	S. Panchal
		3.13-3.22	Revised "Assembly Procedures" and renumbered as section 3.I. Corrected / revised assembly procedures and added CE-specific information and warnings.	
		3.23	Renumbered "Power Tong Daily Inspection & Maintenance" as section 3.J. Added CE-Specific information.	
		3.25	Renumbered "Power Tong Monthly Inspection & Maintenance" as section 3.K.	
		3.28	Revised "Tubular Connection Equipment De-Commissioning" and renumbered as section 3.L. Added packaging and shipping instructions, Retitled as "Tubular Connection Equipment De-Commissioning & Shipping".	
		3.38	Renumbered "Tubular Connection Equipment Re-Commissioning" as section 3.M.	
	4	4.1	Revised section 4.A, Troubleshooting - Tong Will Not Develop Sufficient Torque	
		4.2	Inserted new section 4.B, Troubleshooting - Relief Valve	
		4.4	Inserted new section 4.C, Troubleshooting - Safety Door	
		4.5	Renumbered "Troubleshooting - Tong Running Too Slowly" as section 4.D.	
		4.6	Renumbered "Troubleshooting - Failure of Jaws to Grip Pipe" as section 4.E.	
		4.7	Renumbered "Troubleshooting - Shifting" as section 4.F.	
	5	5.2	Inserted list of critical spare parts	
		5.3	Inserted list of recommended spare parts	
		5.4	Inserted list of parts needed for complete overhaul	
		5.20	Inserted new illustration & B.O.M, Cam Follower Array	
		5.24	Inserted new illustration & B.O.M, Shifter Assembly, CE Marked Tongs	
		5.26	Revised illustration & B.O.M., Hydraulic Supports & Hanger Legs	
	6	5.41	Added addition B.O.M. for CE-specific components, Safety Door Components.	
		6.1	Revised section 6.A, Basic Torque Measurement	
	Apr 2014	All	6.6	
5		All	Updated manual to newest branding standard & format	
		5.3	Updated part# for brake band adjustment spring, Recommended Spare Parts List	
		5.4	Updated part# for brake band adjustment spring, Parts Req'd For Overhaul	
		5.33	Updated part number in B.O.M. for #6, brake band adjustment spring	
	5.36-5.37	Updated & corrected B.O.M., hydraulic valve assembly		
5.41	Corrected B.O.M., Safety Door Components (CE-Marked)			

**This technical manual represents the most current version of the equipment contained within. If older versions of this manual are required, please contact your sales representative.**

**SECTION ONE: INTRODUCTION**

- Introduction & Contact Information ..... 1.3
- Equipment Specifications ..... 1.4

**SECTION TWO: SETUP & OPERATION**

- 2.A INITIAL RECEIPT AND INSPECTION OF EQUIPMENT..... 2.3
- 2.B MAJOR COMPONENT IDENTIFICATION ..... 2.3
- 2.C SLING / LOAD BEARING DEVICE SAFETY ..... 2.6
  - 2.C.1 Inspection Of Slings ..... 2.7
  - 2.C.2 Proper Use Of Load-Bearing Devices ..... 2.8
  - 2.C.3 Storage Of Load-Bearing Devices ..... 2.8
- 2.D LIFT CYLINDER INSTALLATION..... 2.9
  - 2.D.1 Installation Procedure ..... 2.9
  - 2.D.2 Lift Cylinder Connection ..... 2.10
  - 2.D.3 Lift Cylinder Safety ..... 2.10
- 2.E HYDRAULICS
  - 2.E.1 Hydraulic Schematics..... 2.12
  - 2.E.2 Hydraulic Component Identification ..... 2.16
  - 2.E.3 Hydraulic Connections ..... 2.17
- 2.F TONG JAW AVAILABILITY & INSTALLATION
  - 2.F.1 Jaw Availability ..... 2.19
  - 2.F.2 Jaw/Jaw Die Replacement..... 2.19
- 2.G TONG RIG-UP & LEVELING
  - 2.G.1 Suspension & Restraint ..... 2.20
  - 2.G.2 Tong Leveling ..... 2.22
- 2.H TONG OPERATION
  - 2.H.1 Operator Training ..... 2.23
  - 2.H.2 Operator Safety..... 2.23
  - 2.H.3 Valve Operation..... 2.23
  - 2.H.4 Shifting Gears ..... 2.25
  - 2.H.5 Pre-Operational Checks..... 2.26
  - 2.H.6 General Operational Comments ..... 2.27
- 2.I MAKING AND BREAKING CONNECTIONS ..... 2.28
  - 2.I.1 Making A Connection ..... 2.28
  - 2.I.2 Breaking A Connection..... 2.33
- 2.J EXTREME COLD WEATHER OPERATION PROCEDURES..... 2.35

**SECTION THREE: MAINTENANCE**

- 3.A GENERAL MAINTENANCE SAFETY PRACTICES ..... 3.3
- 3.B CLEANING ..... 3.3
- 3.C PREVENTIVE MAINTENANCE PRACTICES..... 3.3
- 3.D HYDRAULIC SYSTEM DE-PRESSURIZATION ..... 3.4
- 3.E LUBRICATION INSTRUCTIONS ..... 3.4
- 3.F ADJUSTMENTS
  - 3.F.1 Brake Band Adjustments:..... 3.9
  - 3.F.2 Door Latch Adjustment:..... 3.10
  - 3.F.3 Door Alignment..... 3.10
  - 3.F.4 Shifter Detent Force Adjustment: ..... 3.12
- 3.G RECOMMENDED PERIODIC INSPECTIONS ..... 3.12
- 3.H REMOVAL OF TOP PLATE FOR OVERHAUL ..... 3.13
- 3.I ASSEMBLY PROCEDURES..... 3.15
- 3.J DAILY INSPECTION & MAINTENANCE CHECKLIST ..... 3.25
- 3.K MONTHLY MAINTENANCE CHECKLIST - POWER TONG ..... 3.27
- 3.L TUBULAR CONNECTION EQUIPMENT DE-COMMISSIONING & SHIPPING PROCEDURE ..... 3.30
- 3.M TUBULAR CONNECTION EQUIPMENT RE-COMMISSIONING PROCEDURE ..... 3.34

**SECTION FOUR: TROUBLESHOOTING**

- 4.A TONG WILL NOT DEVELOP SUFFICIENT TORQUE ..... 4.3
- 4.B RELIEF VALVE IS INCORRECTLY SET OR NOT FUNCTIONING ..... 4.4
- 4.C SAFETY DOOR DOES NOT OPERATE OR IS MALFUNCTIONING ..... 4.6
- 4.D TONG RUNNING TOO SLOWLY..... 4.7
- 4.E FAILURE OF JAWS TO GRIP PIPE ..... 4.8
- 4.F FAILURE OR DIFFICULTY OF TONG TO SHIFT ..... 4.9
- 4.G GENERAL COMMENTS ..... 4.10

Continued on next page ...

**SECTION FIVE: PARTS AND ASSEMBLIES**

Critical Spare Parts List ..... 5.2

Recommended Spare Parts List ..... 5.3

Parts List - Complete Overhaul..... 5.4

Gear Train Layout ..... 5.6

Support Roller Assembly..... 5.8

Door Pivot Support Roller Assembly..... 5.10

Rotary Idler Assembly ..... 5.12

Pinion Idler Assembly..... 5.14

Pinion Assembly..... 5.16

Clutch Assembly..... 5.18

Cam Follower Array..... 5.20

Shifting Assembly ..... 5.22

Shifting Assembly - CE Marked ..... 5.24

Hydraulic Supports & Hanger Lugs..... 5.26

KT20-50K Tong Motor Options..... 5.28

KT20-50K Tong Torque Gauge Mounting Options ..... 5.30

Brake Band Assembly ..... 5.32

Cage Plate Assembly ..... 5.34

Hydraulic Assembly..... 5.36

Tong Door Assembly ..... 5.38

Safety Door Option..... 5.40

Rigid Sling Assembly..... 5.42

**SECTION SIX: TORQUE MEASUREMENT**

6.A BASIC TORQUE MEASUREMENT ..... 6.3

6.B TROUBLESHOOTING ..... 6.7

6.C PERIODIC INSPECTION AND MAINTENANCE

6.C.1 Inspection..... 6.8

6.C.2 Fluid Recharge..... 6.8

6.C.3 Reference Checking The Torque Measurement System ..... 6.8

6.C.4 Repair And Calibration ..... 6.9

**SECTION SEVEN: HYDRAULIC COMPONENT INFORMATION**

Illustration 1.A.1: KT20-50K Tong .....	1.3
Illustration 1.A.2: KT20-50K Dimensions .....	1.4
Illustration 1.A.3: KT20-50K Hazard Areas .....	1.5
Illustration 1.A.4: FARR® CE Nameplate.....	1.6
Illustration 2.B.1: Component ID 01 .....	2.3
Illustration 2.B.2: Component ID 02 .....	2.4
Illustration 2.B.3: Component ID 03 .....	2.5
Illustration 2.A.1: Sling Angle .....	2.6
Illustration 2.D.1: Lift Cylinder & Spring Hanger Installation .....	2.9
Illustration 2.D.2: Lift Cylinder Hydraulic Connection.....	2.10
Illustration 2.E.1: Standard Hydraulic Schematic.....	2.12
Illustration 2.E.2: Standard Hydraulic Schematic (CE Marked Tongs).....	2.13
Illustration 2.E.3: Standard Hydraulic Schematic - CLOSED CENTRE.....	2.14
Illustration 2.E.4: Standard Hydraulic Schematic - CLOSED CENTRE (CE Marked Tongs) .....	2.15
Illustration 2.E.5: Hydraulic Component Identification 01 .....	2.16
Illustration 2.E.6: Hydraulic Component Identification 02 .....	2.16
Illustration 2.E.7: Hydraulic Component Identification 03 .....	2.17
Illustration 2.E.8: Hydraulic Connections 01 .....	2.17
Illustration 2.E.9: Hydraulic Connections 02 .....	2.18
Illustration 2.F.1: Jaw Removal .....	2.20
Illustration 2.G.1: Tong Suspension Relative To Axial Centre .....	2.21
Illustration 2.G.2: Tong Suspension Relative To Vertical Centre.....	2.21
Illustration 2.G.3: Leveling Tong Using Turnbuckles .....	2.22
Illustration 2.H.1: Tong Motor Control Valve.....	2.24
Illustration 2.H.2: Tong Lift Cylinder Control Valves.....	2.24
Illustration 2.H.3: Shifting Gears .....	2.25
Illustration 2.I.1: Master Lifting Link .....	2.28
Illustration 2.I.2: Setting Backing Pin To “Make-up” Position .....	2.29
Illustration 2.I.3: Lift Cylinder Control - Raise .....	2.30
Illustration 2.I.4: Opening Tong Doors.....	2.30
Illustration 2.I.5: Motor Control - Make-up.....	2.31
Illustration 2.I.6: Motor Control - Releasing Jaws .....	2.32
Illustration 2.I.7: Lift Cylinder Control - Lower.....	2.32
Illustration 2.I.8: Setting Backing Pin To “Break-Out” Position.....	2.33
Illustration 2.I.10: Releasing Tong Jaws Following Break-out & Un-threading .....	2.34
Illustration 2.I.9: Rotation Control - Break-Out.....	2.34
Illustration 2.I.11: Lowering Tong Using Lift Cylinder Control .....	2.35
Illustration 3.E.1: Cage plate Cam Follower Lubrication.....	3.4
Illustration 3.E.2: Rotary Gear Lubrication .....	3.5
Illustration 3.E.3: Support Roller Lubrication.....	3.5
Illustration 3.E.4: Rotary IDler Lubrication .....	3.6
Illustration 3.E.5: Pinion Idler Lubrication.....	3.6
Illustration 3.E.6: Pinion Lubrication.....	3.7
Illustration 3.E.7: Clutch Shaft Lubrication .....	3.7
Illustration 3.E.8: Shifter Component Lubrication Access .....	3.8
Illustration 3.E.9: Jaw Roller Lubrication .....	3.8
Illustration 3.F.1: Brake Band Adjustment .....	3.9
Illustration 3.E.10: Door Spring Cylinder Lubrication .....	3.9
Illustration 3.F.2: Door Latch Adjustment Cams.....	3.10
Illustration 3.F.3: Door Alignment Measurement Points .....	3.11
Illustration 3.F.4: Door Alignment Adjustment Set Screws .....	3.11
Illustration 3.F.5: Shifter Detent Force Adjustment.....	3.12
Illustration 3.I.1: Cam Follower Installation - Bottom Plate .....	3.16
Illustration 3.I.2: Rotary Gear & Support Roller Installation .....	3.16
Illustration 3.I.3: Top Plate Cam Follower Installation .....	3.17
Illustration 3.I.4: Top Plate Fastener Exclusions .....	3.18
Illustration 3.I.5: Installation of Horizontal Cam Followers and Guides .....	3.18
Illustration 3.I.6: Support Roller - Brake band Weldment Installation .....	3.19
Illustration 3.I.7: Top & Bottom Cage plate Installation .....	3.20
Illustration 3.I.8: Door Spring Cylinder Post Installation.....	3.21
Illustration 3.I.9: Safety Door Valve Load Plunger Installation.....	3.22
Illustration 3.I.10: Hydraulic Safety Door Switch Installation.....	3.23
Illustration 3.I.11: Tong Assembly - Valve Handle Guard Installation (CE Marked Tongs).....	3.24
Illustration 3.L.1: Shipping Instructions - Pallet.....	3.32
Illustration 3.L.2: Shipping Instructions - Wrapping Chain Sling & Strapping To Pallet.....	3.33
Illustration 4.B.1: Relief Valve Troubleshooting - Temporary Gauge Installation .....	4.4

Continued on next page ...



Illustration 5.1: KT20-50K Gear Train Iso View.....	5.6
Illustration 5.2: KT20-50K Gear Train Top View.....	5.7
Illustration 5.3: KT20-50K Gear Train Side View .....	5.7
Illustration 5.4: Support Roller Exploded.....	5.8
Illustration 5.5: Support Roller.....	5.9
Illustration 5.6: Door Pivot Roller Exploded .....	5.10
Illustration 5.7: Door Pivot Roller .....	5.11
Illustration 5.8: Rotary Idler Exploded .....	5.12
Illustration 5.9: Rotary Idler .....	5.13
Illustration 5.10: Pinion Idler Exploded.....	5.14
Illustration 5.11: Pinion Idler .....	5.15
Illustration 5.12: Pinion Gear Assembly Exploded .....	5.16
Illustration 5.13: Pinion Gear Assembly .....	5.17
Illustration 5.14: Clutch Gear Assembly Exploded.....	5.18
Illustration 5.15: Clutch Gear Assembly .....	5.19
Illustration 5.16: Cam Follower Array Exploded.....	5.20
Illustration 5.17: Cam Follower Array .....	5.21
Illustration 5.18: Manual Shifter Assembly Exploded.....	5.22
Illustration 5.19: Manual Shifter Assembly .....	5.23
Illustration 5.20: Manual Shifter Assembly Exploded (CE-Marked) .....	5.24
Illustration 5.21: Manual Shifter Assembly (CE-Marked) .....	5.25
Illustration 5.22: Hydraulic Valve Mounts .....	5.26
Illustration 5.23: Tong Hangers .....	5.27
Illustration 5.24: Hydraulic Motor Assemblies Exploded .....	5.28
Illustration 5.25: Torque Gauge Mounts .....	5.30
Illustration 5.26: Brake Bands Exploded .....	5.32
Illustration 5.27: Brake Bands .....	5.33
Illustration 5.28: Cage Plate Exploded.....	5.34
Illustration 5.29: Cage Plate .....	5.35
Illustration 5.30: Control Valve Assembly Exploded.....	5.36
Illustration 5.31: Control Valve Assembly .....	5.37
Illustration 5.32: Door Assembly Exploded .....	5.38
Illustration 5.33: Door Assembly.....	5.39
Illustration 5.34: Safety Door Components Exploded .....	5.40
Illustration 5.35: Safety Door Components .....	5.41
Illustration 5.34: Safety Door Components Exploded .....	5.42
Illustration 6.A.1: Torque Gauge (For Illustration Purposes Only) .....	6.3
Illustration 6.A.2: Tension Load Cell.....	6.3
Illustration 6.A.3: Compression Load Cell.....	6.3
Illustration 6.A.4: Tension Load Cell Exploded.....	6.5
Illustration 6.A.5: Turn Counter Encoder Mount Exploded.....	6.6

## KT20-50 HYDRAULIC POWER TONG

The information presented in this document will provide setup, operating, and maintenance instructions for your KT20-50K power tong. Due to the wide variety of operating conditions, these instructions must be considered guidelines rather than absolute operating procedures. It is the responsibility of the user to use these guidelines together with an experienced manager to develop operating procedures that conform to all policies set forth by the operating authority (ies).

### IDENTIFICATION OF OF WARNINGS AND OTHER NOMENCLATURE OF IMPORTANCE USED IN THIS INSTALLATION GUIDE

McCoy uses three indicators to describe items of three degrees of importance.

A **HAZARD** to operators or equipment is represented by an exclamation point within a red triangle and identifies items of the highest importance. Failure to heed information identified by a **HAZARD** symbol may result in bodily injury, death, catastrophic equipment damage, or any combination of these. A **HAZARD** may also indicate the potential for dangerous environmental contamination.



**This identifies a HAZARD to operators or equipment**

A **WARNING** is represented by an exclamation point within an orange triangle, and contains information that will alert personnel to a potential safety hazard that is not life-threatening. A **WARNING** may also serve to alert the user to information critical to the correct assembly or operation of the equipment in use.



**This identifies a WARNING to users**

A **CAUTION** is represented by an exclamation point within a yellow triangle and highlights information that may aid the user during assembly or operation of your equipment. **CAUTIONS** are also used to ensure common errors are not made during assembly or operation of your equipment.



**This identifies a CAUTION to users**

Some sections of this technical manual apply only to “CE Marked” equipment. These sections will be clearly identified by the use of the phrase “applies to CE-marked tongs only”, or by use of the CE logo within an enclosed border.



**This identifies a section that only applies to CE-Marked equipment**

Observance of the following is the full responsibility of the user:

- all descriptions, information and instructions set out in this manual
- any regulation or requirement issued by an authority or agency which may influence operation, safety or integrity of the equipment that overrules the content of this document.
- any legal or other mandatory regulation in force governing accident prevention or environmental protection.



**SECTION 1: INTRODUCTION & SPECIFICATIONS**



**This page intentionally  
left blank**

Congratulations on the purchase of your McCoy KT20-50K 20" tong. This unit will provide you with years of outstanding performance. Simple maintenance and care will extend its life and ensure years of excellent performance and reliability. The setup, operating, and maintenance instructions in this manual will assist you in giving your equipment the care it requires. Please carefully read the manual before installing and using your equipment. Replacement parts are readily available from McCoy Global Canada in Edmonton, Alberta. Should you need replacement parts, or should you experience any difficulty not covered in this manual, please contact:

**McCoy Global Canada Corp.**

14755 121A Avenue  
Edmonton, Alberta  
Canada T5L 2T2

Phone: 780.453.3277

Fax: 780.455.2432

Email Engineering: [engFarr@mccoyglobal.com](mailto:engFarr@mccoyglobal.com)

Email Sales: [salesFarr@mccoyglobal.com](mailto:salesFarr@mccoyglobal.com)

Website: <http://www.mccoyglobal.com/drilling-completions>

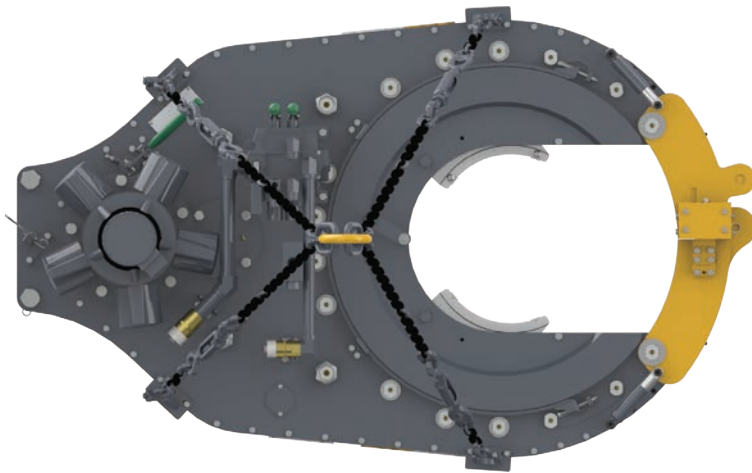


**ILLUSTRATION 1.A.1: KT20-50K TONG**

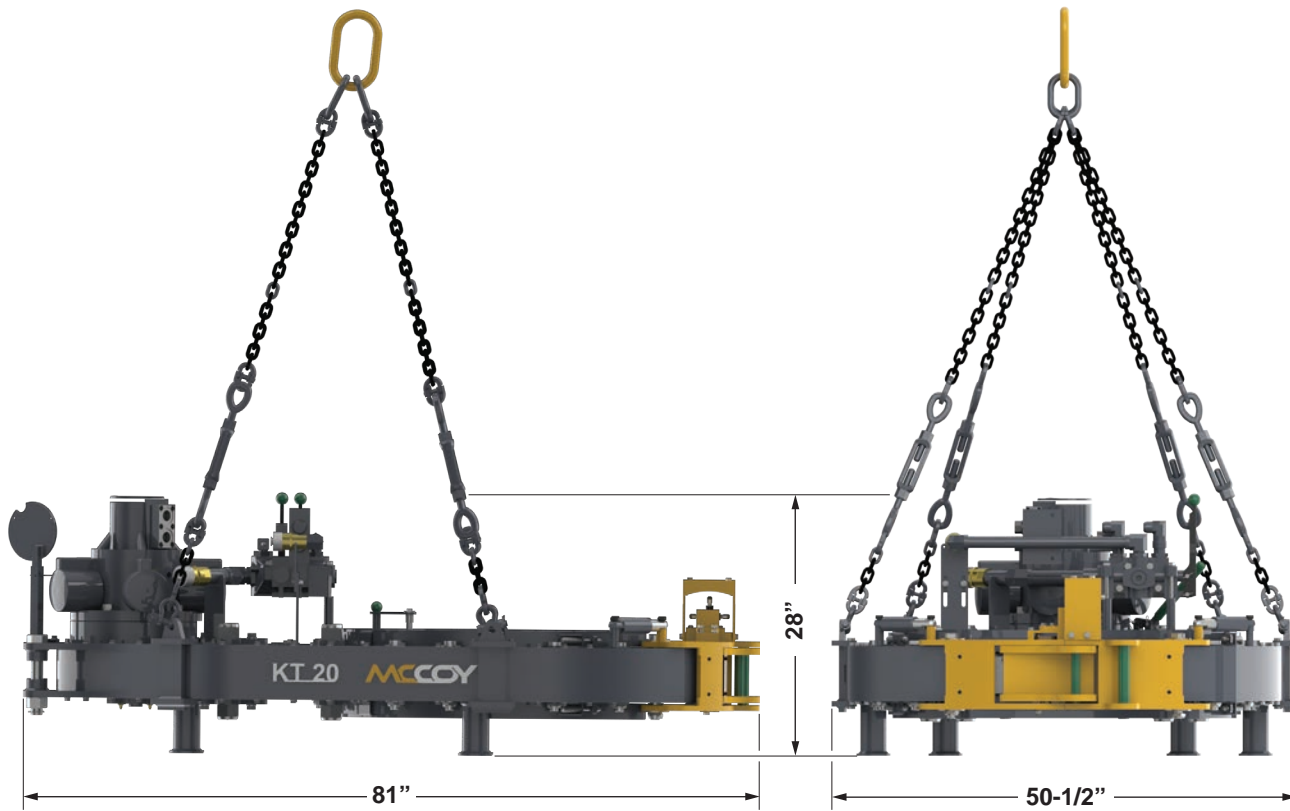
**Color Coding:**

**Green** = Handle or control, safe to grasp or manipulate

**Yellow** = Active or potential hazard. Use caution not to contact area especially when tong is rotating.



Shown with Staffa motor. Height with Rineer motor = 25-3/8" (64.5 cm)



**ILLUSTRATION 1.A.2: KT20-50K DIMENSIONS**



**ALL REPLACEMENT FASTENER (BOLTS, NUTS, CAP SCREWS, MACHINE SCREWS, ETC.) USED DURING MAINTENANCE OR OVERHAUL MUST BE GRADE 8 OR EQUIVALENT UNLESS OTHERWISE SPECIFIED.**



THIS PAGE ILLUSTRATES THE “SAFE TO HANDLE” AND “HAZARD” AREAS OF THIS EQUIPMENT

In addition to the **HAZARD** areas of this equipment that are coated **YELLOW**, the rotating cage plate assembly poses a significant hazard when the equipment is active. Keep hands clear of the cage plate when equipment is energized. **SAFE** areas to handle while the equipment is energized are indicated by **GREEN** coating

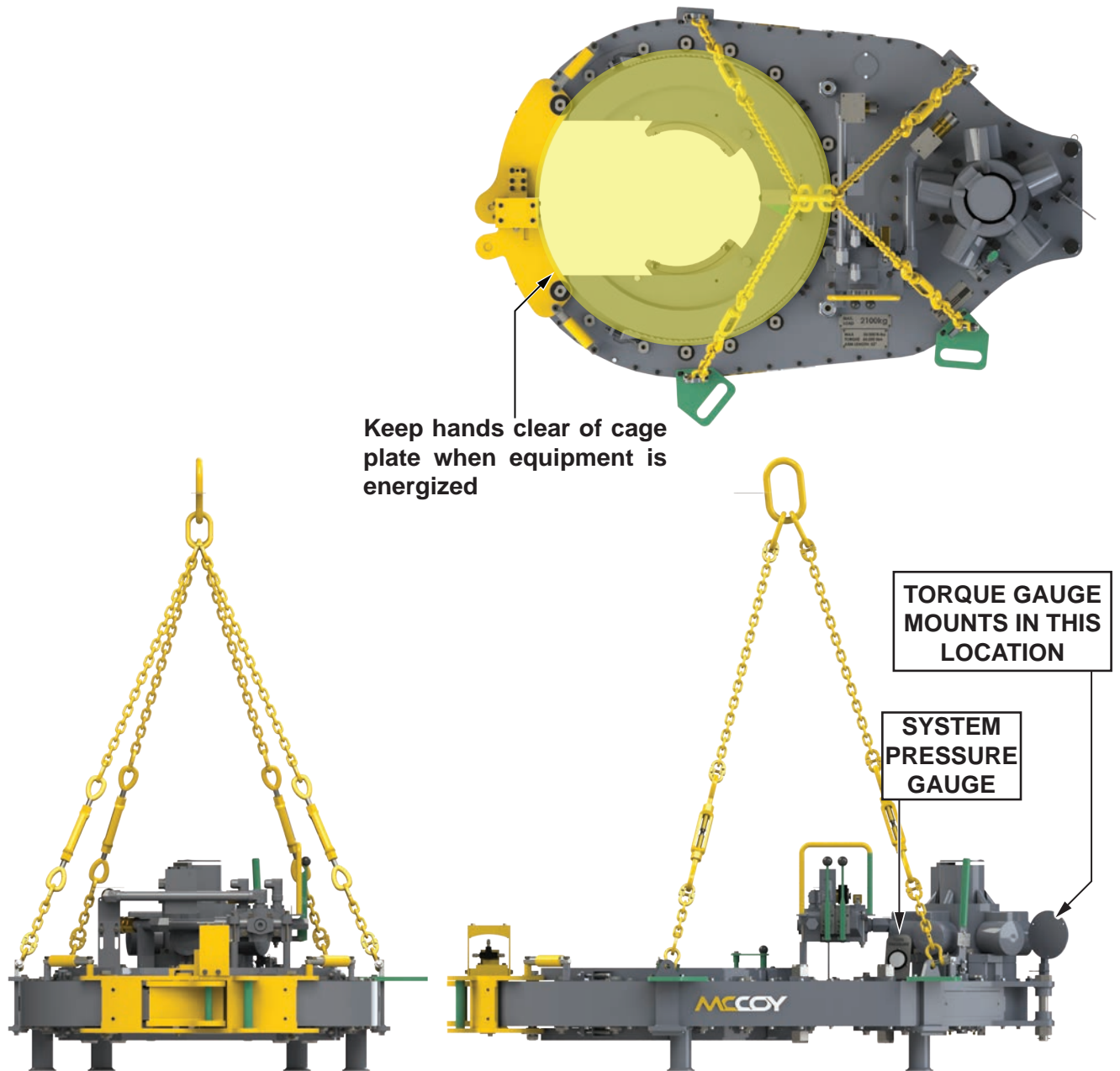
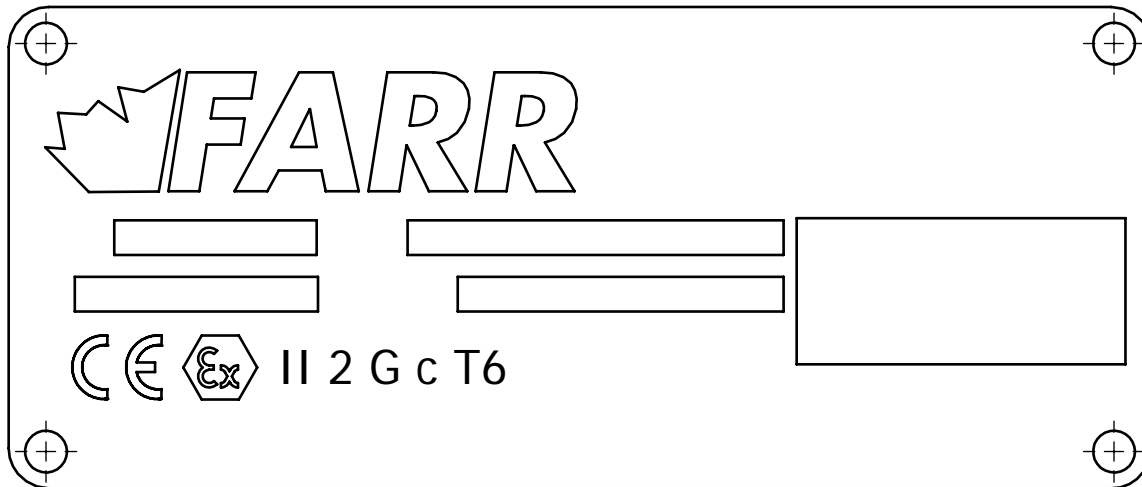


ILLUSTRATION 1.A.3: KT20-50K HAZARD AREAS



**ILLUSTRATION 1.A.4: FARR® CE NAMEPLATE**

**CE** CE compliant. Conforms with the essential requirements of the applicable Conformité Européenne directives.

**Ex** EU Explosive Atmosphere certified

**II** Equipment Group (surface, non-mining)

**2** Equipment Category - high level of protection

**GC** Gas Group (Acetylene & Hydrogen) - Certified for use in an acetylene / hydrogen environment

**T6** Maximum surface temperature of 85 °C.

#### **Lubricant Standards:**

McCoy recommends using good-quality hydraulic fluid with a viscosity of ISO 68. Allowing adequate time for the hydraulic fluid to reach an operating temperature of 38°C to 48°C (100°F to 118°F) permits the fluid to operate at its optimum operating viscosity, and maximizes the service life of the fluid and integrity of hydraulic components. System temperature above 54°C (130°F) exceeds the temperature that allows minimum operating viscosity of the fluid. Running your hydraulic system at temperatures continuously exceeding 60°C (140°F) will lead to premature component wear, leaking seals, slow hydraulic system response, and more frequent replacement of the hydraulic fluid. A hydraulic fluid cooler is recommended where operating temperatures are expected to exceed the recommended maximum.

McCoy recommends use of a good-quality EP synthetic multi-purpose grease with an NLGI consistency grade of "2" and an NLGI performance grade of "GC-LB" for general lubrication of bearings and metal-to-metal contact.



**Torque Table**

Please note that these are ideal values. Actual achieved torque is highly dependant upon tong efficiency and final position of rotary gear when full torque load is reached. Maximum torque is only available in low gear and full motor displacement.

Staffa HMB 80 Motor					
Pressure		High Gear		Low Gear	
PSI	MPa	Lbs-Ft	NM	Lbs-Ft	NM
1000	6.895	2500	3390	15800	21422
1500	10.34	4200	5694	27400	37149
2000	13.79	6000	8135	39100	53012
2500	17.24	7800	10575	50700	68740

Rineer GA125 Motor					
Pressure		High Gear (lbs-ft)		Low Gear (lbs-ft)	
PSI	MPa	Lbs.-Ft.	Nm	Lbs.-Ft.	Nm
1000	6.895	2300	3118	14600	19795
1500	10.34	3900	5288	25500	34573
2000	13.79	5600	7593	36300	49216
2650	18.27	7700	10440	50300	68198

**MAXIMUM RATED TORQUE: 50000 LBS-FT (67790 NM)**  
**MAXIMUM HYDRAULIC SUPPLY PRESSURE: 3000 PSI (20.684 MPA)**  
**McCoy sets the system relief valve to the pressure required to deliver maximum rated torque.**

**Speed Table**

Flow (USGPM/LPM)	Low Gear (RPM)	High Gear (RPM)
10	1	8
20	3	17
40	5	32
60	7	49

Maximum hydraulic requirements	60 GPM (227.1 LPM)
	3000 PSI (20.684 MPa)
Maximum dimensions:	
Length (door closed)	81 in / 2.057 m
Height (Staffa motor, chain sling not inc.)	28 in / 0.711 m
Height (Rineer motor, chain sling not inc.)	25- <sup>3</sup> / <sub>8</sub> in / 0.645 m
Width	50- <sup>1</sup> / <sub>2</sub> in / 1.283 m
Maximum Elevator Diameter	Unlimited (tong comes off pipe)
Space Required On Pipe	10 in / 254 mm
Torque Arm Length (Pipe center to anchor center)	52 in / 1321 mm
Dead Weight (Approximate)	3400 lbs / 1545 kg (jaws not included)
Sound Level (dBa)	97 dB A @ 1m / 96 dB C @ 1m
Tong Jaws available (inches)	All standard sizes from 7" to 20" (See Pg. 2.17)
Recommended Spring Hanger	85-0106XXH (Max Capacity = 2400 lbs / 1091 kg)



REPLACEMENT FASTENERS (BOLTS, NUTS, CAP SCREWS, MACHINE SCREWS, ETC.) MUST BE GRADE 8 OR EQUIVALENT (WHERE REQUIRED).



**This page intentionally  
left blank**



**SECTION 2: COMMISSIONING & OPERATION**



**This page intentionally  
left blank**

Adequate setup and proper hydraulic connections are essential in ensuring reliable operation of your tong. For best results and long term reliability, read and obey the start-up instructions in this section.

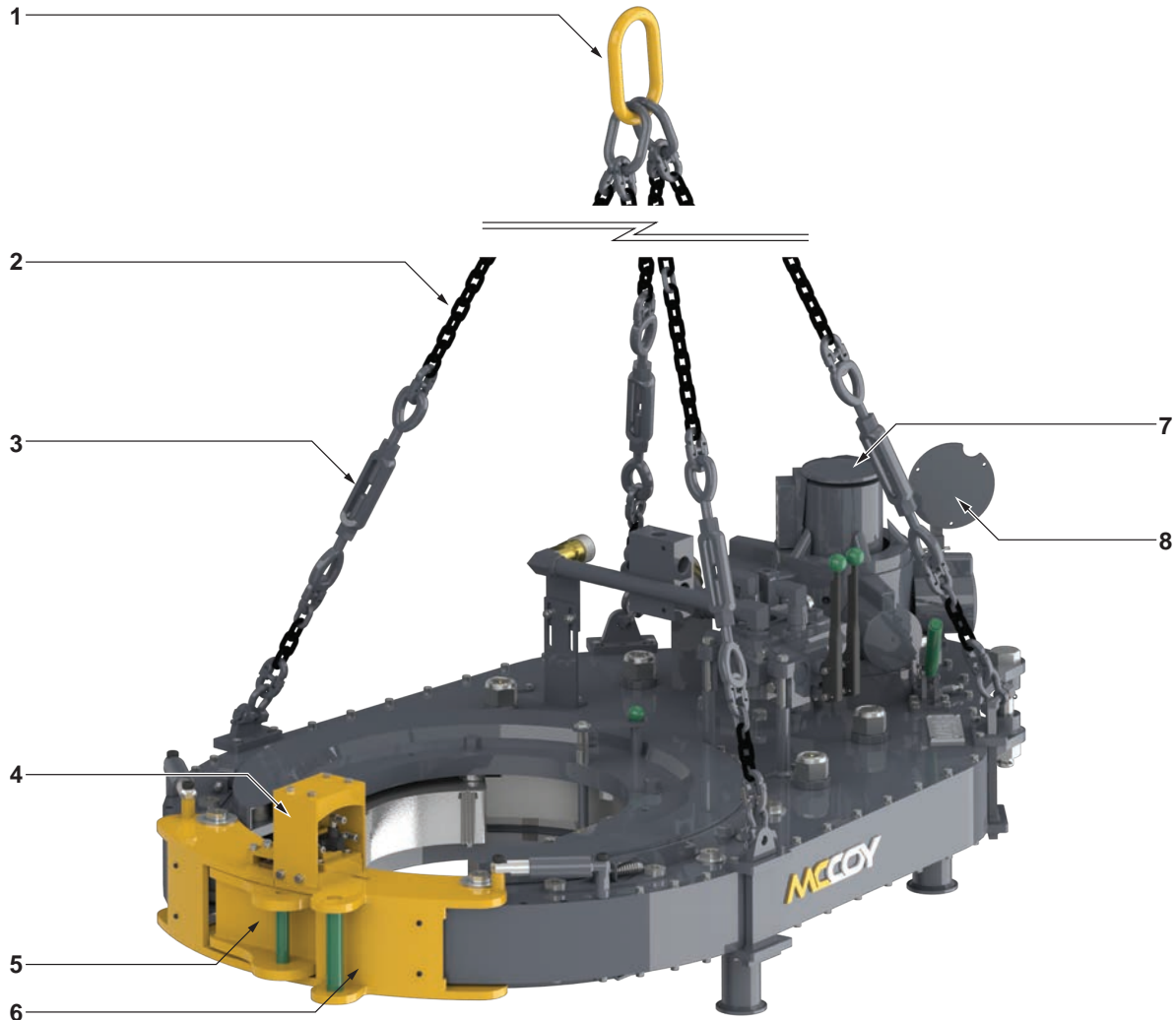
2.A INITIAL RECEIPT AND INSPECTION OF EQUIPMENT



**YOUR EQUIPMENT HAS BEEN THOROUGHLY TESTED AND INSPECTED AT THE FACTORY. HOWEVER, MCCOY ADVISES INSPECTING YOUR EQUIPMENT FOR SHIPPING DAMAGE UPON RECEIPT AND TESTING YOUR TONG BEFORE RELEASING TO AN OPERATIONAL ENVIRONMENT.**

Perform a visual inspection following removal of all packaging material. Immediately identify any shipping damage to the shipping company, and correct all damage before connecting equipment to a hydraulic power source.

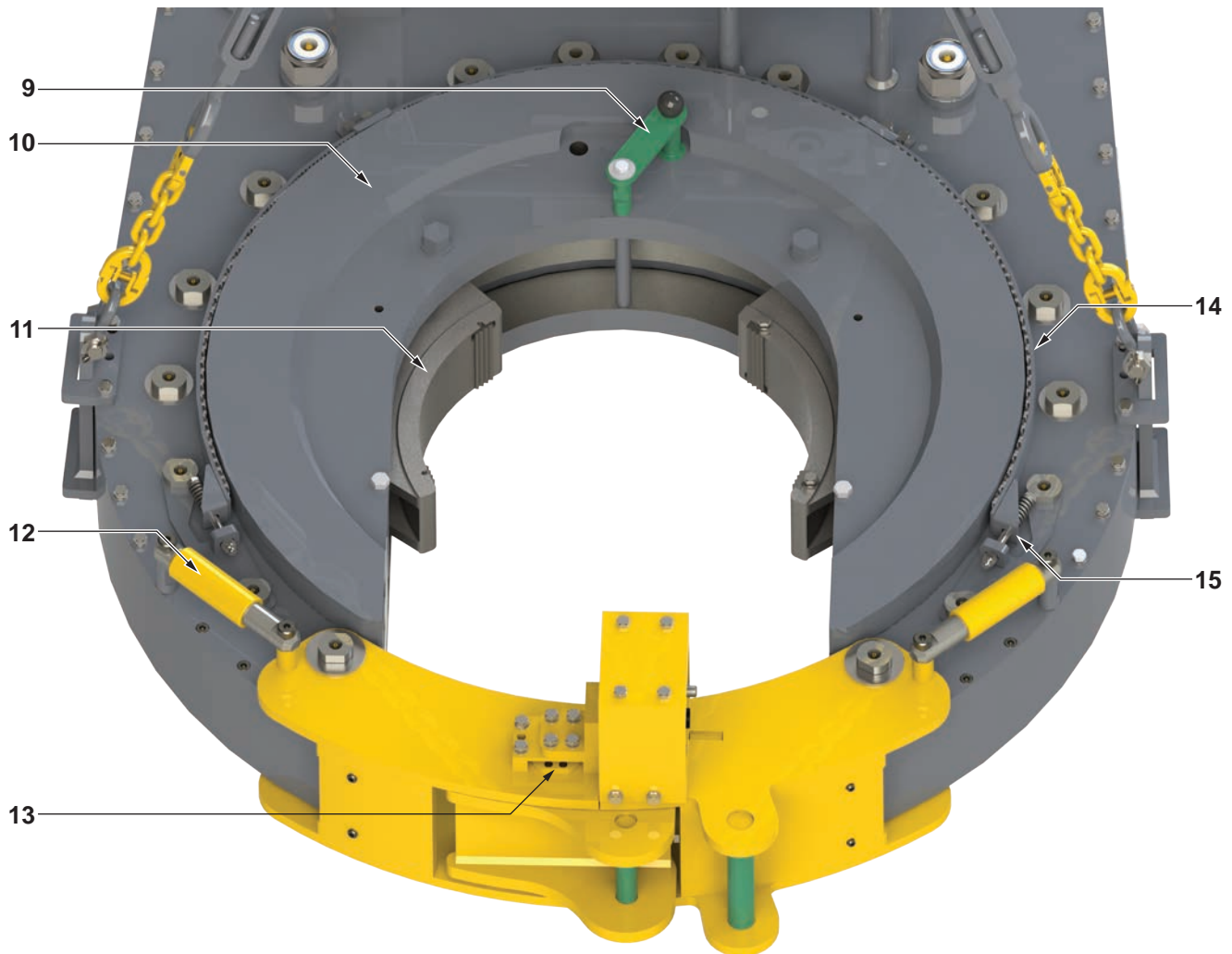
2.B MAJOR COMPONENT IDENTIFICATION



**ILLUSTRATION 2.B.1: COMPONENT ID 01**

Item	Description
1	Master lifting link
2	Chain sling
3	Chain sling leveling turnbuckle
4	Safety door switch assembly
5	Tong door latch
6	Tong doors
7	Hydraulic motor
8	Torque gauge mounting plate

2.B MAJOR COMPONENT IDENTIFICATION (CONTINUED):



**ILLUSTRATION 2.B.2: COMPONENT ID 02**

Item	Description
9	Backing pin assembly
10	Cage plate assembly
11	Tong jaws with die inserts
12	Tong door spring cylinder
13	Door latch adjustment cam
14	Brake band
15	Brake band adjustment

2.B MAJOR COMPONENT IDENTIFICATION (CONTINUED):



**ILLUSTRATION 2.B.3: COMPONENT ID 03**

Item	Description
16	Valve bank assembly
17	Chain sling lifting bracket
18	Manual shift assembly
19	Motor mount
20	Clutch & shifting shaft access panel

## 2.C SLING / LOAD BEARING DEVICE SAFETY



THE SUPPLIED LOAD-BEARING DEVICE (CHAIN SLING, RIGID SLING, SPREADER BAR ASSEMBLY, FRAME, OR ANY OTHER DEVICE THAT BEARS THE PARTIAL OR TOTAL WEIGHT OF THE EQUIPMENT DESCRIBED IN THIS MANUAL) HAS BEEN SPECIFIED OR DESIGNED TO SUPPORT THE EQUIPMENT DESCRIBED IN THIS DOCUMENT. MCCOY WILL NOT GUARANTEE THE ABILITY OF THE LOAD-BEARING DEVICE TO SUPPORT ANY OTHER PART, ASSEMBLY OR COMBINATION OF PARTS AND ASSEMBLIES, OR ANY ADDITIONS TO THE EQUIPMENT DESCRIBED IN THIS MANUAL THAT ADD WEIGHT TO THE EQUIPMENT, UNLESS SUPPLIED BY MCCOY.

MCCOY GLOBAL DOES NOT GUARANTEE THE INTEGRITY OF MODIFIED OR DAMAGED LOAD-BEARING DEVICES, UNLESS THOSE MODIFICATIONS ARE PERFORMED BY MCCOY.

McCoy Global recommends following an industry-accepted standard such as OSHA, ASME B30.9-2006, or manufacturer's guidelines when performing any rigging and overhead lifting. Use by untrained persons is hazardous. Improper use will result in serious injury or death. Do not exceed rated capacity. Slings will fail if damaged, abused, misused, overused, or improperly maintained.

- Only grade 80 or grade 100 alloy chain should be used for overhead lifting applications.
- Working Load Limit (WLL) is the maximum allowable load in pounds which may be applied to the load-bearing device, when the device is new or in "as new" condition, and when the load is uniformly and directly applied. The WLL must never be exceeded.
- Working Load Limit (WLL) is the maximum working load for a specific minimum sling angle, measured from the horizontal plane. The Working Load Limit is identified on the sling.
- The Working Load Limit or Design factor may be affected by wear, misuse, overloading, corrosion, deformation, intentional alterations, sharp corner cutting action and other use conditions.
- Shock loading and extraordinary conditions must be taken into account when selecting alloy chain slings.
- See OSHA Regulation for Slings 1910.184, ANSI/ASME B30.9-"SLINGS", ANSI/ASME B30.10-"HOOKS" and ANSI/AMSE B30.26 "RIGGING HARDWARE" for additional information.



THE MINIMUM SLING ANGLE (THE ANGLE OF THE LEG OF THE SLING MEASURED FROM THE HORIZONTAL) MUST NEVER FALL LOWER THAN THE ANGLE SPECIFIED FOR THE SLING IN USE

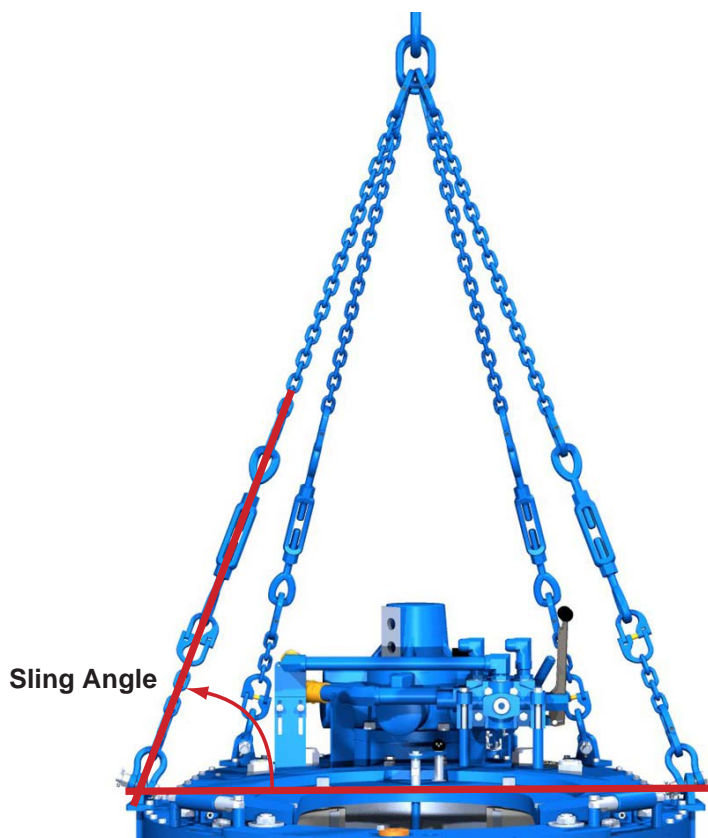


ILLUSTRATION 2.A.1: SLING ANGLE



2.C SLING / LOAD BEARING DEVICE SAFETY (CONTINUED):

2.C.1 Inspection Of Slings

McCoy Global strongly recommends the following practices:

A complete inspection of new load-bearing devices and attachments shall be performed by a qualified, designated person prior to initial use. Each link and component shall be examined individually, taking care to expose and examine all surfaces including the inner link surface. The sling shall be examined for conditions such as those listed in the removal criteria below. In addition, daily inspection of slings, fastenings and attachments shall be performed by a designated person. If damage or defects are found at either inspection, the damaged or defective component shall be quarantined from service until it can be properly repaired or replaced.

Removal Criteria:

A load-bearing device shall be removed from service if conditions such as the following are present:

- Missing or illegible sling identification.
- Cracks or breaks
- Evidence of tampering is seen - sling tag has been modified or obscured, or tamper-proof nuts are missing.
- Signs of impact on load-bearing components, including spreader bars, lifting lugs, rigid slings & rigid sling weldments, and legs & leg mounts.
- Broken or damaged welds.
- Excessive wear, nicks, or gouges. Refer to the chart below to ensure minimum thickness on chain links supplied is not be below the values listed:

Minimum Allowable Chain Link Thickness at Any Point			
Nominal Chain Size		Minimum Thickness	
Inches	MM	Inches	MM
7/32	5.5	0.189	4.80
9/32	7	0.239	6.07
5/16	8	0.273	6.93
3/8	10	0.342	8.69
1/2	13	0.443	11.26
5/8	16	0.546	13.87
3/4	20	0.687	17.45
7/8	22	0.750	19.05
1	26	0.887	22.53
1-1/4	32	1.091	27.71
<b>Refer To ASME B30.9</b>			

- Stretched, bent, twisted, or deformed chain links or components.
- Evidence of heat damage.
- Excessive pitting or corrosion.
- Lack of ability of chain or components to hinge (articulate) freely.
- Weld splatter.
- For hooks, removal criteria as stated in ASME B30.10
- Other conditions, including visible damage, that cause doubt as to the continued use of the sling.

Inspect all lugs and fixing points for signs of elongation and/or bending, or for material build-up around the hole. Repair or replace components that appear distorted. Ensure all hardware is tight and in good condition. Replace missing hardware if necessary. All hardware must be free of rust and corrosion.

Additional inspections shall be performed during sling use where service conditions warrant. Periodic inspection intervals shall not exceed one year. The frequency of periodic inspections should be based on:

- Frequency of use of the load-bearing device.
- Severity of service conditions
- Nature of lifts being made
- Experience gained on the service life of load-bearing devices used in similar circumstances.

Guidelines for the interval are:

- Normal Service - yearly
- Severe Service - monthly to quarterly
- Special Service - as recommended by a qualified person

**2.C.1 Inspection Of Slings (Continued):**

Units designed and manufactured in accordance with EN 12079 and DNV 2.7-1 should be tested and examined in accordance with the following schedule of examination and test. The user of the load-bearing device shall place a permanent placard or plate upon which the type and date of the last test shall be recorded. To avoid confusion, the plate shall not carry the date of the next test or examination, only the most recent.

Test / Examination				
TIME / INTERVAL	LIFTING TESTS <sup>1</sup>	NON-DESTRUCTIVE EXAMINATION (NDE) OF LIFTING POINTS	THOROUGH VISUAL EXAMINATION	SUFFIX TO BE MARKED ON PLATE ATTACHED TO UNIT
Initial Certification By McCoy	YES	YES	YES	T
Interval Not Exceeding 12 Months	At the discretion of inspection body	At the discretion of inspection body	YES	T or VN <sup>3</sup>
Interval Not Exceeding 60 Months	At the discretion of inspection body	YES	YES	T or VN
Following Substantial Repair or Alteration <sup>4</sup>	YES	YES	YES	T

1. Lifting test as per S 7.3 BS EN 12079 or DNV 2.7-1 May 1995  
 2. T = Proof Test, non-destructive examination; VN = non destructive examination and visual examination; V = visual examination.  
 3. Dependant upon whether non-destructive examination has been carried out.  
 4. For the purposes of this standard, a substantial repair or modification is defined as any repair and/or modification that has been carried out which may, in the opinion of the inspection body, affect the load-bearing elements of the container or lifting device, or elements that contribute directly to its structural integrity.



**OBSERVED OR SUSPECTED MECHANICAL DAMAGE TO A LOAD-BEARING DEVICE, OR OVERLOADING OF A THE LOAD-BEARING DEVICE HAS BEEN OVERLOADED REQUIRES REMOVAL FROM SERVICE AND QUARANTINING OF THE DEVICE UNTIL RECERTIFIED**

Written records of the most recent periodic inspection shall be maintained, and shall include the condition of the sling.

**2.C.2 Proper Use Of Load-Bearing Devices**

Whenever any load-bearing device is used, the following practices shall be observed.

- Load-bearing devices that are damaged or defective shall not be used.
- Slings shall not be shortened with knots or bolts or other makeshift devices.
- Sling legs shall not be kinked.
- Load-bearing devices shall not be loaded in excess of their rated capacities.
- Slings shall be securely attached to their load.
- Load-bearing devices shall be protected from snagging, and shall not be further obstructed by any object.
- Suspended loads shall be kept clear of all obstruction.
- All employees shall be kept clear of loads about to be lifted and of suspended loads.
- Hands or fingers shall not be placed between the sling and its load while the sling is being tightened around the load.
- Shock loading is prohibited.
- Do not stand directly under a load during lifting.

**2.C.3 Storage Of Load-Bearing Devices**

Proper storage of out-of-service load bearing devices is important to ensure full integrity of the device once it is returned to service. McCoy recommends observing the following practices.

- Wipe off all excess grease. Use a solvent-based cleaner on rags to wipe all external surfaces to remove residual grease or hydraulic fluid. Once the outside surfaces have been de-greased, wipe all external surfaces with clean water to remove residual solvent.
- McCoy recommends that an anti-corrosive agent such as Tectyl® 506 be applied to all external surfaces. Refer to manufacturer data sheets for proper application and safety information. Allow the anti-corrosive coating ample time to dry - refer to manufacturer data sheets for drying times at room temperature.
- Store in a clean, dry location. When returning to service, note that a full inspection of the device must be performed.



**ENSURE CHAINS DO NOT BECOME ENTANGLED IN ANY EQUIPMENT SUPERSTRUCTURE WHEN USING CHAIN SLINGS TO HOIST EQUIPMENT.**

**2.D LIFT CYLINDER INSTALLATION**

The lift cylinder is not orientation-specific; that is, the lift cylinder will function the same way independent of which end is connected to the crane and which end is connected to the main lifting lug of the tong (or the spring hanger, if used). However, McCoy recommends orienting the lift cylinder with the hydraulic hose connection at the bottom of the cylinder to ensure the hose is not stressed when cylinder is at full extension.



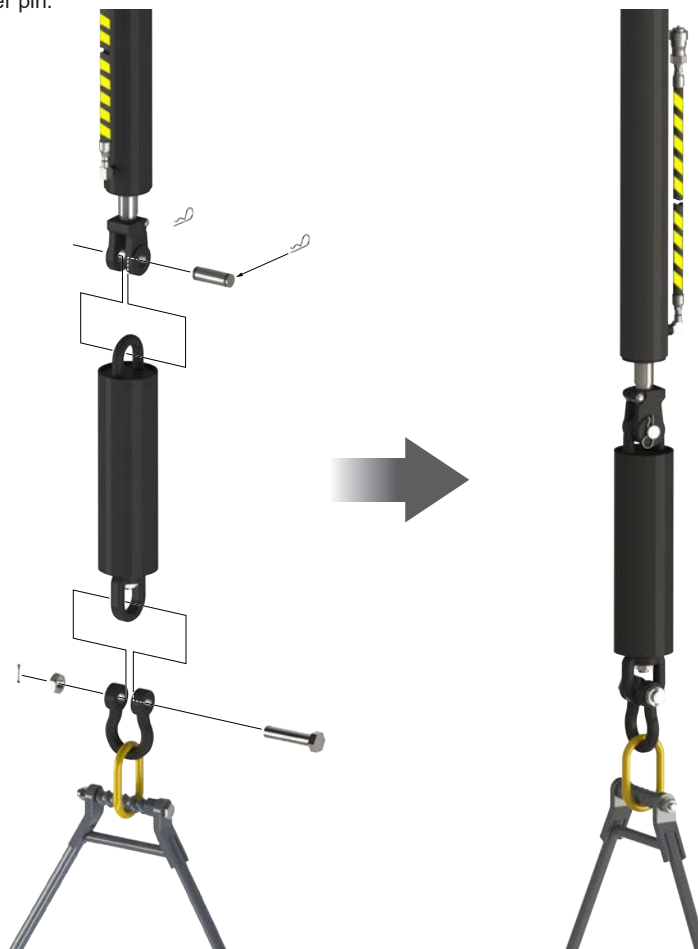
**TEST LIFT CYLINDER BEFORE INSTALLATION. REFER TO THE LIFT CYLINDER TECHNICAL MANUAL FOR DETAILED TESTING AND OPERATING PROCEDURES, AND DETAILED SAFETY GUIDELINES.**



**IF USING A SPRING HANGER ITS WEIGHT MUST BE ACCOUNTED FOR WHEN CALCULATING TOTAL SUSPENDED WEIGHT.**

**2.D.1 Installation Procedure**

1. Use a crane to hoist the lift cylinder by the shackle, ensuring the hydraulic hose connection is at the bottom of the cylinder when it is hoisted.
2. Remove the two R-clips securing the clevis pin, and remove the clevis pin.
3. Orient the spring hanger so the piston will extend down during thread make-up, preventing water and debris from gathering around the seal.
4. Place the welded U-connection inside the clevis. Replace the clevis pin, and secure the clevis pin with the two R-clips.
5. Hoist the lift cylinder and spring hanger.
6. Place a 1" shackle around the master lifting link on the tong sling. Secure the shackle to the extending end of the spring hanger using the 1- $\frac{1}{8}$ " UNC x 4- $\frac{3}{4}$ " modified hex bolt and 1- $\frac{1}{8}$ " UNC hex jam nut. Secure the jam nut to the bolt using a  $\frac{3}{16}$ " x 1- $\frac{1}{4}$ " cotter pin.



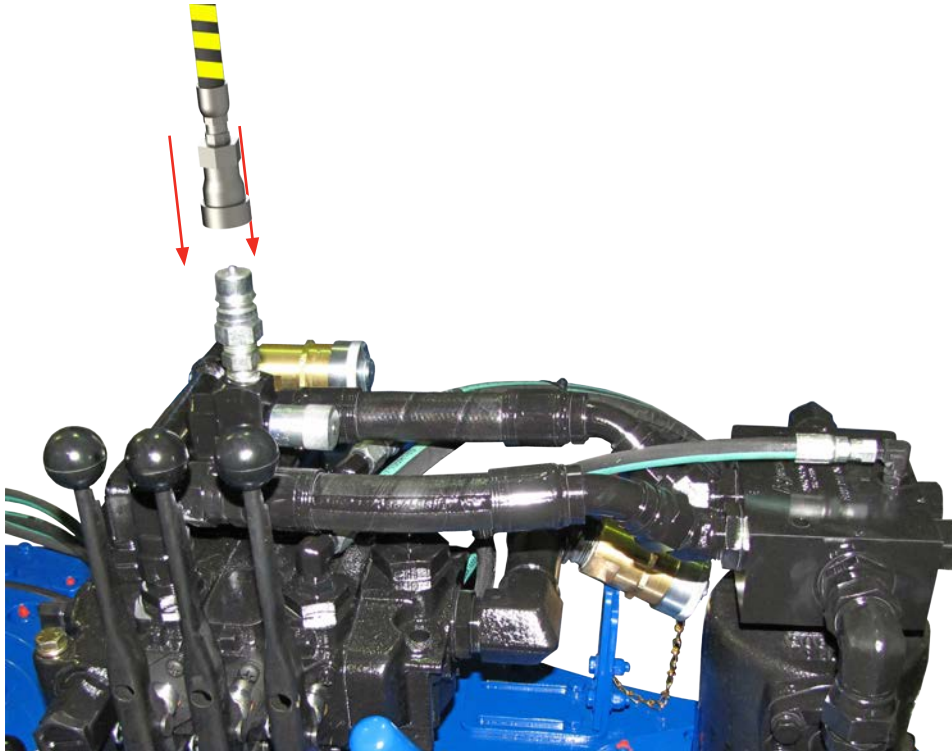
**ILLUSTRATION 2.D.1: LIFT CYLINDER & SPRING HANGER INSTALLATION**

### 2.D.2 Lift Cylinder Connection

Inspect the hydraulic hose before connection, ensuring the line is free of ruptures, cracks, cuts, or other damage. Inspect the female quick-connect fitting to ensure it is free from damage. Connect the female quick-connect on the lift cylinder hydraulic hose to the male quick-connect fitting attached to the needle valve on the tong valve bank. Once the fitting has snapped into place give the hydraulic line a light tug upwards to ensure the fitting is securely seated.

If not already done, connect the main hydraulic supply to the power tong (see subsection 2.E.3 for proper hydraulic connection procedure). Energize the hydraulic supply to the power tong.

Lift the power tong approximately three inches off the work surface, and suspend the tong for approximately thirty seconds. Following the suspension alternately lift and lower the tong slightly to confirm that lift and lower functions each operate correctly.



**ILLUSTRATION 2.D.2: LIFT CYLINDER HYDRAULIC CONNECTION**

### 2.D.3 Lift Cylinder Safety



**A CLEARLY IDENTIFIED REMOTE POWER PACK EMERGENCY STOP MUST BE INSTALLED IN THE IMMEDIATE VICINITY OF THE TONG OPERATOR.**

McCoy Global recommends following an industry-accepted standard such as OSHA, ASME B30.9-2006, or manufacturer's guidelines when performing any rigging and overhead lifting. Use by untrained persons is hazardous. Improper use will result in serious injury or death. Do not exceed rated capacity.

Working Load Limit (WLL) is the maximum allowable load in pounds which may be applied to the load-bearing device, when the device is new or in "as new" condition, and when the load is uniformly and directly applied. The WLL must never be exceeded.

The Working Load Limit or Design factor may be affected by wear, misuse, overloading, corrosion, deformation, intentional alterations, sharp corner cutting action and other use conditions.

See OSHA Regulation for Slings 1910.184, ANSI/ASME B30.9-"SLINGS", ANSI/ASME B30.10-"HOOKS" and ANSI/AMSE B30.26 "RIGGING HARDWARE" for additional information.

The flexible line providing hydraulic power to the lift cylinder has been equipped with abrasion-resistant, high visibility protective wrap. The high visibility wrap allows operators to easily see monitor the position of the hydraulic line at all times, and can easily see if the line appears to become entangled or snagged.



**IMMEDIATELY CEASE LIFT CYLINDER OPERATION IN THE EVENT OF ENTANGLEMENT OF THE HYDRAULIC LINE WITH FIXED RIG COMPONENTS OR TONG SUPERSTRUCTURE.**

**2.D.3 Lift Cylinder Safety (continued):**

The protective wrap also prevents wear of the hydraulic line through abrasion. Do not remove the protective wrap from the lift cylinder line, and replace protective wrap if it is missing, torn, or split. Regardless of use or condition, the hydraulic line supplying the lift cylinder must be replaced every two years.

**REPLACE LIFT CYLINDER HYDRAULIC LINE EVERY TWO YEARS**

The control valve section on the power tong is equipped with an internal check valve, preventing sudden drop of the tong in the event of hydraulic power failure. A speed-limiting orifice is installed in the breather port of the lift cylinder. The orifice prevents sudden drop of the lift cylinder in the event of a ruptured hydraulic line, limiting the speed at which the cylinder extends and the tong drops to a safe rate. Do not remove the speed-limiting orifice, and only replace with an identical orifice supplied by McCoy.

**DO NOT REMOVE THE SPEED-LIMITING ORIFICE FROM THE LIFT CYLINDER BREATHER PORT**

The working load limit (WLL) is clearly stenciled on to the side of the lift cylinder. Do not use lift cylinder if the WLL stencil has been rubbed off or intentionally removed. Locate the test certificate that accompanied the cylinder to the job site or, if necessary, obtain a copy of the test certificate from the location at which the original certificate has been stored. The lift cylinder must be clearly re-marked with the WLL before it is released to an operating environment.

**DO NOT USE A LIFT CYLINDER WITH A MISSING OR DEFACED WLL STENCIL.**

2.E HYDRAULICS

2.E.1 Hydraulic Schematics

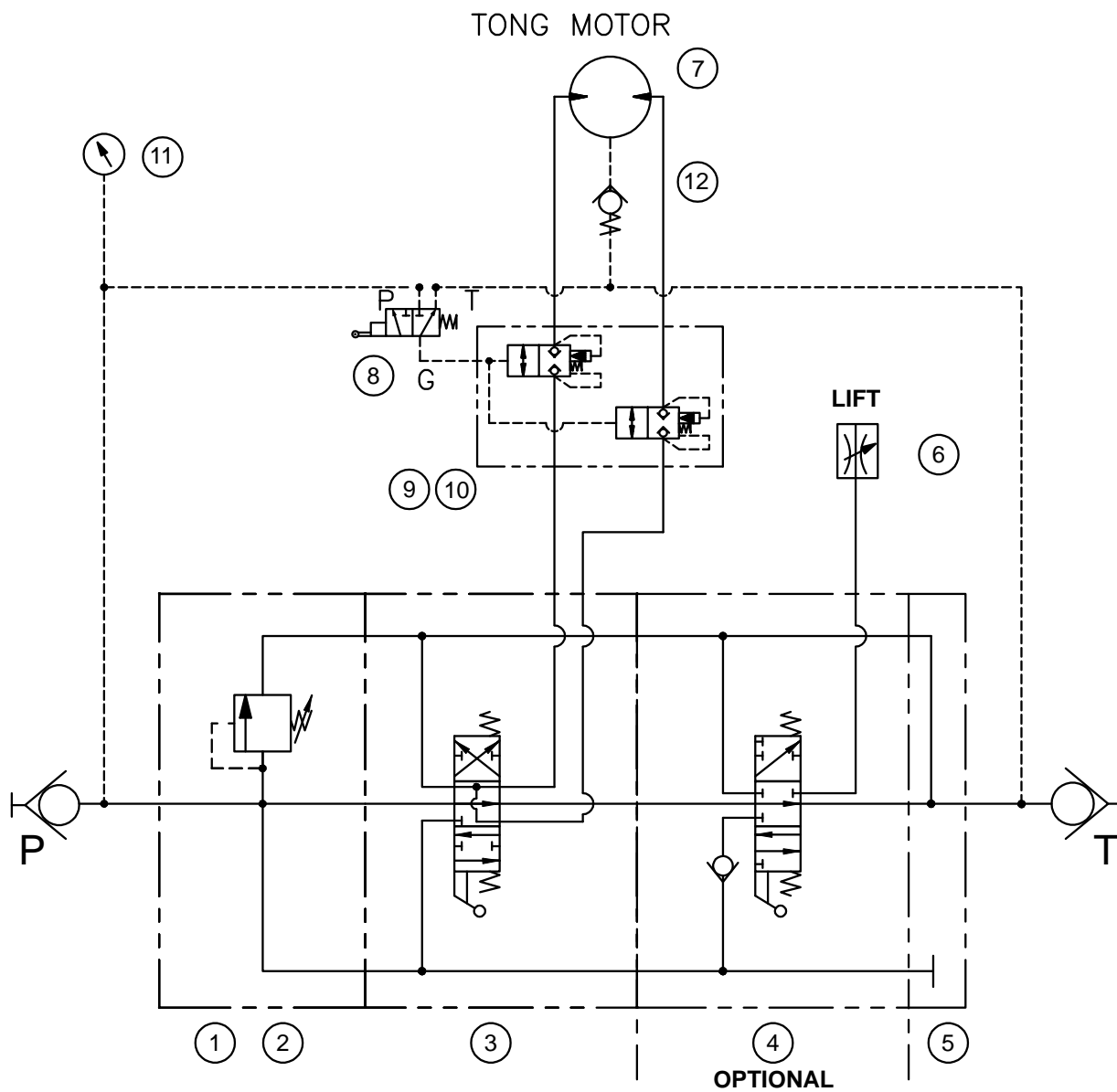


ILLUSTRATION 2.E.1: STANDARD HYDRAULIC SCHEMATIC

ITEM	QTY	DESCRIPTION	PART NUMBER
1	1	Inlet valve	10-9016
2	1	Relief valve	10-0062
3	1	Motor section valve	10-9014
4	1	Lift section valve	10-9015
4A	1	Lift cylinder section (optional) CE-marked tongs	10-9019
5	1	Outlet valve	10-0086
5A	1	Outlet valve CLOSED CENTRE TONGS ONLY	08-1825
6	1	1/2" needle valve	08-0066
Continued on next page			

2.E.1 Hydraulic Schematics (Continued):

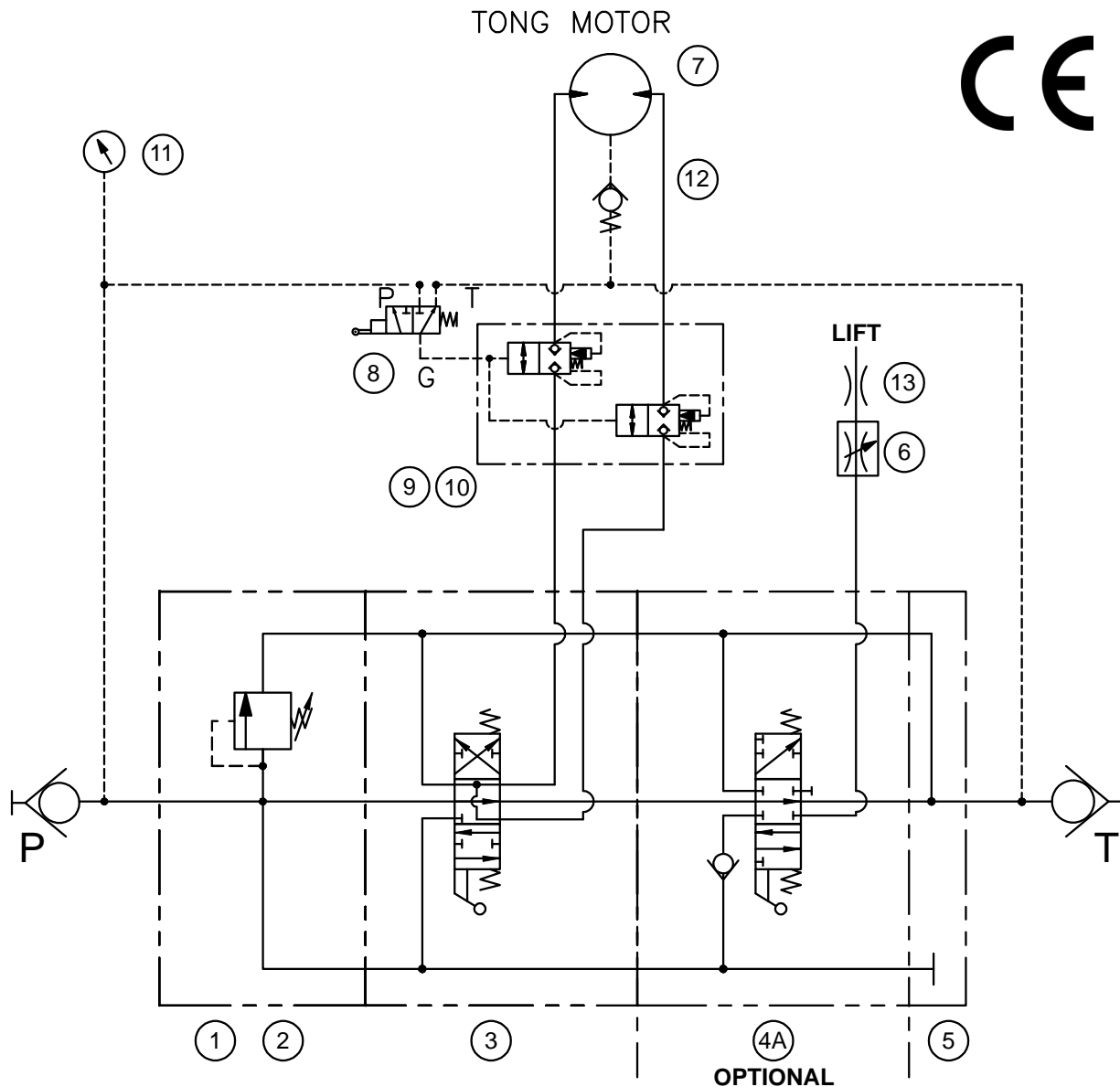


ILLUSTRATION 2.E.2: STANDARD HYDRAULIC SCHEMATIC (CE MARKED TONGS)

Hydraulic Component List Continued:			
ITEM	QTY	DESCRIPTION	PART NUMBER
7	1	Staffa hydraulic motor	87-0210B
	1	Optional: Rineer hydraulic motor	87-0150
8	1	Safety door switch	08-0337M
9	2	Safety door relief valve	08-1625
10	1	Safety door valve block	101-0727
11	1	0 - 3000 pressure gauge (not shown)	02-0245
12	1	Check valve (optional)	Varies with application
13	1	Lift cylinder orifice	CE-ORIFICE

2.E.1 Hydraulic Schematics (Continued):

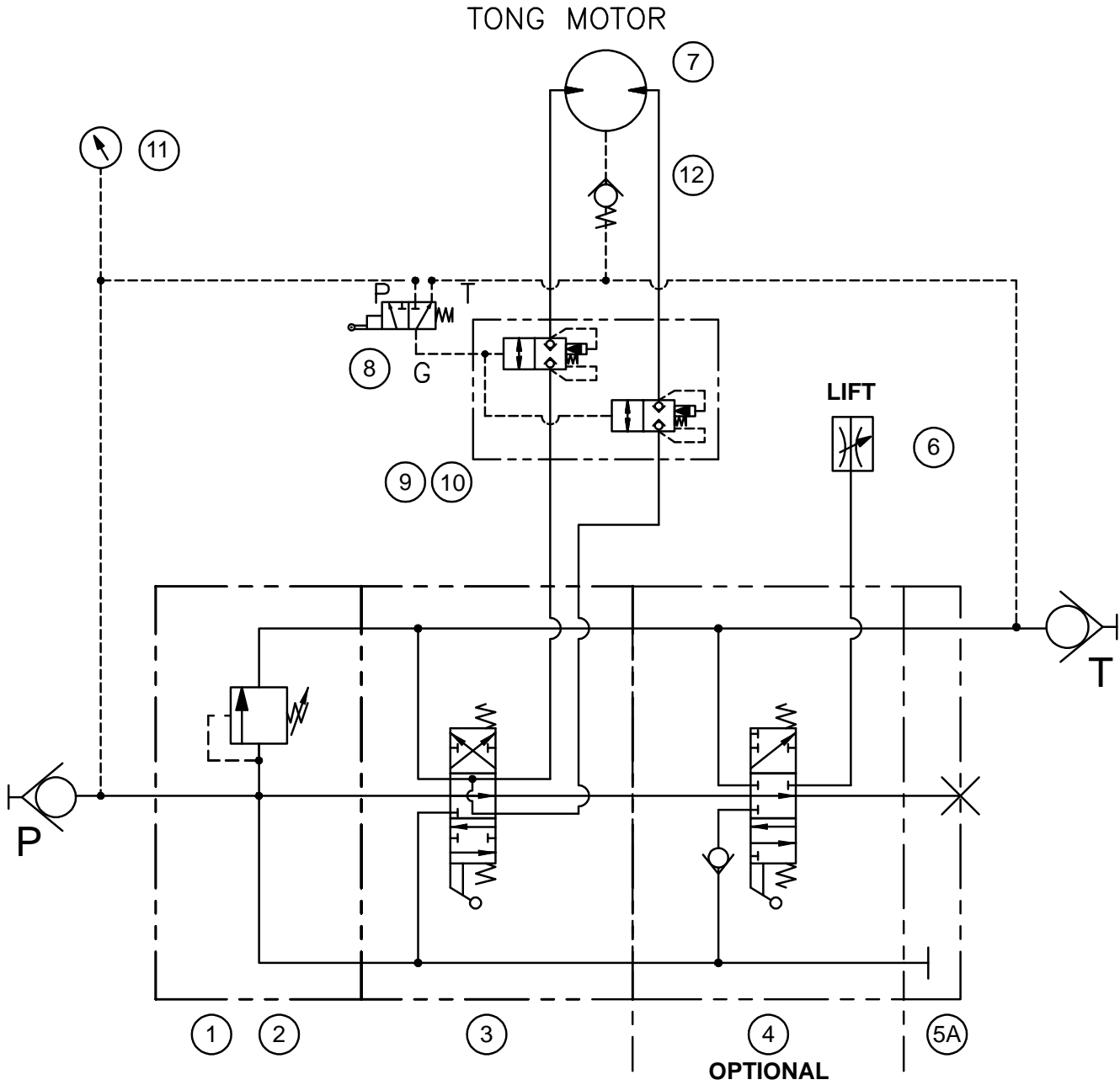


ILLUSTRATION 2.E.3: STANDARD HYDRAULIC SCHEMATIC - CLOSED CENTRE



2.E.1 Hydraulic Schematics (Continued):

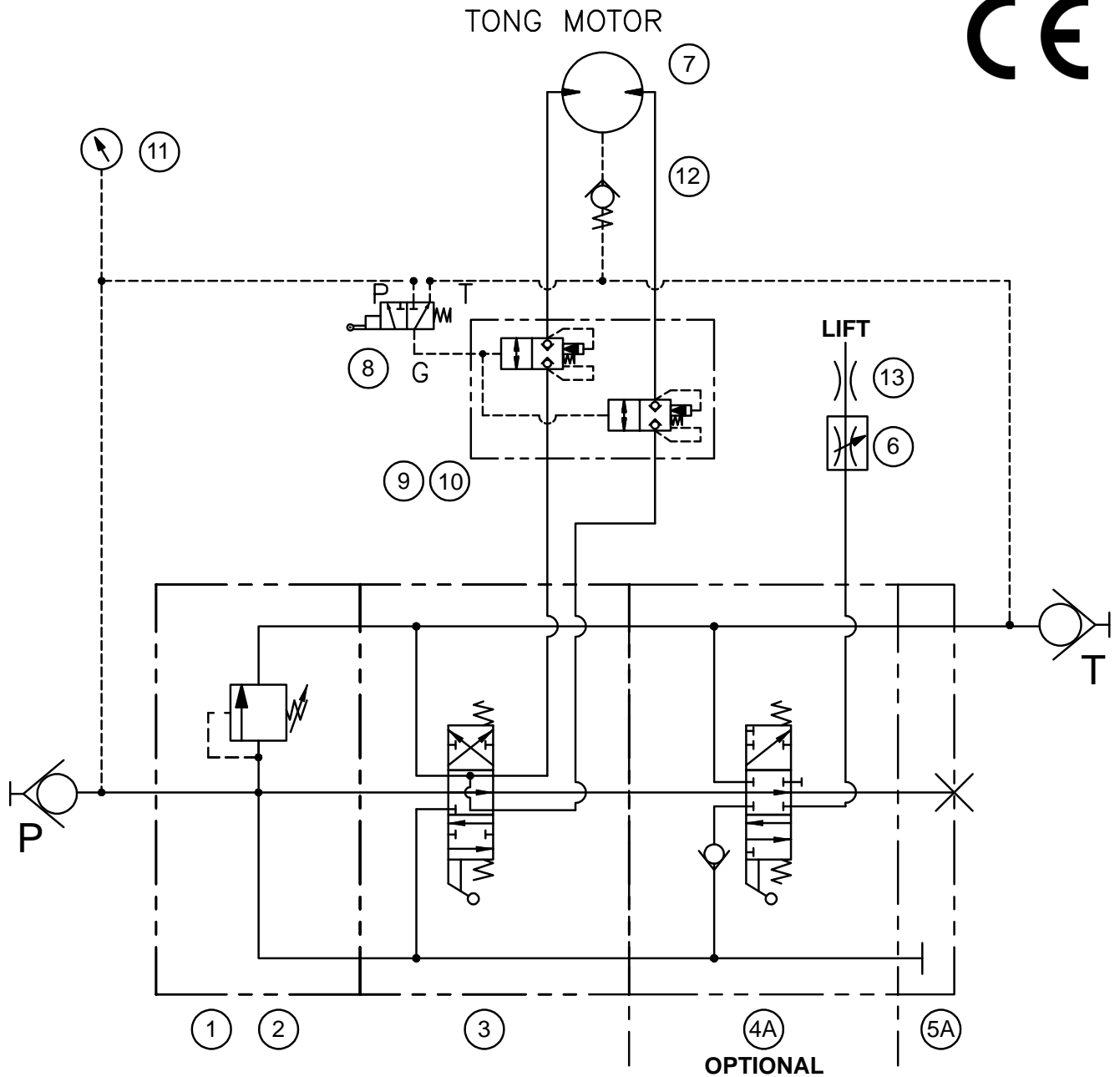
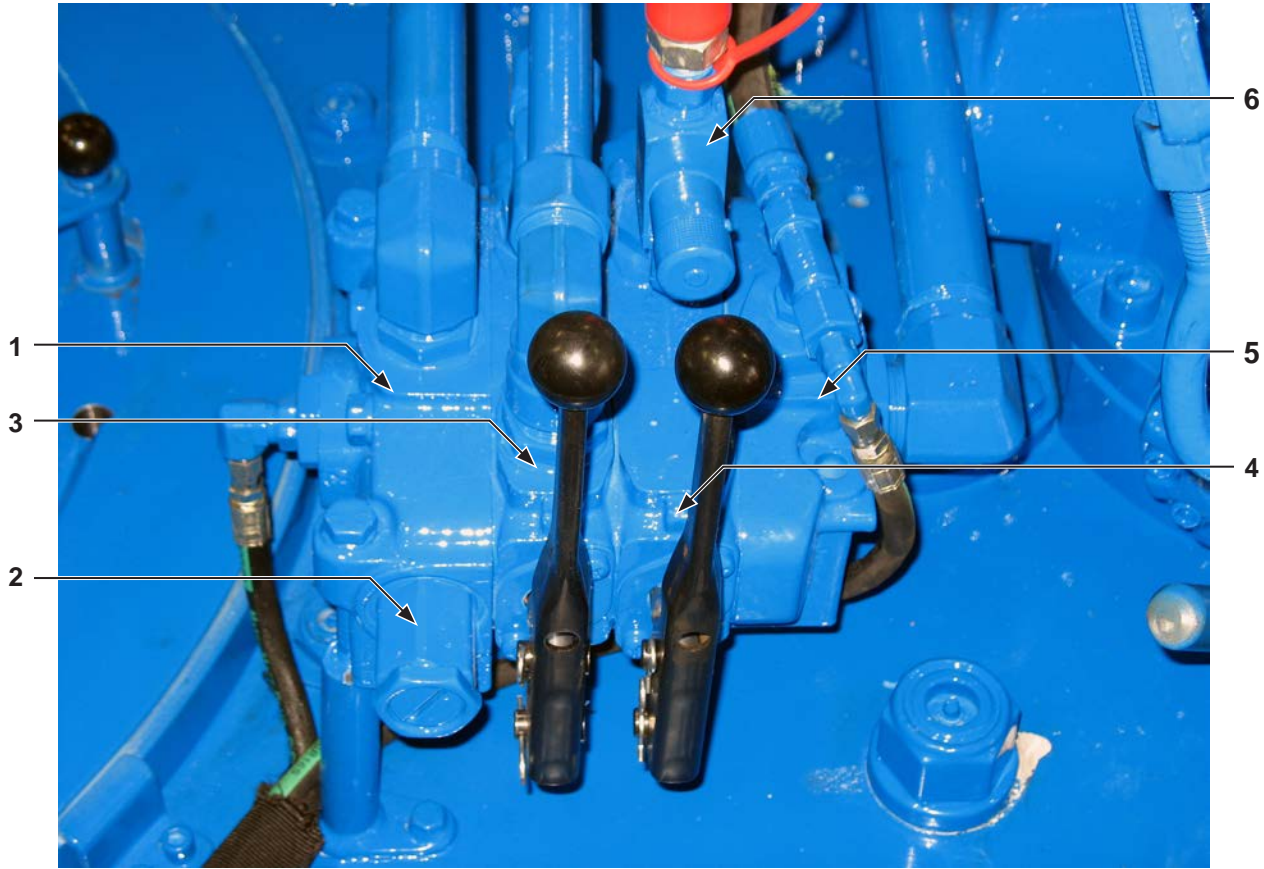
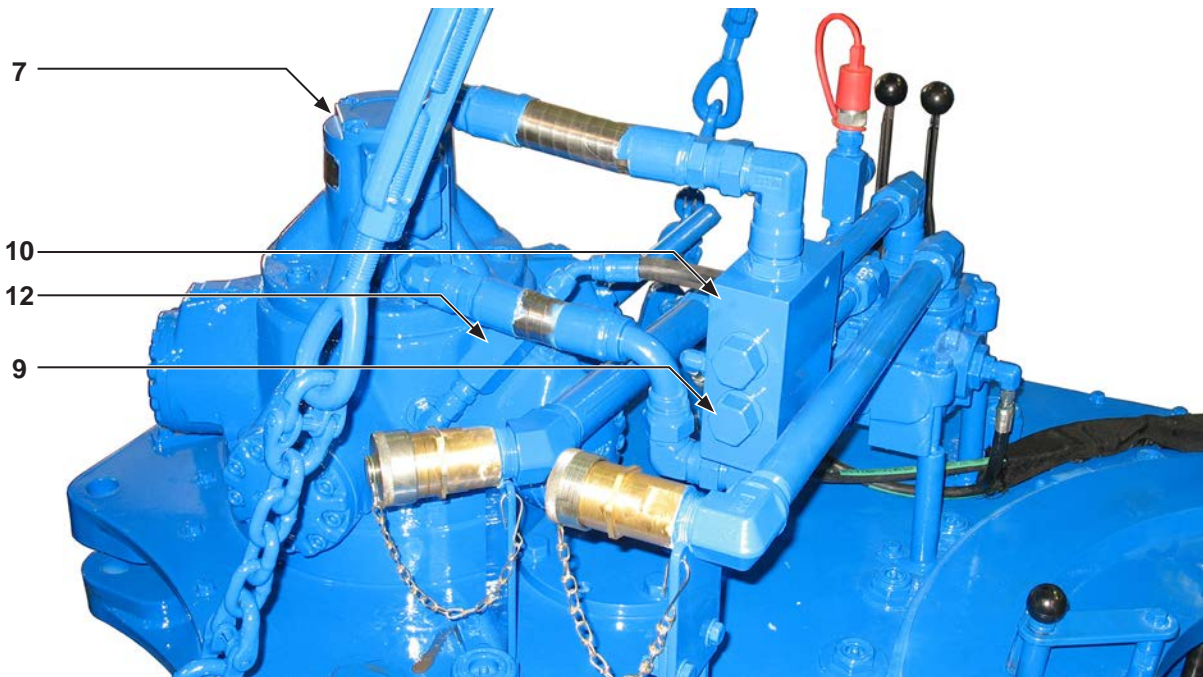


ILLUSTRATION 2.E.4: STANDARD HYDRAULIC SCHEMATIC - CLOSED CENTRE (CE MARKED TONGS)

2.E.2 Hydraulic Component Identification



**ILLUSTRATION 2.E.5: HYDRAULIC COMPONENT IDENTIFICATION 01**



**ILLUSTRATION 2.E.6: HYDRAULIC COMPONENT IDENTIFICATION 02**

2.E.2 Hydraulic Component Identification (Continued):

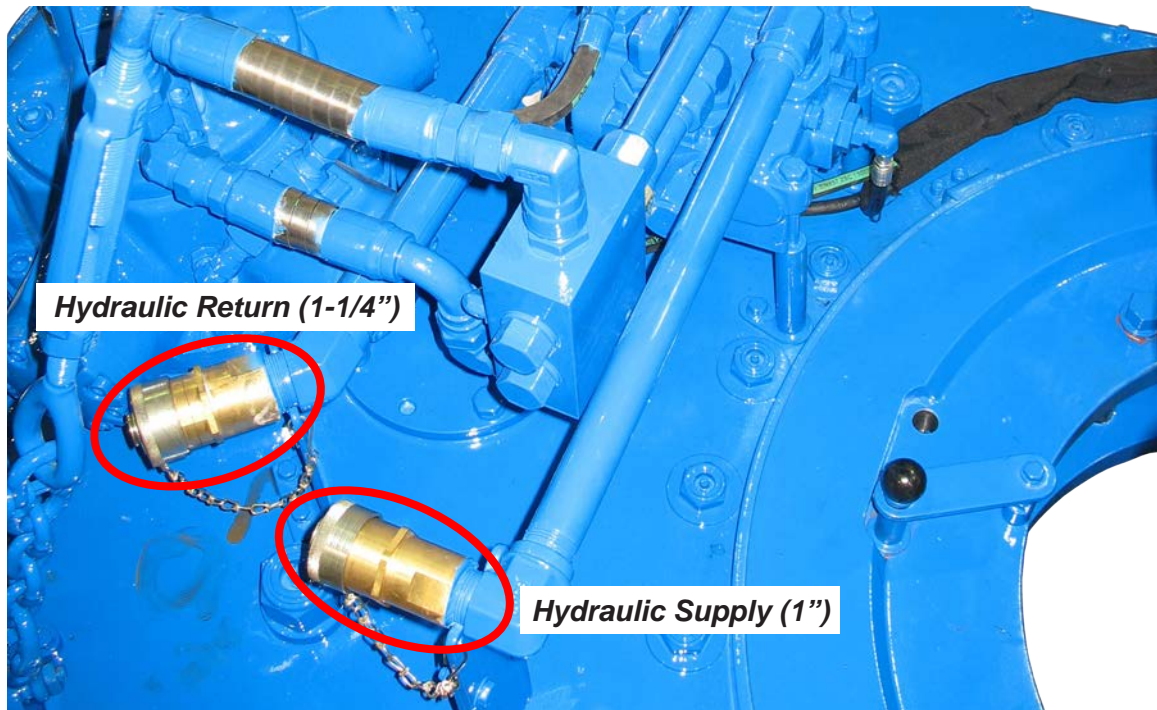


**ILLUSTRATION 2.E.7: HYDRAULIC COMPONENT IDENTIFICATION 03**

2.E.3 Hydraulic Connections

A pair of hydraulic lines - a 1" supply line and a 1-1/4" return line - connect the tong to the power unit (see illustration below). Ancillary devices (hydraulic motors, hydraulic cylinders, etc.) are connected through the valve block.

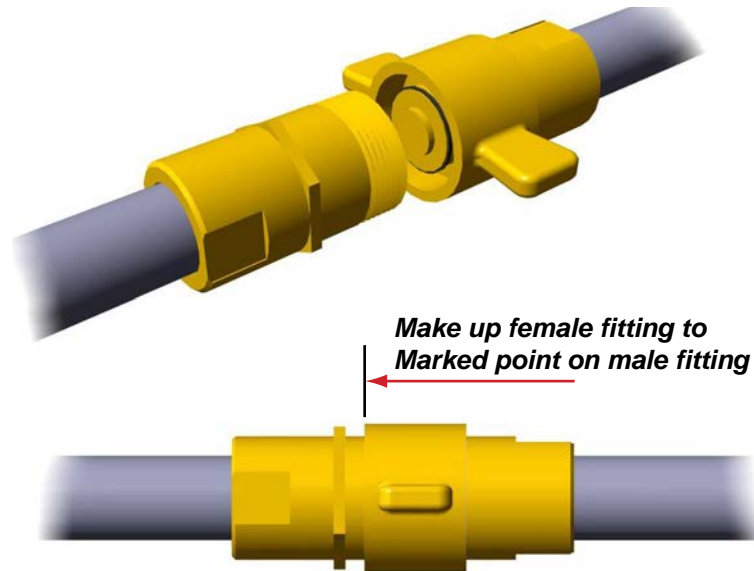
Perform any hydraulic connection when the power unit is not running, or when the hydraulic pump is disengaged. The possibility of error in inter-changing the high pressure supply hose and the low pressure return hose has been eliminated, because the supply side coupling is smaller than the return side.



**ILLUSTRATION 2.E.8: HYDRAULIC CONNECTIONS 01**

These hose couplings are self-sealing, and care should be taken to ensure complete engagement to prevent partial closure of the check valve in the coupling. Ensure that the nut (female) side is completely made up onto the male connector - there is a line on the male fitting that indicates complete make-up. Snug the female fitting right up to the line.

## 2.E.3 Hydraulic Connections (Continued):



**ILLUSTRATION 2.E.9: HYDRAULIC CONNECTIONS 02**



**A CLEARLY IDENTIFIED REMOTE POWER PACK EMERGENCY STOP MUST BE INSTALLED IN THE IMMEDIATE VICINITY OF THE TONG OPERATOR.**

Inspect these connections upon activation of the power unit. Leaking components must be repaired before releasing the tong to the operational environment. Deactivate the power unit and de-pressurize the hydraulic system according to the procedure in Section 3.D. Disconnect the main hydraulic connections and inspect all four connectors (two male, two female) for damage or debris. If the connectors cannot be cleaned or easily repaired, McCoy recommends replacement of the leaking connector. Note that damage to one of the connectors may have caused damage to its mate.

When operating under normal working conditions turn off power unit and depressurize hydraulic system before disconnecting the main hydraulic lines (see Section 3.D for hydraulic system depressurization)-. McCoy recommends placing protective caps over the exposed connectors to protect them from water and impact damage.



**ALWAYS TURN OFF HYDRAULIC POWER AND DEPRESSURIZE HYDRAULIC SYSTEM BEFORE DISCONNECTING MAIN HYDRAULIC LINES.**




2.F TONG JAW AVAILABILITY & INSTALLATION

2.F.1 Jaw Availability

The following table lists all jaw die kits that are available as standard stocked sizes for this model of tong. McCoy Global offers a good selection of standard jaw sizes. However, please note that McCoy can custom-engineer and manufacture any size of jaw within the range of the tong. Jaw systems are available to allow use of die inserts intended for specialized applications. Call our sales office for information on jaw and die systems designed for higher or lower grip, or non-marking applications.

The table lists standard contoured, flat and wraparound die inserts that are available as spare parts. However, a wide variety of diamond-tooth, GRITFACE®, and wrap-around fine-tooth dies are available for specialized applications. Please refer to our website for complete information:

<http://www.mccoysglobal.com/dies-inserts>



**USE OF ALUMINUM DIES IS FORBIDDEN ON CE-MARKED EQUIPMENT**

Description	Part Number
7" Jaw Die Kit	1037-JDK-543
7-5/8" Jaw Die Kit	1037-JDK-539
8-5/8" Jaw Die Kit	1037-JDK-540
9-5/8" Jaw Die Kit	1037-JDK-545
10-3/4" Jaw Die Kit	1037-JDK-550
11-3/4" Jaw Die Kit	1037-JDK-555
13-3/8" Jaw Die Kit	1037-JDK-558
13-5/8" Jaw Die Kit	1037-JDK-560
14-3/8" Jaw Die Kit	1037-JDK-564
16" Jaw Die Kit	1037-JDK-565
18-5/8" Jaw Die Kit <sup>(1)</sup>	1037-JDK-570
20" Jaw Die Kit <sup>(1)</sup>	1037-JDK-575
<sup>(1)</sup> Uses 3.875" replacement die	13-0008-314-0
All other kits use 5" replacement die	13-0008-500-0

2.F.2 Jaw/Jaw Die Replacement

Removal of the dies are simple, requiring removal of only the top retainer. However, the tong jaws will often require removal to change jaw size or remove jaw die inserts that are stuck in the dovetail slots. Disconnect or disable hydraulic power supply before proceeding.



**DO NOT ACCESS ROTATING COMPONENTS UNLESS HYDRAULIC POWER SUPPLY HAS BEEN DEACTIVATED OR ISOLATED.**

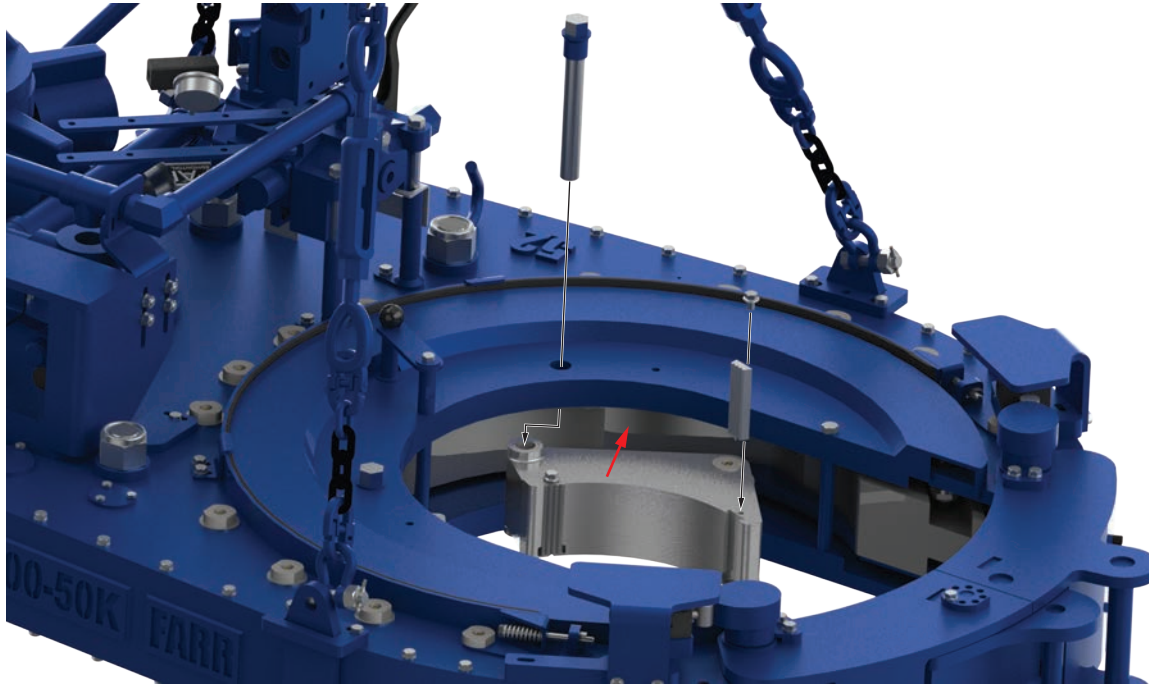
Remove the flanged retaining bolts to remove the dies - jaw dies may require light tapping with a hammer to free them from their slots. Reverse this procedure to install new jaw dies.

If required, remove the tong jaws. Support tong jaw assembly being removed. Remove the jaw pivot bolt, and slide the jaw towards the centre of the rotary assembly to free the jaw from the cage plates.

Note that if space allows, the entire jaw assembly does not need to be removed to replace the jaw dies (see Illustration 2.F.1)



**JAWS MAY PRODUCE METAL SLIVERS. WEAR STURDY GLOVES WHEN REMOVING AND INSTALLING JAW DIE KITS.**

**2.F.2 Jaw/Jaw Die Replacement (Continued):****ILLUSTRATION 2.F.1: JAW REMOVAL**

Once the jaw has been removed the jaw dies may be replaced by removing the keeper screw above the die, and tap the die from jaw using a hammer. Replace the die, tapping it into place if necessary, and replace the keeper screws.

**2.G TONG RIG-UP & LEVELING****2.G.1 Suspension & Restraint**

Suspend the tong from a location as near to the centre of the drill rotary as possible, and from a location high enough on the mast to ensure easy handling. The lower the point from which the tong is suspended, the more effort will be required to move the tong to and from the connection point.

The suspension line may be extended over a pulley and balanced by a counterweight equal to the weight of the tong, or simply tied off in the derrick to form a dead line. When using a dead line arrangement it is necessary to use a spring hanger supplied by McCoy Global (see specification page for recommended spring hanger). This spring hanger compensates for the downward movement of the casing as the thread is made-up, and imparts additional force to the suspension cable:

- a “single spring” hanger typically applies 420 lbs. (191 kg.) to the suspension line for every inch of thread made up
- a “double spring” hanger typically applies 840 lbs. (382 kg.) to the suspension line for every inch of thread made up

If you do not know which specific spring hanger is in use, check the specification page in this manual for information on the recommended spring hanger for this application. McCoy Global will not guarantee or specify spring hangers other than what has been supplied by McCoy.

Many applications use a lift cylinder for adjusting the height of the tong. Ensure the weight of the lift cylinder is known if it has not been included in the total weight of the tong.

All forces upon the suspension line must be considered when calculating necessary strength of the suspension line. The weight of the tong, the weight of the lift cylinder, the weight of the spring hanger, and the force imparted on the suspension line by the spring hanger must all be added together in order to arrive at the total force supported by the suspension line. Select your suspension line based upon the total force and the margins of safety dictated by the policies of your company and by established engineering practices. Ultimately, calculating the force on the suspension line and selection of the suspension line is the complete responsibility of the customer.

McCoy Global recommends using dual backup (snub) lines of sufficient strength to withstand the force imparted by the maximum rated torque of the tong in use. Calculate the force on the snub lines by dividing the maximum torque of the tong by the tong’s torque arm (expressed in feet). For example, an 50,000 lbs.-ft. tong with a 52 inch (4.333 ft.) torque arm will generate 11,540 lbs. of force against the snub line. Select your snub lines based upon the total force and the margins of safety dictated by the policies of your company and by established engineering practices. Ultimately, calculating the force on the snub line and selection of the snub line is the complete responsibility of the customer.

**2.G.1 Suspension & Restraint (Continued):**

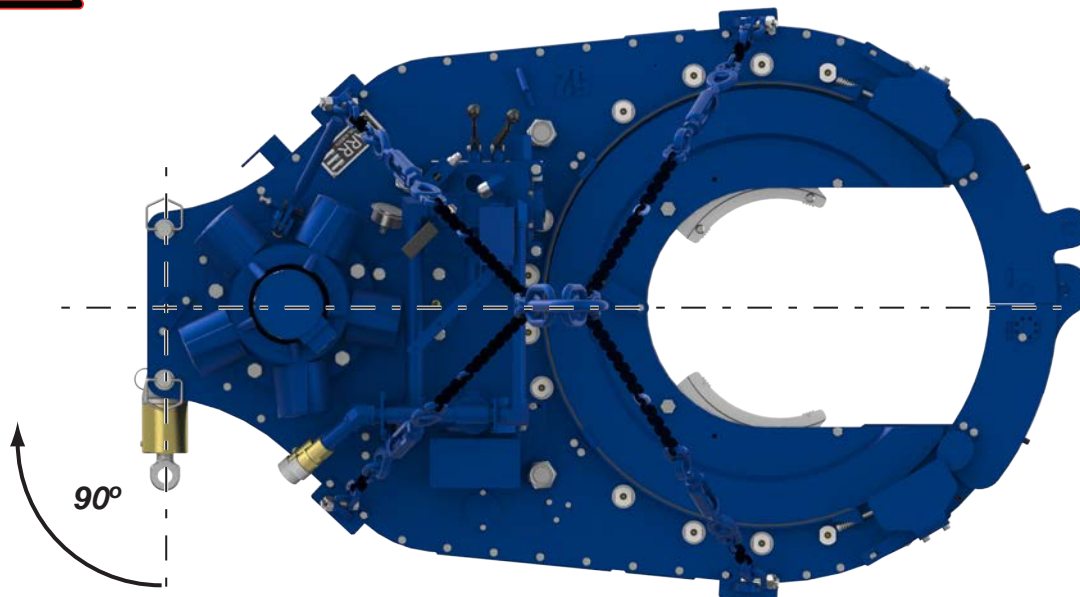
Snub lines must be securely connected to the rear of the tong, and tied off to a suitable anchor. One snub line must be secured to the load cell, which is then secured to the rear of the tong. The side of the tong the load cell connects to is dependant upon whether make-up or break-out activities are underway. To ensure accurate torque measurement, the torque measurement line must be connected perpendicular to the lengthwise axis of the tong, and perpendicular to the hang line (see illustrations 2.G.1 and 2.G.2). Connect the second snub line on the opposite side of the load cell, perpendicular to the lengthwise axis of the tong and perpendicular to the vertical.



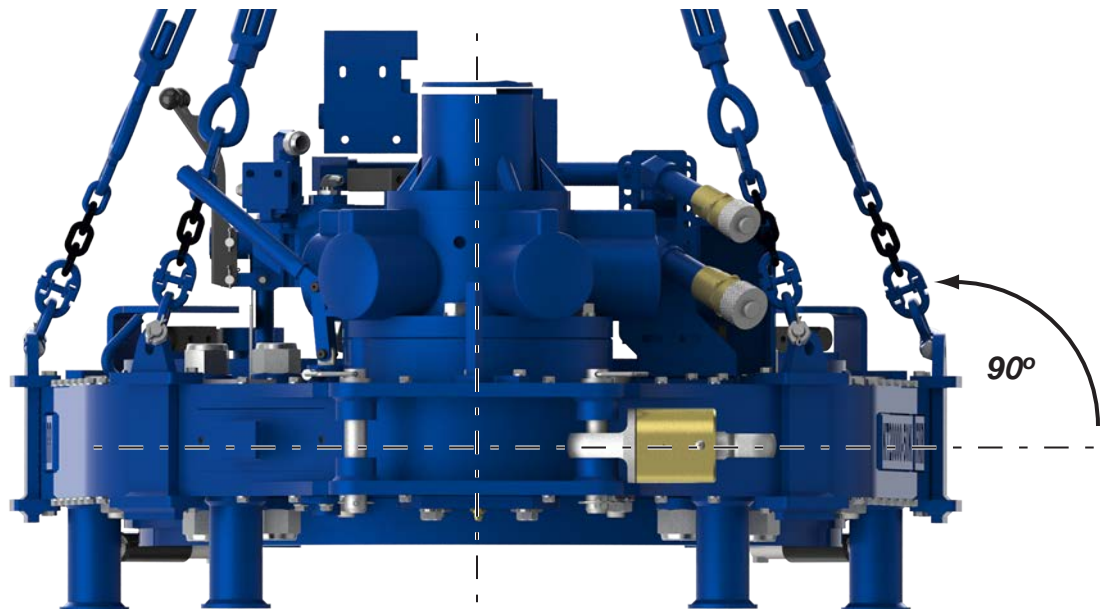
**MCCOY GLOBAL ACCEPTS NO RESPONSIBILITY FOR DESIGNING AND SELECTING AN ADEQUATE SUSPENSION AND RESTRAINT SYSTEM FOR YOUR DRILLING EQUIPMENT**



**ALL SELECTED FASTENERS, SHACKLES, CLAMPS, ETC. USED FOR CONSTRUCTING THE SUSPENSION AND SNUB LINES MUST BE RATED FOR THE CALCULATED FORCES.**



**ILLUSTRATION 2.G.1: TONG SUSPENSION RELATIVE TO AXIAL CENTRE**



**ILLUSTRATION 2.G.2: TONG SUSPENSION RELATIVE TO VERTICAL CENTRE**

**2.G.2 Tong Leveling**

The tong must be leveled side-to-side and front-to-rear before placing into service. The following guidelines will assist you when leveling your tong.



**FAILURE TO PROPERLY LEVEL TONG MAY RESULT IN JAW SLIPPAGE OR FAILURE OF JAW COMPONENTS**



**ONLY USE THE MASTER LINK TO SUSPEND THE TONG ASSEMBLY. THE CHAIN SLING IS DESIGNED TO BE USED FOR VERTICAL LIFTING ONLY.**

1. Support the tong by the chain sling. Preset the positions of all four chains by rotating the turnbuckles on each chain hanger until the eye bolts are about half-way engaged in the turnbuckle. The turnbuckles can often be turned by hand; if this is not the case, use an adjustable wrench across the flats on the turnbuckle to turn it. Rotating the turnbuckles in one direction will cause the two eye bolts to extend away from the centre of the turnbuckle, while rotating them in the other direction will cause the eye bolts to retract toward the centre of the turnbuckle.
2. Place a level axially (side to side) across the tong, ensuring that it is parallel with the surface of the tong. Equally rotate the two turnbuckles on one or the other side of the tong until the level indicates the tong is parallel - for instance, if you decide to adjust the left side hangers to adjust the axial leveling, adjust the left side front and rear chains the same amount. If there seems to be a large adjustment to make, split the adjustment between the two sides - make half the adjustment using the two chains on one side, and the remaining adjustment using the two chains on the other side. If all four chains were pre-set, there should not be a large adjustment to make.
3. Place a level lengthwise (front to back) along the tong, ensuring that it is parallel with the surface of the tong. If the tong needs to be leveled front to rear, adjust both chains equally - either both rear chains or both front chains.

The leveling process may have to be repeated in order to optimize the adjustment of the hanger chains and ensure the tong is level.



**ILLUSTRATION 2.G.3: LEVELING TONG USING TURNBUCKLES**



## 2.H TONG OPERATION

### 2.H.1 Operator Training

Many companies set qualification standards that must be met before equipment may be operated without supervision. McCoy Drilling & Completions recommends operator training, which typically consists of operation of the equipment under the supervision of a trained equipment operator until a satisfactory level of competence is achieved. Typical operator training should include:

- Introduction to and general description of equipment
- Technical specifications and performance data
- Operating instructions
- Control systems and interlocks
- Operating hazards
- Checks and inspections

### 2.H.2 Operator Safety

McCoy recommends that a hazard assessment of the work area be performed by a designated safety representative before commencing operations. A designated safety representative is responsible for verifying that all operators have adequate equipment and safety training.

The safety door system is the primary device protecting the tong operator and nearby personnel from the rotary gear. Confirm the correct operation of the safety door before every job. Never disable the safety door device.



Inspect anti-tamper devices on safety door components before beginning job. Equipment showing signs of tampering on any safety system must be immediately removed from service and tested. Anti-tamper devices must be restored before allowing equipment to be released to an operating environment.

The area surrounding the tong operating area must be clutter-free and free from tripping hazards, or protruding objects that may snag hydraulic hoses on the tong, backup, lift cylinder, or torque measurement system. Operating surface or drill floor must be kept free of slipping hazards like grease, oil, water, etc.

Adequate lighting of the work area is required. All warnings, labels, gauges, and signs must be clearly visible

The components of the tong commonly manipulated or requiring control input are painted green, and are safe for continuous handling. Areas painted yellow are designated as hazardous areas, and contact with those areas must be avoided during operation. Always wear all personal protective equipment (PPE) specified by your company's HSE policy, and follow all of your company's safety guidelines.



### **ALWAYS WEAR APPROVED PERSONAL PROTECTIVE EQUIPMENT (PPE) WHEN OPERATING HYDRAULICALLY-POWERED EQUIPMENT.**

Ensure hydraulic power is deactivated and tong hydraulics are de-pressurized before disconnecting the main hydraulic lines. McCoy recommends depressurizing the tong hydraulic system before connecting or disconnecting quick-connect fittings.



### **DEPRESSURIZE EQUIPMENT BEFORE DISCONNECTING MAIN HYDRAULIC LINES.**

### 2.H.3 Valve Operation

4-way proportional valves control operation of hydraulic devices on the tong assembly such as hydraulic motors and cylinders. When any one valve is "centered" or in the detent position, there is no hydraulic output from the valve. When the valve is pushed forward there is an effect, and when the valve is pulled back, there is an opposite effect. These valves feature proportional control, which means that further extension of the valve handle (thereby further opening the valve orifice) results in proportionally higher hydraulic output to the controlled device.

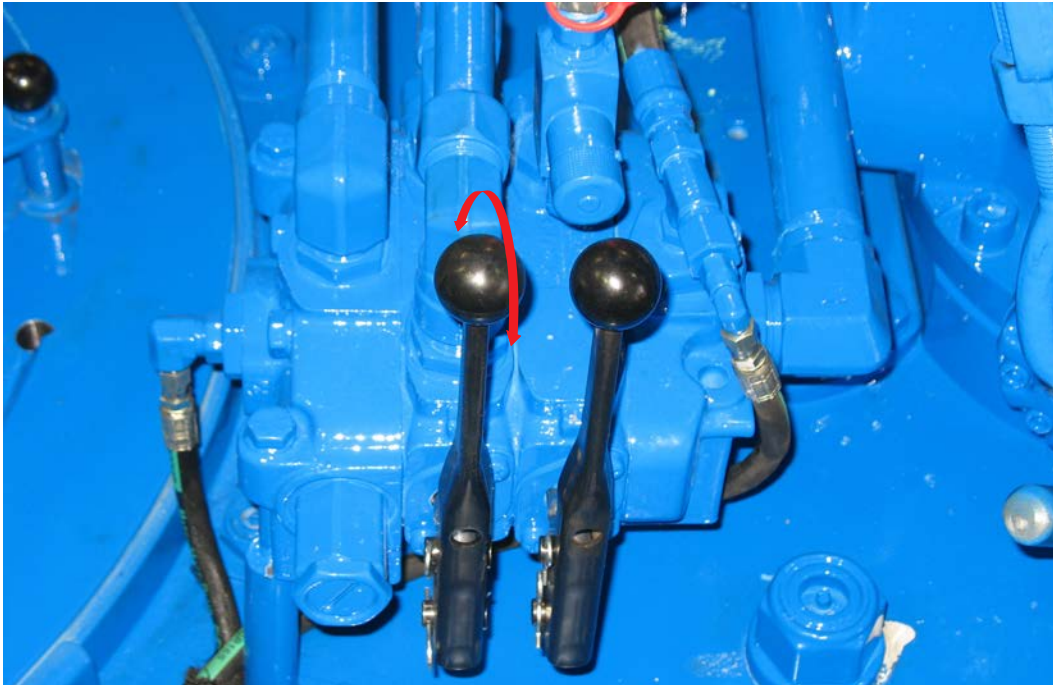
The following illustrations demonstrate the type and effect of the hydraulic valves with which this tong is may be equipped.

#### TONG MOTOR

This is a proportional valve. Pushing the valve handle forward will cause the tong motor to rotate in a clockwise direction (as seen from the top of the tong). This is the desired direction of rotation for making up a joint. Pulling the valve handle in the opposite direction results in counter-clockwise rotation, which is the desired direction of rotation for breaking out a joint. Releasing the valve handle will cause the tong to immediately stop rotation.

**2.H.3 Valve Operation (Continued):****TONG MOTOR**

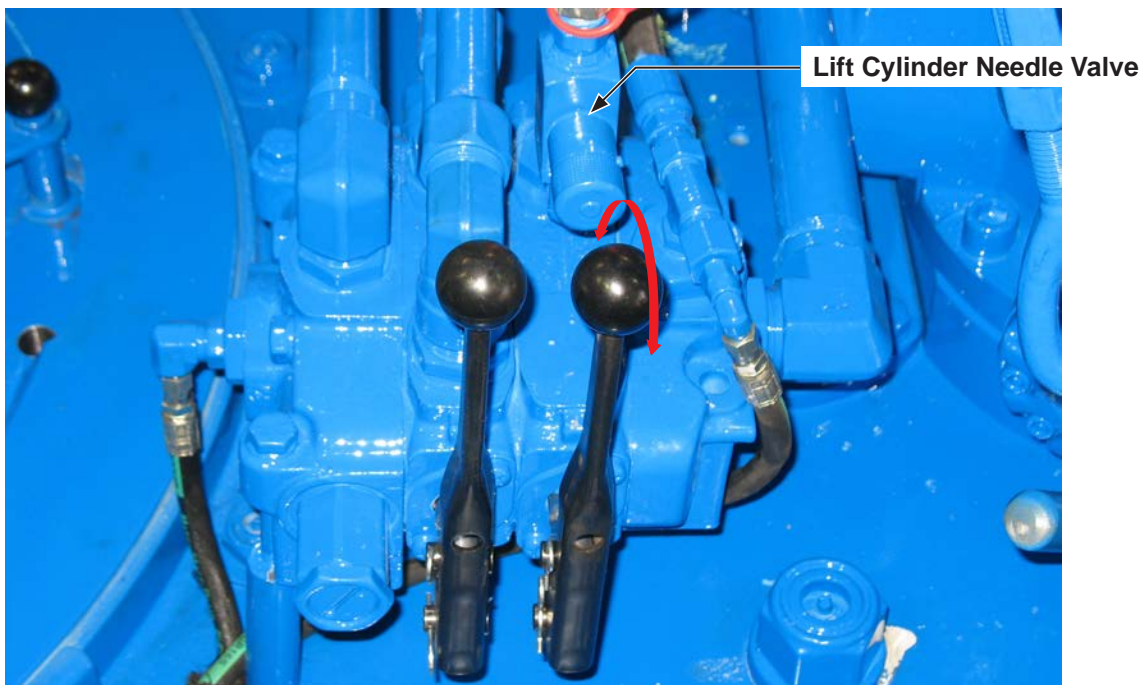
This is a proportional valve. Pushing the valve handle forward will cause the tong motor to rotate in a clockwise direction (as seen from the top of the tong). This is the desired direction of rotation for making up a joint. Pulling the valve handle in the opposite direction results in counter-clockwise rotation, which is the desired direction of rotation for breaking out a joint. Releasing the valve handle will cause the tong to immediately stop rotation.



**ILLUSTRATION 2.H.1: TONG MOTOR CONTROL VALVE**

**LIFT CYLINDER CONTROL VALVE**

This is a direct-acting valve. Pulling out on the valve handle will cause the lift cylinder to lift the tong vertically. Pushing in on the valve handle will cause the lift cylinder to lower the tong. Releasing the valve handle will immediately stop the lifting or lowering action.



**ILLUSTRATION 2.H.2: TONG LIFT CYLINDER CONTROL VALVES**

## 2.H.3 Valve Operation (Continued):



Pushing on the lift cylinder control valve handle (toward the center of the tong) will cause the equipment to lift, while pulling on the lift cylinder control valve handle (toward the operator) will cause the equipment to lower. This valve handle action applies to all CE-marked tongs and is regardless of control valve bank orientation.

## LIFT CYLINDER NEEDLE VALVE (See illustration 2.H.2)

This needle valve regulates hydraulic fluid flow to the lift cylinder. Closing the needle valve (rotating the knob clockwise) will increasingly restrict the flow rate of the fluid, resulting in slower actuation of the cylinder in both directions (lifting & lowering).

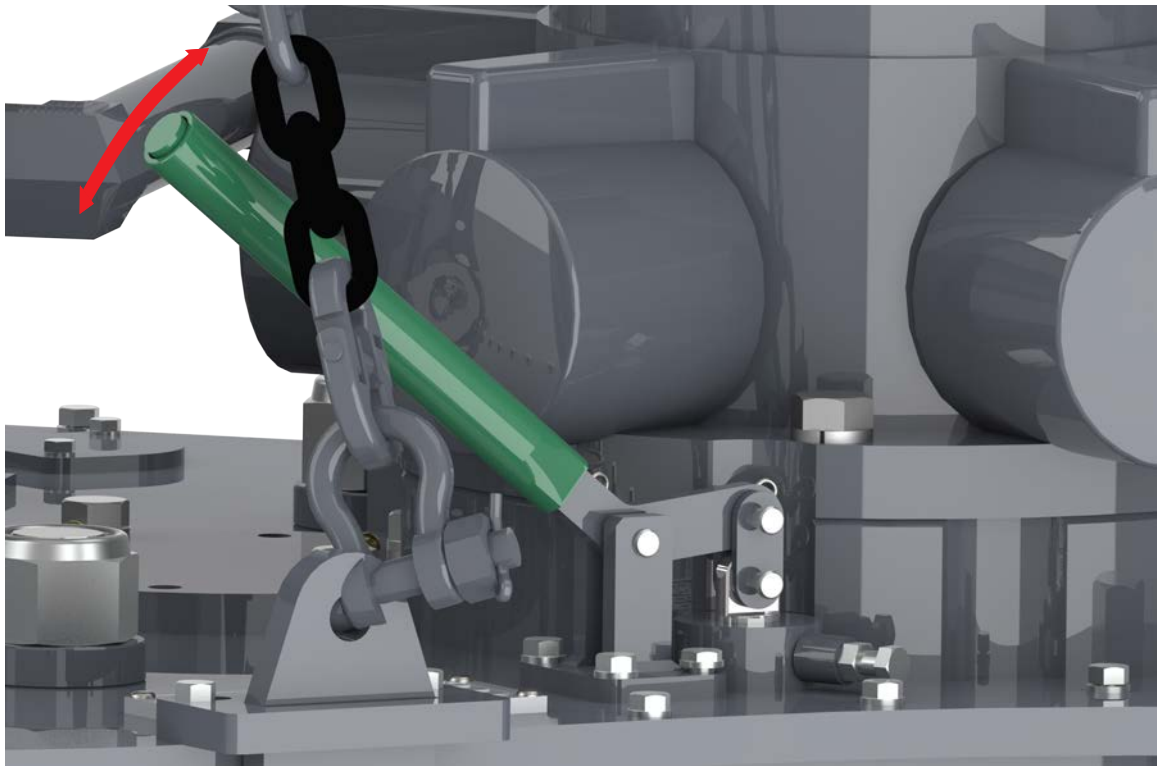
## 2.H.4 Shifting Gears

The shifting shaft has three “detent” positions identifying the low speed/high torque position, the “neutral” or free-spinning position, and the high speed/low torque position. The detent strength may be adjusted by releasing the locknut on the detent tube and increasing or relaxing pressure on the detent spring. Ensure the locknut is tightened once the desired detent pressure has been set.

To shift to the high-speed gear, move the shifting handle DOWN from neutral position. To shift to the low-speed gear, move the shifting handle UP through the neutral detent to its HIGHEST position. Note that the high clutch gear or the low clutch gear may not be exactly aligned when shifting, so the operator may need to “bump” the motor control handle slightly to turn the main clutch gear shaft and shifting collar into alignment. The most effective way of achieving this is to apply a small amount of pressure on to the gear shift lever in the direction you want to shift the tong, ensuring the shifting collar will “catch” when the main clutch gear aligns with either the high or low clutch gear.



**DO NOT SHIFT TONG WHILE ROTATING THE MOTOR AND CAGE PLATE. CATASTROPHIC GEAR TRAIN FAILURE MAY RESULT.**



**ILLUSTRATION 2.H.3: SHIFTING GEARS**

### 2.H.5 Pre-Operational Checks

McCoy recommends that the following pre-operating tests be performed prior to releasing the tong assembly to a operational environment:

1. Connect the tong to a hydraulic power source in a controlled environment. Ensure the power unit's operating parameters are within the specifications as identified on Pg. 1.3. Ensure the hydraulic connections from the power unit are properly and securely made up (see Section 2.E.3). Do not neglect to connect the motor drain line.
2. Start the power unit as specified by the power unit operator's manual. Open the Bypass Valve on the hydraulic system, and inspect all pressure and return line hose connections to ensure correct and secure installation. A restriction in the pressure supply hose will result in high pressure within the power unit hydraulic system, which will activate the hydraulic governor and increase the engine speed to as high as maximum RPM. A restriction in the return line will result in high pressure within the power unit and the tong hydraulic system, causing engine speeds as high as maximum RPM, and possible failure of the motor seal.



#### **A CLEARLY IDENTIFIED REMOTE POWER PACK EMERGENCY STOP MUST BE INSTALLED IN THE IMMEDIATE VICINITY OF THE TONG OPERATOR.**

3. Allow hydraulic system to warm by circulating fluid for about 10 minutes, then slowly close the bypass valve to allow hydraulic fluid to circulate through the hoses and tong. Ensure circulating pressure does not exceed 200 psi.
4. Inspect all hydraulic hoses and connections on the tong. Immediately correct any hydraulic fluid leaks.
5. Inspect all gauges. Replace leaking or cracked gauges, or any gauge not registering a reading.
6. Confirm that all load-bearing pins and R-clip retainers are installed and in good condition (rigid sling pins, lift cylinder pins).
7. Confirm all hydraulic hoses (with the exception of the supply & return to the backup) are securely fastened to the tong, and are not in contact with the cage plate or creating a snagging hazard.
8. Ensure the tong door is securely closed before rotating tong.



#### **DOOR MUST BE CLOSED AND SECURELY LATCHED BEFORE TONG ROTATION IN ORDER TO ASSURE THE SAFETY OF OPERATING PERSONNEL.**

9. Shift the tong to low gear (see subsection 2.H.4) and rotate the tong slowly forward for approximately a minute. Stop the tong and then reverse the rotation direction for approximately another minute. Stop the tong, shift to high gear, and operate in high gear for approximately another minute. Stop the tong and rotate in the opposite direction in high gear for approximately another minute. If at any time abnormal operation is suspected (surging, grinding, squealing, or other noises deemed to be unusual, or failure to operate) discontinue operation of the tong and contact McCoy Drilling & Completions immediately.
10. Re-inspect all hydraulic lines and connections on the tong, and correct all leaks.
11. The tong door sensor/shutdown (safety door) system is the prime protective measure separating the operator from the rotary gear, and must be in working condition when operating tong. The safety door system is an integral safety feature that must not be bypassed or disabled. Operating the power tong with a malfunctioning or non-operating door sensor/shutdown system exposes the operator and rig personnel to potentially fatal injury. do not operate tong with a malfunctioning or non-operating door sensor/shutdown system. Routinely testing the sensor/shutdown system operation before mobilizing and at each shift change ensures protection of drill floor personnel.

A rotating tong potentially stores a large amount of kinetic energy in the gear train. Testing the sensor/shutdown system by suddenly opening the tong door to stop rotation will generate a shock load that could result in catastrophic equipment failure not covered by the manufacturer's warranty, and may present a hazard to personnel on the drill floor. The following procedure outlines the correct, safe procedure for testing the door sensor/tong shutdown system on a McCoy power tong.

Using the correct testing procedure ensures the sensor/shutdown system is fully functional without exposing the equipment to a shock load or personnel to a potential hazard. The tests also verify that the shut down valve is positively sealing and rules out the possibility that contaminated hydraulic fluid or erosion is preventing the valve from completely shutting off the motor's supply of hydraulic fluid.

- a. Shift the tong to low gear (see Section 2.H.3).
- b. Stop all tong rotation.
- c. Open the tong door.
- d. Gradually attempt to turn the tong using the rotation control handle. Continue to gradually move the handle until the valve is fully stroked, and hold for 30 seconds. Verify the ring gear does not rotate while the rotation control is engaged. PROCEDURAL NOTE: a very small amount of ring gear movement is acceptable as the cartridge valve seats to stop rotation.

**2.H.5 Pre-Operational Checks (Continued):**

11. Tong door sensor/shutdown (safety door) system testing (continued):
  - e. Release the valve handle and allow the valve to go to the neutral position. Gradually attempt to turn the tong in the opposite direction until the valve is fully stroked, and hold the handle in the fully stroked position for 30 seconds. Verify the ring gear does not rotate while the rotation control is engaged. PROCEDURAL NOTE: a very small amount of ring gear movement is acceptable as the cartridge valve seats to stop rotation.
  - f. Ensure tong door is fully opened. Move the rotation control handle to approximately 50% of its full stroke. Have an assistant slowly close the tong door while continuing to hold the directional control valve at 50%. Rotation should commence only once tong door is fully closed.

If the safety door does not operate as designed further troubleshooting of the safety door system may be required. See Section 4.D for safety door troubleshooting instructions.

The safety door switch is protected from impact by a sturdy metal guard, painted yellow. This guard must be inspected before each use of the tong. All components of the guard must be in place, and all fasteners securing the guard must be intact and tight. Ensure wire ties (where applicable) on safety door components are present and secure, and do not show signs of tampering.



**DO NOT OPERATE TONG WITH A MALFUNCTIONING OR NON-OPERATING SAFETY DOOR SYSTEM.**

**2.H.6 General Operational Comments**

1. Position rotary gear in contact with both idler gears when breaking out joints or collars where high torques are required.
2. When making-up integral (shouldered) joints, it is essential to make up the last turn of the threads in low gear. This reduces the tendency of an instant stop or a sudden increase in torque, which induces extremely high stresses on the gear train.
3. DO NOT employ the “snap break” method of breaking-out joints when pulling a string. The extremely high stress placed on the gear train frequently causes gear breakage.



**THE “SNAP-BREAK” METHOD OF BREAKING CONNECTIONS IS HAZARDOUS TO RIG PERSONNEL AND EQUIPMENT**



## 2.1 MAKING AND BREAKING CONNECTIONS



**THESE OPERATING PROCEDURES ASSUME THE USER HAS PROPERLY SET UP AND PREPARED THE EQUIPMENT FOR OPERATION AS PER SECTIONS 2D, 2E, AND 2F OF THIS MANUAL.**

Set up and prepare your equipment for operation as per Section 2 of this manual Refer to the following sections:

- 2.D - Lift Cylinder Installation
- 2.E.3 - Hydraulic Connections
- 2.F - Tong Jaw Installation
- 2.G.1 - Tong Rig-up and Leveling (Suspension)
- 2.G.2 - Tong Rig-up and Leveling (Leveling)

Your tong and backup assembly should be properly suspended, connected to a hydraulic power source, and ready to make or break connections at this point.

## 2.1.1 Making A Connection

1. Ensure hydraulic power supply to the tong is energized. The master link on the chain sling must be used to suspend the tong. Do not suspend the tong from any other point.



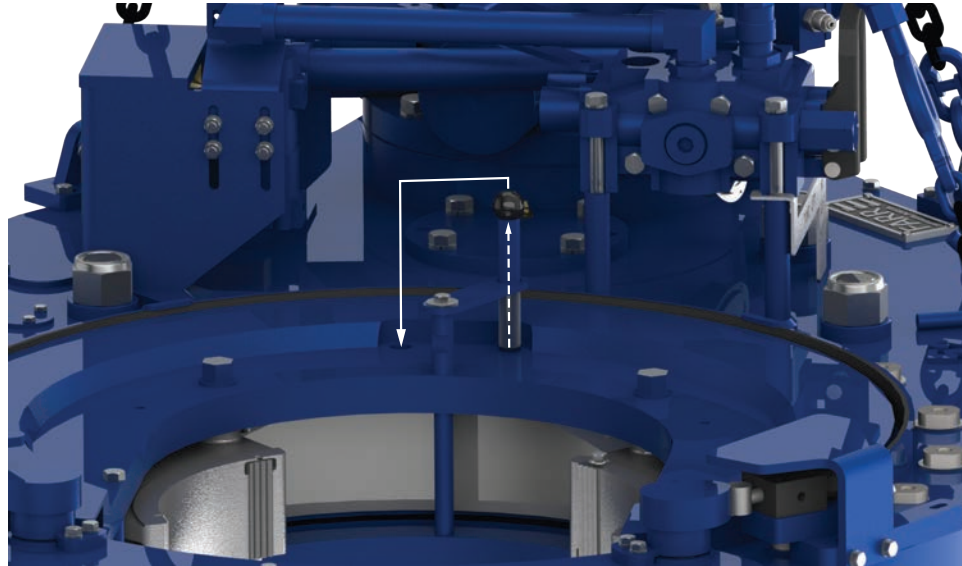
**ILLUSTRATION 2.1.1: MASTER LIFTING LINK**



**THE MASTER LINK MUST BE USED TO SUSPEND THE TONG ASSEMBLY**

2. Ensure the backing pin is in the “makeup” position. From the front of the tong, the backing pin correctly configured for makeup will be in the 10 o’clock position (see Illustration 2.1.2 next page). If it is not, simply lift up and place in the correct position. The cage plate opening must be aligned with the door opening when setting the backing pin position.

## 2.1.1 Making A Connection (Continued):



**ILLUSTRATION 2.1.2: SETTING BACKING PIN TO "MAKE-UP" POSITION**

3. Ensure the load cell and snub line(s) are properly configured for making up connections. A "snub line" is a length of wire rope that connects the rear of the tong body to a sturdy anchor on the drill floor (see Section 2.G.1). The snub line prevents the tong body from spinning in the opposite direction of the cage plate when torque begins to build in the joint. McCoy Global recommends using two snub lines when running the equipment to eliminate uncontrolled movement in either rotational direction. The snub line(s) must be rated for the applied torque plus whatever safety margins stated by your own operating policies. The snub line connection point on the drill floor must be sturdy enough to absorb all applied forces when making up the joints. When making up joints the load cell must be connected to the driller's side of the tong, which is the left side of the tong as seen from the rear. For accurate torque measurement the snub line between the tong body and the anchor must be perpendicular to the vertical, and perpendicular to the centre-line of the tong.
4. Actuate the lift cylinder control valve to lift the assembly from the drill floor. Pulling on the valve handle toward the operator will retract the lift cylinder to lift the assembly (see Illustration 2.1.3 next page). Note that rig personnel are required to stabilize the tong and backup as it is being lifted so it does not swing and collide with other rig equipment.



Pushing on the lift cylinder control valve handle (toward the center of the tong) will cause the equipment to lift. This valve handle action applies to all CE-marked tongs and is regardless of control valve bank orientation.

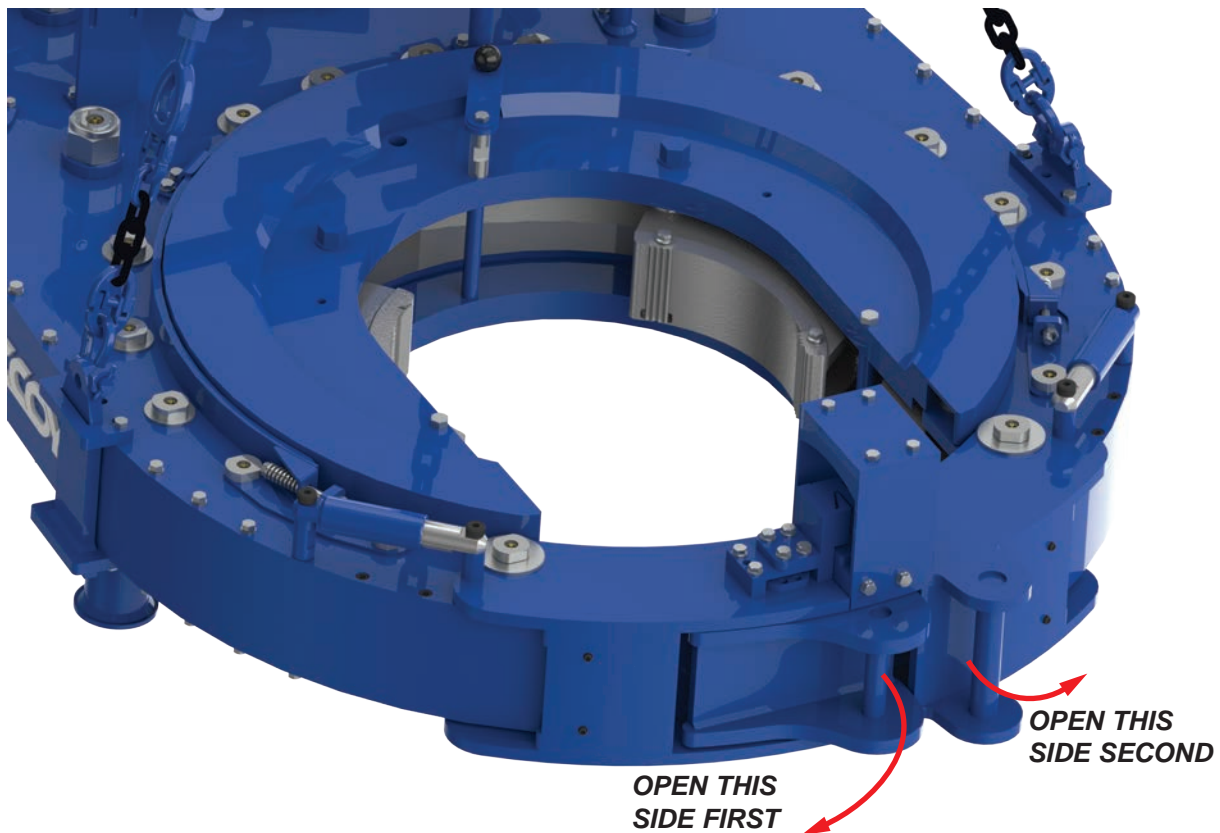


**RIG PERSONNEL MUST STABILIZE THE TONG AS IT IS LIFTED FROM THE DRILL FLOOR**

## 2.1.1 Making A Connection (Continued):

**ILLUSTRATION 2.1.3: LIFT CYLINDER CONTROL - RAISE**

5. Grasp the tong door latch and pull to open the door on the left side (as seen from the front of the tong). After the latch-side door is open grasp the handle on the second door and swing open. Since your equipment is equipped with safety doors, opening the door will inhibit rotation of the cage plate.

**ILLUSTRATION 2.1.4: OPENING TONG DOORS**

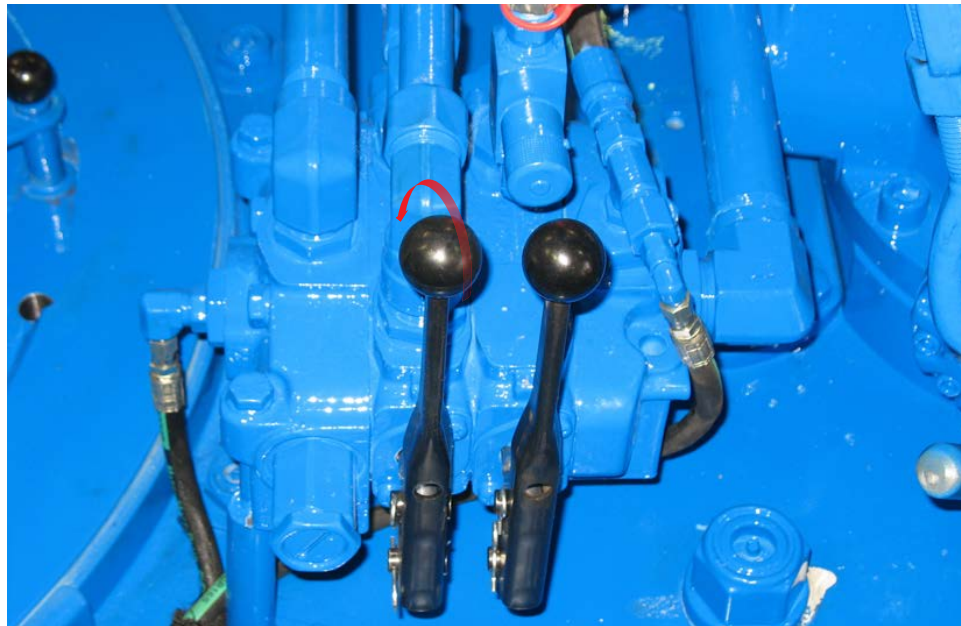


**2.1.1 Making A Connection (Continued):**

6. Manually engage the threads of the tubing connection being made up. Ensure threads are not cross-threaded.
7. Move the tong on to the tubing joint. Use the lift cylinder to ensure the tong jaws are at the correct location above the connection joint.
8. Firmly close the tong door on the right side (as seen from the front of the tong), followed by the latched door (on the left side as seen from the front). Tug firmly on the door handle on the right side (as seen from the front) to ensure the latch is firmly engaged.
9. Ensure tubing is roughly centered within the tong jaws - rig personnel are required to stabilize the tong above the connection until the jaws have been cammed on to the pipe or casing.
10. Begin rotation with the tong in high gear (high speed/low torque). See Section 2.H.4 to properly set the tong to high gear. Do not shift gears while the tong is rotating.

**SHIFTING TONG WHILE ROTATING THE MOTOR AND CAGE PLATE MAY RESULT IN CATASTROPHIC GEAR TRAIN FAILURE**

11. Push the motor control valve toward the tong to rotate the cage plate in the make-up direction.



**ILLUSTRATION 2.1.5: MOTOR CONTROL - MAKE-UP**

12. When the tong jaws cam on to the tubing push the rotation control handle all the way in to thread the connection together at high speed. As the joint becomes fully made up the increasing torque demand will stall the motor, and displayed torque will increase.
13. Stop rotation and shift to low gear (low speed/high torque). See Section 2.H.4 for instructions for shifting to low gear. This will enable the tong to produce adequate torque for making up the joint to specification.

### 2.1.1 Making A Connection (Continued):

14. Push the rotation control handle all the way in to complete the connection at low speed/high torque. Observe the torque gauge - when the specified make-up torque is reached stop rotation. Reverse the rotation control valve to release the tong jaws from the tubing (see Illustration 2.1.6).

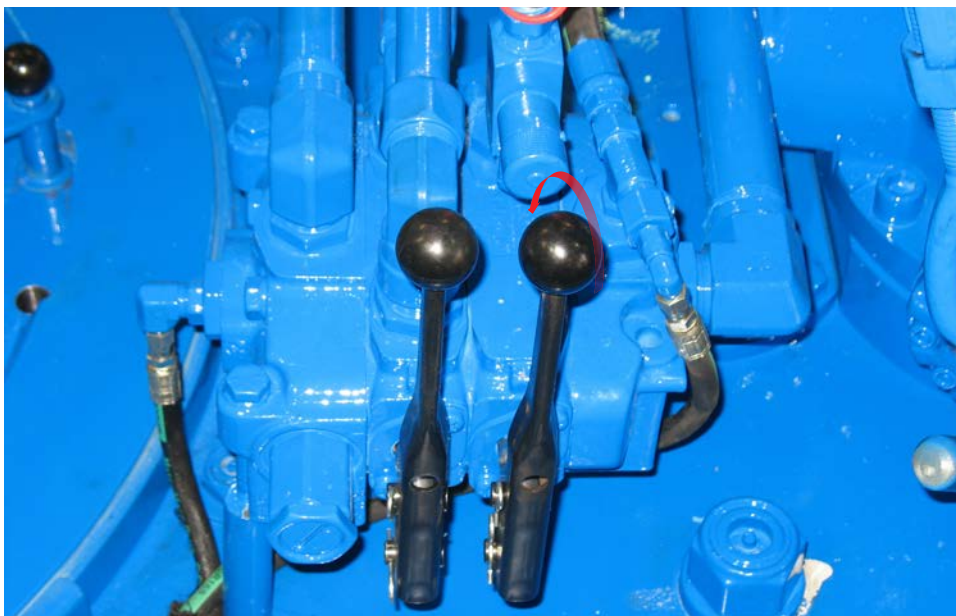


**ILLUSTRATION 2.1.6: MOTOR CONTROL - RELEASING JAWS**

15. When tong jaws are free, align the opening in the rotary gear with the mouth of the tong, and open the tong doors to free the tong from the drill string. Note that rig personnel may be required to stabilize the tong as it completely releases from the drill string. Guide the tong away from the string and push the lift cylinder control handle to lower it to the drill floor if desired.



Pulling on the lift cylinder control valve handle (toward the operator) will cause the equipment to lower. This valve handle action applies to all CE-marked tongs and is regardless of control valve bank orientation.



**ILLUSTRATION 2.1.7: LIFT CYLINDER CONTROL - LOWER**

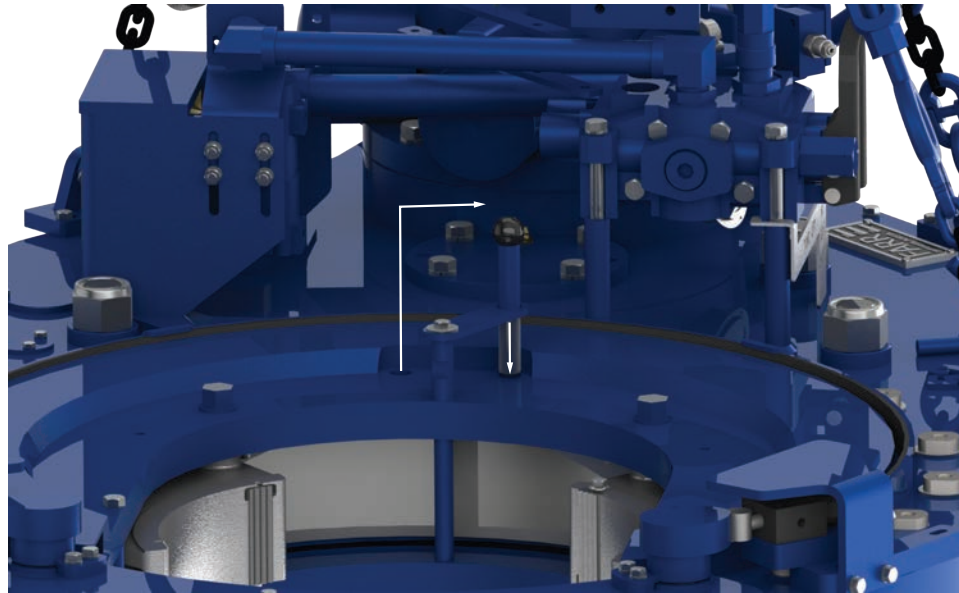
16. Repeat steps 6 through 15 until the desired number of connections are made up.

## 2.1.2 Breaking A Connection



**YOUR TONG SHOULD BE PROPERLY SUSPENDED, CONNECTED TO A HYDRAULIC POWER SOURCE, AND READY TO BREAK CONNECTIONS.**

1. Ensure hydraulic power supply to the tong and backup is energized. The master link on the rigid sling must be used to suspend the tong. Do not suspend the tong from any other point. See Illustration 2.1.1.
2. Set the backing pin for “breakout” operation. Lift up on the backing pin and rotate it to the “breakout” position, which is 2 o’clock as seen from the front of the tong. The opening in the rotary gear must be aligned with the tong door opening in order to properly set the backing pin (see Illustration 2.1.8).



**ILLUSTRATION 2.1.8: SETTING BACKING PIN TO “BREAK-OUT” POSITION**

3. Ensure the load cell is configured for break-out operation. If torque measurement for break-out is required, connect the load cell to the off-driller’s side (the right-hand side as seen from the rear of the tong).
4. Connect snub lines to the rear of the tong to arrest uncontrolled rotation of the assembly. The snub lines must be rated for the applied torque plus whatever safety margins stated by your own operating policies. The snub line connection points on the drill floor must be sturdy enough to absorb all applied and potential forces.
5. Open the tong door (see Illustration 2.1.4).
6. Actuate the lift cylinder control valve to lift the assembly from the drill floor. Pull the valve toward the operator to retract the lift cylinder to lift the assembly (see illustration 2.1.4). Note that rig personnel are required to stabilize the tong and backup as it is being lifted so it does not swing and collide with other rig equipment.



Pushing on the lift cylinder control valve handle (toward the center of the tong) will cause the equipment to lift. This valve handle action applies to all CE-marked tongs and is regardless of control valve bank orientation.



**RIG PERSONNEL MUST STABILIZE THE TONG AS IT IS LIFTED FROM THE DRILL FLOOR**

7. Move the tong on to the tubing joint. Use the lift cylinder to ensure the tong jaws are at the correct location above the connection joint.
8. Firmly close the tong door against the latch post.
9. Ensure tubing is roughly centered within the tong jaws - rig personnel are required to stabilize the tong above the connection until the jaws have been cammed on to the pipe or casing.



**2.1.2 Breaking A Connection (Continued):**

10. Breakout torque is only available when tong is in low gear. See Section 2.H.4 for instructions on shifting your tong to low gear. Do not shift gears while the tong is rotating.



**SHIFTING TONG WHILE ROTATING THE MOTOR AND CAGE PLATE MAY RESULT IN CATASTROPHIC GEAR TRAIN FAILURE**

11. Pull the motor control valve toward the operator to rotate the cage plate in the break-out direction.



**ILLUSTRATION 2.1.9: ROTATION CONTROL - BREAK-OUT**

12. When the tong jaws cam on to the tubing pull the rotation control handle all the way out to break the connection.
13. When the connection breaks stop rotation and shift to high gear (see Section 2.H.4 to shift to high gear). This will enable the tong to completely un-thread the connection at high speed.
14. Pull the rotation control handle all the way out to completely un-thread the connection. Reverse the rotation control handle (push toward tong) to release the tong jaws from the tubing (see Illustration 2.1.10).



**ILLUSTRATION 2.1.10: RELEASING TONG JAWS FOLLOWING BREAK-OUT & UN-THREADING**

**2.1.2 Breaking A Connection (Continued):**

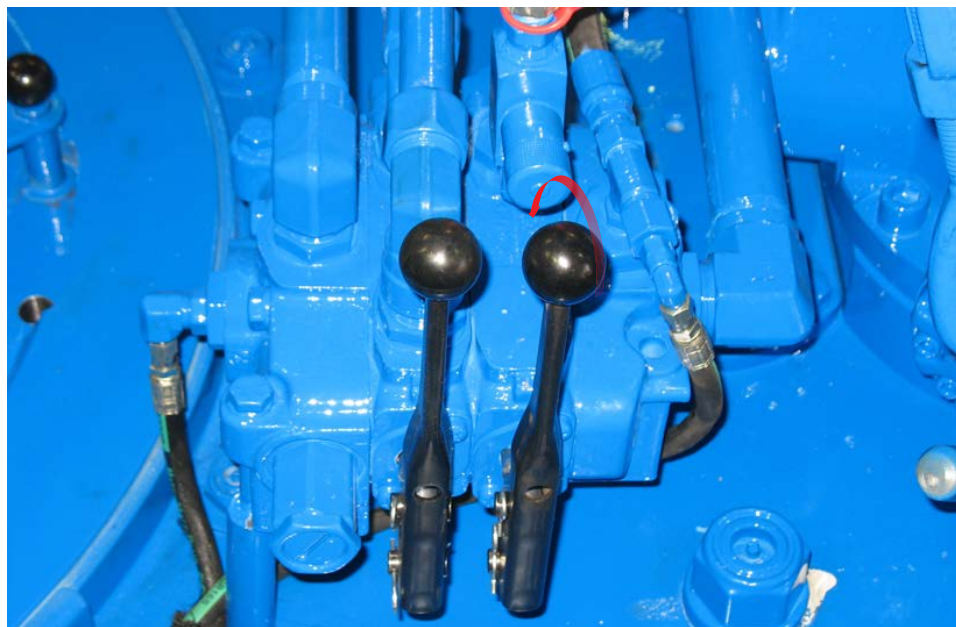
15. When the tong jaws disengage align the opening in the rotary gear with the mouth of the tong, and open the tong door to free the tong from the drill string. Unlatch and open the tong door to free the assembly from the tubing. Note that rig personnel may be required to stabilize the equipment as it completely releases from the tubing. Guide the assembly away from the string and push the lift cylinder control handle to lower it to the drill floor if desired.



**RIG PERSONNEL MUST STABILIZE THE TONG AS IT IS LOWERED TO THE DRILL FLOOR**



Pulling on the lift cylinder control valve handle (toward the operator) will cause the equipment to lower. This valve handle action applies to all CE-marked tongs and is regardless of control valve bank orientation.



**ILLUSTRATION 2.1.11: LOWERING TONG USING LIFT CYLINDER CONTROL**

- 16 Use your rig's standard pipe handling procedures to remove and rack the freed tubing stand.
- 17 Repeat steps 5 through 16 as many times as necessary to break out and un-thread the desired number of connections.

**2.J EXTREME COLD WEATHER OPERATION PROCEDURES**

1. Consult the power unit engine operator's manual for all cold weather operating procedures and precautions.
2. Select gear and bearing lubricants that are compatible with expected climatic conditions.
3. Select hydraulic fluid that is compatible with expected climatic conditions.
4. Allow hydraulic fluid to circulate for approximately 20 minutes after starting the power unit, prior to activating the bypass valve to allow fluid to circulate to tong. If the power unit is equipped with an oil temperature gauge, ensure that the fluid has reached operating temperature as specified by hydraulic fluid data sheet.
5. Allow for adequate drying of moisture (prior to lubricating) when cleaning tong parts in cold weather.



**This page intentionally  
left blank**



SECTION 3: MAINTENANCE



**This page intentionally  
left blank**



McCoy Global recognizes that minor on-site repairs and modifications are required to maintain peak operating condition of your equipment, or to match your equipment with the operating environment. Examples of minor repairs are

- replacement of damaged hydraulic hoses and fittings.
- replacement of malfunctioning pressure gauges and valves.
- replacement of door spring stop cylinders
- replacement of fasteners

Any replaced component must be an identical component supplied by McCoy Completions & Drilling. Replaced fasteners must be Grade 8 or equivalent, or whatever fastener is specified by McCoy.

### 3.A GENERAL MAINTENANCE SAFETY PRACTICES

The practices identified here are intended as a guideline. All personnel are responsible for performing their tasks in a manner that ensures worker, equipment, and environmental safety, and may require taking additional steps that are not identified in this section.

Equipment maintenance shall be performed only by designated qualified maintenance personnel. Wear all personal protective equipment (PPE) specified by your company's HSE policy, and follow all of your company's safety guidelines. Do not begin a maintenance task without the proper tools or materials on hand, or the proper drawings and documentation necessary.

Schedule planned maintenance with operators to avoid conflicts, unnecessary downtime, and the danger of accidental equipment activation. Notify operations when maintenance procedures are complete and equipment functionality is restored and tested.

If on-site maintenance must be performed (in other words, if equipment cannot be transported to a controlled maintenance facility) isolate the location of the maintenance to prevent unaware personnel from inadvertently exposing themselves to a hazard. Use tape, rope, or signage to clearly indicate "off-limits" area.

Replacement of large, heavy individual parts and/or heavy structural components must be performed using an approved lifting device of sufficient lifting capacity. Use care when attaching the lifting device, and safeguard area to avoid endangering personnel or equipment.

All spare parts must meet or exceed OEM specifications in order to maintain equipment integrity, especially protective equipment.



### **DO NOT PERFORM MAINTENANCE UNTIL TUBULAR CONNECTION EQUIPMENT HAS BEEN COMPLETELY ISOLATED FROM HYDRAULIC POWER**

Your equipment uses materials that may be harmful to the environment if improperly disposed of (hydraulic fluid, grease, etc.). Dispose of all materials according to your company's proscribed environmental protection regulations.

### 3.B CLEANING

Clean tong thoroughly cleaned with a good petroleum-based cleaning agent after each job, prior to storage. McCoy Global recommends that the motor and valve assembly be periodically removed, along with the top tong plate, so that guides, rollers and gears can be properly cleaned (see Section 3.H, Overhaul). Ensure that cleaning solvents and chemicals are captured to prevent environmental contamination, and dispose of all materials according to your company's proscribed environmental protection regulations.

### 3.C PREVENTIVE MAINTENANCE PRACTICES

Regular maintenance programs are necessary, and must be established to assure safe, dependable operation of your Hydraulic Tubular Connection System and to avoid costly breakdown maintenance. The following maintenance procedures provides information required to properly maintain your equipment. Your equipment may require more, or less maintenance depending upon the frequency of use and the field conditions under which your equipment operates. These maintenance procedures are designed for equipment operating at 10°C to 35°C ambient temperature for 10 hours per day. McCoy recommends that the inspection and maintenance procedures in this section be performed as recommended in the maintenance checklists (see Appendices), or in conjunction with your maintenance foreman's experience and best estimate of when your equipment is due for this maintenance.

Manufacturers of purchased components included with your hydraulic tubular connection equipment (for example: motors, valves, etc.) may specify maintenance tasks and intervals over and above what McCoy recommends as part of their recommended procedures. Users of this equipment may choose to perform or ignore these additional tasks at their discretion.

Filtration of the hydraulic fluid must be 10 microns or better. Premature fouling of particulate filters within your prime mover or ancillary hydraulic power unit requires immediate hydraulic fluid laboratory analysis to prevent premature wear of hydraulic system due to high levels of wear metals in the fluid.

McCoy Global recommends tracking all maintenance activity including the lubrication schedule and replacement of hydraulic hoses. This may be a simple as keeping a paper log, or using a software-based maintenance tracking utility. A maintenance log is a valuable tool that can be used for easily retrieving maintenance history or identifying trends that require correction.

**3.D HYDRAULIC SYSTEM DE-PRESSURIZATION**

McCoy Drilling & Completions recommends that the hydraulic system be de-pressurized prior to maintenance on any hydraulic component. Perform the following steps to ensure the dangers posed by hydraulic fluid under pressure are minimized.



**ENSURE ADEQUATE CONTAINMENT IS IN PLACE TO PREVENT ENVIRONMENTAL CONTAMINATION FROM RESIDUAL HYDRAULIC FLUID**

1. Rotate the tong to the “open throat” position. Ensure tong and backup doors (if equipped) are closed. Fully extend the lift cylinder
2. De-energize the power unit.
3. Repeatedly actuate the tong motor control valve lever IN BOTH DIRECTIONS to dissipate any residual pressure in the valve and motor.
4. Remove the hydraulic SUPPLY line from the equipment.
5. Repeatedly actuate the remaining control valve levers IN BOTH DIRECTIONS to dissipate any residual pressure in the remainder of the hydraulic control system.
7. Disconnect the hydraulic RETURN line from the equipment.
8. Disconnect remaining hoses such as case drains, or lines connected to the turns counter.



**HYDRAULIC PRESSURES AS HIGH AS OPERATING PRESSURE MAY REMAIN TRAPPED IN SMALL AREAS OF THE EQUIPMENT. ENSURE ALL MAINTENANCE IS CARRIED OUT BY A QUALIFIED SERVICE TECHNICIAN, AND THAT ADEQUATE PERSONAL PROTECTIVE EQUIPMENT IS USED TO GUARD AGAINST PRESSURE INJURIES**

**3.E LUBRICATION INSTRUCTIONS**

Use a quality multipurpose bearing lubricant that will remain within its viscosity range at expected operating temperatures. In addition, McCoy Global recommends the following lubrication procedure at the completion of each job prior to storage. McCoy recommends that a coating of grease be applied to the cam surface of the rotary gear prior to jaw installation.

**3.E.1 Cage Plate Cam Followers**

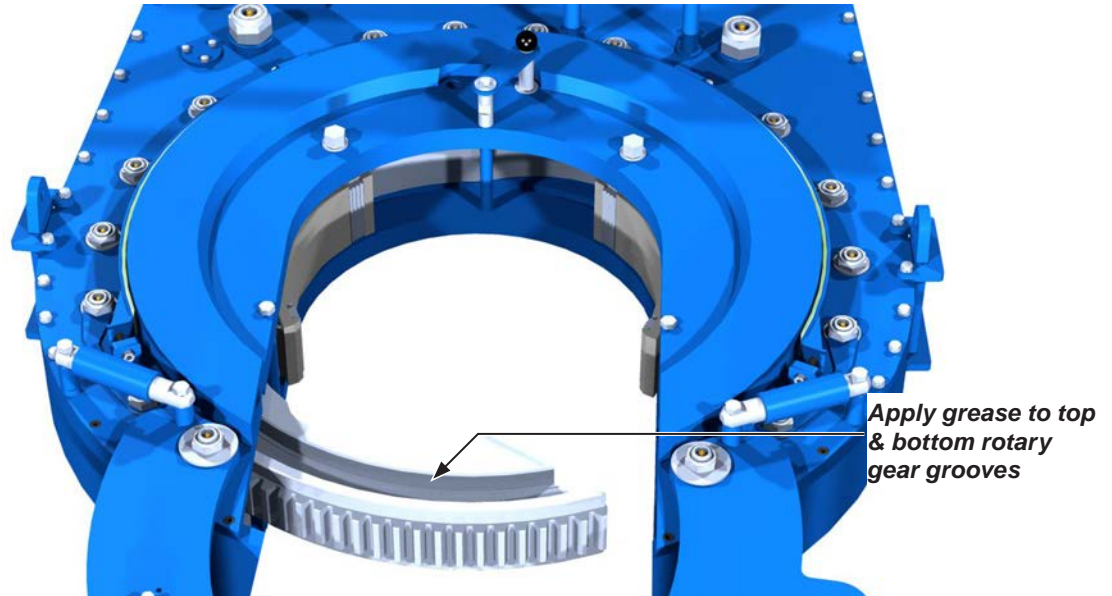
The cage plate cam followers are sealed units, and do not require lubrication. However, the cage plate and rotary gear grooves in which the cam followers ride should be lightly greased. When the cage plate is rotated as a unit, the cam followers are exposed, and can be greased. Continue rotating the cage plate assembly until all cam followers, top and bottom, are greased (see illustration 3.E.1).



**ILLUSTRATION 3.E.1: CAGE PLATE CAM FOLLOWER LUBRICATION**

**3.E.1 Cage Plate Cam Followers (Continued):**

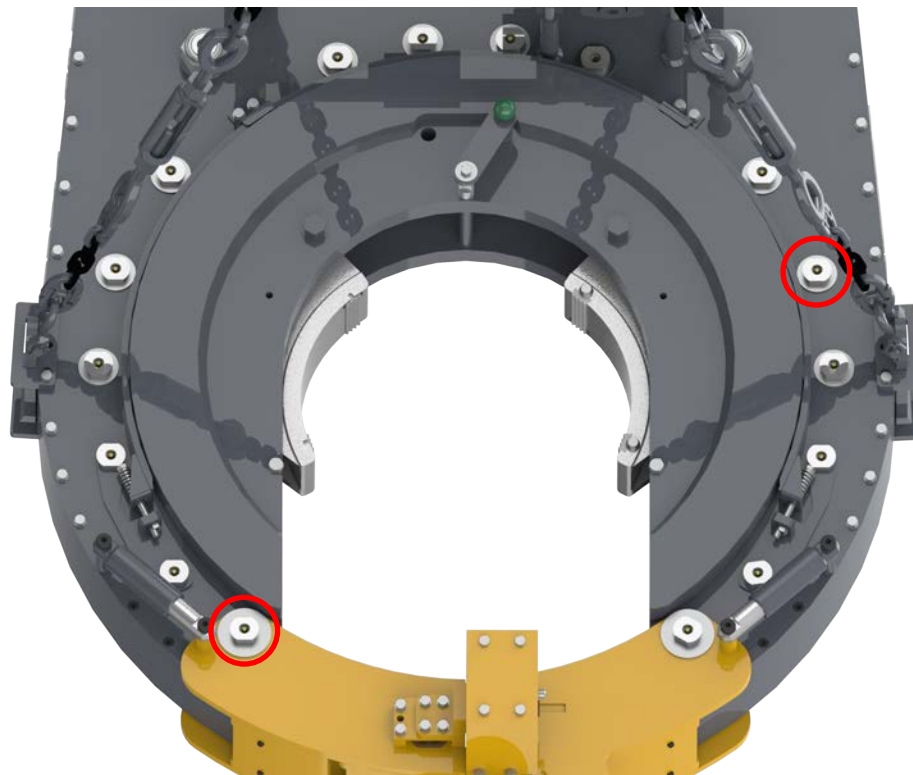
Rotate the rotary gear into the mouth opening as illustrated below. Apply grease to the top and bottom cage plate grooves. Continue to rotate the rotary gear and lubricate the grooves until the gear is well lubricated.



**ILLUSTRATION 3.E.2: ROTARY GEAR LUBRICATION**

**3.E.2 Support Roller Bearings**

Lubricate support roller bearings through the grease fittings in the top ends of the support roller shafts (16 locations total).



**ILLUSTRATION 3.E.3: SUPPORT ROLLER LUBRICATION**

### 3.E.3 Rotary Idler Bearings

Apply grease to these bearings through the grease fittings in the ends of the rotary idler shafts (2 locations total), located on the top face of the tong.



**ILLUSTRATION 3.E.4: ROTARY IDLER LUBRICATION**

### 3.E.4 Pinion Idler Bearings

Apply grease to these bearings through the grease fittings in the ends of the idler half shafts, located on the bottom face of the tong (2 locations total).

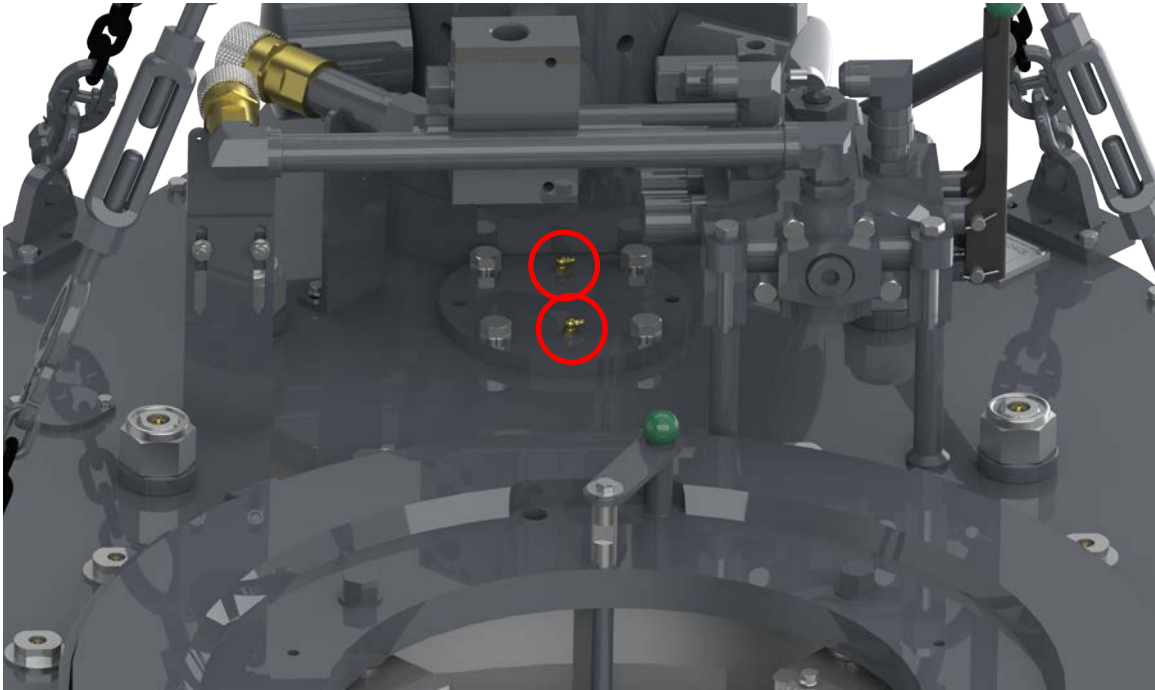


**ILLUSTRATION 3.E.5: PINION IDLER LUBRICATION**



### 3.E.5 Pinion Bearings

Apply grease to these bearings through the grease fittings in the pinion bearing caps, which are located on the top face of the tong under the hydraulics and on the bottom face of the tong between the pinion idlers (four locations total).



**ILLUSTRATION 3.E.6: PINION LUBRICATION**

### 3.E.6 Clutch Shaft

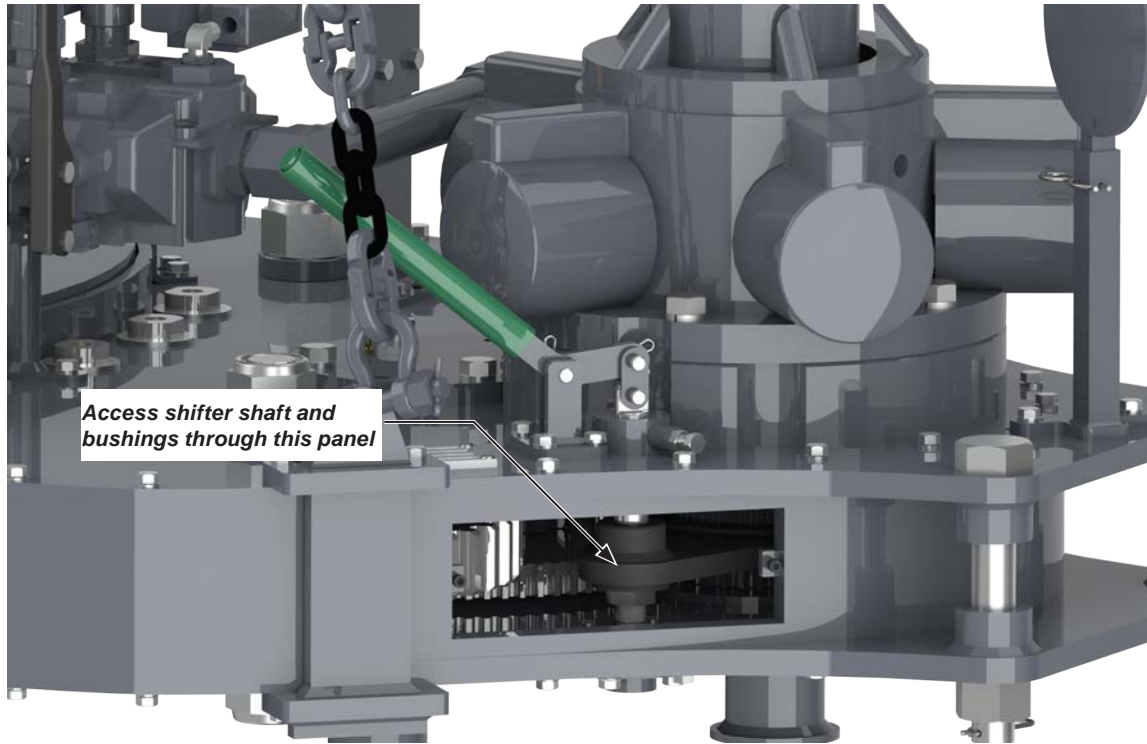
Apply grease to these bearings through the grease fittings in the clutch bearing cap which is located at the bottom face of the tong. Do not neglect to apply grease to the middle fitting, which is inset in the bearing cap.



**ILLUSTRATION 3.E.7: CLUTCH SHAFT LUBRICATION**

### 3.E.7 Shifting Shaft

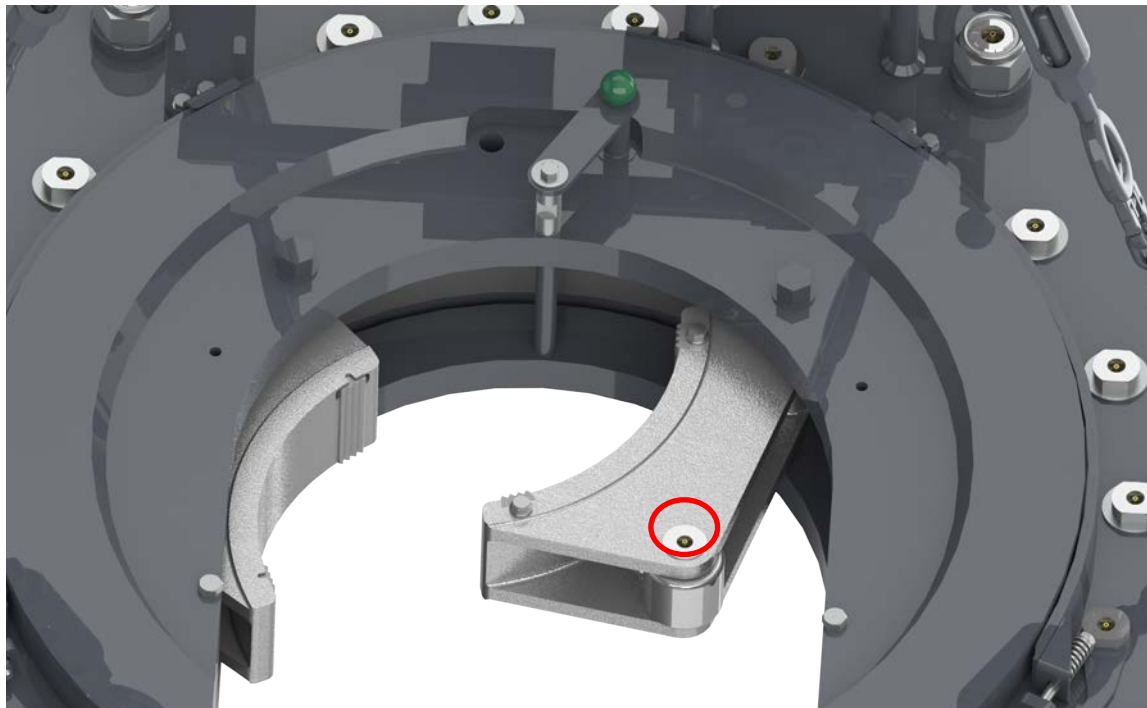
Apply grease to the shifting shaft and shifting shaft bushings, which may be accessed through the cover plate on the side of the tong.



**ILLUSTRATION 3.E.8: SHIFTER COMPONENT LUBRICATION ACCESS**

### 3.E.8 Jaw Rollers

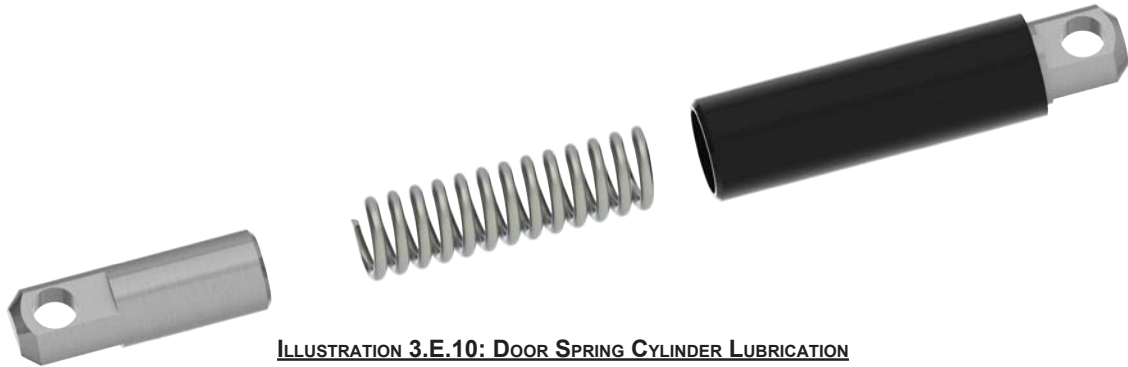
Apply grease to the jaw rollers through the grease fitting at the end of the jaw roller pin.



**ILLUSTRATION 3.E.9: JAW ROLLER LUBRICATION**

**3.E.9 Door Spring Stop Cylinder**

Periodically disassemble the door spring stop cylinders and coat the spring and cylinder with a general purpose lubricating oil.



**ILLUSTRATION 3.E.10: DOOR SPRING CYLINDER LUBRICATION**



**THE DOOR STOP CYLINDER SPRING MAY RETAIN ENERGY FROM BEING COMPRESSED. USE A CLAMP TO CONTAIN THE ENDS OF THE CYLINDER WHEN IT IS REMOVED, AND RELIEVE THE SPRING TENSION GRADUALLY.**

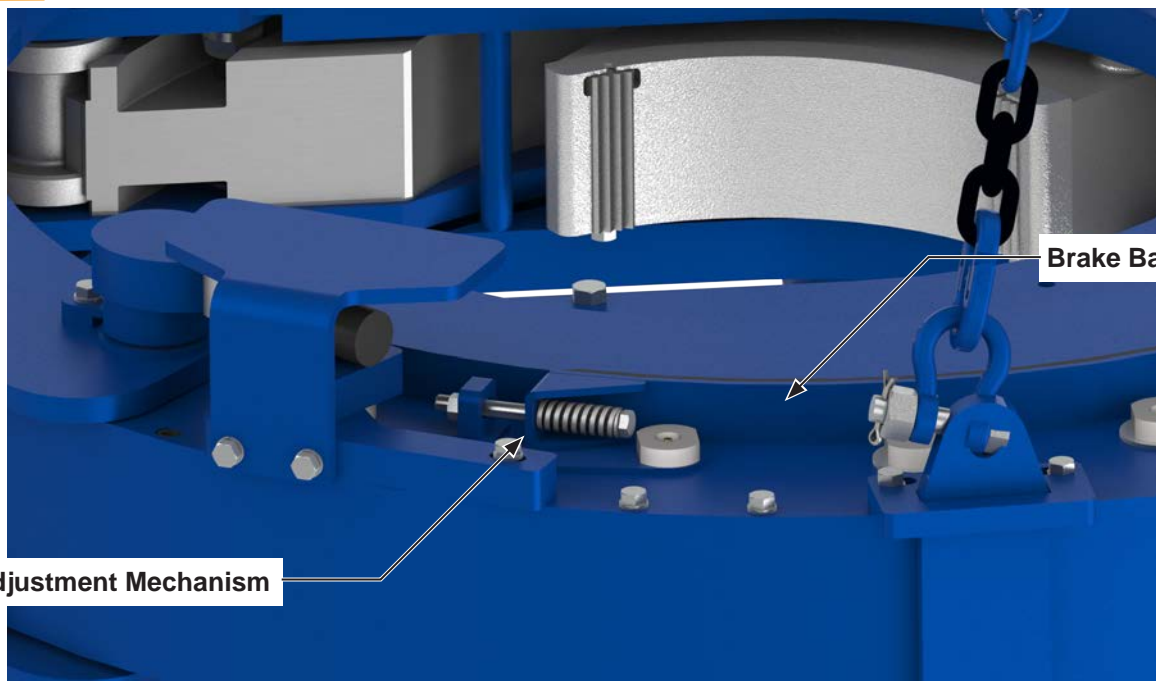
**3.F ADJUSTMENTS**

**3.F.1 Brake Band Adjustments:**

The brake bands must be periodically adjusted to continue to provide smooth and efficient jaw cam action. If the cage plate turns with the rotary gear, the jaws will not cam properly and, therefore, will not bite on the tubing or casing. Tightening the brake band against the cage plates will increase frictional resistance, allowing jaws to cam properly and grip the casing. Adjust the brake band using the adjustment nut and bolt set as shown in the illustration below. Do not over-tighten, as this causes excessive wear to the brake bands. Ensure top and bottom brake bands are adjusted at the same time.



**TOP AND BOTTOM BRAKE BANDS MUST BE ADJUSTED SIMULTANEOUSLY AND EQUALLY**



**ILLUSTRATION 3.F.1: BRAKE BAND ADJUSTMENT**

**3.F.2 Door Latch Adjustment:**

Normal operation of the tong may cause wear of the door latch, which will cause the door to develop a loose fit at the latch. Two latch cam plates are located on the right-hand door assembly, one on the top of the weldment and one on the bottom (see Illustration 3.F.2). The cam plates have eight positioning holes located on a 360 degree bolt circle. The latch cam shaft extends down through the door and is secured at the top by a 3/8" hex head bolt.

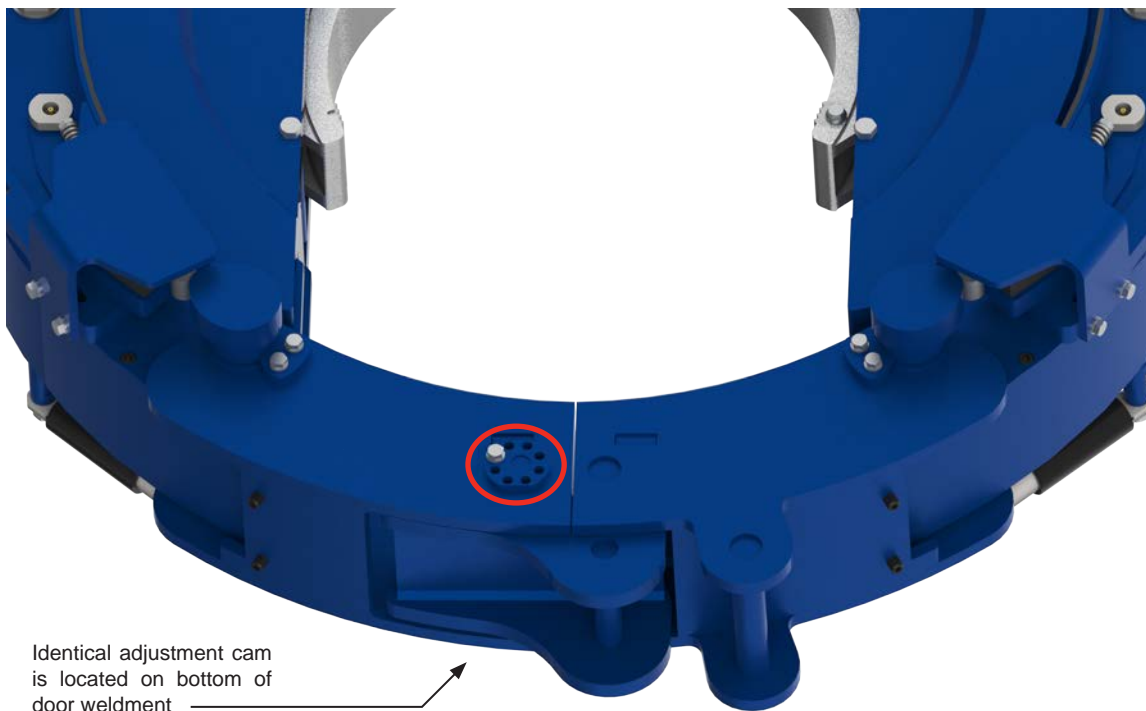
Remove the RH safety door latch claw and the RH safety door latch claw mount to expose the top door latch adjustment cam. To make adjustments in door alignment, remove the 3/8" bolt and turn the cams with a wrench. When the door latch has been adequately adjusted, replace the 3/8" bolt on each adjustment cam.



**ADJUST BOTH DOOR LATCH CAMS SIMULTANEOUSLY - ROTATE BOTH LATCH CAMS THE SAME AMOUNT IN THE SAME DIRECTION.**



**THE DOOR IS AN IMPORTANT PART OF THE STRUCTURAL INTEGRITY OF THE TONG. IT IS IMPERATIVE TO KEEP A SECURE FIT AT THE DOOR IN ORDER TO MAINTAIN PROPER GEAR ALIGNMENT, AND TO MINIMIZE THE POSSIBILITY OF DAMAGE TO THE GEAR TRAIN WHEN OPERATING THE TONG AT SPECIFIED TORQUE. A CLOSED DOOR ALSO ENSURES SAFETY OF OPERATING PERSONNEL.**



**ILLUSTRATION 3.F.2: DOOR LATCH ADJUSTMENT CAMS**

**3.F.3 Door Alignment**

Each door weldment is equipped with two set screws, along with jam nuts to lock position, to align the door when it is in the closed position.

**Initial Alignment**

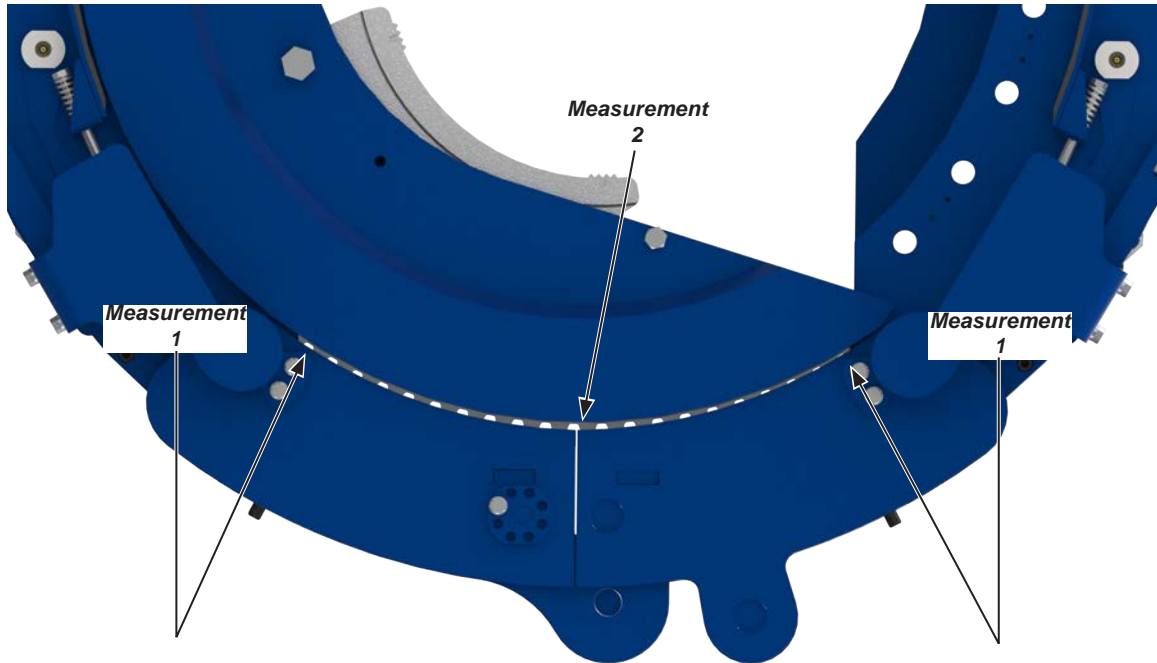
Ensure tong doors are closed, and inspect how one door aligns with the other at the point at which they meet. If misalignment is seen, choose one or the other door to adjust. Use a box-end wrench to loosen the lock nuts on the insides of the door weldment - the nuts may be accessed from the side of the door weldment. Use a hex key to turn the hex head set screws either clockwise or counter-clockwise to adjust the door. Note that the top and bottom of the door weldment may not need to be adjusted equally - each set screw should be adjusted independently until the doors are aligned.



**3.F.3 Door Alignment (Continued):**Final Alignment

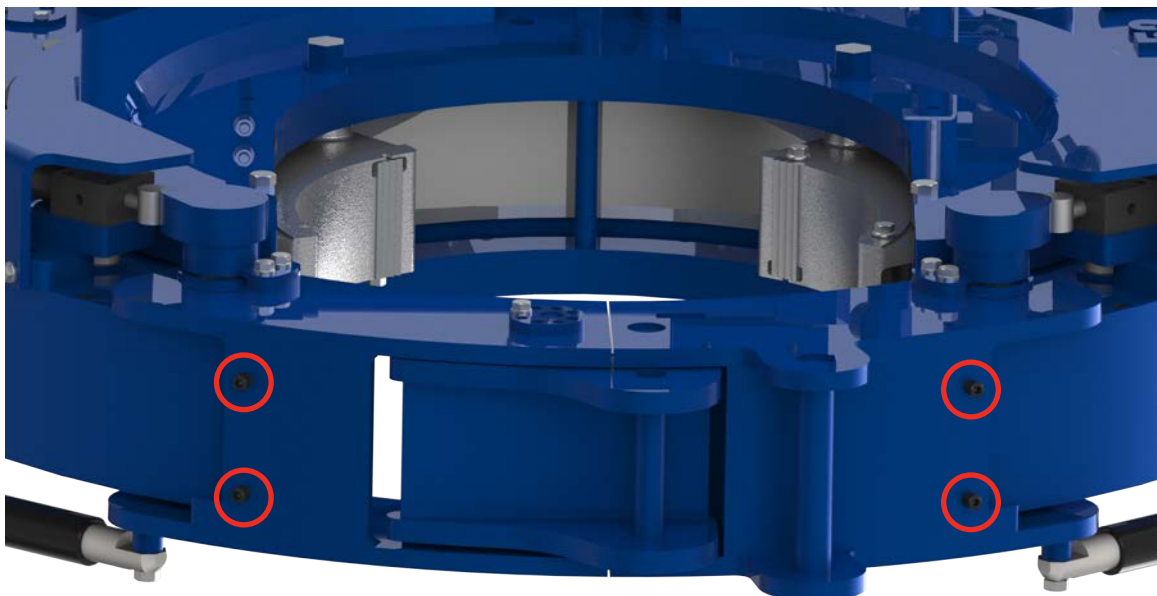
Rotate the cage plate, and stop it when the inside circumference of the door is completely covered. Perform three measurements (see illustration below):

1. From the insides of the outer edge of each door weldment to the cage plate (2 measurements total).
2. From the exact centre point (where the two doors meet) to the cage plate.



**ILLUSTRATION 3.F.3: DOOR ALIGNMENT MEASUREMENT POINTS**

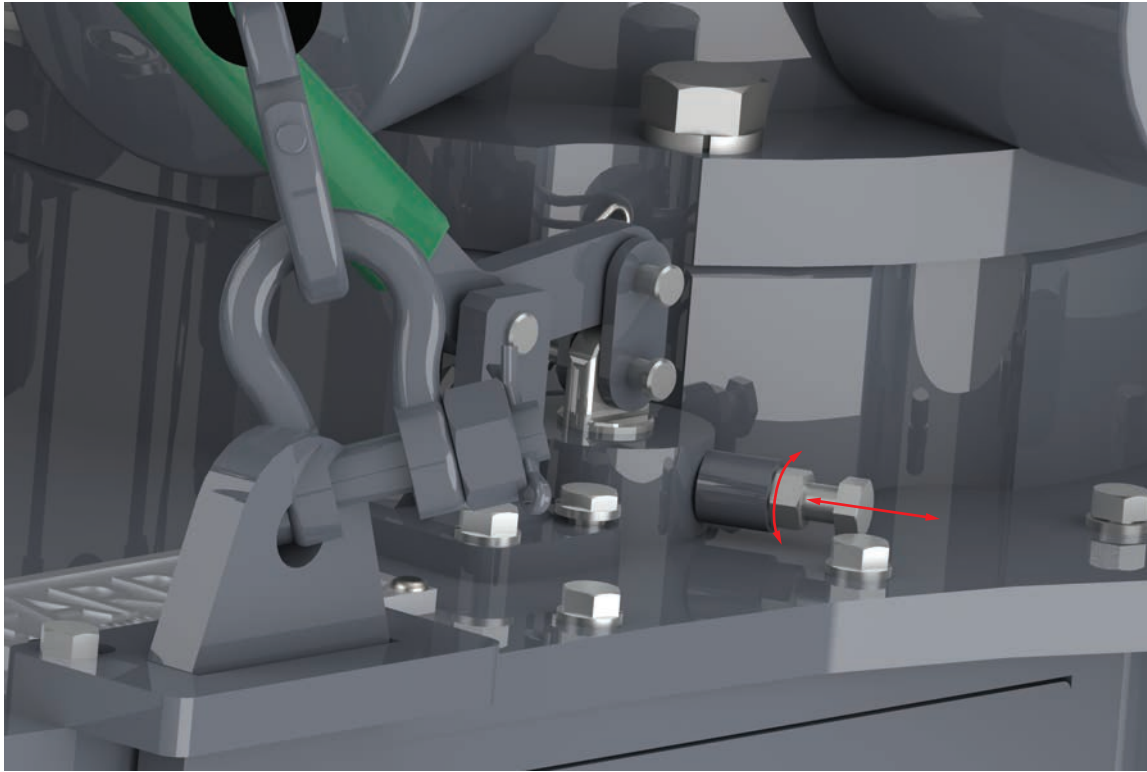
The three measurements should be equal. If the centre measurement is less than the two outside measurements, loosen all four locking nuts on the set screws, and turn all four set screws EQUALLY clockwise, until the centre measurement is equal to the two outer measurements. If the centre measurement is more than the two outside measurements, loosen all four locking nuts on the set screws, and turn all four set screws EQUALLY counter-clockwise, until the centre measurement is equal to the two outer measurements. Ensure that the locking nuts are tightened when this procedure is complete.



**ILLUSTRATION 3.F.4: DOOR ALIGNMENT ADJUSTMENT SET SCREWS**

**3.F.4 Shifter Detent Force Adjustment:**

Over time wear to the shifting shaft, wear to the detent ball, and loss of spring tension in the detent spring may result in a loose or “sloppy” fit within the top shifter bushing. The detent pressure may be increased or otherwise adjusted by loosening the 7/16” UNF locking jam nut, and turning the 7/16” UNF detent bolt. Should adequate detent action not be achieved, the shifting shaft, detent ball, or detent spring (or possibly all three) may need to be replaced (see Pp. 5.22 - 5.25).



**ILLUSTRATION 3.F.5: SHIFTER DETENT FORCE ADJUSTMENT**

**3.G RECOMMENDED PERIODIC INSPECTIONS****3.G.1 Door Stop Spring Cylinder**

The spring inside the spring stop cylinder must be of sufficient strength to enable the door latch mechanism to snap closed properly, and to hold the door in the open position when opened. Door stop spring fatigue will result in sluggish latch operation. Replace the latch spring inside the cylinder when this occurs.

**3.G.2 Backing Pin**

Perform a visual inspection of the backing pin after each job. Replace the pin if stress cracks or excessive wear is found, or if either pin is bent.

**3.G.3 Shifting Shaft**

The shifting yoke is secured to the shifting shaft by one hex jam nut above the shifting yoke, and one locknut on the bottom of the yoke. Check these nuts after each job. Do this by removing the clutch inspection plate and ensuring a snug fit prior to lubrication.

**3.G.4 Torque Gauge**

Periodic calibration of the torque gauge is recommended to assure accurate torque readings. When having the torque gauge serviced and calibrated, it is critical to note the arm length of the tong, as indicated in the “Specifications” section. McCoy Global recommends that the torque gauge assembly be calibrated yearly. Periodically check to ensure the load cell is filled with oil (see Section 6).

**3.H REMOVAL OF TOP PLATE FOR OVERHAUL**

The tong may be overhauled following the disassembly instructions in the following procedure. Access to the gear train is possible by removing the top plate of the tong.



**ALL MAINTENANCE AND OVERHAUL SHOULD BE PERFORMED FROM THE TOP. THE BOTTOM PLATE OF THE TONG IS TYPICALLY WELDED TO THE SIDE BODY AND CANNOT BE REMOVED.**



**REPLACEMENT FASTENERS (BOLTS, NUTS, CAP SCREWS, MACHINE SCREWS, ETC.) USED DURING MAINTENANCE OR OVERHAUL MUST BE GRADE 8 OR EQUIVALENT UNLESS OTHERWISE SPECIFIED.**

**TOP PLATE REMOVAL:**

1. Remove load cell assembly and load cell pins while tong is suspended (if equipped).
2. Securely support tong from the bottom. Ensure the supports are capable of supporting the entire weight of the tong.
3. Use a crane to remove the chain sling assembly. Store the chain sling in a location in which it will not be subjected to mechanical damage or corrosion.
4. Remove jaw assemblies if not already done.
5. Disconnect the hydraulic connections to the motor. Disconnect the hydraulic connections from the safety door switch. Contain hydraulic fluid spilled from disconnected lines and dispose in accordance with your company's environmental policies.
6. Undo the restraints securing the inlet and outlet lines connections to their supports, and use a crane to lift the hydraulic valve section away from the tong.
7. Remove the mounting posts for the valve bank. Remove the inlet and outlet support brackets.
8. Remove the torque gauge mount assembly from the rear top plate of the tong.
9. Remove the four tong hanger brackets.



The heads of the fasteners securing the chain sling hanger brackets are drilled, and are constrained to the brackets using wire ties. Wire ties must be removed before extracting the fasteners and removing the rigid sling hanger bracket.

10. Remove the top and bottom brake band assemblies.
11. Remove the tong doors:
  - i. Remove the door cylinders.
  - ii. Remove the thin nylock nuts and flat washers from the bottom of the two door pivot roller shafts.
  - iii. Ensure the door assemblies are well-supported when performing this next step. One door at a time, use a soft alloy material (e.g. brass rod, etc.) to lightly tap the shafts up through the support roller assembly until the shafts and large washers come free at the top. Use caution that the threads on the ends of the support roller shafts are not damaged.
12. Disconnect the shifting handle from the shifting shaft and shifting lug.
13. Remove the motor from the motor mount. Staffa motors are secured with five 3/4" bolts, while Rineer motors are secured with six 5/8" bolts. Inspect the splined motor shaft for clashing or spline damage.
14. Remove the motor mount by removing the five socket head cap screws. The motor mount can be lifted out of place. Take care not to lose the two position dowels - one, or both, may come off with the mount.
15. Remove the access panel on the body side adjacent to shifter assembly. Back off the detent adjustment bolt on the top shifter bushing. Remove the 7/8" jam nut from the shifting shaft to loosen the shifting fork. The shifting shaft may now be carefully rotated and pulled out of the top shifter bushing.



**THE CAGE PLATE BOLTS ARE THE ONLY ITEMS FASTENING THE BOTTOM CAGE PLATE TO THE TONG. SUPPORT THE BOTTOM CAGE PLATE FROM BELOW PRIOR TO REMOVING CAGE PLATE BOLTS IN ORDER TO PREVENT DAMAGE TO THE BOTTOM CAGE PLATE OR PERSONAL INJURY TO THE MECHANIC**

16. Remove the 3/8" hex bolt connecting the backing pin to the rear cage plate bolt. Remove the backing pin.
17. Remove the two front cage plate bolts, and the rear cage plate bolt, and the cage plate spacers. The cage-plates may now be removed. Use caution not to damage the cam followers while removing the cage plates.

**3.H REMOVAL OF TOP PLATE FOR OVERHAUL (CONTINUED):**

18. Pull the top bearing cap and spacer for the pinion drive gear by removing the four 5/8" bolts which secure the bearing cap. Thread two of the removed bolts into the extra holes on top of the bearing cap, and use them as lifting lugs to lift the bearing cap out of place.



**IF THE BEARING REMAINS ATTACHED TO THE GEAR SHAFT AFTER THE BEARING CAP IS PULLED, MCCOY SERVICE PERSONNEL RECOMMENDS LEAVING IT IN PLACE UNTIL THE TOP TONG PLATE IS REMOVED.**

19. Remove the top 1-1/2" nylock nuts and pads for the rotary and pinion idler gears.
20. Remove the thin nylock nuts and washers from all support roller shafts. One at a time, use a soft alloy material (e.g. brass rod, etc.) to lightly tap the shafts up through the support roller assemblies until the shafts and flat washers come free at the top. Use caution that the threads on the ends of the support roller shafts are not damaged. Note that the brake band lug weldments will come free when the support roller shafts are removed.
21. Remove the top plate fasteners (hex head bolts & socket head cap screws) around the perimeter of the tong which secure the top plate to the gear case housing. Note that the rear door cylinder mounting lugs must also be removed to release the top plate.
22. With all the above steps taken, the top tong plate can be lifted off providing access to the inside of the gear case. Use this opportunity to inspect the cam follower array mounted on the top plate - replace damaged cam followers.

3.1 ASSEMBLY PROCEDURES

Although the assembly of McCoy hydraulic power tongs is straightforward, and can be accomplished without the use of special tools, the instructions in this subsection are presented as a guide only and are similar to the assembly sequence our technician would use while assembling the tong in our plant.

**NOTE ON INSTALLATION PRACTICES:** Ensure all bearings are liberally greased before installing over a shaft or into gears or bearing caps. When inserting a shaft through a support roller assembly ensure shaft is greased. Also ensure all metal-to-metal contact in the gear train is adequately greased. **When graphics are not used in the assembly process, please refer to the relevant exploded diagrams in Section 5.**



**ALL FASTENERS USED DURING REASSEMBLY OF LOAD-BEARING COMPONENTS (CHAIN SLINGS, RIGID SLINGS, BACKUP LEGS) MUST BE TIGHTENED TO THE CORRECT TORQUE. THREADED FASTENERS USED IN LOAD-BEARING DEVICES MUST BE SECURED WITH RED LOCTITE™.**

TIGHTENING TORQUE GUIDE			
SAE GRADE 8 - FINE THREAD			
SIZE	CLAMP LOAD	PLAIN	PLATED
¼ - 28 (.250)	3,263	14 ft. lbs.	10 ft. lbs.
5/16 - 24 (.3125)	5,113	27 ft. lbs.	20 ft. lbs.
3/8 - 24 (.375)	7,875	49 ft. lbs.	37 ft. lbs.
7/16 - 20 (.4375)	10,650	78 ft. lbs.	58 ft. lbs.
½ - 20 (.500)	14,400	120 ft. lbs.	90 ft. lbs.
9/16 - 18 (.5625)	18,300	172 ft. lbs.	129 ft. lbs.
5/8 - 18 (.625)	23,025	240 ft. lbs.	180 ft. lbs.
¾ - 16 (.750)	33,600	420 ft. lbs.	315 ft. lbs.
7/8 - 14 (.875)	45,825	668 ft. lbs.	501 ft. lbs.
1 - 12 (1.000)	59,700	995 ft. lbs.	746 ft. lbs.
1 - 14 (1.000)	61,125	1019 ft. lbs.	764 ft. lbs.
1-1/8 - 12 (1.125)	77,025	1444 ft. lbs.	1083 ft. lbs.
1-1/4 - 12 (1.125)	96,600	2012 ft. lbs.	1509 ft. lbs.
1-3/8 - 12 (1.375)	118,350	2712 ft. lbs.	2034 ft. lbs.
1-1/2 - 12 (1.500)	142,275	3557 ft. lbs.	2668 ft. lbs.
SAE GRADE 8 - COARSE THREAD			
SIZE	CLAMP LOAD	PLAIN	PLATED
¼ - 20 (.250)	2,850	12 ft. lbs.	9 ft. lbs.
5/16 - 18 (.3125)	4,725	25 ft. lbs.	18 ft. lbs.
3/8 - 16 (.375)	6,975	44 ft. lbs.	33 ft. lbs.
7/16 - 14 (.4375)	9,600	70 ft. lbs.	52 ft. lbs.
½ - 13 (.500)	12,750	106 ft. lbs.	80 ft. lbs.
9/16 - 12 (.5625)	16,350	153 ft. lbs.	115 ft. lbs.
5/8 - 11 (.625)	20,325	212 ft. lbs.	159 ft. lbs.
¾ - 10 (.750)	30,075	376 ft. lbs.	282 ft. lbs.
7/8 - 9 (.875)	41,550	606 ft. lbs.	454 ft. lbs.
1 - 8 (1.000)	54,525	909 ft. lbs.	682 ft. lbs.
1-1/8 - 7 (1.125)	68,700	1288 ft. lbs.	966 ft. lbs.
1-1/4 - 7 (1.125)	87,225	1817 ft. lbs.	1363 ft. lbs.
1-3/8 - 6 (1.375)	103,950	2382 ft. lbs.	1787 ft. lbs.
1-1/2 - 6 (1.500)	126,450	3161 ft. lbs.	2371 ft. lbs.

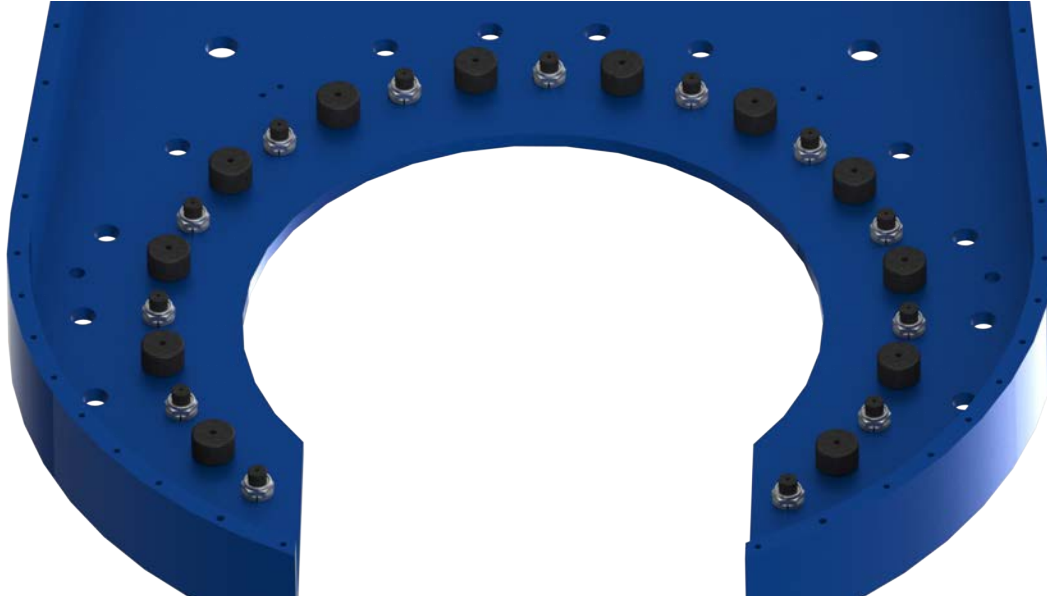


**REPLACEMENT FASTENER (BOLTS, NUTS, CAP SCREWS, MACHINE SCREWS, ETC.) USED DURING MAINTENANCE OR OVERHAUL MUST BE GRADE 8 OR EQUIVALENT UNLESS OTHERWISE SPECIFIED.**

**3.1 ASSEMBLY PROCEDURES (CONTINUED):**

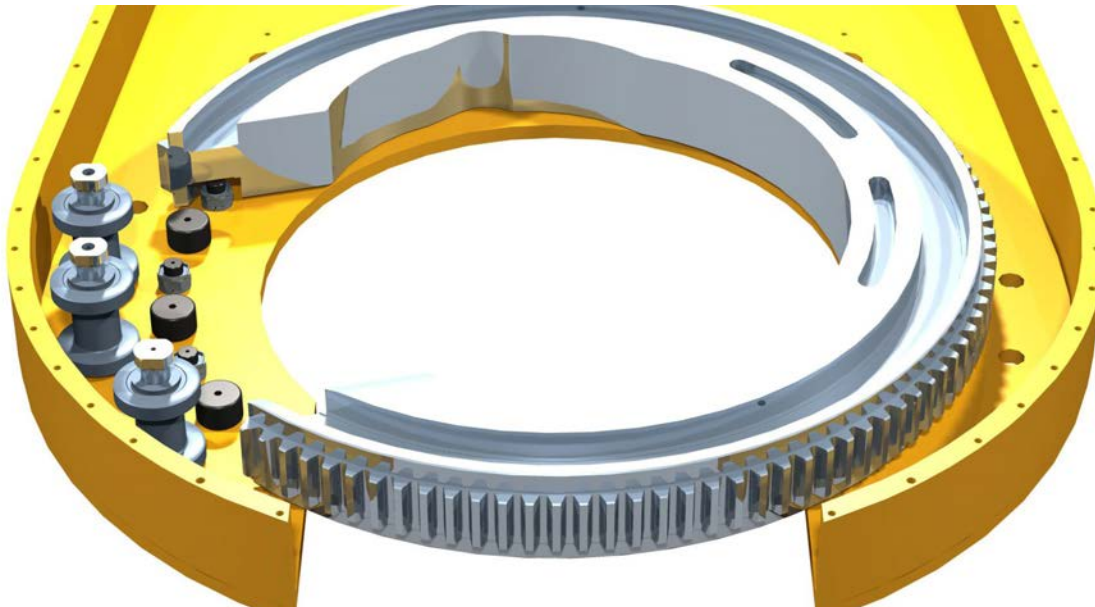
APPLY A THIN LAYER OF GREASE TO THE SURFACE OF EACH MOVING PART DURING ASSEMBLY TO AID IN THE ASSEMBLY PROCESS.

1. Position the tong body gear case on a suitable stationary support such that the bottom body plate is accessible.
2. Install 25 cam followers (PN 1037-0-58) into the bottom plate as shown in the illustration. Secure each with a  $\frac{7}{8}$ " lock washer and  $\frac{7}{8}$ " UNF jam nut.



**ILLUSTRATION 3.1.1: CAM FOLLOWER INSTALLATION - BOTTOM PLATE**

3. Insert support roller inner spacer (PN 1037-C-134) into each support ("dumbbell") roller. Press two support roller bearings (PN 02-0094) into each end of each support roller (16 assemblies total). Once the assembly of the support rollers is complete, temporarily slide the support roller shafts into each assembly for assistance in correctly positioning each support roller. NOTE: do not include the two door pivot rollers in this step - only perform this action with the fourteen body rollers.
4. Place rotary gear on bottom plate, over the cam followers installed in Step 2. Note that the backing pin grooves are in the top side of the rotary gear.
5. Rotate the rotary gear so that the opening in the gear faces the first three support roller positions closest to the mouth of the tong (do not include door pivot rollers at this point). Install three support roller assemblies, including shafts but not including fasteners, in the locations exposed in the rotary gear opening. Continue to rotate rotary gear around the tong, installing the support roller assemblies as the gear is rotated. Finish with the rotary gear aligned with the opening in the bottom plate.



**ILLUSTRATION 3.1.2: ROTARY GEAR & SUPPORT ROLLER INSTALLATION**



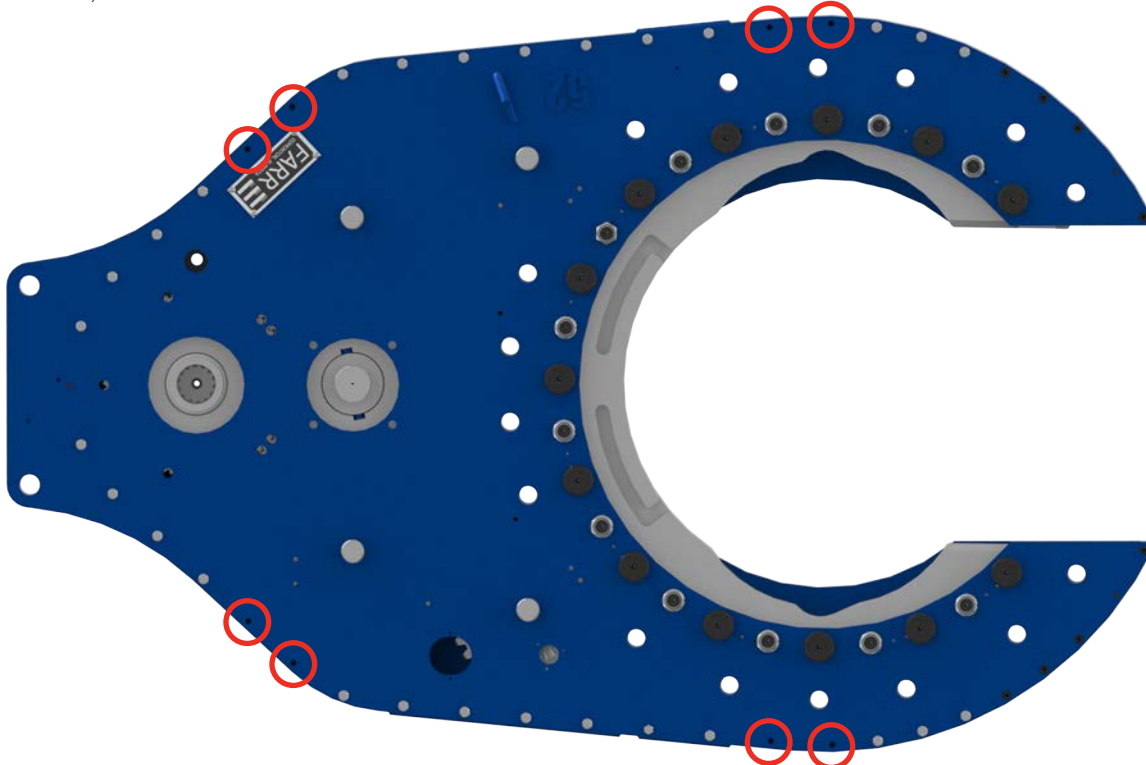
**3.1 ASSEMBLY PROCEDURES (CONTINUED):**

6. Press pinion bearing (PN 02-0106) into bottom pinion bearing cap (PN 1037-C-33), and install bearing cap into bottom plate of tong using four  $\frac{5}{8}$ " lock washers and four  $\frac{5}{8}$ " NC x 1-1/2" hex cap screws.
7. Press lower clutch bearing (PN 02-0105) into bottom clutch bearing cap (1037-C-17), and install bearing cap into bottom plate of tong using four  $\frac{5}{8}$ " lock washers and four  $\frac{5}{8}$ " NC x 1-1/2" hex cap screws.
8. Install a retaining ring (PN 02-0009) into each of the two rotary idler gears (one each of PN 1037-D59). Press one each of the idler bearings (PN 02-0011) into each of the rotary idler gears, followed by a second retainer ring in each. Slide each rotary idler gear and bearing assembly over an idler shaft (PN 1050-D5-117) and centre as well as you are able.
9. Slide a bearing seal (PN 02-0010) over each end of the rotary idler shafts, ensuring that the "lip" on the seals are towards the centre bearing, followed by an idler spacer (PN 1050-D5-121) over each end of the shafts.
10. Install each rotary idler in their respective locations in the bottom plate. ASSEMBLY NOTE: when the rotary idler assemblies are placed vertically, the bearing seal and idler spacer on the bottom side will have to be held in place by hand as the assembly is lowered through the bottom plate. Once the assembly is through the bottom plate, place an idler pad (PN 997-D20-125) over the bottom end of each shaft, and secure the pads with a 1-1/2" UNF hex nylock nut.
11. Slide low pinion gear (PN 1037-D-32) over bottom end of pinion gear shaft (PN 1037-D-15), and place end of pinion gear shaft into pinion bearing and bearing cap installed in Step 6. Ensure the gear keys (PN 1037-D-15A), are placed into the pinion gear shaft before installing gear (two keys per gear).
12. Install a retaining ring (PN 02-0009) into each of the two pinion idler gears (PN 1037-D-1). Press one each of the idler bearings (PN 02-0011) into each of the pinion idler gears, followed by a second retainer ring in each. Slide each pinion idler gear and bearing assembly over an idler shaft (PN 1050-D5-117) and centre as well as you are able.
13. Slide a bearing seal (PN 02-0010) over each end of the pinion idler shafts, ensuring that the "lip" on the seals are towards the centre bearing, followed by an idler spacer (PN 1050-D5-121) over each end of the shafts.
14. Install each pinion idler in their respective locations in the bottom plate. ASSEMBLY NOTE: when the pinion idler assemblies are placed vertically, the bearing seal and idler spacer on the bottom side will have to be held in place by hand as the assembly is lowered through the bottom plate. Once the assembly is through the bottom plate, place an idler pad (PN 997-D20-125) over the bottom end of each shaft, and secure the pads with a 1-1/2" UNF hex nut.
15. Slide clutch bearing (PN 02-0104) over the bottom end of the splined clutch shaft (PN 1037-D-38). Install two upper clutch bearings (PN 02-0103) over the top side of the clutch shaft. Press bearings tight to the center gear on the splined clutch shaft.
16. Slide the low clutch gear (PN 1037-D-40) over the lower bearing so that the larger diameter gear on the low clutch gear is tight to the center gear on the clutch shaft, and place end of clutch shaft into bottom clutch bearing installed in Step 7. Mesh the low clutch gear with the low pinion gear as it is installed.
17. Place the shifting collar (PN 1037-D-34) over the middle section of the clutch shaft.
18. Slide the high clutch gear (PN 1037-D-41) over the two top clutch bearings.
19. If not already done, insert the two remaining gear keys in the pinion gear shaft. Install the high pinion gear (PN 1037-D-12) over the top of the pinion gear shaft, meshing with the high clutch gear as it is installed.
20. Fasten the lower shifter bushing (PN 1037-C-21B) to the bottom plate with four  $\frac{3}{8}$ " UNC x 1-1/4" hex bolts and  $\frac{3}{8}$ " lock washers.
21. Place the shifting fork weldment (PN 1037-D-27) up against the shifting collar, roughly in its final position.
22. Install 25 cam followers (PN 1037-0-58) in the top plate (PN 1037-7-02) as shown in the illustration below. Secure with  $\frac{7}{8}$ " UNF jam nuts and  $\frac{7}{8}$ " lock washers.

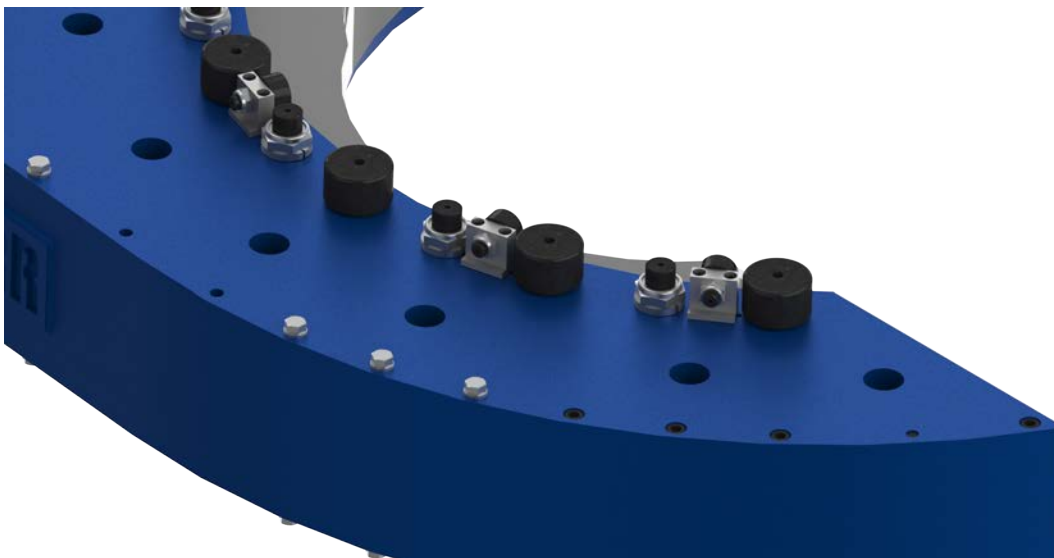
**ILLUSTRATION 3.1.3: TOP PLATE CAM FOLLOWER INSTALLATION**

**3.1 ASSEMBLY PROCEDURES (CONTINUED):**

23. Carefully remove all the support roller shafts, ensuring the support roller assemblies do not shift position as you are doing so.
24. Insert three  $\frac{3}{8}$ " x 1- $\frac{1}{2}$ " hardened ground production dowel pins into the side body - one at exact rear centre, and one on either side of the front opening. Position the top plate in its proper location - use caution not to damage threads when aligning the top plate with the idler and support roller shafts. Ensure the plate is aligned exactly horizontal to prevent binding on the dowel pins. Use caution when aligning the previously installed cam followers with the rotary gear. Tap plate securely into place with a rubber mallet.
25. Secure the top plate with twenty-seven  $\frac{3}{8}$ " UNC x 1- $\frac{1}{2}$ " hex bolts, two  $\frac{3}{8}$ " UNC x 1- $\frac{1}{4}$ " hex bolts (install these two above the removable access panel), and eight  $\frac{3}{8}$ " UNC x 1" hex socket cap screws. Note that fasteners are NOT to be installed at the chain sling hanger locations, circled in red in illustration 3.1.4.

**ILLUSTRATION 3.1.4: TOP PLATE FASTENER EXCLUSIONS**

26. Install ten horizontal cam follower guides (PN 1037-A-49) to the top side of the top plate, and secure with  $\frac{1}{4}$ " UNC x 1- $\frac{1}{4}$ " hex socket head cap screws and  $\frac{1}{4}$ " high-collar lock washers. Install ten horizontal cam followers (PN 02-0108) in the horizontal cam follower guides and secure each with a  $\frac{7}{16}$ " UNF jam nut and  $\frac{7}{16}$ " lock washer.

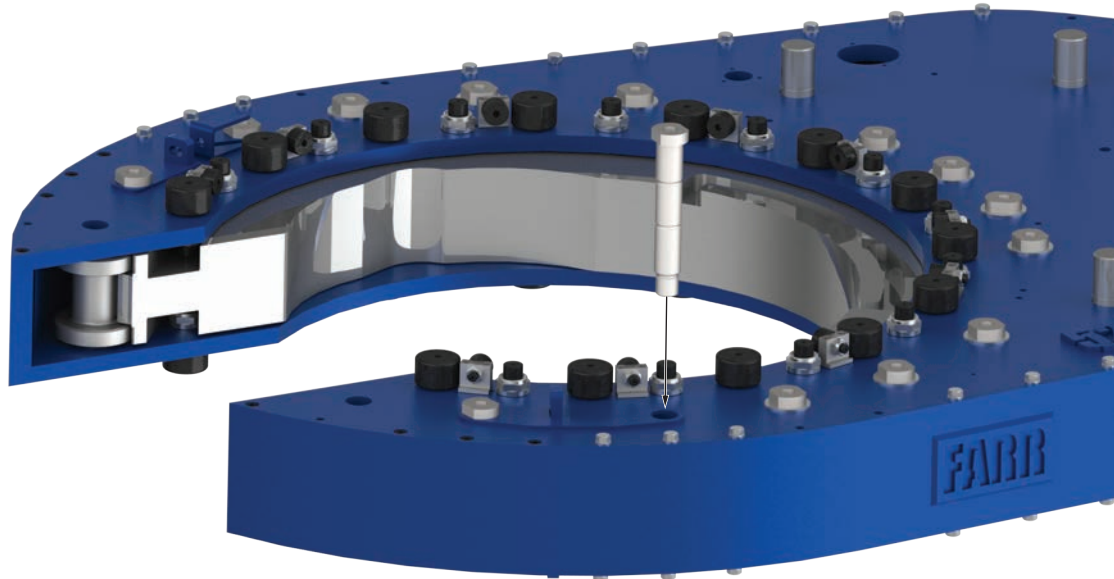
**ILLUSTRATION 3.1.5: INSTALLATION OF HORIZONTAL CAM FOLLOWERS AND GUIDES**

**3.1 ASSEMBLY PROCEDURES (CONTINUED):**

## 27. Re-install the support roller shafts:

Note that the two top and bottom brake band lug weldments (top RH and bottom LH weldments are PN 101-1636, and the top LH and bottom RH weldments are PN 101-1637) are retained by four support roller shafts (as shown in illustration below). Secure the support roller shafts with 1" UNF thin nylock nuts and 1" narrow flat washers (except where noted).

**ASSEMBLY NOTE:** 1" narrow flat washers are not used where the support roller shafts are coincidental with the brake band lug weldments.



**ILLUSTRATION 3.1.6: SUPPORT ROLLER - BRAKE BAND WELDMENT INSTALLATION**

28. Install the remaining 1-½" UNF nylock nuts and idler pads over the tops of the four idler assemblies.

29. Press the remaining bearing in the pinion assembly into the top pinion bearing cap (PN 1037-C-10), and install the bearing cap in the top plate of the tong using four ⅝" lock washers and four ⅝" UNC x 1-½" hex cap screws. Note that the flat on the bearing cap faces toward the rear of the tong.

30. Install motor mount and motor:

**TONGS EQUIPPED WITH THE RINEER MOTOR OPTION:**

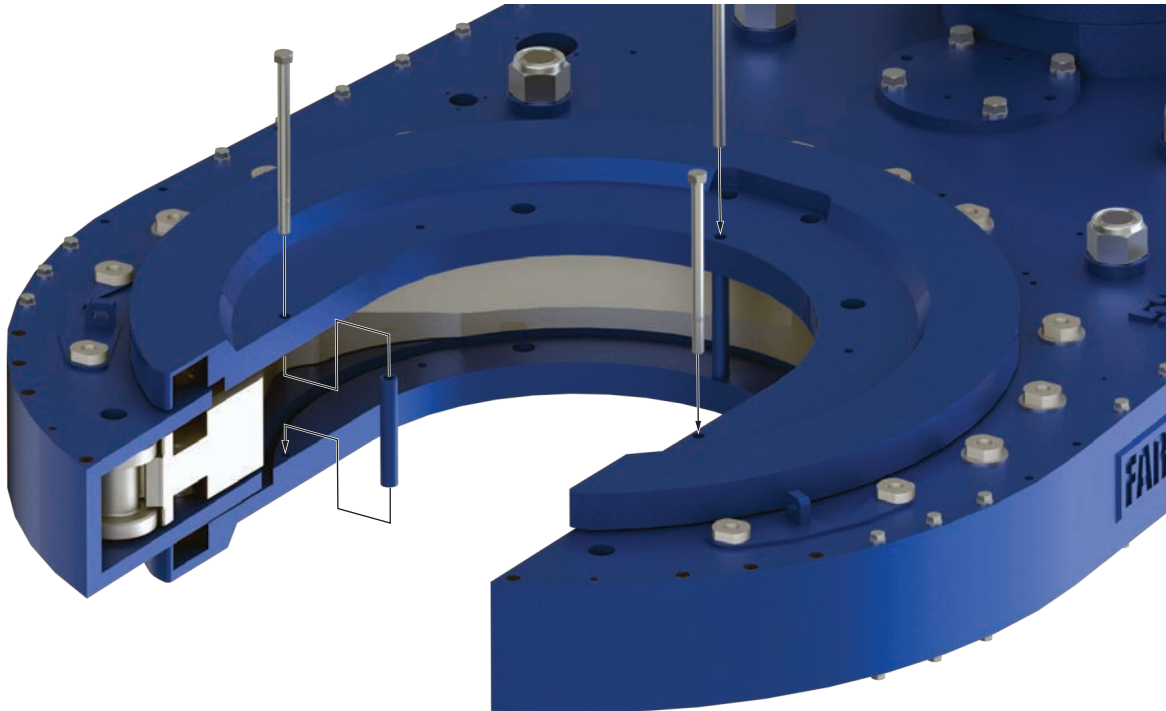
- i. Install the Rineer motor mount (PN 1426-7) on to the top plate. Correct orientation is such that one flat is against the flat on the top pinion bearing cap, and the second flat is on left side, directly adjacent to the clutch access panel. Secure the motor mount with five ¾" UNC x 1-¼" hex socket head cap screws and ¾" lock washers.
- ii. Install the top clutch shaft bushing (PN 1037-42) inside the centre of the motor mount.
- iii. Install Rineer hydraulic motor (PN 87-0150) on to the motor mount. Use caution to make sure the splines on the motor shaft are properly aligned with the grooves in the clutch shaft. Secure with five ¾" UNC x 2-½" hex bolts and ¾" lock washers.

**TONGS EQUIPPED WITH THE STAFFA MOTOR OPTION:**

- i. Place the motor thrust washer (PN 101-3289) over the top of the splined clutch shaft, followed by the motor spacer (PN 1037-D-38S).
  - ii. Install the motor mount (PN 1037-D-7) ensuring that the flat on the motor mount is oriented toward the pinion bearing cap and the "notch" in the motor mount is oriented to accommodate the top shifter bushing. Secure with five ¾" UNC x 1-¼" hex socket head cap screws and ¾" lock washers.
  - iii. Install Staffa hydraulic motor (PN 87-0210B) on to the motor mount. Use caution to make sure the splines on the motor shaft are properly aligned with the grooves in the clutch shaft. Secure with five ¾" UNC x 2-½" hex bolts and ¾" lock washers.
31. Guide the shifting shaft (PN 1037-C-20A) through the top shifter bushing, and secure to shifting fork weldment using two ⅞" UNF hex jam nuts. Once the shifting fork has been secured, place the bottom of the shifting shaft into the lower shifting bushing.
32. Attach the "toe" of the shifting handle weldment (PN 1037-D-20B) to the shift pivot lug weldment using a ⅝" x 1-½" clevis pin, and secure the clevis pin with a small hitch pin.
33. Bolt the shifter lug weldment (PN 101-0016) to the top plate next to the top shifter bushing using four ⅞" UNC x 1" hex bolts and ⅞" lock washers.

**3.I ASSEMBLY PROCEDURES (CONTINUED):**

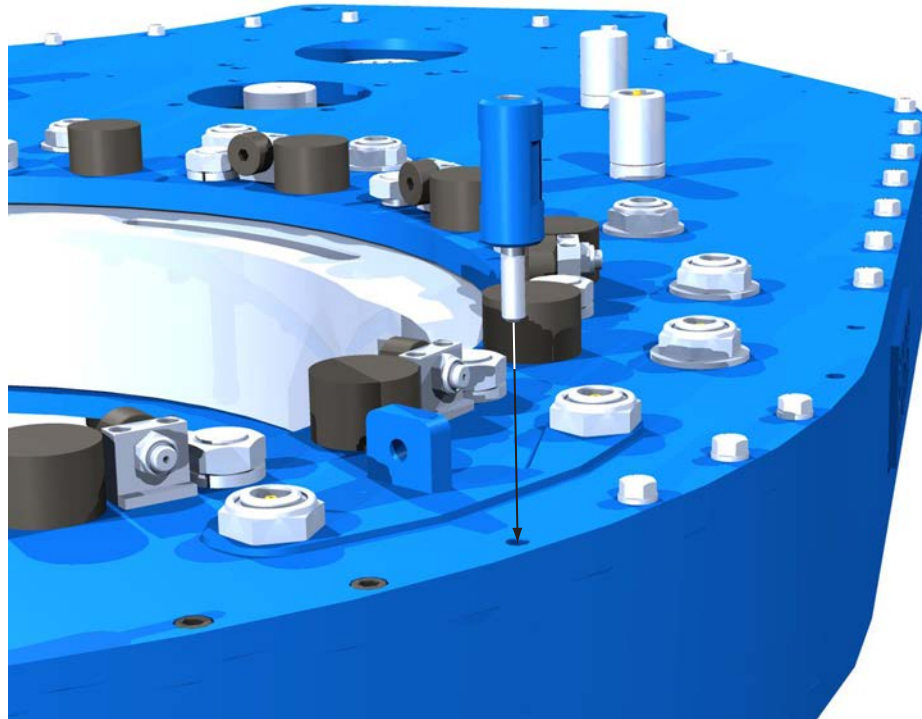
33. Connect the shifting handle weldment to the shifting shaft using two shifting links (PN 02-0120) and two  $\frac{5}{16}$ " x 1- $\frac{1}{2}$ " clevis pins. Secure the clevis pins with small hitch pins.
34. Insert the shifter detent ball (PN 02-0018) into the detent tube on the top shifter bushing. Insert the shifter detent spring (PN 997-0-64) into the detent tube. Thread a  $\frac{7}{16}$ " UNF jam nut on to the  $\frac{7}{16}$ " UNF x 1- $\frac{1}{4}$ " hex bolt, and then thread the bolt into the end of the detent tube. Lock the bolt to the detent tube with the hex nut. See Section 3.F.4 for shifter detent force tension adjustment instructions.
35. Position the top cage plate (PN 101-1580) on the top plate of the tong over the previously installed cam followers.
36. Position the bottom cage plate (PN 1037-D-51) against the bottom plate of the tong over the previously installed cam followers, and support until it is attached to the top cage plate. Secure the bottom cage plate to the top cage plate using two 1" UNC x 8" hex bolts and the rear cage plate bolt (PN 1037-36). Do not neglect to install the three cage plate spacers (PN 1037-C-38) between the top and bottom cage plates.

**ILLUSTRATION 3.I.7: TOP & BOTTOM CAGE PLATE INSTALLATION**

37. Press the four door pivot shoulder bushings (PN 101-0110) into the RH door weldment (PN 101-1703) and the LH door weldment (PN 101-1697). The bushings are installed so that the shoulders are towards the inside of the weldments.
38. Install latch weldment (PN 101-1570) onto RH door assembly (see Pp. 5.38 - 5.39). Install two latch springs between the latch weldment and the door weldment, and secure latch to RH door using the door latch shaft (PN 1037-C-200) and two latch cam plates (PN 1037-C-151). Secure each latch cam plate to the top and bottom door plates with one  $\frac{3}{8}$ " UNC x 1- $\frac{1}{4}$ " hex bolt and  $\frac{3}{8}$ " lock washer.
39. If not already done install the door pivot roller components that fit between the two body plates, i.e. everything except the roller shafts, nuts, washers, and door stop spacers.
40. Install the threaded door spring cylinder posts (101-0446), one on each side of the top plate, adjacent to the brake band lug weldments on the top plate (see illustration 3.I.8 next page)



## 3.1 ASSEMBLY PROCEDURES (CONTINUED):

**ILLUSTRATION 3.1.8: DOOR SPRING CYLINDER POST INSTALLATION**

41. Thread two  $\frac{1}{2}$ " UNC x  $1\frac{1}{4}$ " hex socket head set screws into each door assembly. Thread far enough through the door weldments that a  $\frac{1}{2}$ " jam nut can be threaded on to each set screw from the inside of the door assemblies.
42. Slide a  $1\frac{1}{8}$ " wide flat washer on to each door pivot roller shaft (PN 101-3940). Position the RH door assembly in its proper location, and insert a door pivot shaft from the top through the door assembly and the support roller components. Secure the door pivot shaft on the bottom using a 1" wide flat washer and 1" UNS thin nylock nut. Repeat the installation procedure for the LH door assembly.
43. Install the door spring cylinders (PN 1037-A4-144) using  $\frac{5}{8}$ " x  $\frac{3}{4}$ " UNC hex socket head shoulder bolts.



Ensure the guards on door spring cylinders extend over the top of the support rollers rather than toward the edge of the tong.

44. Install top and bottom lined brake band weldments (PN 1037-D-63). Fasten each brake band weldment to the top and bottom body plates with two brake band retainers (PN 101-1631), securing each retainer with two  $\frac{3}{8}$ " UNC x 1" hex bolts and  $\frac{3}{8}$ " lock washers. Fasten the ends of the brake bands to the brake band lug weldments using two  $\frac{3}{8}$ " UNC x  $4\frac{1}{2}$ " adjustment bolts and  $\frac{3}{8}$ " UNC hex nylock nuts per brake band, one per side. Ensure that the adjustment spring (PN 08-9264) is installed between the head of the adjustment bolt and the tab on the brake band weldment (four locations - see Pp. 5.32-5.33).
45. Install the backing pin assembly:
  - i. Drop the backing pin (PN 1037-C-39A) into one of the two backing pin receiver holes in the top cage plate..
  - ii. Place the backing pin retainer (PN 1037-B-54) over the rear cage plate bolt and the backing pin: ASSEMBLY NOTE: Ensure the larger diameter hole in the retainer slides over the backing pin.
  - iii. Secure the backing pin retainer to the rear cage plate bolt using a  $\frac{3}{8}$ " UNC x  $\frac{3}{4}$ " hex bolt and regular  $\frac{3}{8}$ " flat washer.
  - iv. Thread the backing pin knob (PN 02-0017) on to the backing pin.
46. Install the safety door components:
  - i. Attach RH safety door latch plate (PN 101-0319) to the RH door weldment using two  $\frac{3}{8}$ " UNC x  $1\frac{1}{2}$ " hex bolts and lock washers and two  $\frac{3}{8}$ " UNC x  $1\frac{1}{2}$ " flat head countersunk cap screws.



CE-marked tongs only: Attach RH safety door latch plate (PN 101-0319) to the RH door weldment using two  $\frac{3}{8}$ " UNC x  $1\frac{1}{2}$ " wire-drilled hex bolts and lock washers and two  $\frac{3}{8}$ " UNC x  $1\frac{1}{2}$ " flat head countersunk cap screws.

**3.1 ASSEMBLY PROCEDURES (CONTINUED):**

46. Install the safety door components (continued):

- ii. Attach RH safety door latch block (PN AE13-302M) to the RH safety door latch plate using four  $\frac{3}{8}$ " UNC x  $\frac{3}{4}$ " hex bolts and  $\frac{3}{8}$ " lock washers.



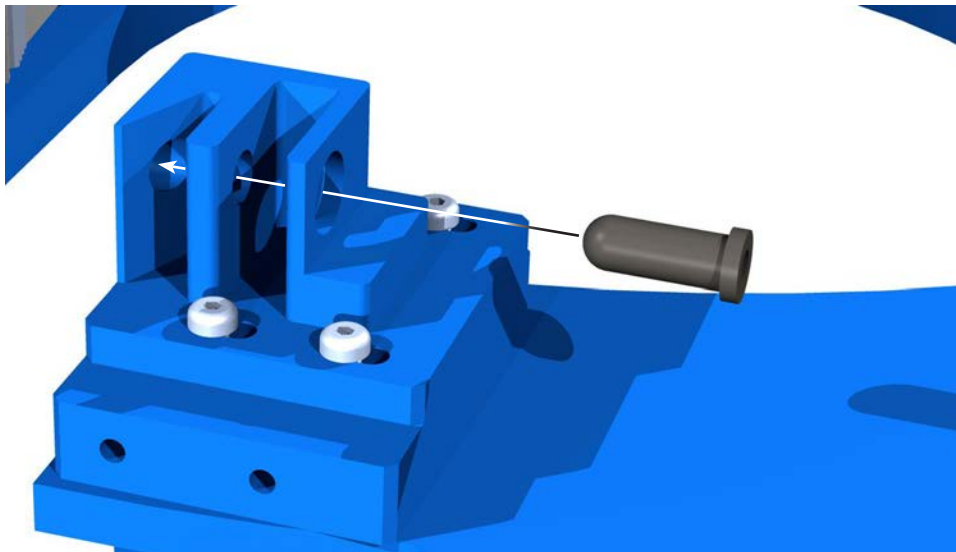
CE-marked tongs only: Attach RH safety door latch block (PN AE13-302M) to the RH safety door latch plate using four  $\frac{3}{8}$ " UNC x  $\frac{3}{4}$ " wire-drilled hex bolts and  $\frac{3}{8}$ " lock washers.

- iii. Attach LH safety door latch plate (PN 101-0915) to the LH door weldment using three  $\frac{3}{8}$ " UNC x 1- $\frac{1}{2}$ " flat head countersunk cap screws.
- iv. Attach LH safety door latch block (PN AE13-301S) to door latch plate # 2 (PN AE13-311) using three  $\frac{3}{8}$ " UNC x  $\frac{3}{4}$ " flat head countersunk cap screws.
- v. Attach LH safety door latch plate #2 to the LH safety door latch plate using four  $\frac{5}{16}$ " x  $\frac{3}{4}$ " UNC head socket shoulder screws.



CE-marked tongs only: Attach LH safety door latch plate #2 to the LH safety door latch plate using four  $\frac{5}{16}$ " x  $\frac{3}{4}$ " UNC socket head wire-drilled shoulder screws.

- vi. Insert load plunger (PN AE12-306) into LH safety door latch block.

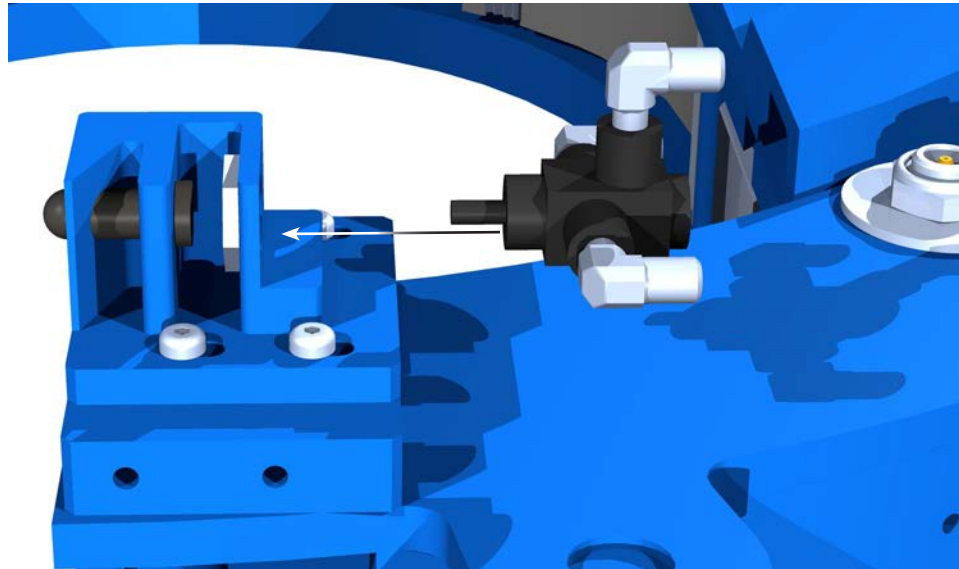


**ILLUSTRATION 3.1.9: SAFETY DOOR VALVE LOAD PLUNGER INSTALLATION**



**3.1 ASSEMBLY PROCEDURES (CONTINUED):**

46. Install the safety door components (continued):
- vii. Attach three ¼" NPT JIC elbows to the Deltrol safety door valve (PN 08-0337M). Position a 15/16" UNC valve lock nut as shown below, and secure the safety door valve to the LH safety door latch block using the valve lock nut.

**ILLUSTRATION 3.1.10: HYDRAULIC SAFETY DOOR SWITCH INSTALLATION**

- viii. Attach the safety door protector weldment (PN 101-0450) to the LH safety door latch plate using four 3/8" UNC x 1" hex bolts and lock washers. Note that the protector has a removable top plate (PN 101-1238) that is attached to the protector weldment using four 3/8" UNC x 3/4" hex bolts and lock washers.
47. Attach the hydraulic supports to the top plate:
- i. Attach the hydraulic valve mount weldments (PN 101-1442) to the top plate near the LH rotary idler, using one 3/8" UNC x 1" hex bolt and 3/8" lock washer per mount. ASSEMBLY NOTE: The "toes" on the valve mount weldments face toward the rear of the tong.
  - ii. Attach an L-shaped hydraulic line support weldment (PN 101-1138) to the top plate adjacent to the turns counter mounting location using two 3/8" UNC x 1" hex bolts and 3/8" lock washers.
  - iii. Attach the second L-shaped hydraulic line support weldment to the top plate adjacent to the RH pinion idler using two 3/8" UNC x 1" hex bolts, two 3/8" narrow washers, and two 3/8" UNC thin nylock nuts.
  - iv. Attach the adjustable support plate (PN 101-0022) to the hydraulic line support base installed in Step 47(ii) using two 3/8" UNC x 1" hex bolts, two 3/8" narrow washers, and two 3/8" UNC thin nylock nuts.
48. Attach four leg weldments (PN 997-D8-160A) to the bottom plate of the tong using 7/8" UNC x 1-1/2" hex bolts and 7/8" plain narrow flat washers.
49. Install tong hangers:
- i. Attach four tong hanger bracket weldments (PN 101-3985) to the bottom plate using 3/8" UNC x 2-1/2" hex bolts and 3/8" lock washers (2 each per weldment).
  - ii. Attach four tong hanger bracket bases (PN 101-4006) to the top plate using 3/8" UNC x 2-1/2" hex bolts and 3/8" lock washers (2 each per base).



CE-marked tongs only: secure hanger brackets and bases to the top and bottom plates using four 3/8" UNC x 2-1/2" wire-drilled hex bolts and 3/8" lock washers per set.



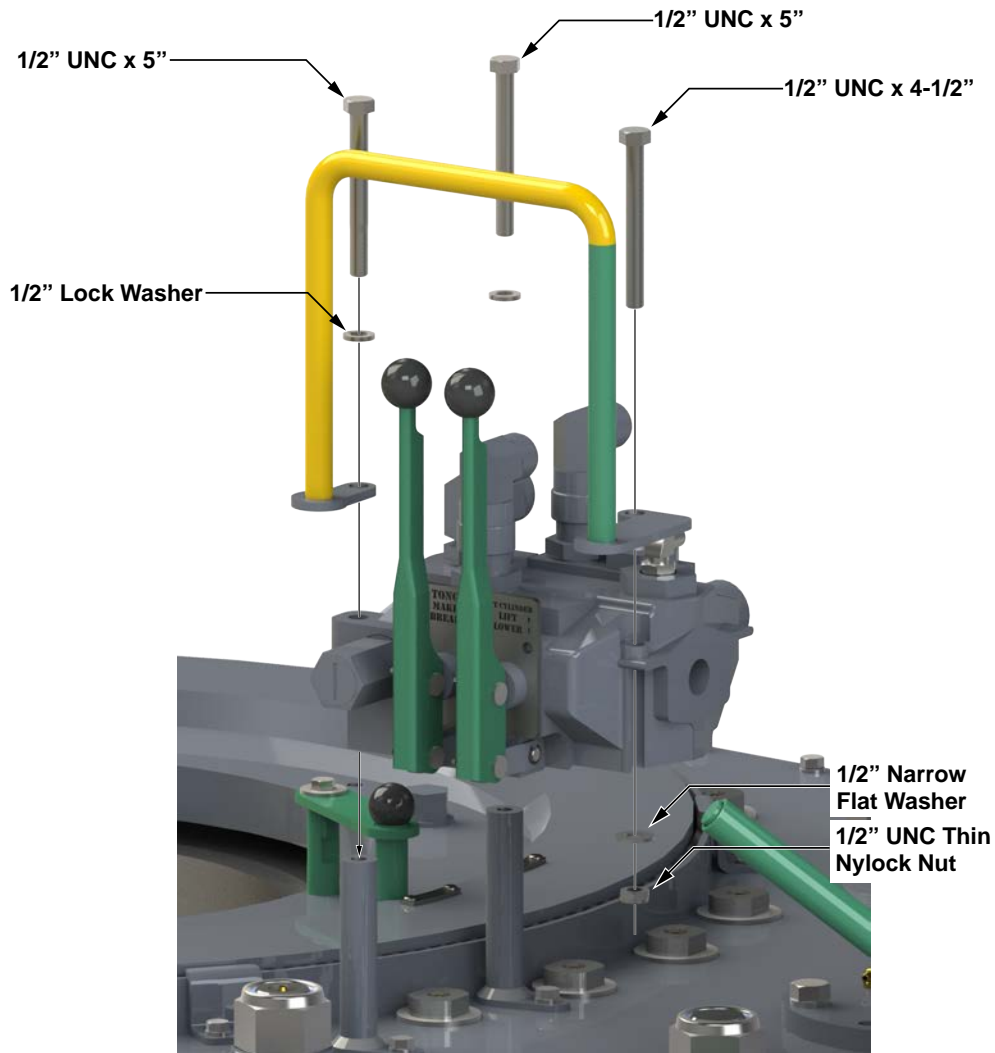
**DO NOT EXCEED THE SPECIFIED LENGTH OF ANY FASTENER (BOLTS, NUTS, CAP SCREWS, MACHINE SCREWS, ETC.).**

3.1 ASSEMBLY PROCEDURES (CONTINUED):

50. Use a crane and a temporary lifting sling to transport the hydraulic valve assembly to the top of the tong. Attach to the hydraulic valve support posts installed in step 47(i) using two 1/2" UNC x 4-1/2" hex bolts and 1/2" lock washers. Secure the inlet and outlet plumbing to the support assemblies installed in Step 47.



CE-marked tongs only: Install the valve handle guard weldment (PN CE-HANDLE-2) over the valve handles while securing the valve bank to the supports (see illustration 3.1.11).



**ILLUSTRATION 3.1.11: TONG ASSEMBLY - VALVE HANDLE GUARD INSTALLATION (CE MARKED TONGS)**

51. Use a crane to hoist the chain sling and maneuver the sling over the tong. Attach the chain sling to the four chain sling hangers using one shackle and bolt set (PN 02-9063) per hanger.
52. Attach torque gauge holder weldment (PN 101-4465) to the rear of the top plate behind the motor mount using two 3/8" UNC x 1" hex bolts and lock washers. Insert the torque gauge mount weldment (PN 1500-09-03A) into the holder weldment and secure with a 0.148" x 3" hitch pin.



**DO NOT EXCEED THE SPECIFIED LENGTH OF ANY FASTENER (BOLTS, NUTS, CAP SCREWS, MACHINE SCREWS, ETC.).**

## 3.J DAILY INSPECTION &amp; MAINTENANCE CHECKLIST

McCoy recommends that the following inspection and maintenance procedures be performed before each use, and at least once per day when the tong is in steady use, in the order in which they are listed.

1.  Rotate cage plate/rotary gear until the opening in the rotary gear faces towards the rear of the tong.



**DO NOT PERFORM ANY FURTHER ACTIONS OR MAINTENANCE WHILE THE TONG IS CONNECTED TO ANY HYDRAULIC POWER SUPPLY. FARR RECOMMENDS THAT ALL HYDRAULIC LINES ARE FULLY DISCONNECTED, AND RESIDUAL HYDRAULIC PRESSURE IS BLED OFF. ENSURE ADEQUATE CONTAINMENT IS IN PLACE TO PREVENT ENVIRONMENTAL CONTAMINATION FROM RESIDUAL HYDRAULIC FLUID.**

**DEPRESSURIZE HYDRAULIC SYSTEM IN PREPARATION FOR MAINTENANCE:**

2.
- 1) Rotate the tong to the "open throat" position. Ensure tong and backup doors (if equipped) are closed. Fully extend the lift cylinder
  - 2) De-energize the power unit.
  - 3) Repeatedly actuate the tong motor control valve lever IN BOTH DIRECTIONS to dissipate any residual pressure in the valve and motor.
  - 4) Remove the hydraulic SUPPLY line from the equipment.
  - 5) Repeatedly actuate the remaining control valve levers IN BOTH DIRECTIONS to dissipate any residual pressure in the remainder of the hydraulic control system.
  - 7) Disconnect the hydraulic RETURN line from the equipment.
  - 8) Disconnect remaining hoses such as case drains, or lines connected to the turns counter.



**HYDRAULIC PRESSURES AS HIGH AS OPERATING PRESSURE MAY REMAIN TRAPPED IN SMALL AREAS OF THE EQUIPMENT. ENSURE ALL MAINTENANCE IS CARRIED OUT BY A QUALIFIED SERVICE TECHNICIAN, AND THAT ADEQUATE PERSONAL PROTECTIVE EQUIPMENT IS USED TO GUARD AGAINST PRESSURE INJURIES**

3.  Perform an initial wash of the tong in order to remove the majority of dirt and grease build-up. Ensure adequate containment is in place to prevent environmental contamination from residual hydraulic fluid and dirty grease.
4.  Remove the access panel on the side of the tong directly adjacent to the shifter mechanism.
5.  Use a flashlight to perform a visual inspection of the gear train through the access panel and the opening of the rotary gear. If gear damage or chips of metal are seen, the tong should be removed from service and overhauled to avoid further damage. Replace access panel when inspection is complete.
6.  Perform a visual inspection of all fasteners and protruding body pieces (example: hydraulic valve mounts, inlet & outlet line supports, tong legs, shifter handle pivot lugs). Tighten or replace loose or missing fasteners. Farr recommends that damaged or missing body parts be repaired or replaced as soon as possible.
7.  Inspect the jaws and dies. Inspect the jaw roller pins for signs of damage - replace pins if necessary. If the pins are welded in place, replace the entire jaw assembly. Ensure dies are secure in the jaw - replace worn dies if necessary. Ensure that the jaw rollers rotate freely. Check to ensure the size of the loaded jaws match the size of casing or pipe you are running.
8.  Perform a visual inspection of all lifting points - if visible damage is seen, including cracks, broken lugs, distorted metal, etc. replace damaged part(s) before placing tong in service. Also inspect all chains, master links, and turnbuckles - again, if any damage is noted replace the damaged part(s) before placing the tong in service.
9.  Inspect tong for signs of premature wear, or moving parts that are rubbing (bare metal where there used to be paint is a good indication of wear).
10.  Inspect backing pin(s). If cracked, broken, or bent it (they) must be replaced.
11.  Inspect top and bottom brake band linings - replace if necessary. Unequal wear of the brake bands indicates that the brake band tension is not evenly adjusted. Refer to the maintenance section of the manual for instructions on properly adjusting brake bands.
12.  Perform a visual inspection of all hydraulic lines. Replace flexible lines if they appear to be cracked, fatigued, or have visible signs of wear from contact with a rigid object.
13.  Perform a visual inspection of all hydraulic lines. Replace flexible lines if they appear to be cracked, fatigued, or have visible signs of wear from contact with a rigid object.

14.  Perform a complete greasing of the tong - refer to Maintenance section of the technical manual
15.  Ensure main supply and return connections to the tong are fully made up. Re-connect the remainder of the hydraulic lines, and, if applicable, the electrical line to the turns counter.



**FAILURE TO ENSURE THAT THE SELF-SEALING SUPPLY AND RETURN LINES ARE FULLY MADE UP MAY RESULT IN CATASTROPHIC EQUIPMENT FAILURE.**

If using a stand-alone power unit, start it now - refer to the power unit technical manual for startup procedures. Listen to power unit for a moment to see if there are any unusual mechanical sounds (rubbing, grinding, excessive pump noise). If using a diesel unit, allow sufficient time for the engine to reach operating temperature before increasing engine RPM. Once engine is warm, gradually increase engine RPM until operating speed is reached.

16.  Ensure that supply pressure is at or above the tong's specified operating pressure, and that the return pressure is less than 350 psi.
17.  Perform a visual inspection of pressurized hydraulic lines. Document and correct any hydraulic fluid leaks.
18.  Perform a full functional test of the tong. Report and correct any hydraulic leaks from the hydraulic valve bank, or from any hydraulic cylinders that are used.
19.  Perform a visual inspection of the load cell. If using a tension load cell, replace any cracked, broken, or distorted components including links and chains. If using a compression load cell, replace any component that has been crushed or otherwise distorted through compression.
20.  If applicable, inspect the load cell anchor pins (tension load cell only). Replace the anchor pins if cracking or metal distortion is seen.
21.  Test safety door feature. See sub-section 2.H.5 for safety door testing procedures.



**NEVER OPERATE YOUR EQUIPMENT WITH A BYPASSED OR MALFUNCTIONING SAFETY DOOR**

23.  While rotating the cage plate, ensure that the jaws properly cam. If the jaws do not cam properly, the brake bands need to be tightened. Incrementally adjust both the top and bottom brake bands EQUALLY until proper cam action is achieved (see sub-section 3.F.1).



CE-marked tongs only: Inspect all wire-ties on drilled bolts on critical safety systems. All wiring must be intact and appear tamper-free. Check the integrity of all guards, including the rubber protective washers over the backup leg openings.

## 3.K MONTHLY MAINTENANCE CHECKLIST - POWER TONG

The following maintenance checklist is intended as a guideline rather than a definitive maintenance schedule. Your equipment may require more, or less, maintenance depending upon the frequency of use, the percentage of maximum torque that your equipment is routinely subjected to, and the field conditions under which your equipment operates. McCoy recommends that the following inspection and maintenance procedures be performed monthly, or in conjunction with your maintenance foreman's experience and best estimate of when your equipment is due for this maintenance.

1.  Rotate cage plate/rotary gear until the opening in the rotary gear faces towards the rear of the tong.



**DO NOT PERFORM ANY FURTHER ACTIONS OR MAINTENANCE WHILE THE TONG IS CONNECTED TO ANY HYDRAULIC POWER SUPPLY. MCCOY RECOMMENDS THAT ALL HYDRAULIC LINES ARE FULLY DISCONNECTED, AND RESIDUAL HYDRAULIC PRESSURE IS BLED OFF. ENSURE ADEQUATE CONTAINMENT IS IN PLACE TO PREVENT ENVIRONMENTAL CONTAMINATION FROM RESIDUAL HYDRAULIC FLUID.**

DEPRESSURIZE HYDRAULIC SYSTEM IN PREPARATION FOR MAINTENANCE:

- 1) De-energize the power unit.
- 2) Repeatedly actuate the tong motor control valve lever IN BOTH DIRECTIONS to dissipate any residual pressure in the valve and motor.
2.  3) Remove the hydraulic SUPPLY line from the equipment.
- 4) Repeatedly actuate the remaining control valve levers IN BOTH DIRECTIONS to dissipate any residual pressure in the remainder of the hydraulic control system.
- 5) Disconnect the hydraulic RETURN line from the equipment.
- 6) Disconnect remaining hoses such as case drains, or lines connected to the turns counter.



**HYDRAULIC PRESSURES AS HIGH AS OPERATING PRESSURE MAY REMAIN TRAPPED IN SMALL AREAS OF THE EQUIPMENT. ENSURE ALL MAINTENANCE IS CARRIED OUT BY A QUALIFIED SERVICE TECHNICIAN, AND THAT ADEQUATE PERSONAL PROTECTIVE EQUIPMENT IS USED TO GUARD AGAINST PRESSURE INJURIES**

3.  Clean the exterior of the tool thoroughly, using either water (if using a pressure washer ensure a low-pressure wash wand is used), or an appropriate solvent-based grease-cutting cleaner such as Varsol. Ensure adequate containment is in place to prevent environmental contamination from residual hydraulic fluid, dirty grease, and cleaning agents.
4.  Remove the access panel on the side of the tong directly adjacent to the shifter mechanism.
5.  Clean the interior of the tong thoroughly, using either water (do not use a pressure washer), or an appropriate solvent-based grease-cutting cleaner such as Varsol. Ensure adequate containment is in place to prevent environmental contamination from residual hydraulic fluid, dirty grease, and cleaning agents. Make a note if any metal shavings or metal pieces are flushed out of the gear train cavity - if shavings or metal pieces are seen the tong must be overhauled before it is returned to service.
6.  Inspect all fasteners and fastener safety wires (if equipped). Replace any missing fasteners - use Grade 8 bolts only unless otherwise specified. Re-torque all external fasteners to SAE specifications.
7.  Repair or replace any damaged or missing external body parts, such as torque gauge mounts, hydraulic supports, safety door protectors, etc.
8.  Perform a visual inspection of all fasteners and protruding body pieces (example: hydraulic valve mounts, inlet & outlet line supports, tong legs, shifter handle pivot lugs). Tighten or replace loose or missing fasteners.
9.  Inspect tong for signs of premature wear, or moving parts that are rubbing (bare metal where there used to be paint is a good indication of wear.
10.  Inspect all paint - locations in which the paint has been damaged must be repaired prior to the tong being returned to service. Prepare areas to be painted to ensure they are free of grease, dirt, or solvent. Touch up using a solvent-based acrylic paint - "McCoy Grey" is paint color number RAL7015, "McCoy Yellow" (hazard areas) is RAL1007, and McCoy Green is RAL6029 (contact McCoy sales for paint number for custom paint applications). Allow sufficient time for paint to dry before proceeding.
11.  Visually inspect all load-bearing welds. Any weld that is cracked or separating must be repaired and repainted before returning the tong to service.

12.  Perform a visual inspection of all lifting points - if visible damage is seen, including cracks, broken lugs, distorted metal, etc. replace damaged part(s) before placing tong in service. Also inspect all chains, master links, and turnbuckles - again, if any damage is noted replace the damaged part(s) before placing the tong in service. Refer to Section 2A of the technical manual (Sling/Load Bearing Device Safety) for information on recommended testing and recertification. Please note that turnbuckles with part number 101-3086 (short turnbuckles) use a high-strength pin which must be supplied by McCoy Global.



**“SHORT” TURNBUCKLES HAVING PART NUMBER 101-3086 EMPLOY HIGH-STRENGTH PINS WHICH MUST BE SUPPLIED BY MCCOY.**

13.  Remove hydraulic motor and rotate the gear train by hand, and use a flashlight to perform a visual inspection of the gear train through the access panel and the opening of the rotary gear while the gear train is being rotated. If gear damage or chips of metal are seen, the tong should be removed from service and overhauled to avoid further damage. Replace access panel when inspection is complete.
14.  Inspect all jaws and dies in use for the maintenance interval. Remove pin & roller, and inspect for signs of damage - replace pins if necessary. If the pins are welded in place & the welds are found to be damaged, remove and quarantine the jaw until the weld is repaired. Clean the pins and rollers, and reassemble using a liberal coating of anti-seize compound. Ensure dies are secure in the jaw & die retainers are present. Replace worn dies if necessary. Ensure that the jaw rollers rotate freely.
15.  Inspect backing pin(s). If cracked, broken, or bent it (they) must be replaced.
16.  Inspect top and bottom brake band linings - replace if lining is found to be flaking or is missing pieces of material. Unequal wear of the brake bands indicates that the brake band tension is not evenly adjusted. Refer to the maintenance section of the manual for instructions on properly adjusting brake bands.
17.  Inspect door springs. Ensure the springs retain sufficient strength to be able to assist the opening of the door, and to keep the door open. The springs should also help to “snap” the door shut.
18.  Inspect backup springs (if applicable). The rear extension springs (where used) should be equally extended, and the front leg springs should be equally compressed. Ensure that neither of the rear backup springs have been over-extended and lack sufficient tension to adequately support the backup. Ensure that neither of the front leg springs (or, when installed, the single rear backup leg spring) have been over-compressed, and still retain enough spring strength to support the front of the backup.
19.  Extend all hydraulic cylinders, and inspect cylinder rods for signs of mechanical damage, flaking, or rust. McCoy recommends that damaged cylinders be replaced prior to storage.
20.  Perform a visual inspection of all hydraulic lines. Replace flexible lines if they appear to be cracked, fatigued, or have visible signs of wear from contact with a rigid object. If your tong is equipped with rigid hydraulic lines, replace any line that is dented or appears to be stressed or cracked.
21.  Generously fill the gear train housing with grease through the access panel, and also through the opening in the rotary gear. Perform a full lubrication - refer to Maintenance section of manual to determine lubrication points.
22.  Ensure main supply and return connections to the tong are fully made up. Re-connect the remainder of the hydraulic lines.



**FAILURE TO ENSURE THAT THE SELF-SEALING SUPPLY AND RETURN LINES ARE FULLY MADE UP MAY RESULT IN CATASTROPHIC EQUIPMENT FAILURE.**

If using a stand-alone power unit, start it now - refer to the power unit technical manual for startup procedures. Listen to power unit for a moment to see if there are any unusual mechanical sounds (rubbing, grinding, excessive pump noise). If using a diesel unit, allow sufficient time for the engine to reach operating temperature before increasing engine RPM. Once engine is warm, gradually increase engine RPM until operating speed is reached.

23.  Ensure that supply pressure is at or above the tong’s specified operating pressure, and that the return pressure is less than 350 psi.
24.  Perform a visual inspection of pressurized hydraulic lines. If any hydraulic fittings or hoses are leaking they must be repaired or replaced before proceeding.
25.  Rotate tong for one minute in both high and low gear. Stop the tong and reverse the direction of rotation for another minute in both high and low gear, ending with the opening of the rotary gear facing the gear train. De-energize the power unit, and perform another generous lubrication of the gear train, including the gear housing.
26.  Energize power unit. Rotate tong for one minute in both high and low gear. Stop the tong and reverse the direction of rotation for another minute in both high and low gear, ending with the opening of the rotary gear facing the gear train.
27.  De-energize the power unit, and perform a third generous lubrication of the gear train, including the gear housing.



28.  Rotate tong in low gear for 5 minutes while monitoring pressurized seals and hydraulic lines. If a seal, line, or fitting begins to leak while tong is rotating, it must be replaced before the equipment is returned to service.
29.  Rotate tong in high gear for 5 minutes while monitoring temperature of top and bottom bearing caps. If the bearing caps are hot to the touch (higher than approximately 50°C) replace the applicable bearings. Likewise if the tong is making unusual noises check for damaged bearings (see Maintenance Manual for all bearing locations).
30.  Install load cell. If using a tension load cell, perform a visual inspection and replace any cracked, broken, or distorted components including links and chains. If using a compression load cell, replace any component that has been crushed or otherwise distorted through compression. Inspect load cell for damage or signs of stress. Check oil level in load cell and fill if necessary (refer to technical manual Section 7 or Section 8).
31.  If applicable, inspect the load cell anchor pins (tension load cell only). Replace the anchor pins if cracking or metal distortion is seen.
32.  If applicable, the weld securing the single load cell anchor to the bridge bar main plate must be inspected (compression load cell only). If the integrity of the weld has been compromised, the tong must be removed from service until the weld is repaired. The load cell beam will need to be disconnected and removed so the weld is visible. Before re-installing the beam, liberally grease the anchor pin before reinserting into the load cell beam.
33.  While rotating the cage plate, ensure that the jaws properly cam. If the jaws do not cam properly, the brake bands need to be tightened. Incrementally adjust both the top and bottom brake bands EQUALLY until proper cam action is achieved. Refer to the maintenance section of the manual for instructions on properly adjusting brake bands.
34.  Perform a full functional test of the tong (refer to Section 2.H.5). Report and correct any hydraulic leaks from the hydraulic valve bank, or from any hydraulic cylinders that are used.
35.  Test safety door feature. See sub-section 2.H.5 for safety door testing procedures.



**NEVER OPERATE YOUR EQUIPMENT WITH A BYPASSED OR MALFUNCTIONING SAFETY DOOR**

36.  McCoy recommends that an anti-corrosive agent such as Tectyl® 506 be applied to all external unpainted surfaces (and chain slings) EXCEPT cylinder rods, jaw rollers, and rotary gear camming surfaces. Refer to manufacturer data sheets for proper application and safety information.

**Once all of the above maintenance checklist items have been satisfactorily completed the tool may be returned to service.**

**3.L. TUBULAR CONNECTION EQUIPMENT DE-COMMISSIONING & SHIPPING PROCEDURE**

Perform the following decommissioning procedures when removing tubular connection equipment from service, with the intent of short to long-term storage. These procedures are essential for ensuring proper protection of the equipment from environmental attack, and to aid in the quick turnaround when returning the equipment to service.

Store all o-rings, seals, packings, gaskets, etc. in strong moisture proof, airtight containers. Ensure that these items are not crushed, nicked, or otherwise damaged.

Do not perform any further actions or maintenance while the tong is connected to any hydraulic power supply. McCoy recommends that all hydraulic lines are fully disconnected, and residual hydraulic pressure is bled off. Ensure adequate containment is in place to prevent environmental contamination from residual hydraulic fluid.



**IN ORDER TO MAINTAIN THE INTEGRITY OF INSTALLED SEALS, MCCOY RECOMMENDS THAT THE MAXIMUM STORAGE INTERVAL NOT EXCEED ONE YEAR. AT LEAST ONCE PER YEAR ALL TUBULAR CONNECTION IN LONG-TERM STORAGE SHOULD BE RECOMMISSIONED AS PER SECTION 3.M. IF FURTHER STORAGE IS REQUIRED, THE EQUIPMENT SHOULD THEN BE PUT THROUGH ANOTHER DE-COMMISSIONING PROCEDURE.**

**DEPRESSURIZATION PROCEDURE IN PREPARATION FOR STORAGE:**

- 1) Rotate the tong so that the opening in the rotary gear faces the gear train (towards the rear of the tong). Ensure tong and backup doors (if equipped) are closed. Fully extend the lift cylinder (if equipped). If mounted in a frame, retract the float cylinders (if equipped).
- 2) De-energize the power unit.
- 3) Repeatedly actuate the tong motor control valve lever IN BOTH DIRECTIONS to dissipate any residual pressure in the valve and motor.
- 4) Remove the hydraulic SUPPLY line from the equipment.
- 5) Repeatedly actuate the remaining control valve levers IN BOTH DIRECTIONS to dissipate any residual pressure in the remainder of the hydraulic control system.
- 7) Disconnect the hydraulic RETURN line from the equipment.
- 8) Disconnect remaining hoses such as case drains, or lines connected to the turns counter.



**HYDRAULIC PRESSURES AS HIGH AS OPERATING PRESSURE MAY REMAIN TRAPPED IN SMALL AREAS OF THE EQUIPMENT. ENSURE ALL MAINTENANCE IS CARRIED OUT BY A QUALIFIED SERVICE TECHNICIAN, AND THAT ADEQUATE PERSONAL PROTECTIVE EQUIPMENT IS USED TO GUARD AGAINST PRESSURE INJURIES**

1.  Perform an initial wash of the tool in order to remove the majority of dirt and grease build-up. Ensure adequate containment is in place to prevent environmental contamination from residual hydraulic fluid and dirty grease.
2.  Remove the access panel on the side of the tong directly adjacent to the shifter mechanism.
3.  Clean the interior of the tong thoroughly, using either water (do not use a pressure washer), or an appropriate solvent-based grease-cutting cleaner such as Varsol. Ensure adequate containment is in place to prevent environmental contamination from residual hydraulic fluid, dirty grease, and cleaning agents. Make a note if any metal shavings or metal pieces are flushed out of the gear train cavity - if shavings or metal pieces are seen the tong must be overhauled before it is returned to service.
4.  Clean the exterior of the tool thoroughly, using either water (do not use a pressure washer), or an appropriate solvent-based grease-cutting cleaner such as Varsol. Ensure adequate containment is in place to prevent environmental contamination from residual hydraulic fluid, dirty grease, and cleaning agents.
5.  Inspect all fasteners and fastener safety wires. Replace any missing fasteners - use Grade 8 bolts only. Re-torque all external fasteners to SAE specifications.
6.  Inspect backing pin(s). If cracked, broken, or bent it (they) must be replaced.
7.  Repair or replace any damaged or missing external body parts, such as torque gauge mounts, hydraulic supports, safety door protectors, etc.
8.  Inspect all paint - locations in which the paint has been damaged must be repaired prior to storage. Prepare areas to be painted to ensure they are free of grease, dirt, or solvent. Touch up using a solvent-based acrylic paint - "Farr Blue" is paint number RAL.5005. Allow sufficient time for paint to dry before proceeding.
9.  Perform a liberal lubrication of the equipment - refer to Maintenance section of manual to determine lubrication points. Generously fill the gear train housing with grease through the access panel, and also through the opening in the rotary gear.
10.  Connect the equipment to a hydraulic power unit. Ensure all lines are fully made up to prevent equipment damage from excessive back pressure. Do not neglect to connect the motor drain.
11.  Energize power unit.

12.  Rotate tong for one minute, stop, and reverse the direction of rotation for another minute, ending with the opening of the rotary gear facing the gear train. De-energize the power unit, and perform another generous lubrication of the gear train, including the gear housing.
13.  Energize power unit. Rotate tong for one minute, stop, and reverse the direction of rotation for another minute, ending with the opening of the rotary gear facing the gear train.
14.  De-energize the power unit, and perform a third generous lubrication of the gear train, including the gear housing.
15.  Energize power unit, and rotate the tong for a final time, one minute in one direction, stop, and reverse the direction of rotation for another minute, this time ending with the rotary gear in the "open throat" position.
16.  Extend all hydraulic cylinders, and inspect cylinder rods for signs of mechanical damage, flaking, or rust. McCoy Global recommends that damaged cylinders be replaced prior to storage.
17.  If you are using a frame-mounted tool, the tong must be lowered onto the backup in order to remove the risk of sudden and catastrophic movement when pressure is removed from the float cylinders. Cover the top of the backup with protective cloth to protect the paint on the backup. Place two wooden beams across the top of the tong, ensuring that the beams have a minimum size of 4" x 4" x the width of the tong. Cover the tops of the wooden beams with more protective cloth to prevent paint damage to the tong. When lowering the tong onto the beams, ensure that the beams come into flat contact with the bottom of the tong, away from bearing caps, brake bands, or other protrusions on the bottom of the tong. Ensure that the tong hanger chains are loose, but not dangling into contact with the hangers or top plate of the tong.

**Depressurization Procedure For Storage:**

- 1) Rotate the tong to the "open throat" position.
  - 2) Exercise each hydraulic cylinder several times - open the tong and backup doors (if equipped), retract and extend the remote backing pin ramp (if equipped), retract and extend the float cylinders. Leave all cylinders except for the door cylinders in their fully retracted position. The general idea is to have as little of the chrome cylinder rods exposed as possible.
  - 3) De-energize the power unit.
  - 4) Repeatedly actuate the tong motor control valve lever IN BOTH DIRECTIONS to dissipate any residual pressure in the valve and motor.
  - 5) Remove the hydraulic SUPPLY line from the equipment.
  - 6) Repeatedly actuate the remaining control valve levers IN BOTH DIRECTIONS to dissipate any residual pressure in the remainder of the hydraulic control system.
  - 7) Connect a low-pressure air supply line (10 PSI or less) to the hydraulic supply line, and force a small amount of the remaining hydraulic fluid from the valve assembly - this will allow for thermal expansion of the hydraulic fluid if the equipment is stored or transported in high ambient temperatures. Failure to do this may result in damaged or destroyed seals in the equipment.
  - 8) Disconnect the hydraulic RETURN line from the equipment.
  - 9) Disconnect remaining hoses such as case drains, or lines connected to the turns counter.
18.  If any hydraulic fittings or hoses are leaking they must be repaired or replaced before proceeding.
19.  Wipe all excess grease from outside of equipment. Replace the access door panel. Use a solvent-based cleaner on rags to wipe all external surfaces to remove residual grease or hydraulic fluid. Once the outside surfaces have been de-greased, wipe all external surfaces with clean water to remove residual solvent.
20.  McCoy Global recommends that chain slings be removed and stored separately. Rigid slings and other rigid suspension devices may remain in place.
21.  Apply grease or heavy oil to all exposed cylinder rods.
22.  McCoy Global recommends that an anti-corrosive agent such as Tectyl<sup>®</sup> 506 be applied to all external surfaces EXCEPT cylinder rods (including chain slings). Refer to manufacturer data sheets for proper application and safety information.



**DO NOT ALLOW ANTI-CORROSIVE AGENTS TO CONTACT CYLINDER RODS. CYLINDER ROD DAMAGE WILL OCCUR.**

23.  Allow the anti-corrosive coating ample time to dry - refer to manufacturer data sheets for drying times at room temperature.
24.  Wrap entire assembly in 100 gauge (1 mil) corrosion-inhibiting wrap, at least 3 layers thick. Attempt to ensure that the tool is well-sealed within the wrapping, including the bottom.

If possible, store in a sealed, climate controlled environment. If isolated storage is not available, McCoy recommends storing your wrapped equipment in a secure, out-of-the-way location, using silica gel desiccant to reduce the humidity within the wrapping. As a guideline, use 125 g. of desiccant for each cubic metre of space, or 3.5 g. per cubic foot.

#### Calculation Of Required Desiccant:

- 1) Calculate the trapped air volume by measuring the outside dimensions of the tool to be stored, and treat that as the volume to be stored. For example, the external dimensions of a KT20000 20" power tong are 80.25" x 50.5" x 28", which calculates to an approximate volume of 113500 in<sup>3</sup>, or 66 ft<sup>3</sup> (1.87 m<sup>3</sup>).
- 2) Multiply the calculated air volume, in cubic feet, by the recommended amount of desiccant per cubic foot. Carrying forth the example used in the previous step, the required desiccant charge would be 3.5 g. x 66 ft<sup>3</sup>, equaling 231 g. Several manufacturers offer silica gel desiccant in packaged quantities of 125 grams per bag, so two packages of desiccant would be required. Please keep in mind that this is a guideline only - more or less desiccant may be required in extreme environmental conditions.

For best corrosion resistance the equipment should be removed from storage and exercised on a regular basis, depending on the storage environment. McCoy recommends that for equipment stored in a salt-water maritime or exposed dusty environment, repeat steps 9 through 24 monthly. For equipment stored in isolated storage in a non-maritime environment, repeat steps 9 through 24 quarterly. Replace desiccant packs at this time - depleted desiccant packs may be treated as regular dunnage.

#### Shipping Instructions:

The following procedure lists the steps to be followed to prepare your tong for shipping.

1. If not already done remove accessories (tong jaws, load cell, torque gauge, etc.) McCoy recommends wrapping these items in protective wrap and placing in a separate wooden crate.
2. Place the equipment on a sturdy pallet constructed of 4" x 4" cross-members and 2" x 4" flooring. McCoy recommends placing a 2" x 6" board across the width of the tong under the legs (see Illustration 3.M.1). Ensure the pallet is large enough to accommodate the wooden crate containing the tong accessories.

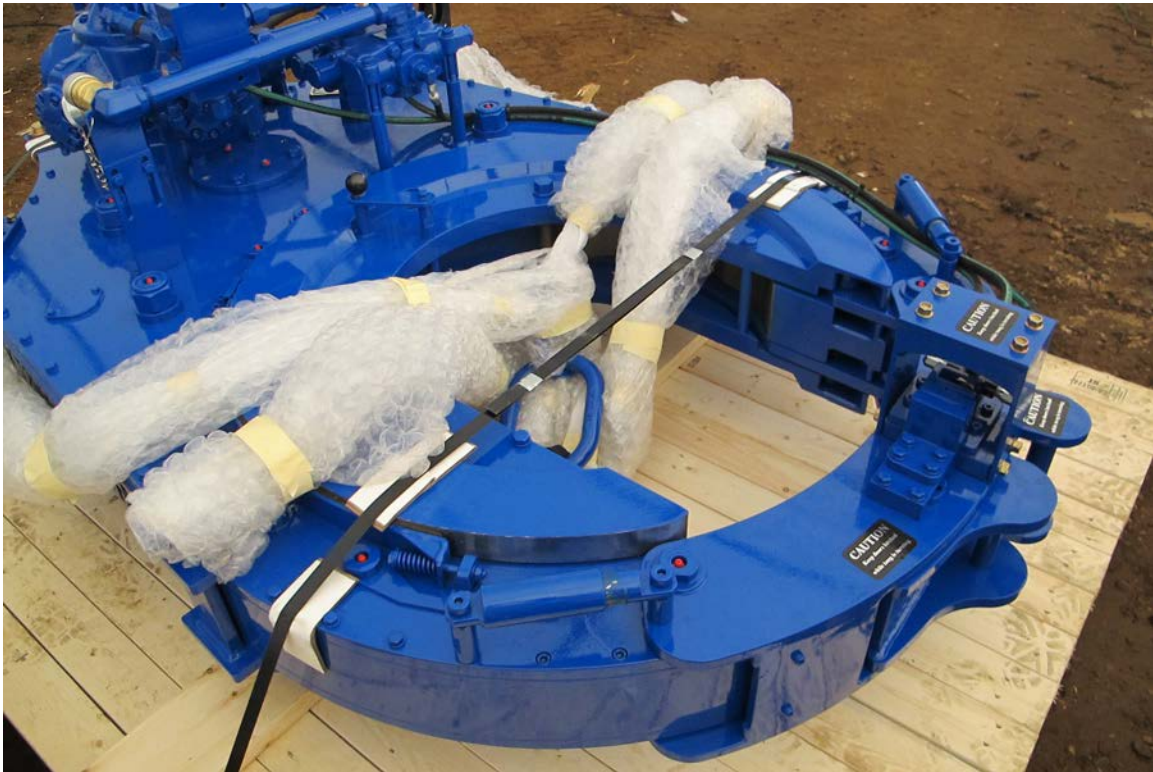


**ILLUSTRATION 3.L.1: SHIPPING INSTRUCTIONS - PALLET**



**Shipping Instructions (Continued):**

3. Use a crane to support the chain sling (if equipped). Wrap the chain sling with bubble wrap or another similar protective wrapping, and secure the wrapping with tape. Lower the wrapped chain sling so it sits inside the opening of the tong.



**ILLUSTRATION 3.L.2: SHIPPING INSTRUCTIONS - WRAPPING CHAIN SLING & STRAPPING TO PALLET**

4. Securely strap the equipment in place using metal strapping (see Illustration 3.L.2). Place strapping as close to the cross-members under the equipment legs as possible, and use caution not to entrap any flexible hydraulic hoses beneath the strapping (guide strapping through beneath the hydraulic hoses). Use the following guidelines to determine the strapping requirements:

Assemblies weighing 1000 lbs (454 kg) or less:

$\frac{3}{4}$ " x 0.029" metal strapping, 3320 lbs (1509 kg) tensile strength  
Minimum two straps

Assemblies weighing more than 1000 lbs (454 kg) or less:

1- $\frac{1}{4}$ " x 0.031" metal strapping, 5500 lbs (2500 kg) tensile strength  
Minimum two straps for assemblies weighing less than 5000 lbs (2273 kg)  
Minimum three straps for assemblies weighing more than 5000 lbs (2273 kg)

Before tightening strapping, place strapping protectors wherever the metal strapping comes into contact with the equipment.

Place the wooden crate containing the tong accessories on the crate next to the equipment. Strap the crate to the pallet using  $\frac{3}{4}$ " x 0.029" metal strapping. If it is not practical to place larger loose items in a wooden crate, ensure they are also securely strapped to the pallet using  $\frac{3}{4}$ " x 0.029" metal strapping.

5. Use a large polyethylene shipping bag (sometimes called a pallet cover) to completely enclose the equipment. Seal polyethylene bag to the pallet using 1 mil polyethylene wrap. Use the wrap to conform the plastic cover to the general shape of the equipment, but do not wrap so tight that sharp edges on the equipment perforate the cover.
6. McCoy recommends enclosing the equipment in a sturdy shipping crate which is securely fastened to the pallet.

**3.M TUBULAR CONNECTION EQUIPMENT RE-COMMISSIONING PROCEDURE**

Perform the following recommissioning procedures when removing tubular connection equipment from short or long-term storage back into regular service. These procedures are essential for ensuring proper equipment preparation and operation. The following procedures also assume that the decommissioning and storage procedures recommended by McCoy Global have been strictly observed.

1.  Remove all protective plastic wrapping. If there are desiccant packs with the assembly, they may be disposed of with the regular garbage.
2.  Remove the access panel on the side of the tong directly adjacent to the shifter mechanism.
3.  Wipe excess grease or heavy oil from exposed cylinder rods.
4.  If applicable, re-connect chain sling to lifting lugs. Perform a visual inspection of all lifting points - if visible damage is seen, including cracks, broken lugs, distorted metal, etc. replace damaged part(s) before placing tong in service. Also inspect all chains, master links, and turnbuckles - again, if any damage is noted replace the damaged part(s) before placing the tong in service. If your company requires yearly certification of lifting equipment, ensure that the most recent test date falls within the past year. Perform recertification if necessary.
5.  Perform a liberal lubrication of the equipment - refer to Maintenance section of manual to determine lubrication points. Generously fill the gear train housing with grease through the access panel, and also through the opening in the rotary gear.
6.  Connect the equipment to a hydraulic power unit. Ensure all lines are fully made up to prevent equipment damage from excessive back pressure. Do not neglect to connect the motor drain.



**FAILURE TO ENSURE THAT THE SELF-SEALING SUPPLY AND RETURN LINES ARE FULLY MADE UP MAY RESULT IN CATASTROPHIC EQUIPMENT FAILURE.**

7.  Energize power unit.
8.  Ensure that supply pressure is at or above the tong's specified operating pressure, and that the return pressure is less than 350 psi.
9.  Perform a thorough inspection of pressurized hydraulic lines and fittings. Any leaking hydraulic fluid lines or fittings must be replaced before the equipment is returned to service.
10.  Perform a thorough inspection of all seals. Any seal that is leaking or "weeping" must be replaced before the equipment is returned to service.
11.  Rotate tong in low gear for 5 minutes while monitoring pressurized seals and hydraulic lines. If a seal, line, or fitting begins to leak while tong is rotating, it must be replaced before the equipment is returned to service. Finish this step with the rotary gear opening facing the gear train. De-energize the power unit.
12.  Inspect all flexible hydraulic lines for signs of wear, blistering, or any other signs of potential failure - replace if signs of potential failure are identified.
13.  Inspect the gear train housing. If the amount of grease is inadequate, liberally grease the gear train through the access panel, and through the opening in the rotary gear.
14.  Inspect top and bottom brake band linings - replace if necessary. Unequal wear of the brake bands indicates that the brake band tension is not evenly adjusted. Refer to the maintenance section of the manual for instructions on properly adjusting brake bands. Ensure that all grease is wiped from brake band linings and the parts of the cage plates that come into contact with the brake band linings.
15.  Re-install access panel. Install a set of pre-inspected jaws that are the correct size for the pipe or casing being run.
16.  Install load cell. If using a tension load cell, perform a visual inspection and replace any cracked, broken, or distorted components including links and chains. If using a compression load cell, replace any component that has been crushed or otherwise distorted through compression.
17.  If applicable, inspect the load cell anchor pins (tension load cell only). Replace the anchor pins if cracking or metal distortion is seen.
18.  If applicable, the weld securing the single load cell anchor to the bridge bar main plate must be inspected (compression load cell only). If the integrity of the weld has been compromised, the tong must be removed from service until the weld is repaired. The load cell beam will need to be disconnected and removed so the weld is visible. Before re-installing the beam, liberally grease the anchor pin before reinserting into the load cell beam.
19.  Re-energize power unit.



20.  Perform a full functional test of the equipment including, if applicable, backup components and float frame components. Report and correct any hydraulic leaks from the hydraulic valve bank, or from any hydraulic cylinders that are used.
21.  If using a frame-mounted tong and backup system, raise the tong off the beams that it is resting upon. Remove the beams and protective cloths - inspect the paint on top of the backup and the bottom of the tong to ensure it has not been damaged by the beam.
22.  Test safety door feature. See sub-section 2.H.5 for safety door testing procedures.



**NEVER OPERATE YOUR EQUIPMENT WITH A BYPASSED OR MALFUNCTIONING SAFETY DOOR**

23.  While rotating the cage plate, ensure that the jaws properly cam. If the jaws do not cam properly, the brake bands need to be tightened. Incrementally adjust both the top and bottom brake bands EQUALLY until proper cam action is achieved.
24.  When all of the previous steps are completed, you may return your re-commissioned equipment to service.



**This page intentionally  
left blank**



SECTION 4: TROUBLESHOOTING



**This page intentionally  
left blank**

Adequate maintenance and proper fluid selection is essential for minimizing hydraulic-related failures. All troubleshooting must be performed by a technician trained in hydraulic systems, and familiar with the equipment design, assembly and operation.

The following troubleshooting instructions are intended to be guidelines only. Any faults not solved through the use of this guide should be referred to our engineering department for their evaluation and recommendations.

**4.A TONG WILL NOT DEVELOP SUFFICIENT TORQUE**

	POSSIBLE PROBLEM	SOLUTION(S)
1	Malfunctioning relief valve on tong hydraulic circuit	See Section 4.B, Relief Valve Troubleshooting
2	Directional valve is leaking	Check directional valve. Neutral position should return fluid directly to the reservoir. Replace or repair valve to ensure correct operation
3	Power unit is not producing adequate pressure	Troubleshoot power unit (see user's manual for your particular unit)
4	Poor hydraulic pressure at the tong despite adequate pressure at the power unit, or excessive back pressure in the return line.	Restrictions exist in line between power unit and tong. Inspect integrity of self-sealing couplings to ensure they are allowing full fluid flow. Check to ensure no other restrictions exist (contaminated catch screens or filters, for example)
5	Fluid viscosity is not appropriate (too high or too low)	Ensure hydraulic fluid being used is the viscosity recommended by McCoy Drilling & Completions. Power unit pump may not prime if fluid is too heavy, and the hydraulic system will overheat if fluid is too light. Replace with proper viscosity fluid Hydraulic fluid viscosity is affected by environmental conditions. Ensure the fluid being used is suitable for high or low temperatures. Replace with proper viscosity fluid for the operating conditions if necessary
6	Worn or damaged tong motor causing slippage	Replace or repair worn or damaged motor
7	Damaged bearings or gears causing excessive drag	Replace or repair worn or damaged gears or bearings
8	Jaws slipping on pipe	Ensure jaw dies are not worn to the point that they cannot grip. Ensure the correct sized jaws are in use
9	Torque gauge is indicating incorrectly	Incorrect gauge is being used. Ensure gauge is the proper range, and has been properly calibrated for the arm length of the equipment in use Gauge has been damaged. Check gauge operation and calibration on independent system Gauge has mistakenly been married to an incorrect load cell
10	Load cell is measuring incorrectly	Incorrect load cell is being used Air is trapped in torque measuring circuit (load cell, hydraulic line, or gauge. Refer to torque measurement troubleshooting in Section 6 of this manual Load cell has been damaged. Replace load cell, or return to McCoy for repair and re-calibration



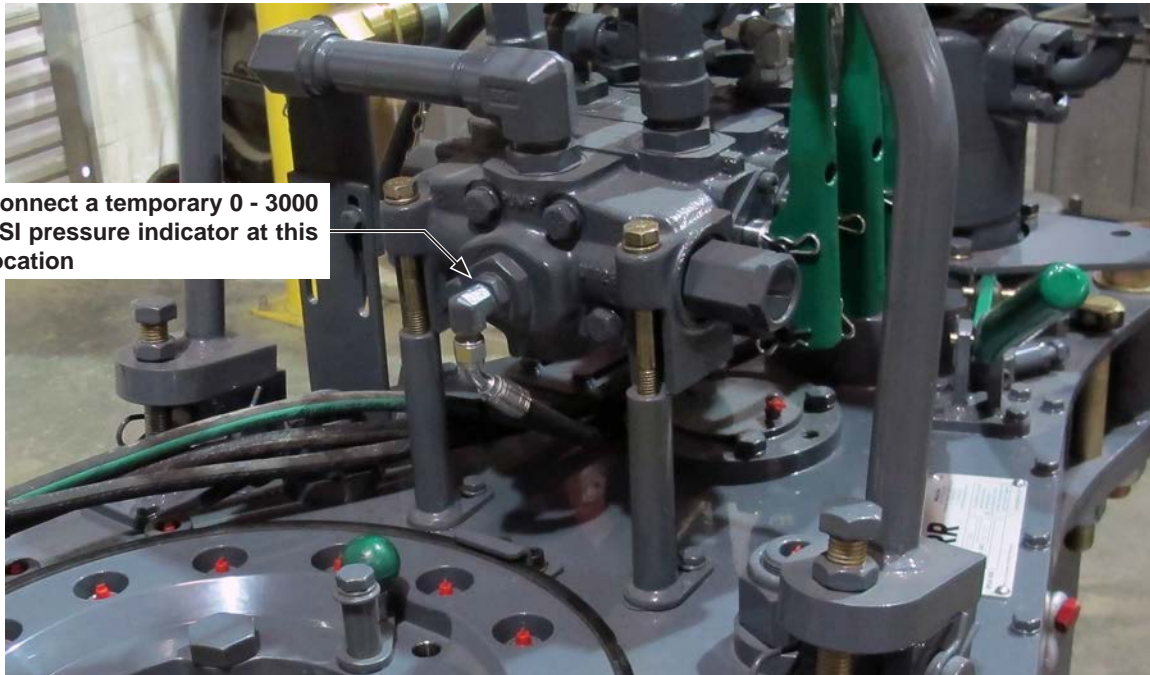
**MCCOY DRILLING & COMPLETIONS GUARANTEES CALIBRATION OF A LOAD CELL/TORQUE GAUGE ASSEMBLY FOR A PERIOD OF ONE YEAR. MCCOY SUGGESTS THAT THE LOAD CELL/TORQUE GAUGE ASSEMBLY BE RETURNED TO THE FACTORY FOR RE-CALIBRATION ON A YEARLY BASIS.**

	POSSIBLE PROBLEM	SOLUTION(S)
11	Incorrect motor speed selected (applies to 2-speed motors only)	Maximum torque can only be developed when LOW motor speed (maximum hydraulic displacement) is selected.
12	Incorrect tong gear selected	Maximum torque can only be developed when LOW motor gear is selected

4.B RELIEF VALVE IS INCORRECTLY SET OR NOT FUNCTIONING

	POSSIBLE PROBLEM	SOLUTION(S)
1	Relief pressure set too low, resulting in insufficient tong torque Relief pressure set too high, resulting in crushed pipe or gear train failure	Adjust setting (See following procedure):

- a. If your tong is equipped with a system pressure indicator proceed to step “f”. If your tong does not have a system pressure indicator, a temporary 0 - 3000 PSI indicator must be installed on the hydraulic inlet.
- b. Isolate your tong from hydraulic power, and depressurize following the procedure in section 3.D.
- c. Tee in a temporary indicator at the safety door supply pressure port. Ensure all hydraulic connections are performed by a qualified hydraulic technician.



**ILLUSTRATION 4.B.1: RELIEF VALVE TROUBLESHOOTING - TEMPORARY GAUGE INSTALLATION**

- d. Re-establish hydraulic power to your tong. Ensure that no equipment functions are active.
- e. Loosen the locking nut on the pressure relief valve.
- f. Open the tong door to activate the safety door system and inhibit tong rotation.
- g. Activate motor control valve. Observe the pressure displayed on the pressure indicator. Adjust the relief valve until the pressure indicated is at the maximum system pressure specified on the specifications page (maximum system pressure is the pressure at which your tong achieves its specified torque).



**DO NOT ADJUST PRESSURE RELIEF TO A SETTING THAT ALLOWS HIGHER THAN MAXIMUM SYSTEM PRESSURE. DOING SO CREATES A POTENTIAL FOR SERIOUS INJURY OR DEATH, AND MAY CAUSE CATASTROPHIC EQUIPMENT FAILURE.**

- h. Release the motor control valve and tighten the locking nut on the pressure relief valve.
- i. Isolate your tong from hydraulic power, and depressurize following the procedure in section 3.D.
- j. Close the tong door, and remove the temporary pressure indicator. Restore the safety door pressure supply line to factory specifications. Verify that safety door is operating correctly (see section 2.1.5.k).

*Continued on next page*



4.B RELIEF VALVE IS INCORRECTLY SET OR NOT FUNCTIONING (CONTINUED):

	POSSIBLE PROBLEM	SOLUTION(S)
2	Relief cannot be adjusted to maximum system pressure (high fluid bypass results in low system pressure)	Debris on valve seat
		Valve spring is broken
		Valve spring has lost spring force due to continuous tension

PROCEDURE:

- a. Isolate your tong from hydraulic power, and depressurize following the procedure in section 3.D
- b. Loosen the locking nut on the pressure relief valve.
- c. Use a large flat-head screwdriver to completely un-thread the poppet and spring from the relief assembly.
- d. Inspect the relief valve spring, poppet, and valve seat.
- e. If no debris is found in relief valve and if seat and poppet are undamaged, replace relief valve spring.
- f. Reassemble relief valve.
- g. Relief valve must be re-set to allow maximum system pressure. Follow the procedure in Step 1 of this section to properly adjust relief valve.
- h. If maximum system pressure still cannot be reached, replace the entire relief valve assembly.

**4.C SAFETY DOOR DOES NOT OPERATE OR IS MALFUNCTIONING**

	<b>POSSIBLE PROBLEM</b>	<b>SOLUTION(S)</b>
<b>1</b>	Safety door switch has failed	Test safety door switch for proper function and replace if necessary
<b>2</b>	Contamination in hydraulic lines	Ensure all three flexible hydraulic lines to safety door switch are free-flowing
<b>3</b>	Pilot-to-open valve in safety door valve block is malfunctioning.	Remove each valve. Inspect seats and springs. Replace valve(s) if damage is seen on valve seats, or if spring appears to be damaged or broken.

4.D TONG RUNNING TOO SLOWLY

	POSSIBLE PROBLEM	SOLUTION(S)
1	Obstruction in tong hydraulic circuit preventing adequate flow	Inspect self-sealing couplings to ensure they are properly engaged The main hydraulic lines (supply and discharge) to the tong are obstructed. Remove and clean if required
2	Power unit is not producing adequate flow or pressure	Troubleshoot power unit (see user's manual for your particular unit)
3	Tong motor is excessively worn and is leaking hydraulic fluid past the vanes	Replace motor, or rebuild as per Section 7 of this manual
4	Bearings in gear train and rotary section are excessively worn	Overhaul tong. See Section 3 of this manual for tong overhaul procedures
5	Shifter has malfunctioned and the tong is not shifting to high gear	Inspect and repair shift mechanism as necessary
6	Hydraulic fluid viscosity too high	Ensure hydraulic fluid meets McCoy Drilling & Completions specifications
		Ensure hydraulic fluid is appropriate for climatic conditions, especially during cold-weather operation
7	By-pass valve not functioning	Check and repair

**4.E FAILURE OF JAWS TO GRIP PIPE**

	<b>POSSIBLE PROBLEM</b>	<b>SOLUTION(S)</b>
1	Dies have become too dull to provide adequate grip	Replace dies
2	Incorrect jaws are being used	Double-check jaw size to ensure they are rated for the diameter of pipe or casing being run
3	Incorrect dies are being used	Ensure dies loaded in the jaws are appropriate for the type of pipe or casing being run
4	Brake band(s) is (are) insufficiently adjusted, not allowing jaws to cam properly	Adjust brake bands to give proper resistance to cage plates
5	Jaw roller broken or worn	Remove jaw assembly and inspect. Replace rollers that are visibly "flat-spotted" or otherwise damaged

4.F FAILURE OR DIFFICULTY OF TONG TO SHIFT

	POSSIBLE PROBLEM	SOLUTION(S)
1	Bent or broken shifter handle	Replace shifter handle
2	Bent or broken shifter yoke	Inspect components through inspection door. Replace shifter yoke if necessary.
3	“Frozen” or hard-to-move shifter handle	Grease shifter shaft
4	Bent or broken shifter shaft	Replace
5	Locking nuts on shifting shaft have loosened and position of yoke has changed	Reposition yoke and re-tighten locking nuts
6	Shifting yoke has come loose from shifting shaft	Inspect yoke and inspect for damage. If free of damage, replace on shaft and tighten locking nuts
7	Tong pops out of gear	Ensure that detent ball & spring assembly has been correctly set

**4.G GENERAL COMMENTS**

The following factors generally contribute to poor hydraulic operation and premature wear of equipment:

1. Contaminated hydraulic fluid due to overuse, overheating, or inadequate fluid filtration.
2. Unsuitable hydraulic fluid, especially in extreme climatic conditions.
3. Defective packing or seals in components of the hydraulic system.
4. Poor or incomplete hydraulic system training. Users must be fully qualified to operate the equipment, and have complete understanding of the hydraulic system.

If your hydraulic troubleshooting procedures involve flow and pressure tests at the power unit, McCoy Global recommends construction of a test rig that can easily be connected to the main suction and discharge ports of the power unit.





SECTION 5: PARTS & ASSEMBLIES

The following table lists parts that McCoy Global has identified as critical spare parts for this model of tong. McCoy recommends that the specified quantity of each part be on hand at all times.

<b>CRITICAL SPARE PARTS LIST</b>		
<b>MISC TONG PARTS</b>		
<b>Description</b>	<b>Part Number</b>	<b>Qty. Required</b>
Jaw pivot bolt	1050-C5-28	1
Lined brake band weldment	1037-D-63	2
Door spring stop cylinder	1037-A4-144	1
Door latch adjustment cam	1037-C-151	1
Door latch shaft	1037-C-200	1
Door latch spring	997-16	2
Backing pin	1037-C-39A	1
Shifting shaft	1037-C-20A	1
Shifting fork	1037-D-27	1
Safety door latch claw (RH)	AE13-302M	1
Safety door latch claw (LH)	AE13-301S	1
Safety door load plunger	AE12-306	1
Chain sling shackle assembly	02-9063	2
Chain sling turnbuckle assembly	101-5776	2
Tong body handle	101-5782	1
<b>BEARINGS &amp; BUSHINGS</b>		
<b>Description</b>	<b>Part Number</b>	<b>Qty. Required</b>
Bottom clutch bearing	02-0105	1
Pinion bearing	02-0106	2
<b>FASTENERS &amp; FITTINGS</b>		
<b>Description</b>	<b>Part Number</b>	<b>Qty. Required</b>
½" UNC x 8" hex bolt, cage plate	09-1198	2
⅝" x ¾" UNC shoulder bolt (door cylinder mount)	09-0049	2
<b>HYDRAULIC COMPONENTS</b>		
<b>Description</b>	<b>Part Number</b>	<b>Qty. Required</b>
Relief cartridge (DVA35)	10-0062	1
Relief cartridge (safety door)	08-1625	1
Safety door switch	08-0337M	1
Hydraulic hose - lift cylinder supply (If lift cylinder is installed)	02-0934H	1
High-visibility protective wrap, lift cylinder hose (If lift cylinder is installed)	02-E0203	1
<b>JAW COMPONENTS</b>		
<b>Description</b>	<b>Part Number</b>	<b>Qty. Required</b>
Jaw roller	1037-JRS-275S	2
Jaw pin	1037-JPSG-375	2
3.875" flat die insert	13-0008-314-0	12
5" Jaw die, flat	13-0008-500-0	48

ITEMS ON THE CRITICAL SPARE PARTS LIST MARKED IN RED INDICATE ESSENTIAL HEALTH & SAFETY ITEMS. FAILURE TO REPLACE DAMAGED ESSENTIAL HEALTH & SAFETY ITEMS WILL PRESENT IMMEDIATE DANGER TO PERSONNEL OR EQUIPMENT. HAVE THESE ITEMS ON HAND AT ALL TIMES. STOP WORK AND QUARANTINE TONG UPON DISCOVERY OF DAMAGED OR DEFECTIVE HEALTH AND SAFETY COMPONENTS UNTIL PARTS CAN BE REPLACED.

In addition to the critical spare parts identified on the previous page, McCoy suggests stocking the following spare parts. Even though these are not critical spares, stocking these components may significantly decrease repair time in the event of long lead times from the factory.

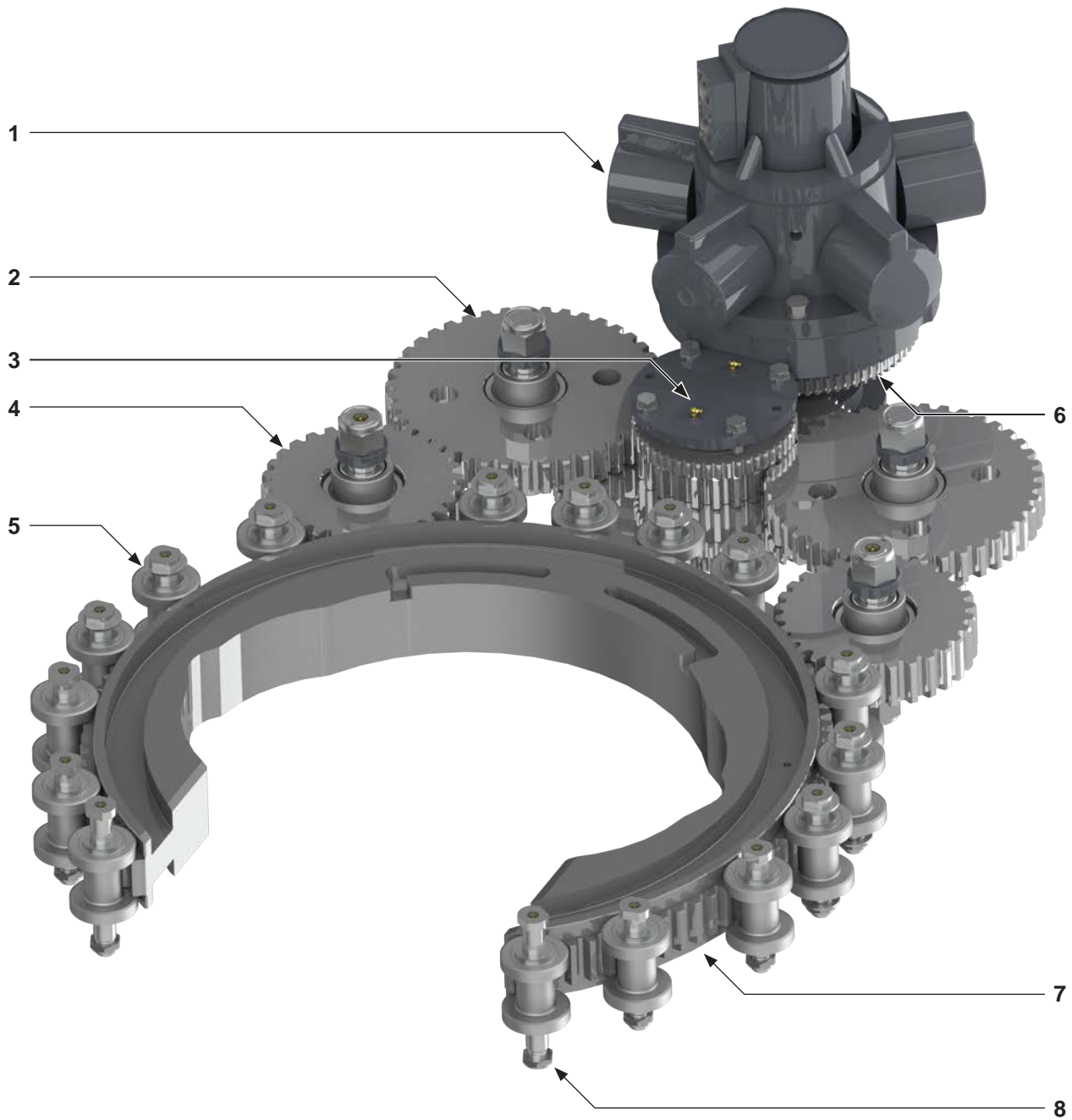
<b>RECOMMENDED SPARE PARTS LIST</b>		
<b>MISC TONG PARTS</b>		
<b>Description</b>	<b>Part Number</b>	<b>Qty. Required</b>
Small cam follower mounting bracket	1037-A-49	2
Door cylinder mounting post	101-0446	1
Support dumbbell roller	1037-135	2
Support roller spacer	101-3871	4
Support roller Inner spacer	1037-C-134	2
Support roller shaft	101-3939	2
Support roller shaft, door pivot	101-3940	1
Brake band retainer	101-1631	1
Brake band adjustment spring	08-9264	2
Cage plate spacer	1037-C-38	1
Motor thrust washer (Staffa motor only)	101-3289	1
Motor manifold block (Staffa motor only)	87-0209	1
Rear cage plate bolt	1037-36	1
Backing pin retainer	1037-B-54	1
Shifter detent force spring	997-0-64	1
Shifter detent force ball	02-0018	1
Shifting link	02-0120	2
<b>BEARINGS &amp; BUSHINGS</b>		
<b>Description</b>	<b>Part Number</b>	<b>Qty. Required</b>
Cam followers (body plate)	1037-0-58	10
Cam followers (small)	02-0108	2
Support roller bearings	02-0094	4
Shoulder bushing, door pivot	101-0110	2
<b>FASTENERS &amp; FITTINGS</b>		
<b>Description</b>	<b>Part Number</b>	<b>Qty. Required</b>
$\frac{7}{8}$ " UNF jam nut (cam follower)	09-1489	10
$\frac{7}{8}$ " lock washer (cam follower)	09-5122	10
$\frac{7}{16}$ " UNF thin nylock nut (small cam followers)	09-5708	2
10-24 x 1" hex socket head cap screws (cam follower mounting bracket)	09-9137	4
$\frac{3}{8}$ " UNC x 4- $\frac{1}{2}$ " brake band adjustment bolt	09-1064	2
$\frac{3}{8}$ " UNC nylock nut, brake band adjustment	09-5607	2
$\frac{5}{8}$ " x $\frac{3}{4}$ " UNC shoulder bolt (door cylinder mount)	09-0049	2
$\frac{7}{16}$ " UNF x 1- $\frac{1}{2}$ " hex bolt (shifter detent force adjustment bolt)	09-1110	1
$\frac{7}{16}$ " UNF hex jam nut (shifter detent force lock nut)	09-5508	1
$\frac{5}{16}$ " x 1- $\frac{1}{2}$ " clevis pin	09-0256	3
Grease fitting, $\frac{1}{8}$ " NPT, 90 degree	02-0093	4
Grease fitting, $\frac{1}{8}$ " NPT	02-0005	4
Grease fitting, $\frac{1}{4}$ " straight thread	02-0097	4
<b>HYDRAULIC COMPONENTS</b>		
<b>Description</b>	<b>Part Number</b>	<b>Qty. Required</b>
Seal kit - DVA35	07-0004	2

The following tables list parts McCoy Drilling & Completions recommends replacing when performing a complete overhaul of your tong assembly.

<b>MISC TONG PARTS REQUIRED FOR OVERHAUL</b>		
<b>Description</b>	<b>Part Number</b>	<b>Qty. Required</b>
Support dumbbell roller	1037-135	16
Support roller spacer	101-3871	32
Support roller inner spacer	1037-C-134	16
Support roller shaft	101-3939	14
Support roller shaft, door pivot	101-3940	2
Small cam follower mounting bracket	1037-A-49	10
Jaw pivot bolt	1050-C5-28	2
Pinion gear keys (if required)	1037-D-15A	4
Idler gear retaining ring	02-0009	8
Idler bearing seal	02-0010	8
Shifting collar	1037-D-34	1
Cage plate spacer	1037-C-38	3
Rear cage plate bolt	1037-36	1
Backing pin retainer	1037-B-54	1
Backing pin	1037-C-39A	1
Lined brake band weldment	1037-D-63	2
Brake band retainer	101-1631	4
Brake band adjustment spring	08-9264	4
Shifting shaft	1037-C-20A	1
Shifting fork	1037-D-27	1
Shifter detent force spring	997-0-64	1
Shifter detent force ball	02-0018	1
Shifting link	02-0120	2
Motor thrust washer (Staffa motor only)	101-3289	1
Door spring stop cylinder	1037-A4-144	2
Door latch adjustment cam	1037-C-151	2
Door latch shaft	1037-C-200	1
Door latch spring	997-16	2
Door cylinder mounting post	101-0446	2
Safety door latch claw (RH)	AE13-302M	1
Safety door latch claw (LH)	AE13-301S	1
Safety door load plunger	AE12-306	1
Chain sling shackle assembly	02-9063	2
Chain sling turnbuckle assembly	101-5776	2
Tong body handle	101-5782	1

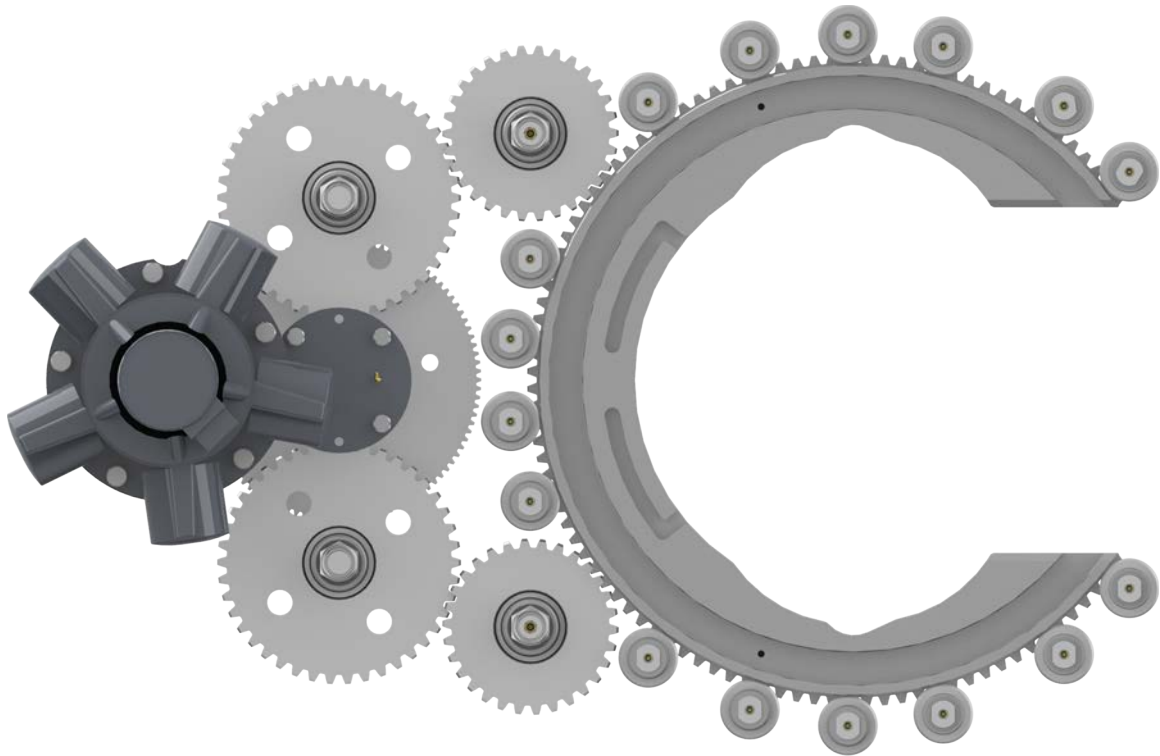
BEARINGS & BUSHINGS REQUIRED FOR OVERHAUL		
Description	Part Number	Qty. Required
Cam followers (body plate)	1037-0-58	50
Cam followers (small)	02-0108	10
Support roller bearings	02-0094	32
Pinion bearing	02-0106	2
Idler bearing	02-0106	8
Upper clutch bearing	02-0103	2
Lower clutch bearing	02-0104	1
Bottom clutch bearing	02-0105	1
Shoulder bushing, door pivot	101-0110	4
FASTENERS & FITTINGS REQUIRED FOR OVERHAUL		
Description	Part Number	Qty. Required
$\frac{7}{8}$ " UNF jam nut (cam follower)	09-1489	50
$\frac{7}{8}$ " lock washer (cam follower)	09-5122	50
$\frac{7}{16}$ " UNF thin nylock nut (small cam followers)	09-5628	10
10-24 x 1" hex socket head cap screws (cam follower mounting bracket)	09-9137	20
$\frac{1}{2}$ " UNC x 8" hex bolt, cage plate	09-1198	2
$\frac{3}{8}$ " UNC x 4- $\frac{1}{2}$ " brake band adjustment bolt	09-1064	4
$\frac{3}{8}$ " UNC nylock nut, brake band adjustment	09-5607	4
$\frac{7}{16}$ " UNF x 1- $\frac{1}{2}$ " hex bolt (shifter detent force adjustment bolt)	09-1110	1
$\frac{7}{16}$ " UNF hex jam nut (shifter detent force lock nut)	09-5508	1
$\frac{5}{16}$ " x 1- $\frac{1}{2}$ " clevis pin	09-0256	3
$\frac{5}{8}$ " x $\frac{3}{4}$ " UNC shoulder bolt (door cylinder mount)	09-0049	2
Grease fitting, $\frac{1}{8}$ " NPT, 90 degree	02-0093	6
Grease fitting, $\frac{1}{8}$ " NPT	02-0005	5
Grease fitting, $\frac{1}{4}$ " straight thread	02-0097	16
HYDRAULIC COMPONENTS REQUIRED FOR OVERHAUL		
Description	Part Number	Qty. Required
Motor manifold block (Staffa motor only)	87-0209	1
Seal Kit, Staffa hydraulic motor only	87-7210	1
Seal Kit, Rineer hydraulic motor only	87-7150	1
Relief cartridge (safety door)	08-1625	2
Safety door switch	08-0337M	1
Seal kit - DVA35	07-0004	2
System relief valve	10-0062	1
Hydraulic hose - lift cylinder supply (If lift cylinder is installed)	02-0934H	1
High-visibility protective wrap, lift cylinder hose (If lift cylinder is installed)	02-E0203	1

ITEMS ON THE CRITICAL SPARE PARTS LIST MARKED IN **RED** INDICATE ESSENTIAL HEALTH & SAFETY ITEMS. FAILURE TO REPLACE DAMAGED ESSENTIAL HEALTH & SAFETY ITEMS WILL PRESENT IMMEDIATE DANGER TO PERSONNEL OR EQUIPMENT. HAVE THESE ITEMS ON HAND AT ALL TIMES. STOP WORK AND QUARANTINE TONG UPON DISCOVERY OF DAMAGED OR DEFECTIVE HEALTH AND SAFETY COMPONENTS UNTIL PARTS CAN BE REPLACED.

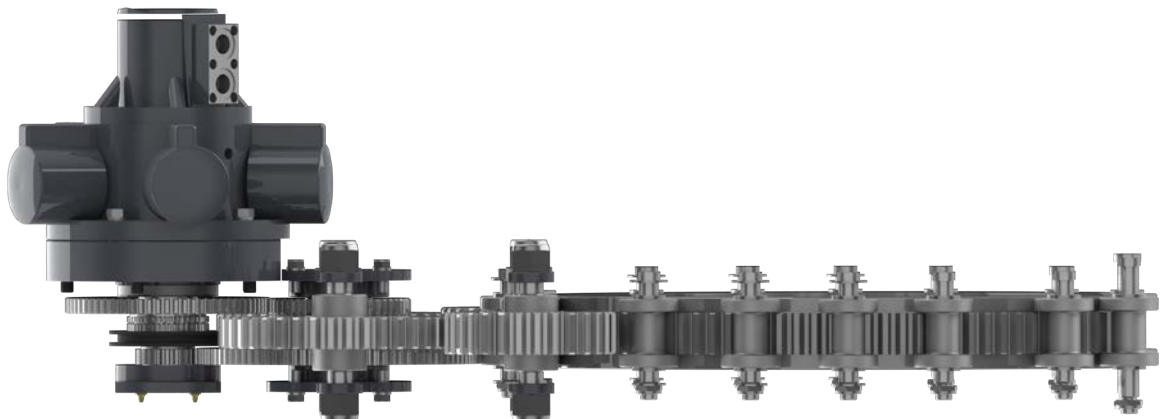


**ILLUSTRATION 5.1: KT20-50K GEAR TRAIN ISO VIEW**



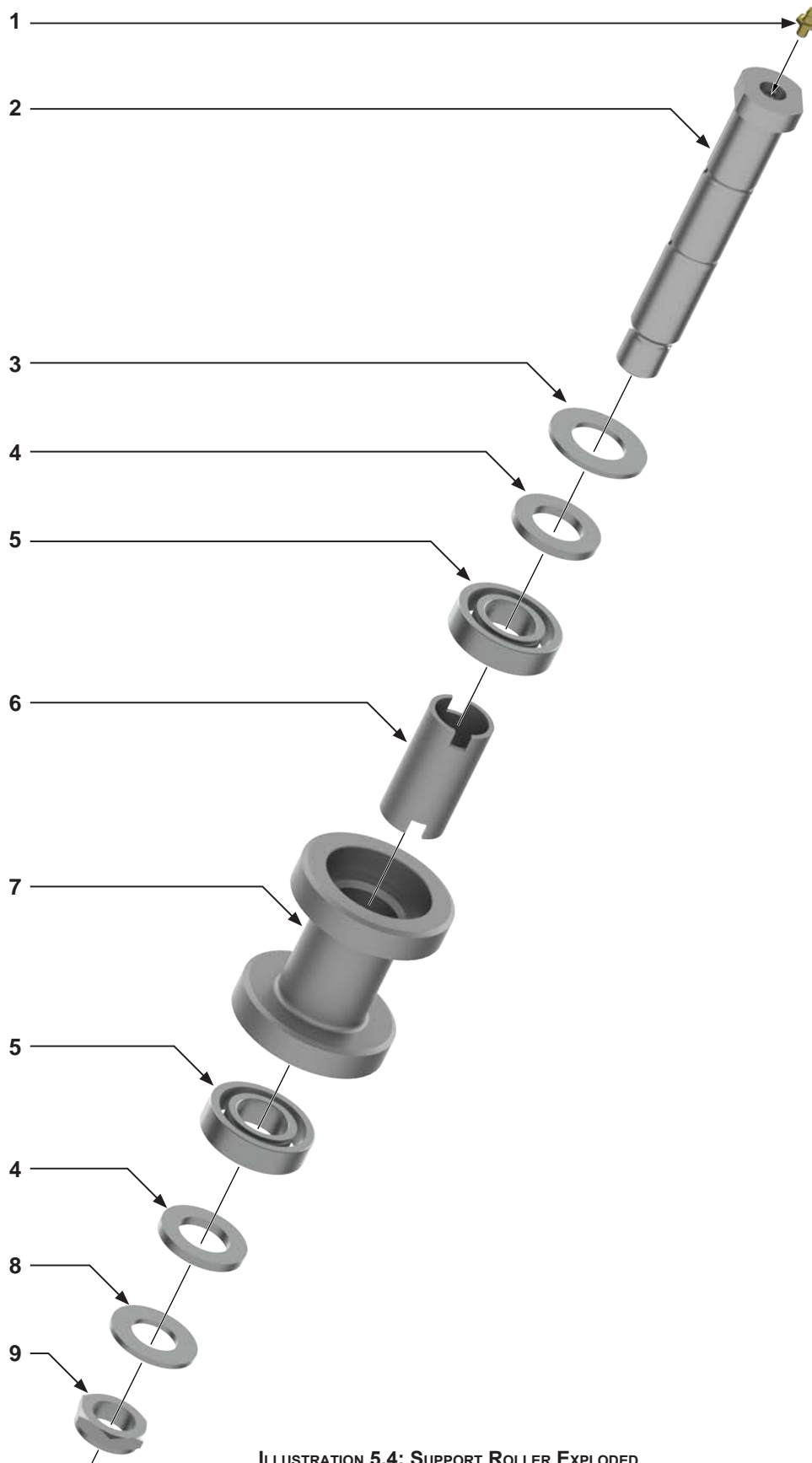


**ILLUSTRATION 5.2: KT20-50K GEAR TRAIN TOP VIEW**



**ILLUSTRATION 5.3: KT20-50K GEAR TRAIN SIDE VIEW**

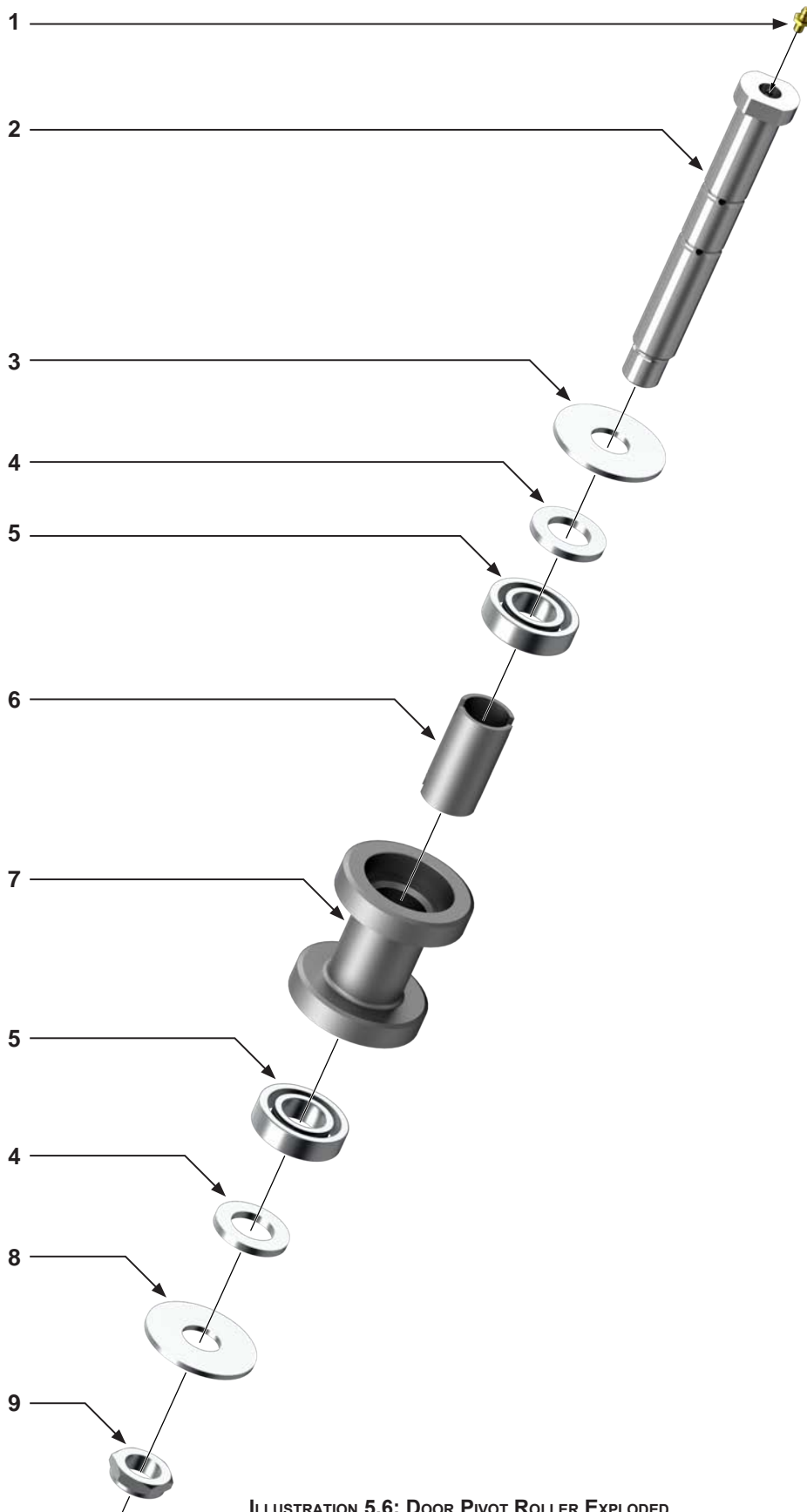
Item	Type	Description	Qty	Part Number
1	Part	Staffa hydraulic motor	1	87-0210B
	Part	Rineer hydraulic motor (optional)	1	87-0150
2	Assembly	Pinion idler assembly (Pp. 5.14 - 5.15)	2	
3	Assembly	Pinion gear assembly (Pp. 5.16 - 5.17)	1	
4	Assembly	Rotary idler assembly (Pp. 5.12 - 5.13)	2	
5	Assembly	Support roller assembly (Pp. 5.8 - 5.9)	14	
6	Assembly	Clutch assembly (Pp. 5.18 - 5.19)	1	
7	Part	Rotary gear	1	1037-D-46
8	Assembly	Door pivot roller assembly (Pp. 5.10 - 5.11)	2	



**ILLUSTRATION 5.4: SUPPORT ROLLER EXPLODED**

**ILLUSTRATION 5.5: SUPPORT ROLLER**

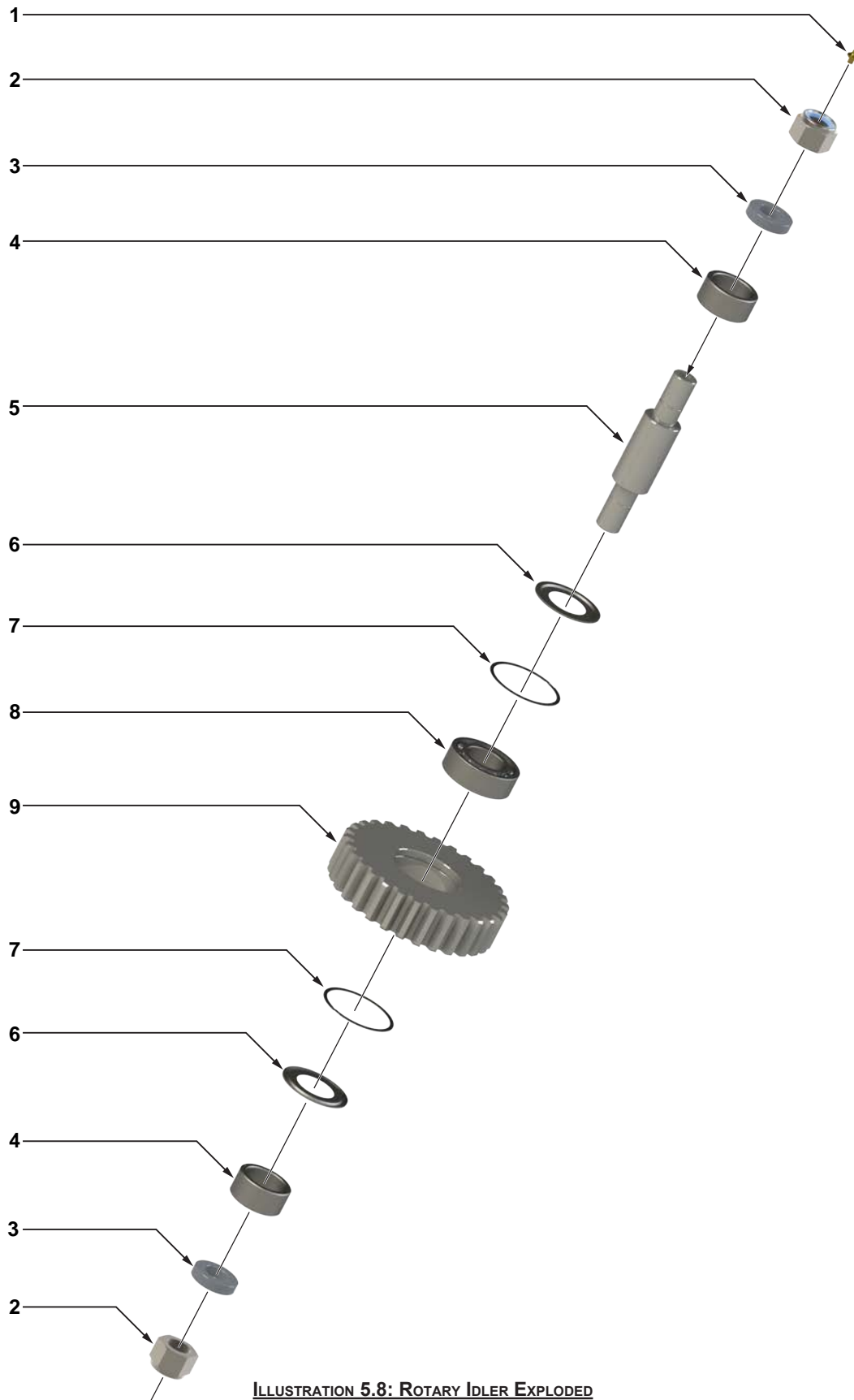
Item	Type	Description	Qty	Part Number
1	Part	¼" UNF straight grease fitting	1	02-0097
2	Part	Support roller shaft	1	101-3939
3	Part	1-½" plain flat washer	1	09-5041
4	Part	Bearing spacer	2	101-3871
5	Part	Support roller bearing	2	02-0094
6	Part	Support roller spacer	1	1037-C-134
7	Part	Support roller	1	1037-135
8	Part	1" Narrow flat washer	1	09-5026
9	Part	1" UNS thin nylock nut	1	09-5627



**ILLUSTRATION 5.6: DOOR PIVOT ROLLER EXPLODED**

**ILLUSTRATION 5.7: DOOR PIVOT ROLLER**

Item	Type	Description	Qty	Part Number
1	Part	¼" UNF straight grease fitting	1	02-0097
2	Part	Support roller shaft	1	101-3940
3	Part	1-½" flat washer	1	09-5041
4	Part	Bearing spacer	2	101-3871
5	Part	Support roller bearing	2	02-0094
6	Part	Support roller spacer	1	1037-C-134
7	Part	Support roller	1	1037-135
8	Part	1" regular flat washer	1	09-5026
9	Part	1" UNS thin nylock nut	1	09-5627



**ILLUSTRATION 5.8: ROTARY IDLER EXPLODED**



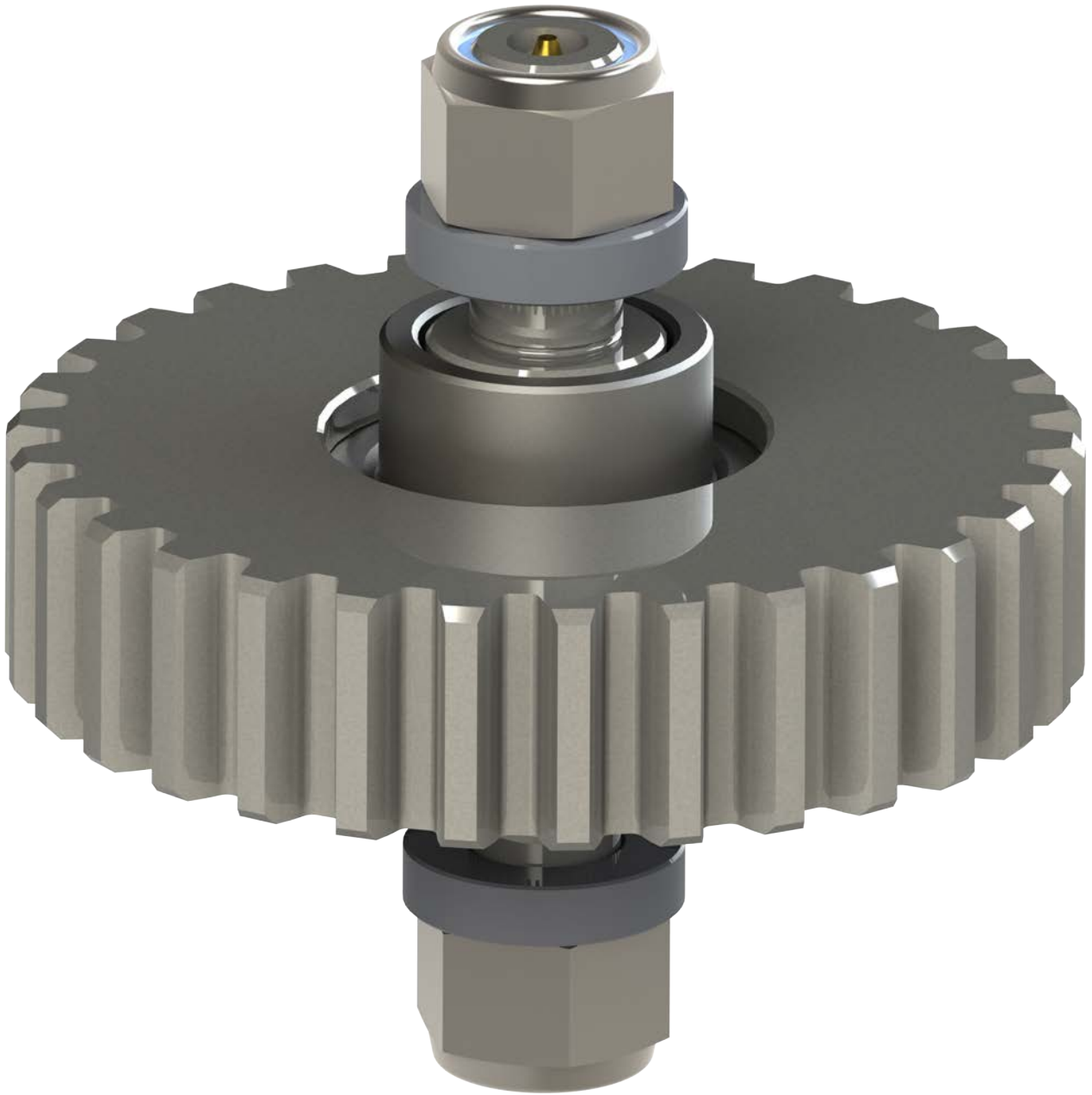
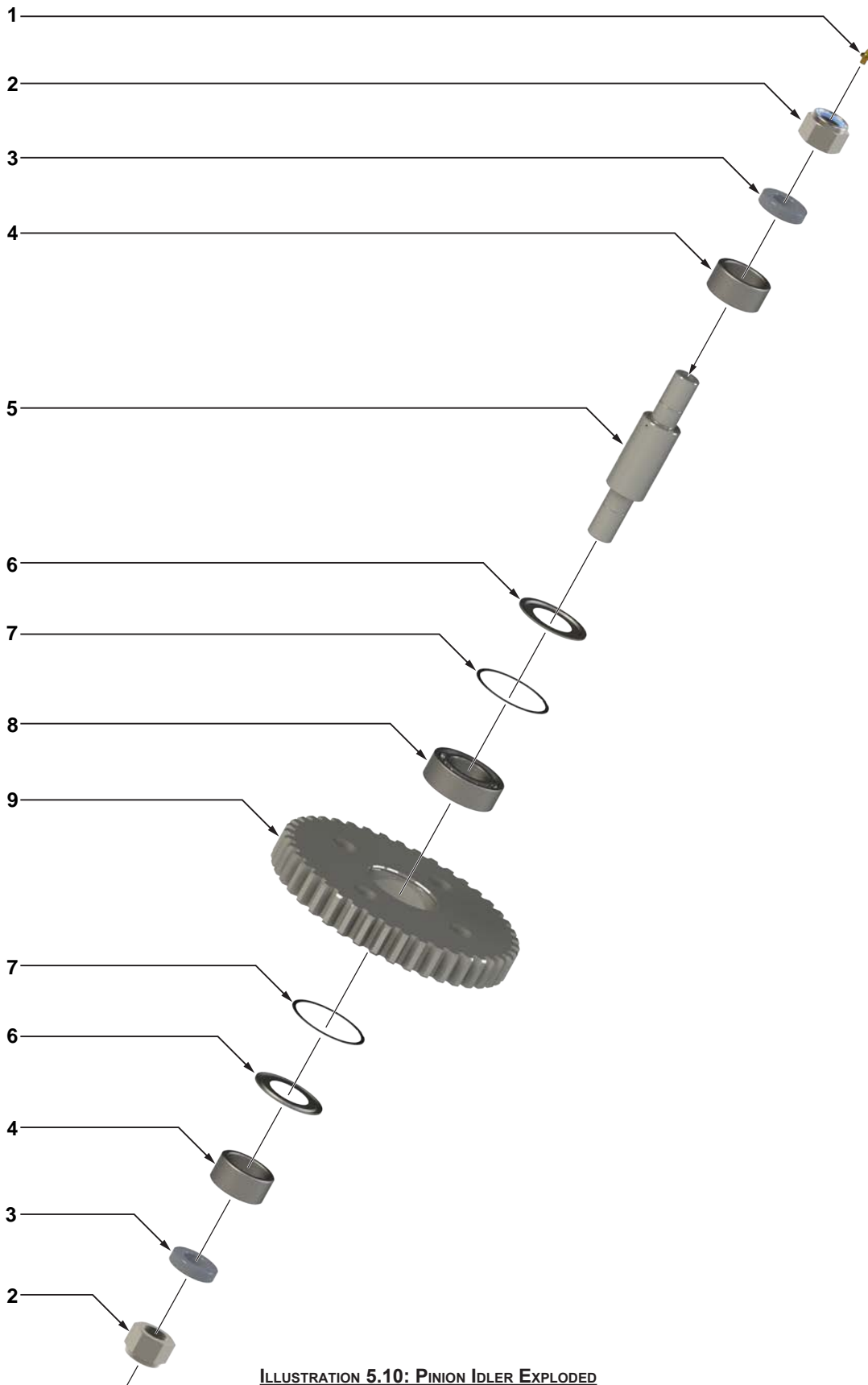
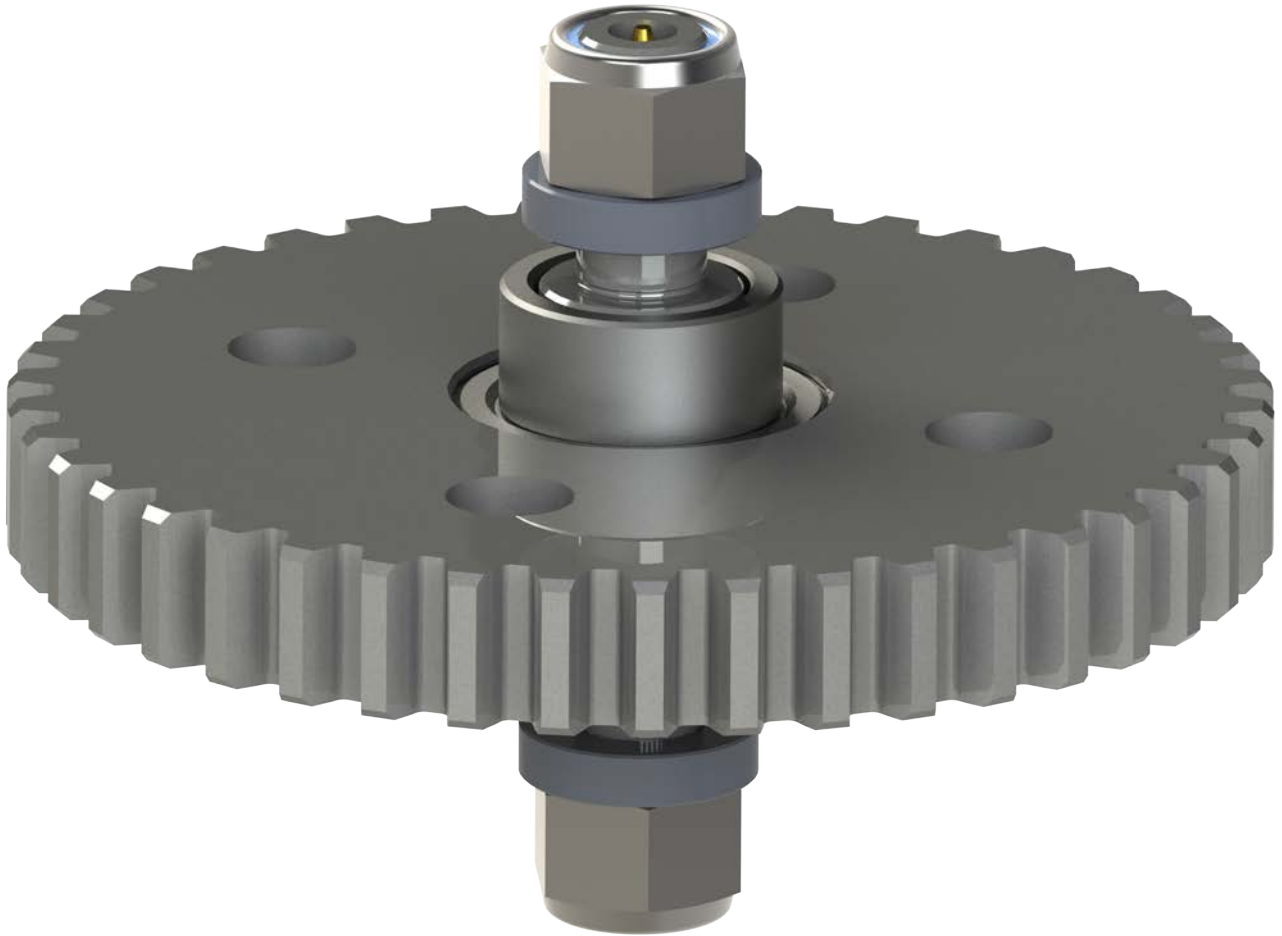


ILLUSTRATION 5.9: ROTARY IDLER

Item	Type	Description	Qty	Part Number
1	Part	1/8" NPT Grease Fitting	1	02-0005
2	Part	1-1/2" UNF Nylock Nut	2	09-5740
3	Part	Idler Pad	2	997-D20-125
4	Part	Idler Spacer	2	1050-D5-121
5	Part	Rotary Idler Shaft	1	1050-D5-117
6	Part	Bearing Seal	2	02-0010
7	Part	Retainer Clip	2	02-0009
8	Part	Cylindrical Roller Bearing	1	02-0011
9	Part	Rotary Idler Gear	1	1037-D59



**ILLUSTRATION 5.10: PINION IDLER EXPLODED**



**ILLUSTRATION 5.11: PINION IDLER**

Item	Type	Description	Qty	Part Number
1	Part	1/8" NPT grease fitting	1	02-0005
2	Part	1-1/2" UNF nylock nut	2	09-5740
3	Part	Idler pad	2	997-D20-125
4	Part	Idler spacer	2	1050-D5-121
5	Part	Pinion idler shaft	1	1050-D5-117
6	Part	Bearing seal	2	02-0010
7	Part	Retainer clip	2	02-0009
8	Part	Cylindrical roller bearing	1	02-0011
9	Part	Pinion Idler gear	1	1037-D-1

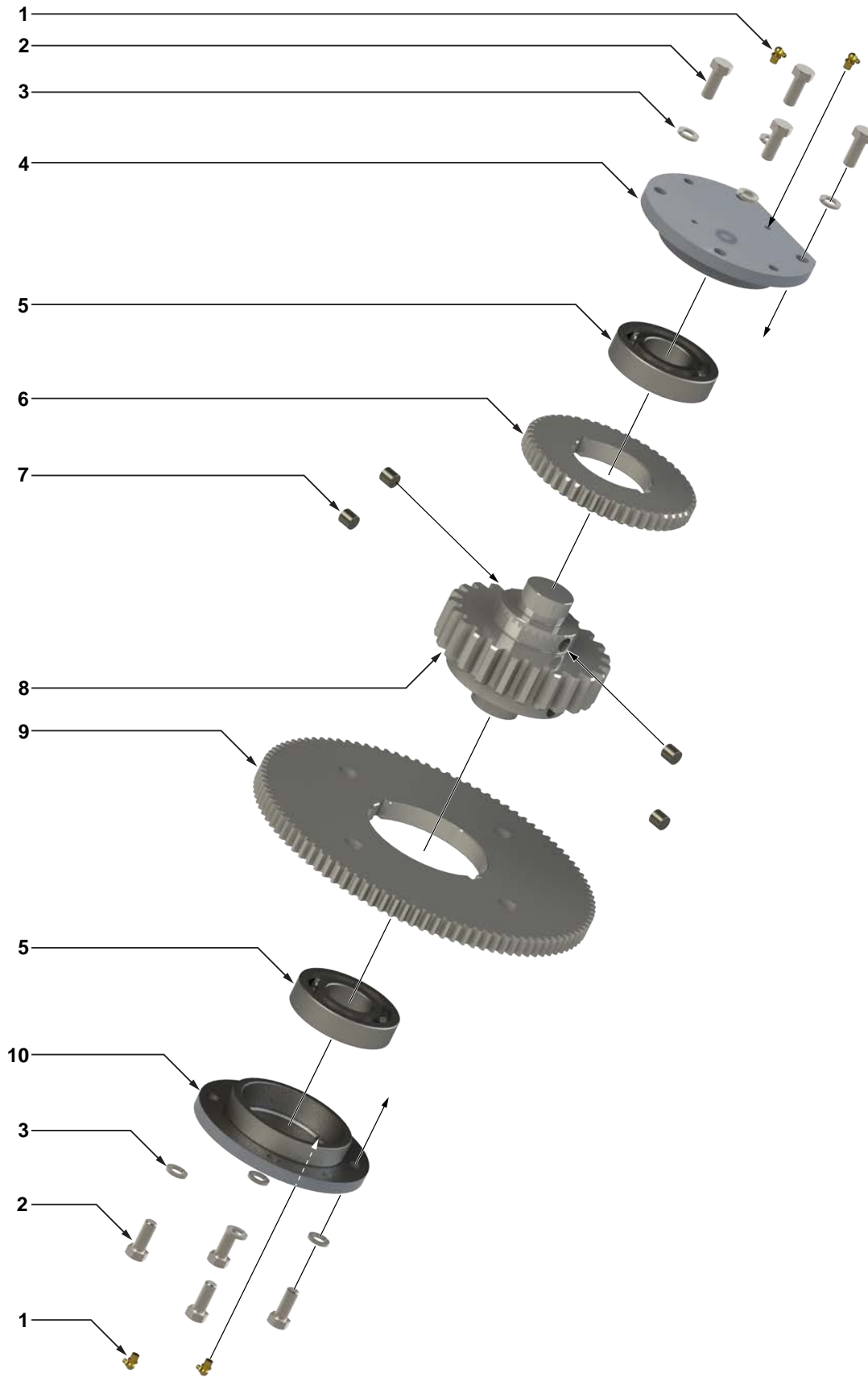
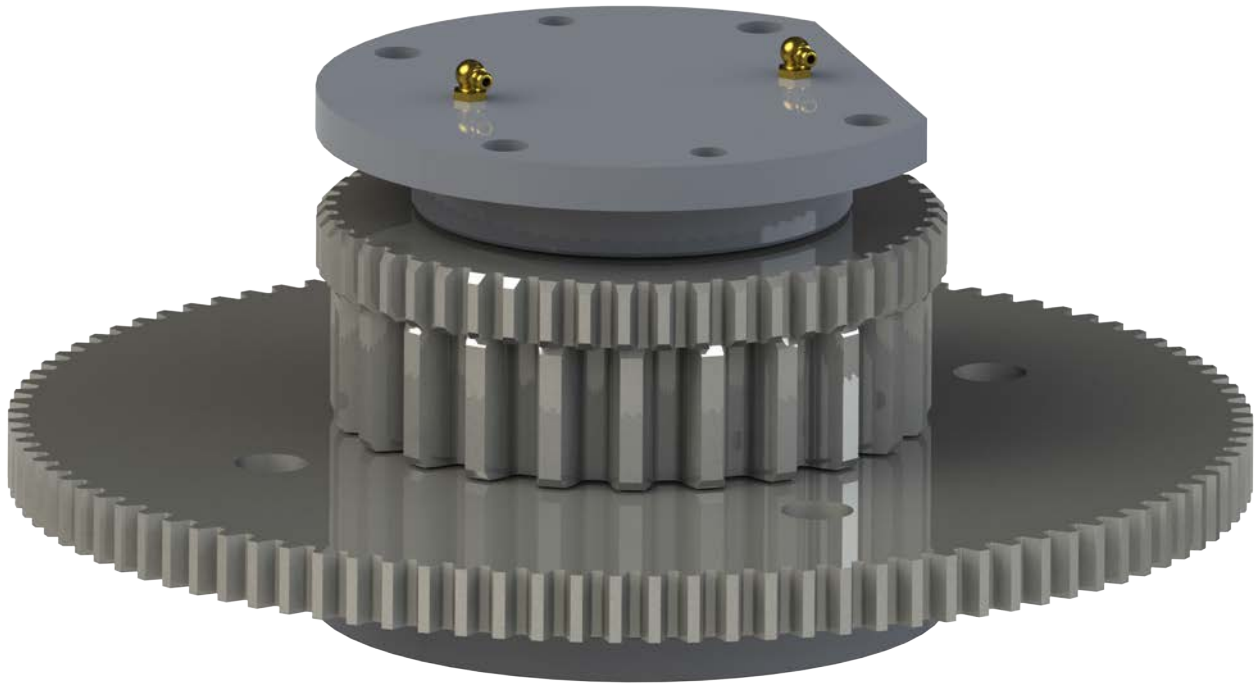


ILLUSTRATION 5.12: PINION GEAR ASSEMBLY EXPLODED



**ILLUSTRATION 5.13: PINION GEAR ASSEMBLY**

Item	Type	Description	Qty	Part Number
1	Part	1/8" NPT x 90° grease fitting	4	02-0093
2	Part	5/8" UNC x 1-1/4" hex bolt	8	09-1228
3	Part	5/8" lock washers	8	09-5114
4	Part	Top pinion bearing cap	1	1037-C-10
5	Part	Pinion bearing	2	02-0106
6	Part	High pinion gear	1	1037-D-12
7	Part	Gear key	4	1037-D-15A
8	Part	Pinion gear	1	1037-D-15
9	Part	Low pinion gear	1	1037-D-32
10	Part	Bottom pinion bearing cap	1	1037-C-33

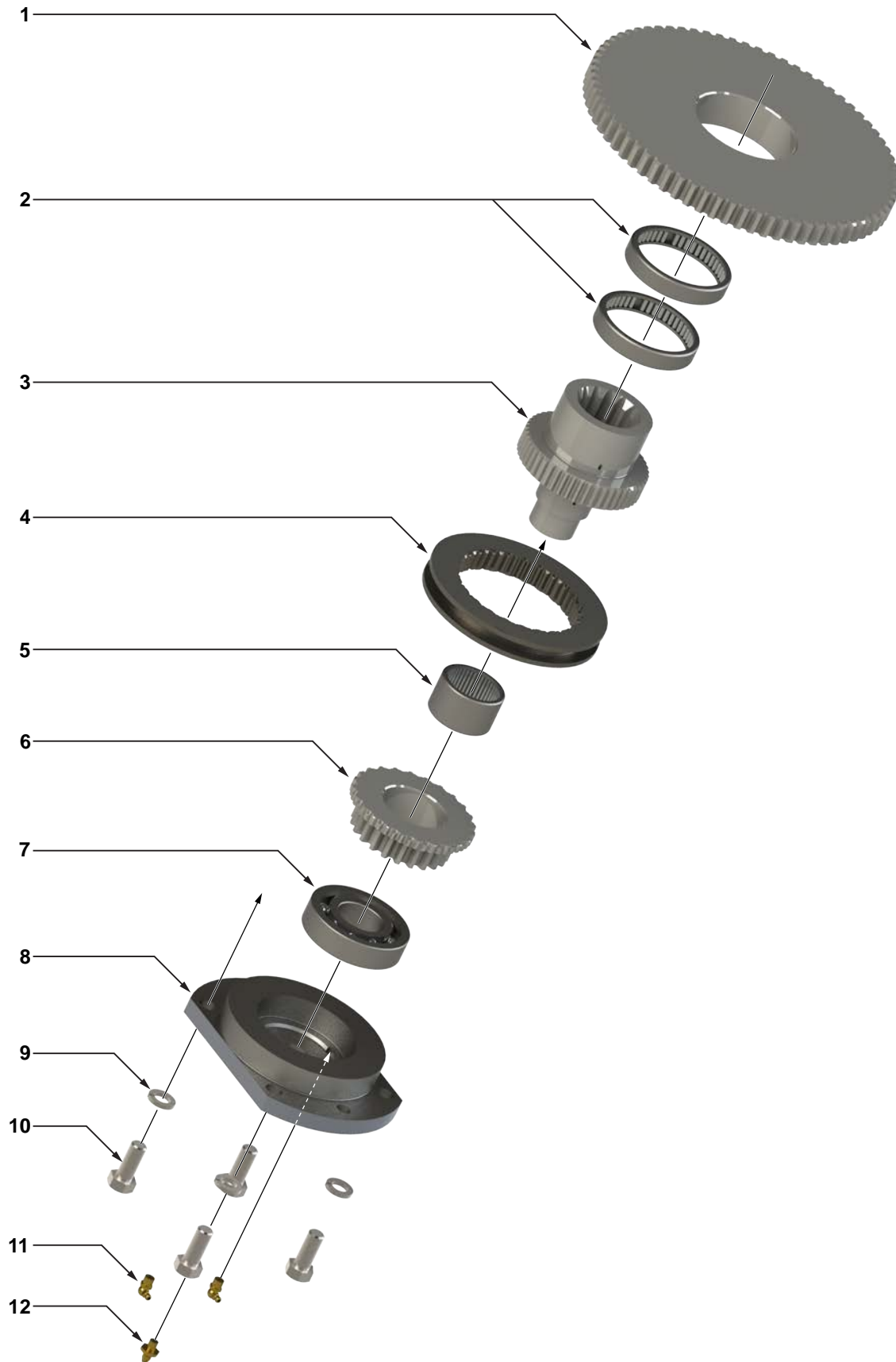


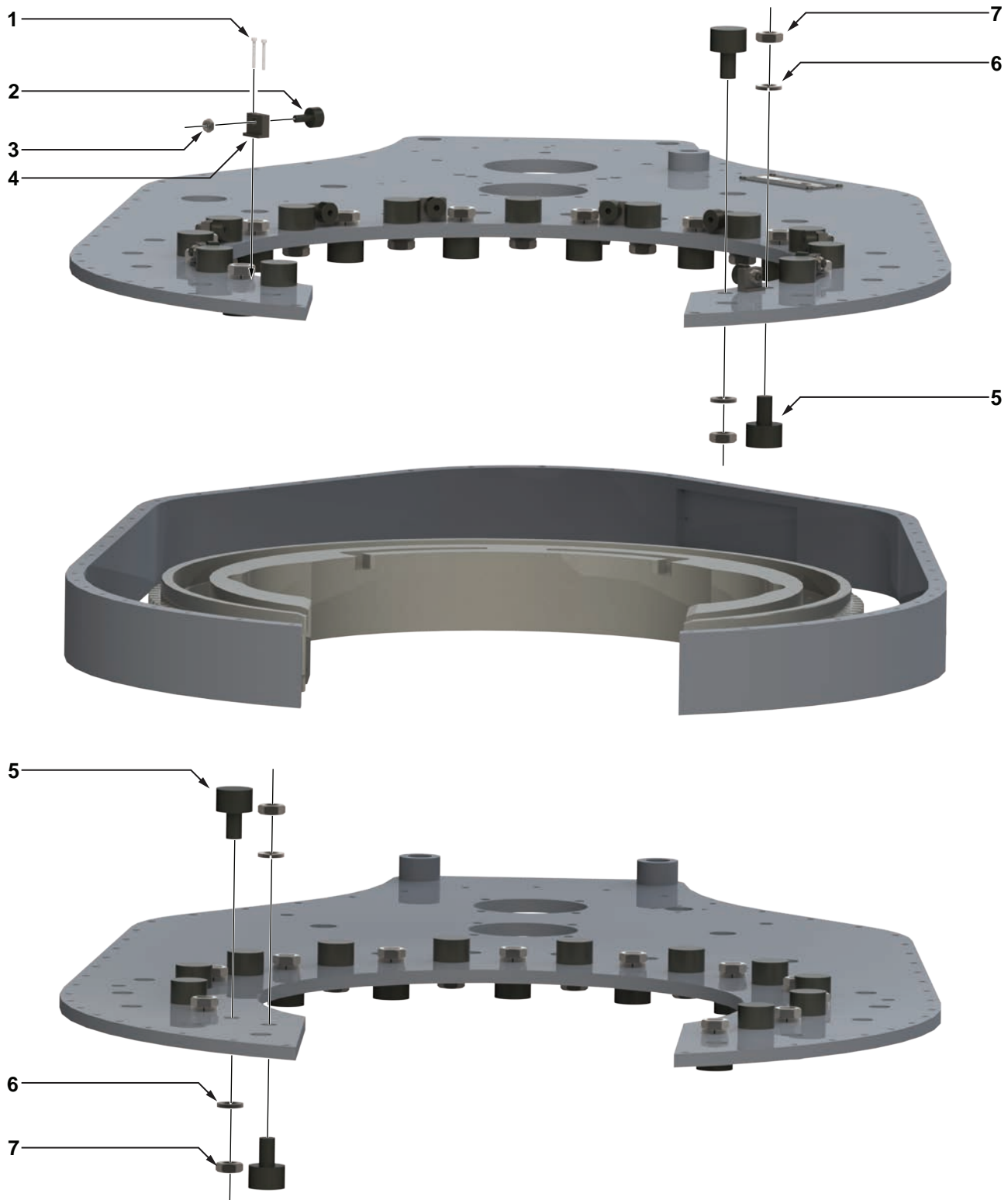
ILLUSTRATION 5.14: CLUTCH GEAR ASSEMBLY EXPLODED



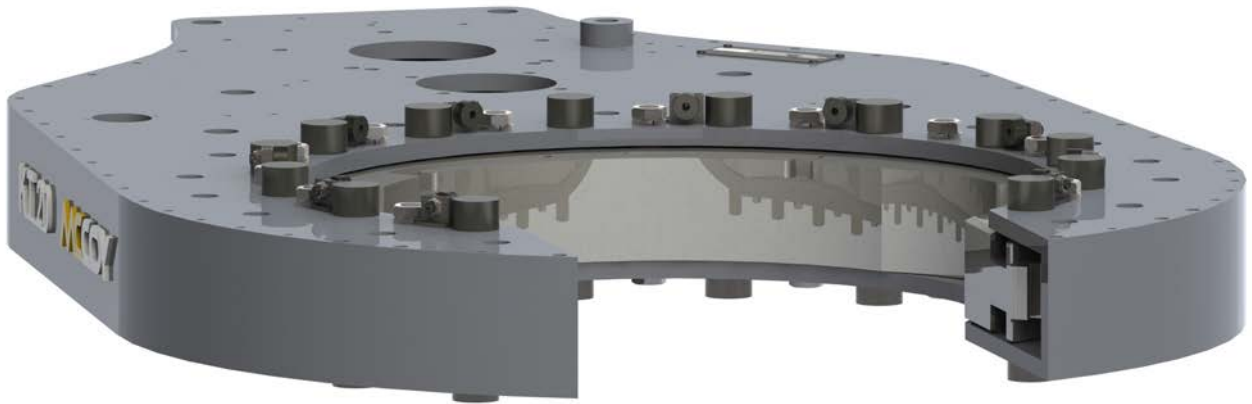
**ILLUSTRATION 5.15: CLUTCH GEAR ASSEMBLY**

Item	Type	Description	Qty	Part Number
1	Part	High clutch gear	1	1037-D-41
2	Part	Top clutch bearing	2	02-0103
3	Part	Splined clutch shaft	1	1037-D-38
4	Part	Shifting collar	1	1037-D-34
5	Part	Clutch bearing	1	02-0104
6	Part	Low clutch gear	1	1037-D-40
7	Part	Bottom clutch bearing	1	02-0105
8	Part	Clutch bearing cap	1	1037-C-17
9	Part	5/8" lock washer	4	09-5114
10	Part	5/8" UNC x 1-1/2" hex bolt	4	09-1230
11	Part	1/8" NPT x 90° grease fitting	2	02-0093
12	Part	1/8" NPT grease fitting	1	02-0005



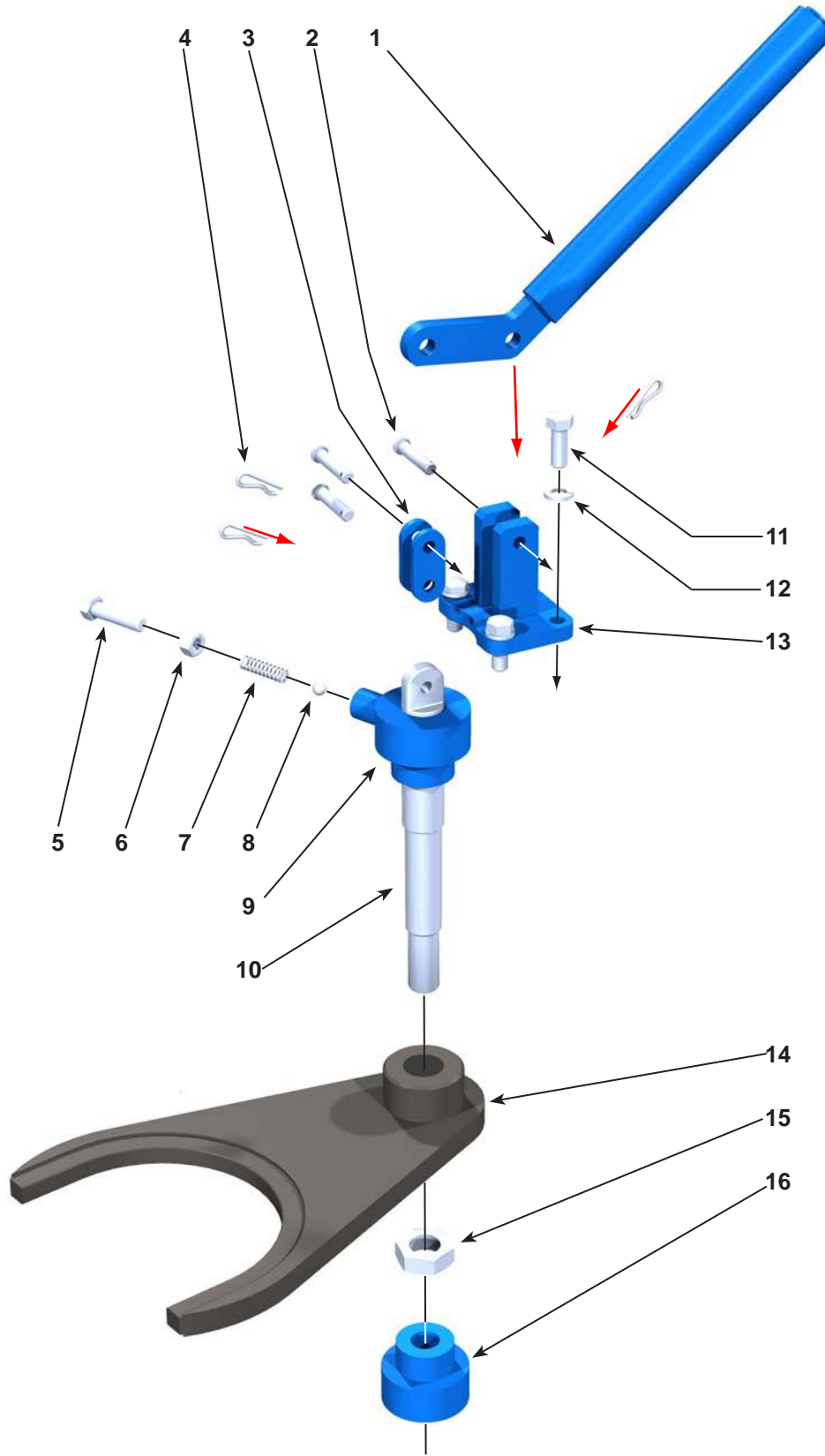


**ILLUSTRATION 5.16: CAM FOLLOWER ARRAY EXPLODED**



**ILLUSTRATION 5.17: CAM FOLLOWER ARRAY**

Item	Type	Description	Qty	Part Number
1	Part	#10-24 X 1" hex socket head machine screw	20	09-9137
2	Part	Cam follower	10	02-0018
3	Part	$\frac{7}{16}$ " UNF thin nylock nut	10	09-5628
4	Part	Cam follower mounting bracket	10	1037-A-49
5	Part	Cam follower	50	1037-0-58
6	Part	$\frac{7}{8}$ " lock washer	50	09-5122
7	Part	$\frac{7}{8}$ " UNF hex jam nut	50	09-1489



**ILLUSTRATION 5.18: MANUAL SHIFTER ASSEMBLY EXPLODED**

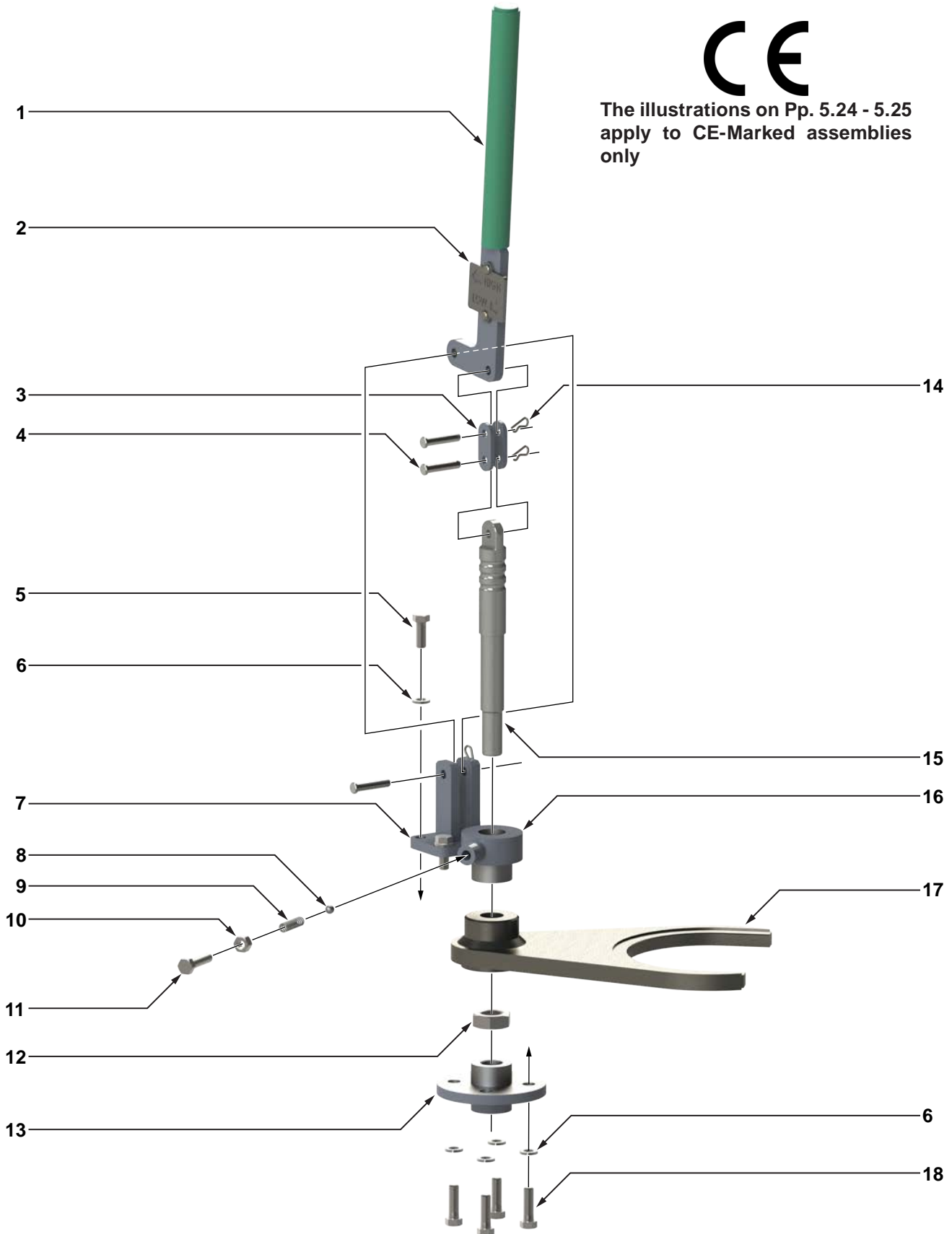


**ILLUSTRATION 5.19: MANUAL SHIFTER ASSEMBLY**

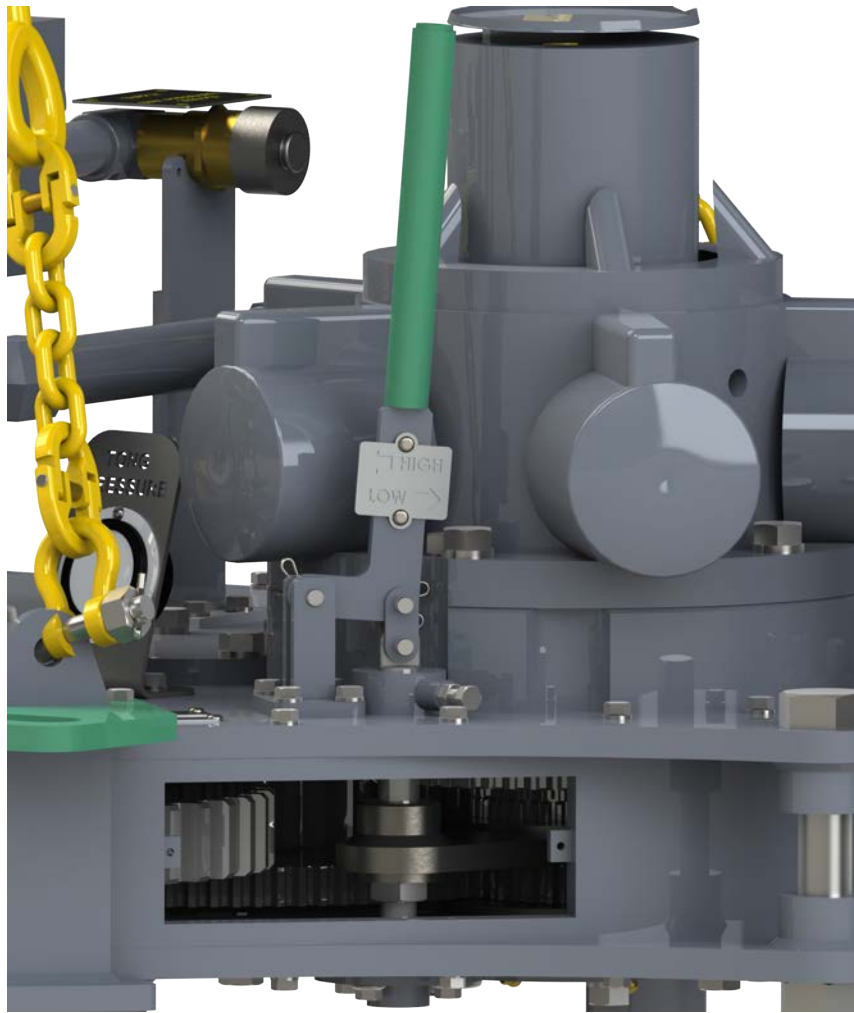
Item	Type	Description	Qty	Part Number
1	Part	Shifting lever weldment	1	1037-D-20B
2	Part	$\frac{5}{16}$ " x 1- $\frac{1}{2}$ " clevis pin	3	09-0256
3	Part	Shifting link	2	02-0120
4	Part	0.093" x 1- $\frac{1}{8}$ " hitch pin	3	
5	Part	$\frac{7}{16}$ " UNF x 1- $\frac{1}{2}$ " hex bolt	1	09-1110
6	Part	$\frac{7}{16}$ " UNF hex nut	1	09-5908
7	Part	Detent spring	1	997-0-64
8	Part	Detent ball	1	02-0018
9	Part	Shifting shaft bushing weldment	1	1037-C-21
10	Part	Shifting shaft	1	1037-C-20A
11	Part	$\frac{3}{8}$ " UNC x 1" hex bolt	4	09-1170
12	Part	$\frac{3}{8}$ " lock washer	4	09-5106
13	Part	Shifter lug weldment	1	101-0016
14	Part	Shifting fork	1	1037-D-27
15	Part	$\frac{7}{8}$ " UNF hex jam nut	1	09-1489
16	Part	Bottom bushing (typically welded to bottom plate)	1	1037-C-21



The illustrations on Pp. 5.24 - 5.25 apply to CE-Marked assemblies only



**ILLUSTRATION 5.20: MANUAL SHIFTER ASSEMBLY EXPLODED (CE-MARKED)**



**ILLUSTRATION 5.21: MANUAL SHIFTER ASSEMBLY (CE-MARKED)**

Item	Type	Description	Qty	Part Number
1	Weldment	Shifting lever weldment	1	101-5780
2	Part	Shifter label	1	101-5781
3	Part	Shifting link	2	02-0120
4	Part	$\frac{5}{16}$ " x 1- $\frac{1}{2}$ " clevis pin	3	09-0256
5	Part	$\frac{3}{8}$ " UNC x 1" hex bolt	4	09-1170
6	Part	$\frac{3}{8}$ " lock washer	8	09-5106
7	Weldment	Shifter lug weldment	1	101-3757
8	Part	Detent ball	1	02-0018
9	Part	Detent spring	1	997-0-64
10	Part	$\frac{7}{16}$ " UNF hex nut	1	09-5908
11	Part	$\frac{7}{16}$ " UNF x 1- $\frac{1}{2}$ " hex bolt	1	09-1110
12	Part	$\frac{7}{8}$ " UNF hex Jam nut	1	09-1489
13	Part	Bottom bushing	1	1037-C-21B
14	Part	0.093" x 1- $\frac{1}{8}$ " hitch pin	3	
15	Part	Shifting shaft	1	1037-C-20A
16	Weldment	Top shifter bushing weldment	1	1037-C-21
17	Part	Shifting fork	1	1037-D-27
18	Part	$\frac{3}{8}$ " UNC x 1- $\frac{1}{4}$ " hex bolt	4	09-1048

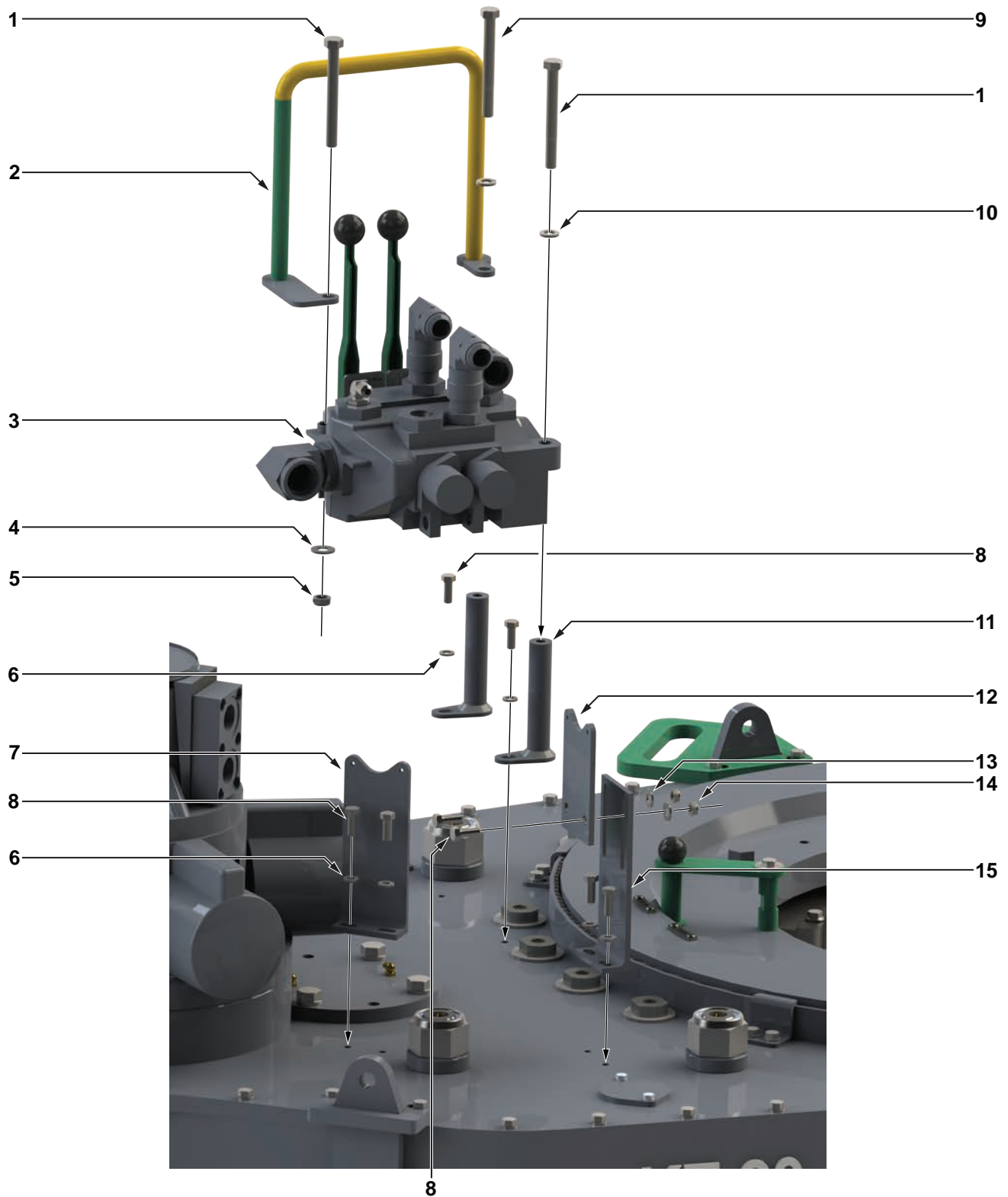


ILLUSTRATION 5.22: HYDRAULIC VALVE MOUNTS



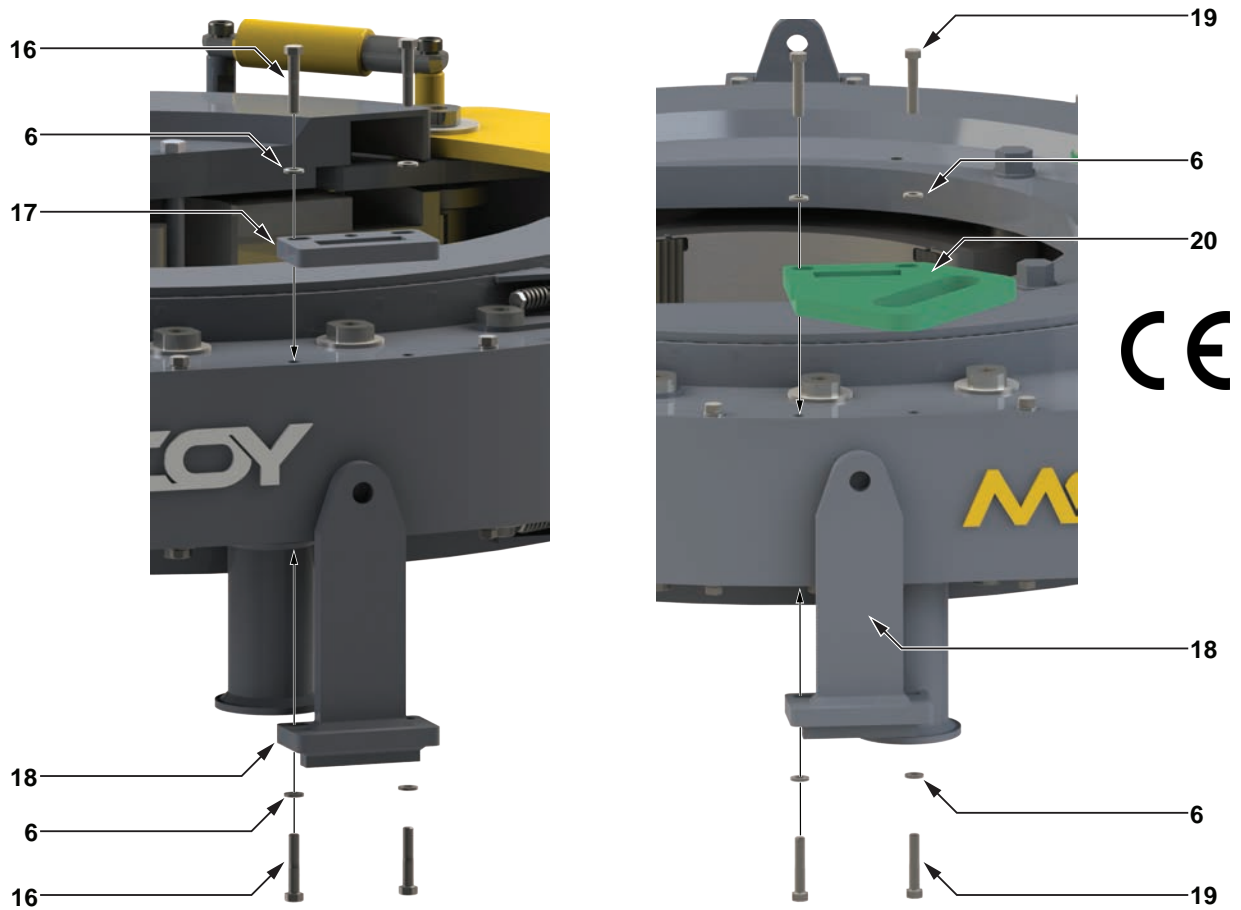


ILLUSTRATION 5.23: TONG HANGERS

Item	Type	Description	Qty	Part Number
1	Part	½" UNC x 4-½" hex bolt (CE-marked tongs only)	2	09-1184
2	Weldment	Hydraulic valve handle guard (CE-marked tongs only)	1	CE-HANDLE-2
3	Assembly	DVA hydraulic valve assembly (see Pp. 2.10 - 2.14)	1	
4	Part	½" narrow flat washer (CE-marked tongs only)	1	09-5119
5	Part	½" thin nylock nut (CE-marked tongs only)	1	09-5610S
6	Part	⅜" lock washer	22	09-5106
7	Weldment	Hydraulic discharge line support	1	101-2404
8	Part	⅜" UNC x 1" hex bolt	8	09-1170
9	Part	½" UNC x 5" hex bolt (CE-marked tongs only)	1	09-1186
10	Part	½" lock washer	2	09-5110
11	Weldment	Hydraulic valve support post weldment	2	101-1442
12	Part	Adjustable Inlet line support plate	1	101-0022
13	Part	⅜" Narrow flat washer	2	09-5124
14	Part	⅜" thin nylock nut	2	
15	Weldment	Hydraulic Inlet line support	1	101-1138
16	Part	⅜" UNC x 2" hex bolt	16	09-1054
17	Part	Hanger plate (Only used on RH side on CE-marked tongs)	4	101-4006
18	Weldment	Hanger weldment	4	101-3985
19	Part	⅜" UNC x 2" hex bolt, SS drilled (CE-marked tongs only)	16	09-1054SSD
20	Part	Hanger plate / handle (replaces item "S" on LH side of CE-marked tongs)	2	101-4006

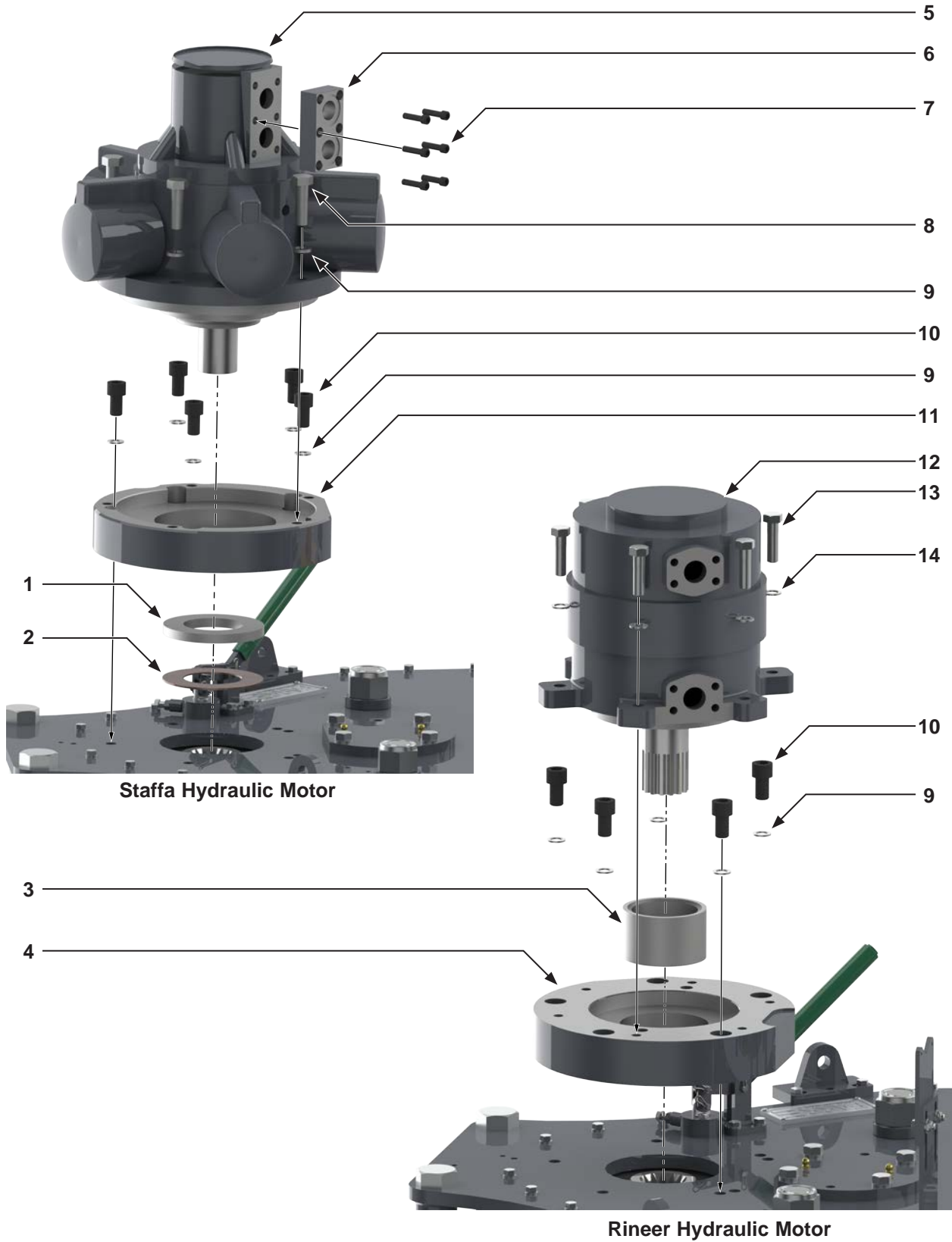


ILLUSTRATION 5.24: HYDRAULIC MOTOR ASSEMBLIES EXPLODED

Item	Type	Description	Qty	Part Number
1	Part	Upper motor spacer	1	1037-D-38S
2	Part	Thrust washer	1	101-3289
3	Part	Top clutch shaft spacer	1	1037-42
4	Part	Motor mount (Rineer)	1	1426-7
5	Part	Staffa hydraulic motor	1	87-0210B
6	Part	Staffa manifold block	1	87-0209
7	Part	3/8" UNC x 1-1/2" hex socket head cap screw	6	09-2051
8	Part	3/4" UNC x 2-1/2" hex bolt	5	09-1296
9	Part	3/4" lock washer	15	09-5118
10	Part	3/4" UNC x 1-1/4" hex socket head cap screw	10	09-2288
11	Part	Motor mount (Staffa)	1	1037-D-7
12	Part	Rineer hydraulic motor	1	87-0150
13	Part	5/8" UNC x 2-1/4" hex bolt	6	09-1235
14	Part	5/8" lock washer	6	09-5114

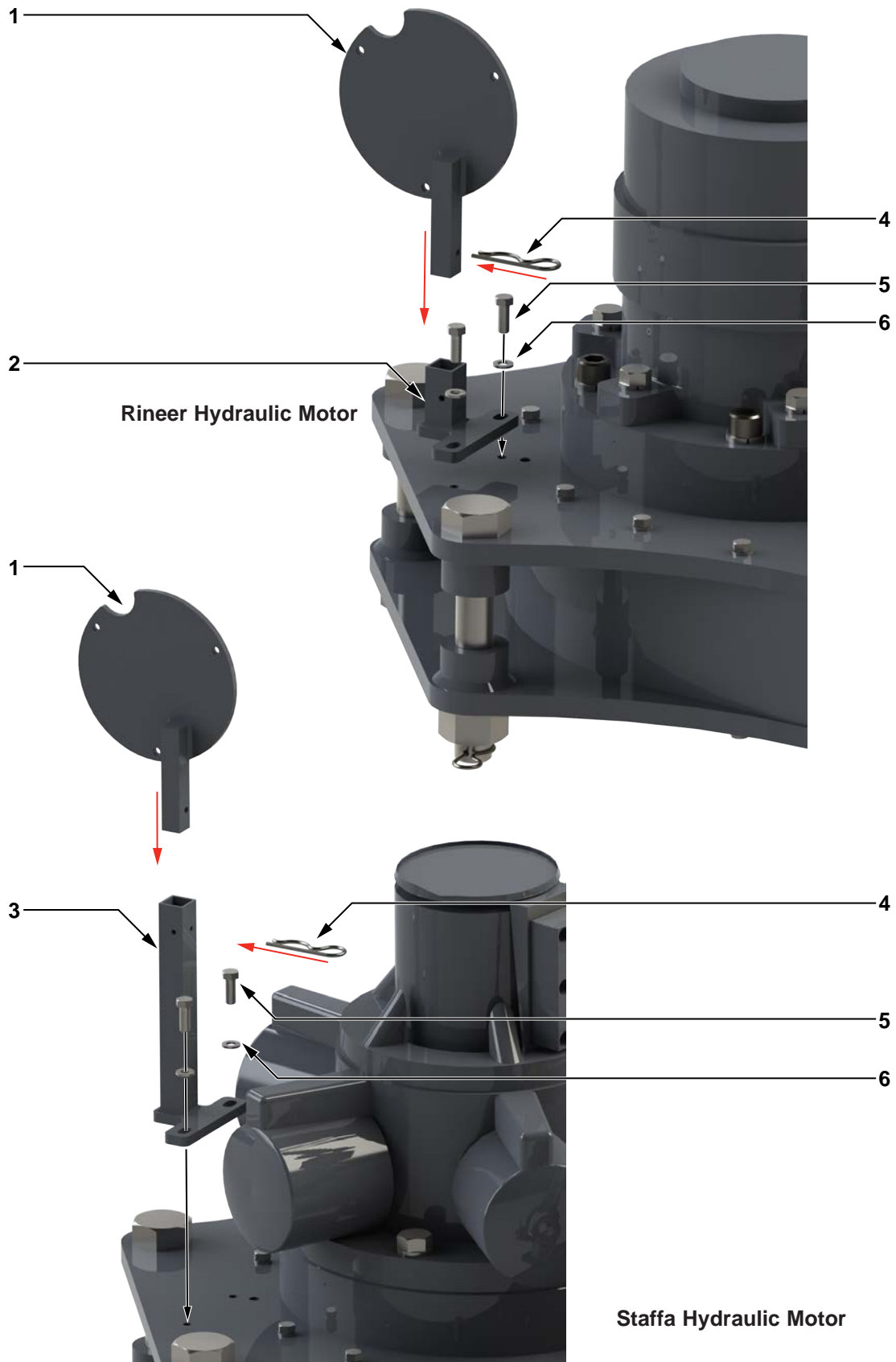
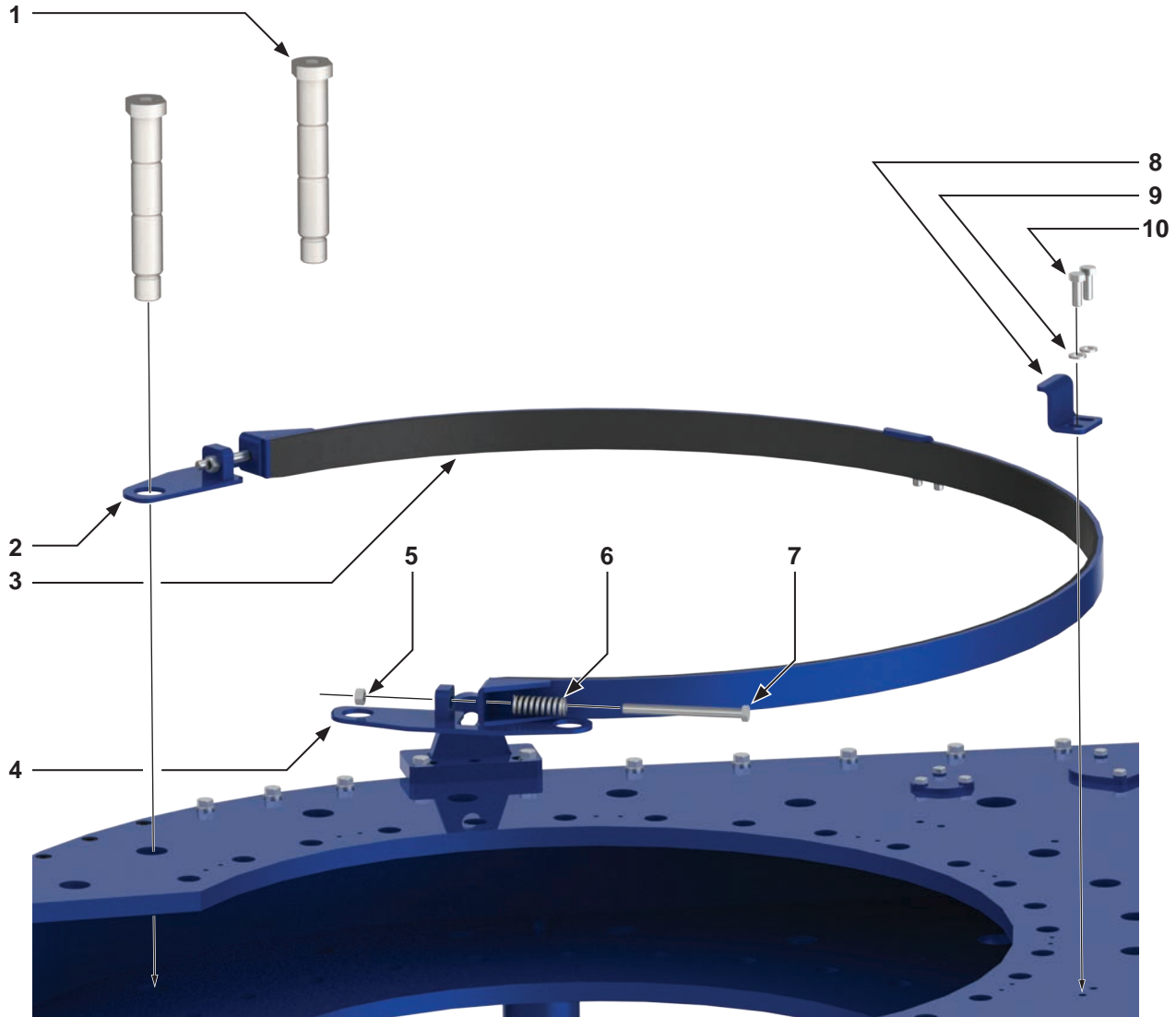


ILLUSTRATION 5.25: TORQUE GAUGE MOUNTS

Item	Type	Description	Qty	Part Number
1	Weldment	Torque gauge mount	1	1500-09-03A
2	Weldment	Torque gauge mount holder (Rineer motor)	1	101-0480
3	Weldment	Torque gauge mount holder (Staffa motor)	1	101-4465
4	Part	HITCH PIN .148 X 2.938	1	
5	Part	$\frac{3}{8}$ " UNC x 1- $\frac{1}{4}$ " hex bolt	2	09-1048
6	Part	$\frac{3}{8}$ " lock washer	2	09-5106



**ILLUSTRATION 5.26: BRAKE BANDS EXPLODED**



ILLUSTRATION 5.27: BRAKE BANDS

Item	Type	Description	Qty	Part Number
1	Part	Support roller shaft (shown for illustration purposes only)	4	101-3939
2	Weldment	Brake band lug weldment (RH top, LH bottom)	2	101-1636
3	Weldment	Brake band weldment (lined)	2	1037-D-63
4	Weldment	Brake band lug weldment (LH top, RH bottom)	2	101-1637
5	Part	$\frac{3}{8}$ " UNC hex nylock nut	4	09-5607
6	Part	Brake band spring	4	08-9264
7	Part	$\frac{3}{8}$ " UNC x 4- $\frac{1}{2}$ " hex bolt	4	09-1064
8	Part	Brake band retainer	4	101-1631
9	Part	$\frac{3}{8}$ " Regular carbon steel lock washer	8	09-5106
10	Part	$\frac{3}{8}$ " UNC x 1" hex bolt	8	09-1170



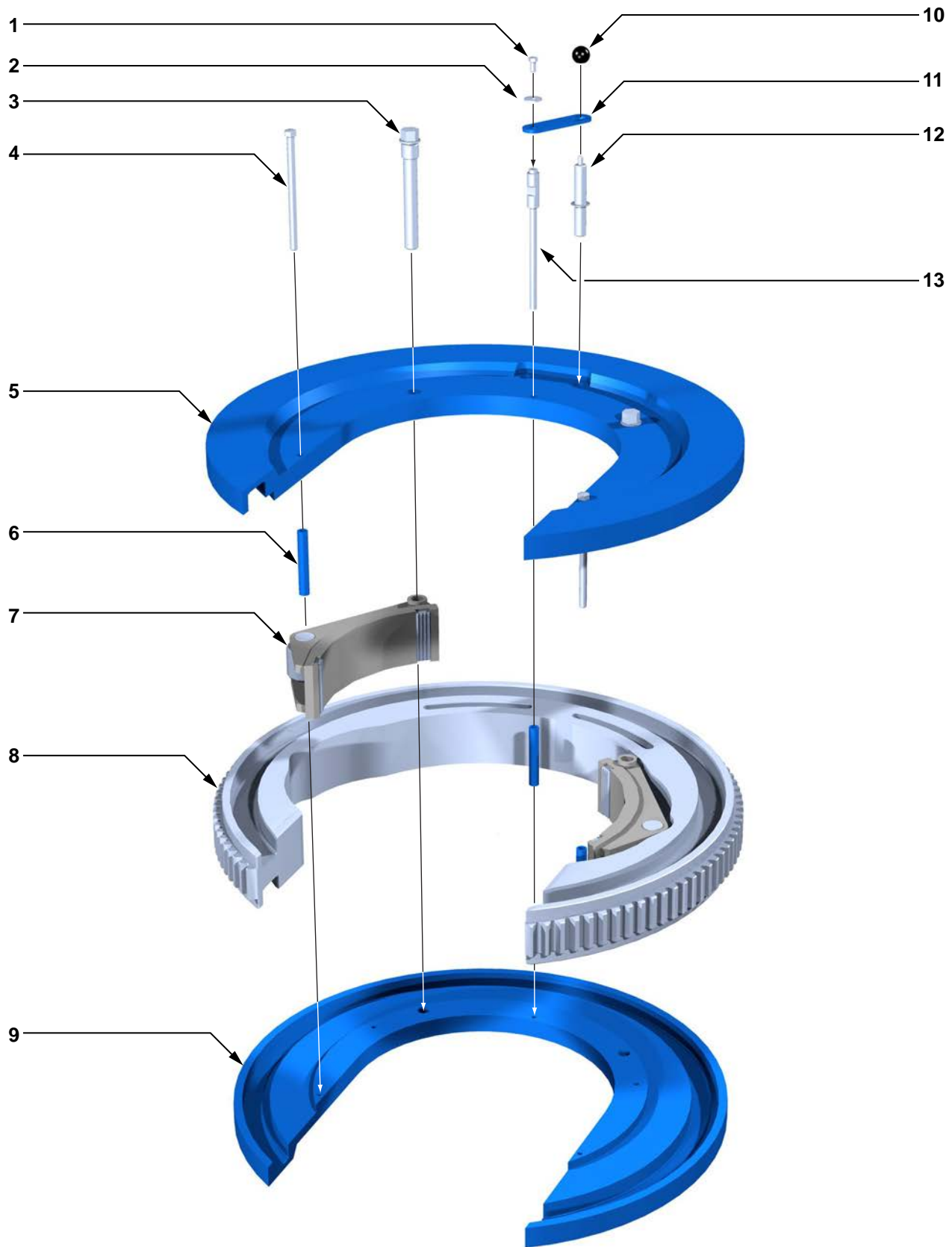


ILLUSTRATION 5.28: CAGE PLATE EXPLODED

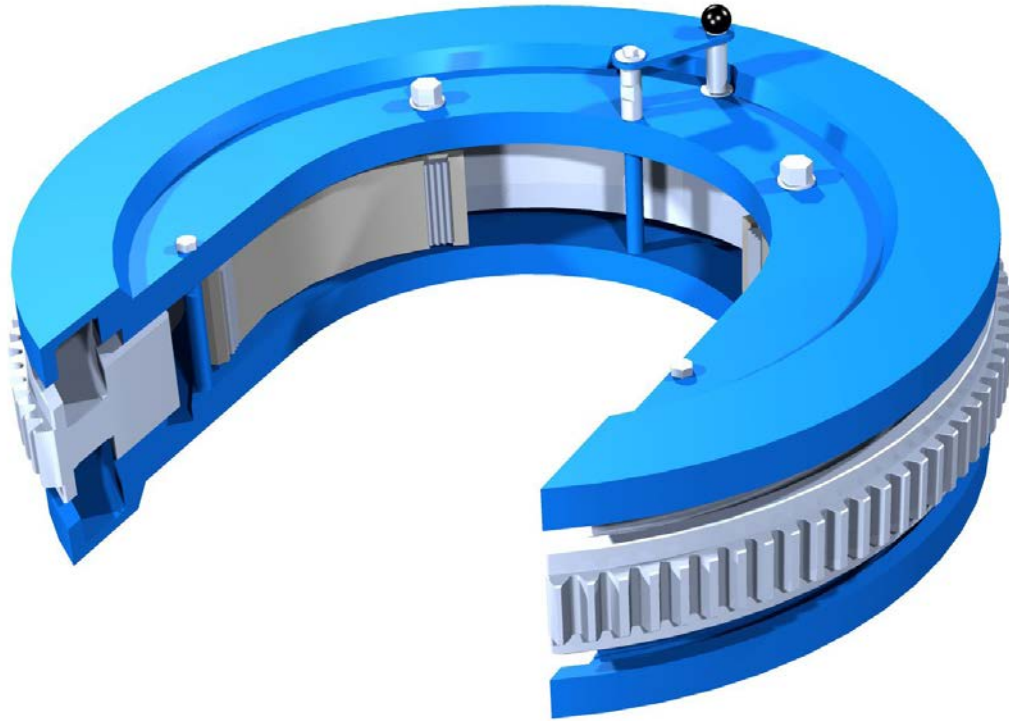


ILLUSTRATION 5.29: CAGE PLATE

Item	Type	Description	Qty	Part Number
1	Part	3/8" UNC x 3/4" hex bolt	1	09-1044
2	Part	3/8" plain washer	1	09-5006
3	Part	Jaw pivot bolt	2	1050-C5-28
4	Part	1/2" UNC x 8" hex bolt	2	09-1198
5	Part	Top cage plate	1	101-1580
6	Part	Cage plate spacer	3	1037-C-38
7	Assembly	Jaw Die Kit (20" shown - See Pg. 2.12)	2	
8	Part	Rotary gear	1	1037-D-46
9	Part	Bottom cage plate	1	1037-D-51
10	Part	Backing pin knob	1	02-0017
11	Part	Backing pin retainer	1	1037-B-54-1
12	Part	Backing pin	1	1037-C-39A
13	Part	Rear cage plate bolt	1	1037-36

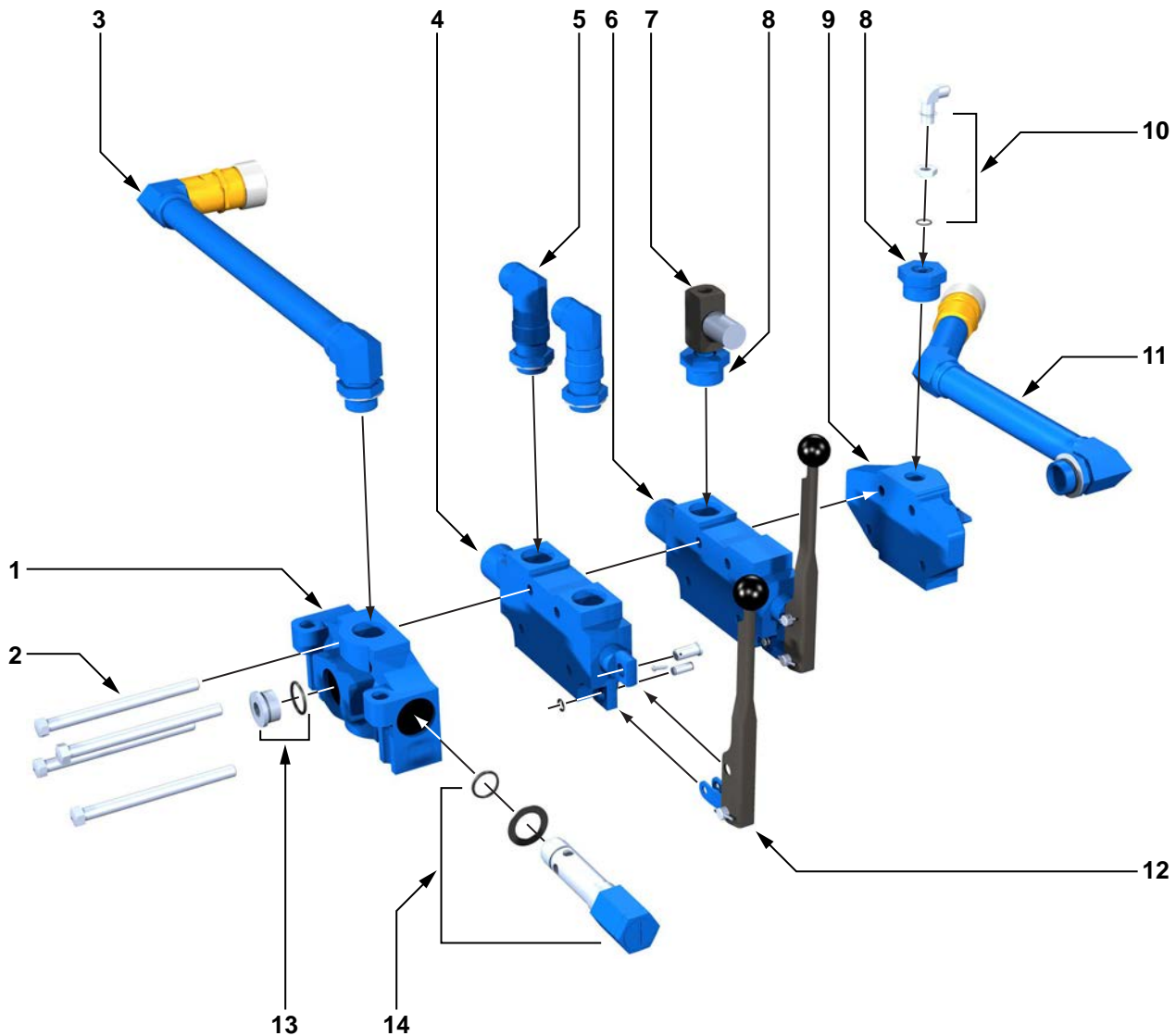
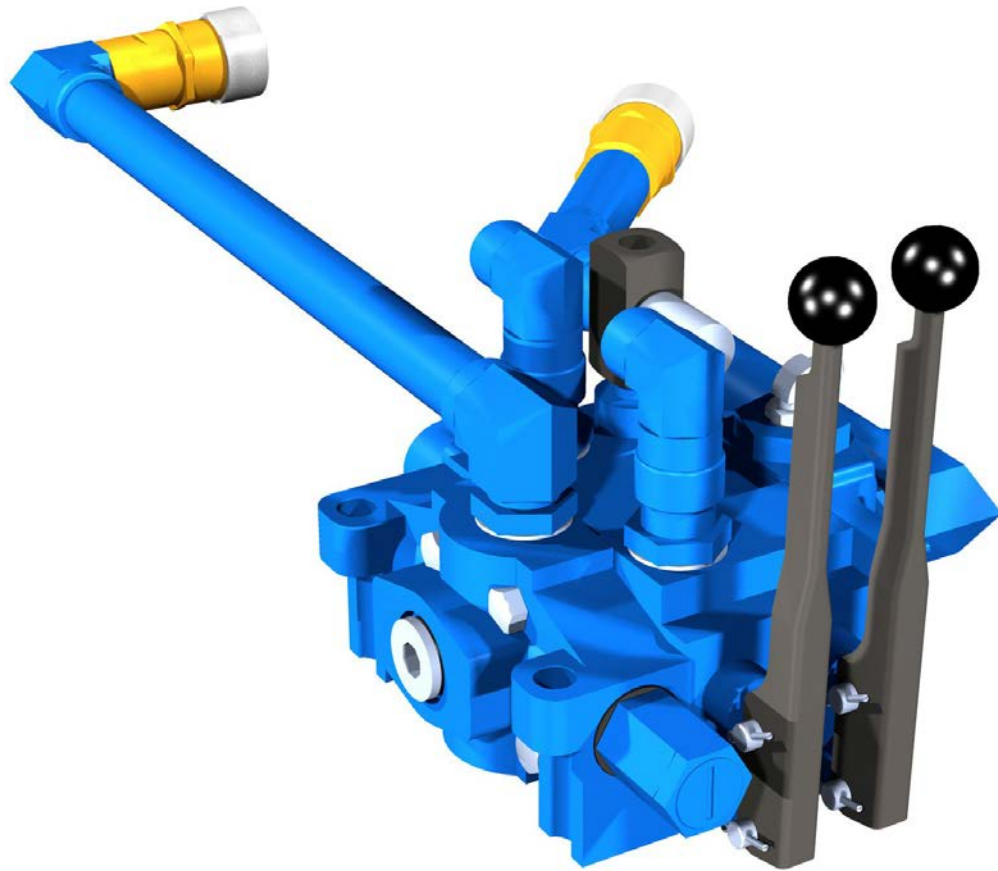


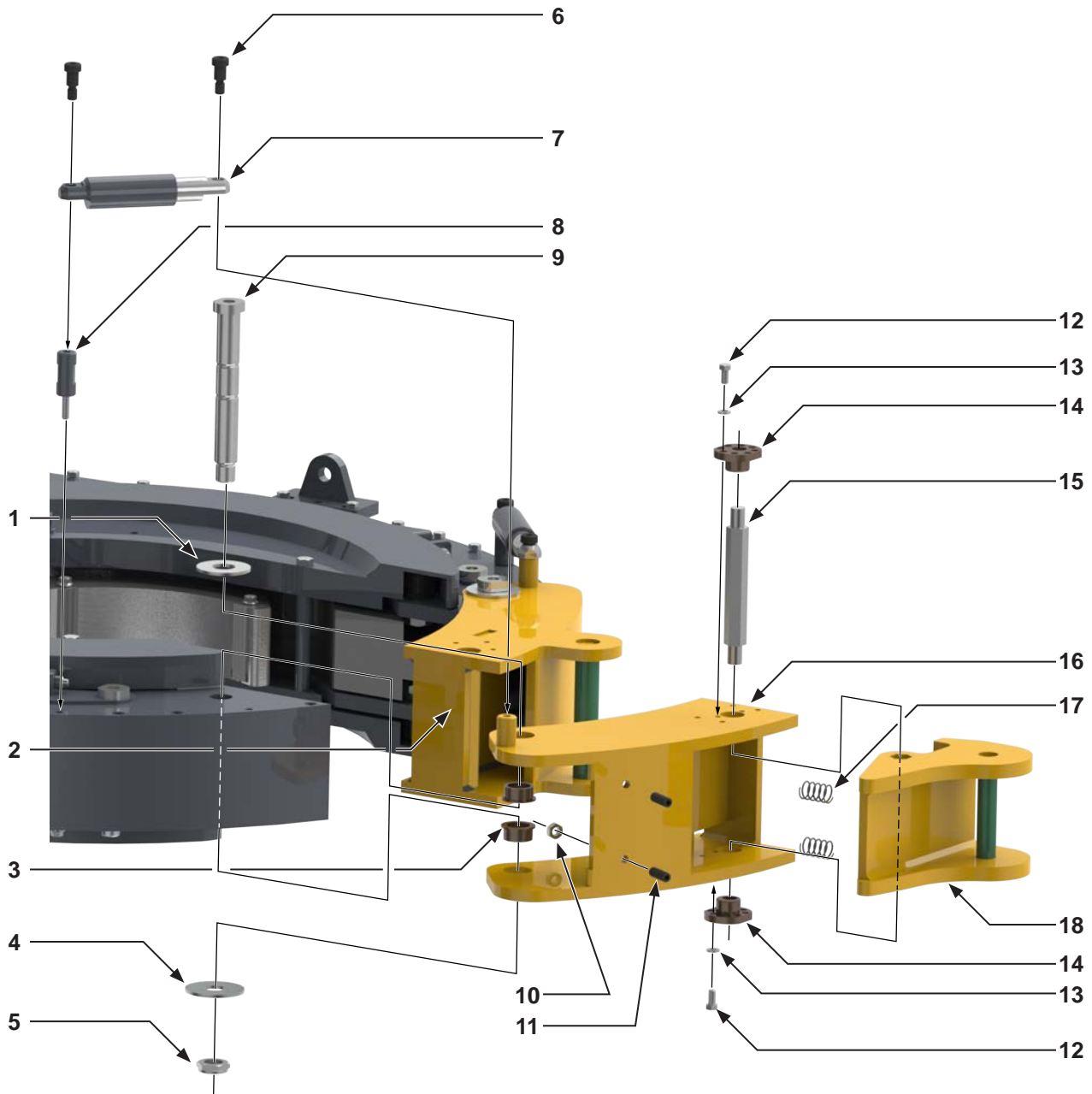
ILLUSTRATION 5.30: CONTROL VALVE ASSEMBLY EXPLODED

Item	Type	Description	Qty	Part Number
1	Part	Inlet valve	1	10-9016
2	Part	½" UNC x 6-½" hex bolt	4	09-1192
3	Assembly	1" hydraulic supply line (contains following parts)		
	Part	1" dust cap	1	02-9213
		1" quick-coupler fitting	1	02-9214
		1" MNPT/FNPT 90° fitting	1	02-9221
		1" NPT x 18" pipe nipple	1	NIPPLE-1-18
	Part	1" M-ORB/F-NPT 90° fitting	1	02-9210
4	Part	Directional valve, motor control, SAE port	1	10-9014
5	Part	M-ORB/JIC Long 90d 1" Fitting	2	02-9210
6	Part	Directional valve, lift cylinder control, SAE port (if equipped)	1	10-9015
7	Part	⅜" needle valve	1	08-9062
8	Part	#20 ORB - #8 ORB reducer bushing	2	10-9068
9	Part	Outlet valve	1	10-0086

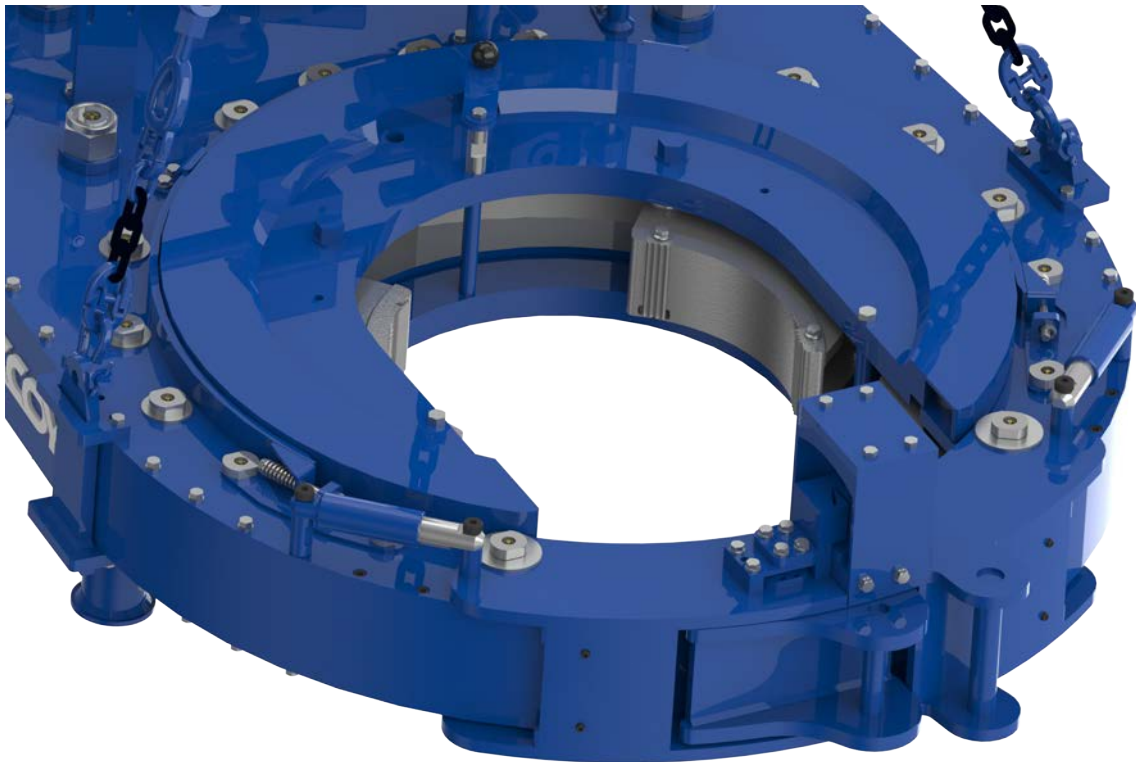


**ILLUSTRATION 5.31: CONTROL VALVE ASSEMBLY**

Item	Type	Description	Qty	Part Number
10	Part	3/8" ORB - 3/8" JIC 90° adapter	1	02-9200
11	Assembly	1-1/4" hydraulic discharge line (contains following parts)		
	Part	1-1/4" dust cap	1	02-9212
		1-1/4" quick-coupler fitting	1	02-9215
		1-1/4" MNPT- FNPT 45° fitting	1	
		1-1/4" NPT x 11" pipe nipple	1	NIPPLE-1250-11
		1-1/4" NPT x 4" pipe nipple	1	NIPPLE-1250-4
		1-1/4" ORB/FNPT 90° fitting	1	02-9202
12	Assembly	Hydraulic valve handle assembly (contains following parts)	2	01-0409
	Part	Hydraulic valve handle	1	01-0409-HANDLE
		Hydraulic valve handle links	1	01-0409-LINK
		Hydraulic valve pin #1	2	01-0409-PIN1
		Hydraulic valve pin #2	1	01-0409-PIN2
		C-clip	2	01-0409-CIRCLIP
		Cotter pin	2	01-0409-COTTER
13	Part	1" ORB plug	1	02-9222
14	Part	Hydraulic relief valve	1	10-0062



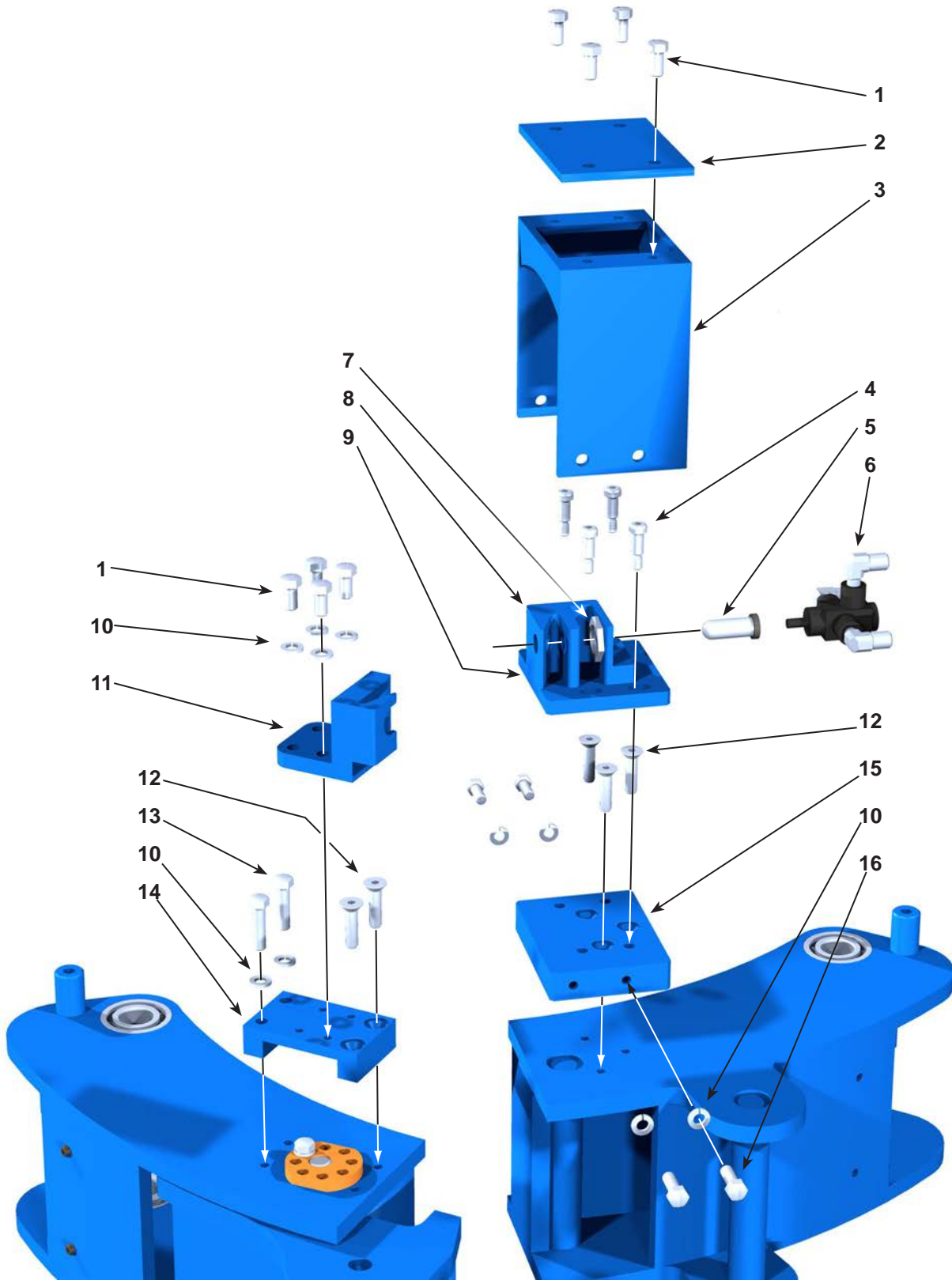
**ILLUSTRATION 5.32: DOOR ASSEMBLY EXPLODED**

**ILLUSTRATION 5.33: DOOR ASSEMBLY**

Item	Type	Description	Qty	Part Number
1	Part	1- $\frac{1}{8}$ " flat washer	2	09-5041
2	Weldment	LH Door weldment	1	1037-D43-142-RHA
3	Part	Door bushing	4	101-0110
4	Part	1" flat washer	2	09-5026
5	Part	1" UNS thin nylock nut (support roller)	4	09-9167
6	Part	$\frac{5}{8}$ " x $\frac{3}{4}$ " hex socket UNC shoulder bolt	4	09-0049
7	Assembly	Door cylinder assembly	2	1037-A4-144
8	Part	Door cylinder mounting lug	2	101-0446
9	Part	Door pivot roller shaft (support roller)	2	101-3940
10	Part	$\frac{1}{2}$ " UNC hex jam nut	4	09-5810
11	Part	$\frac{1}{2}$ " UNC x 1- $\frac{1}{2}$ " hex socket flat point set screw	4	
12	Part	$\frac{3}{8}$ " UNC x $\frac{3}{4}$ " hex bolt	2	09-2048
13	Part	$\frac{3}{8}$ " lock washer	2	09-5106
14	Part	Door latch cam	2	1037-C-151
15	Part	Door latch shaft	1	1037-C-200
16	Weldment	RH door weldment	1	1037-D43-142-LHA
17	Part	Door latch spring	2	997-16
18	Weldment	Latch weldment	1	101-1570

**See next page for safety door components**





**ILLUSTRATION 5.34: SAFETY DOOR COMPONENTS EXPLODED**



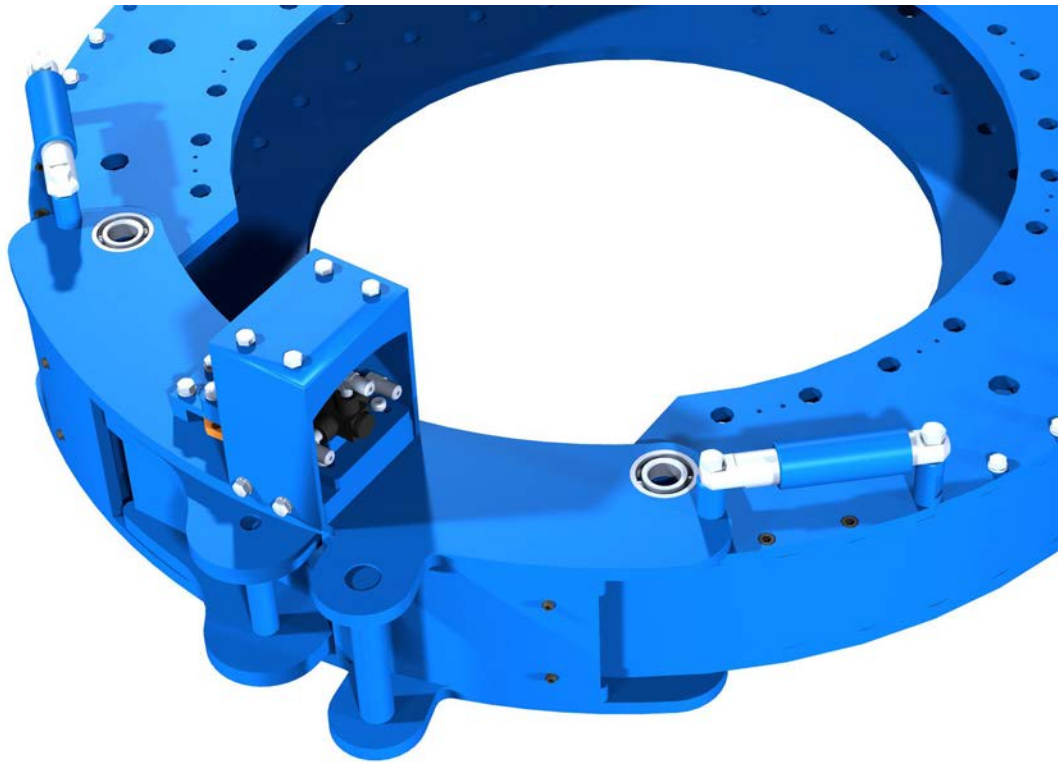


ILLUSTRATION 5.35: SAFETY DOOR COMPONENTS

Item	Type	Description	Qty	Part Number
1	Part	3/8" UNC x 3/4" hex bolt	8	09-1044
2	Part	Safety door plate	1	101-1238
3	Weldment	Safety door protector weldment	1	101-0450
4	Part	5/16" x 3/4" hex socket UNC shoulder bolt	4	09-0227
5	Part	Load plunger	1	AE12-306
6	Part	Safety door hydraulic switch	1	08-0337M
7	Part	15/16" valve lock nut	1	09-0278
8	Part	LH safety door latch block	1	AE13-301S
9	Part	LH safety door latch plate #2	1	AE13-311
10	Part	3/8" lock washer	6	09-5106
11	Part	RH safety door latch block	1	AE-13-302M
12	Part	3/8" UNC x 1-1/2" hex socket flat head countersunk screw	5	09-4050
13	Part	3/8" UNC x 1-1/2" hex bolt	2	09-1553
14	Part	RH safety door latch plate	1	101-0479
15	Part	LH safety door latch plate	1	101-0915
16	Part	3/8" UNC x 1" hex bolt	4	09-1170

**CE-Marked tongs use the following parts in place of those in the previous table:**

Item	Type	Description	Qty	Part Number
1	Part	3/8" UNC x 3/4" hex Bolt, SS, drilled for wire-ties	8	09-1044SSD
4	Part	5/16" x 3/4" hex socket UNC shoulder bolt, drilled for wire-ties	4	09-0227SSD
13	Part	3/8" UNC x 1-1/2" hex bolt, SS, drilled for wire-ties	2	09-1553SSD
16	Part	3/8" UNC x 1" hex bolt, SS, drilled for wire-ties	4	09-1170SSD

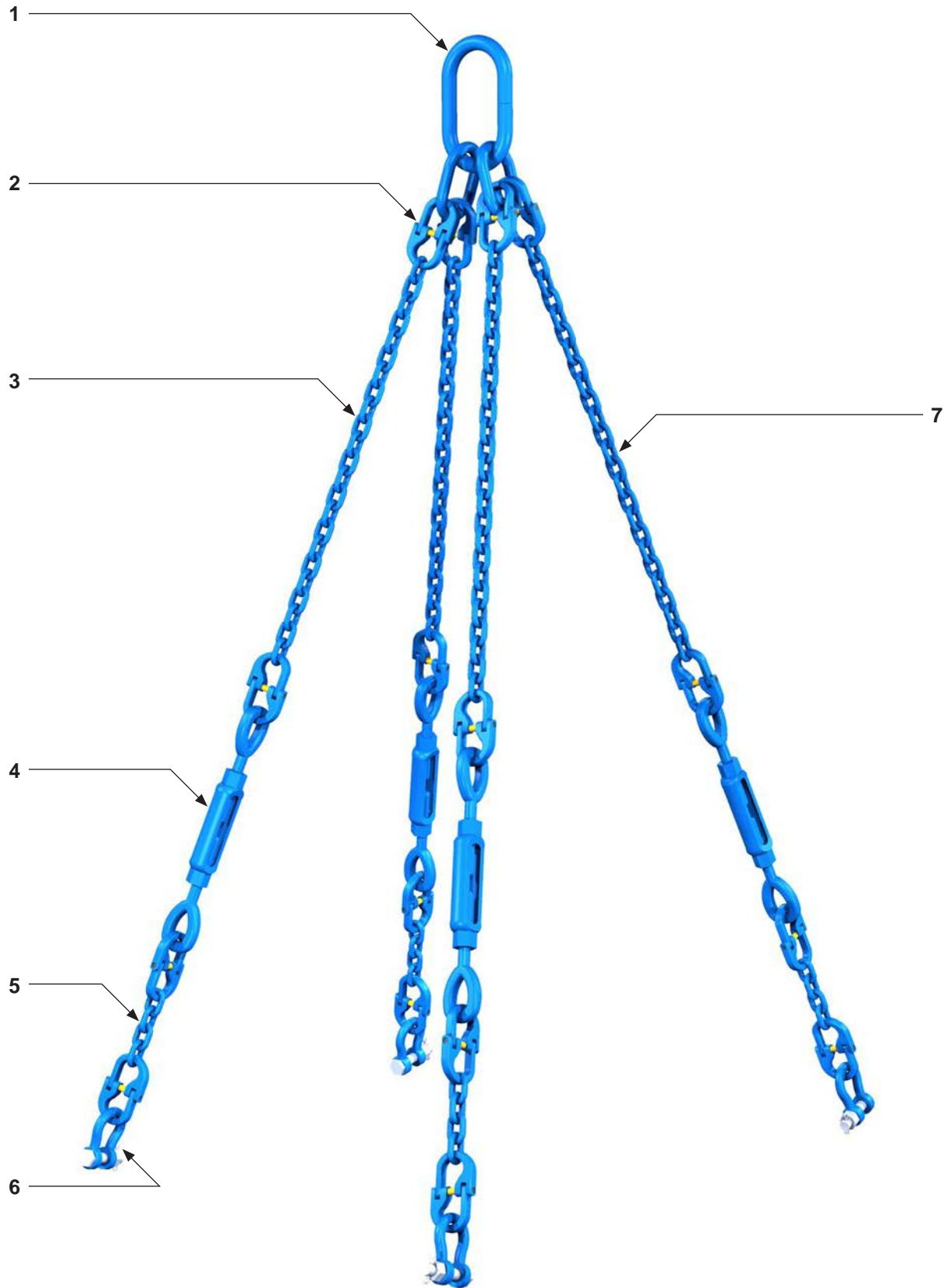


ILLUSTRATION 5.34: SAFETY DOOR COMPONENTS EXPLODED

Item	Type	Description	Qty	Part Number
1	Part	Master Link	1	02-0517
2	Part	Hammer Lock Connector (4 per chain)	16	02-0607
3	Part	23 Link Chain Set (Rear)	2	101-0376
4	Part	Turnbuckle	4	02-6506
5	Part	4 Link Chain Set	4	101-0378
6	Part	Shackle Assembly	4	02-9063
7	Part	25 Link Chain Set (Front)	2	101-0377



**ALL FASTENERS USED DURING REASSEMBLY OF LOAD-BEARING COMPONENTS (CHAIN SLINGS, RIGID SLINGS, BACKUP LEGS) MUST BE TIGHTENED TO THE CORRECT TORQUE. THREADED FASTENERS USED IN LOAD-BEARING DEVICES MUST BE SECURED WITH RED LOCTITE™. CHECK ALL CHAINS FOR DAMAGE BEFORE PLACING UNDER LOAD. DO NOT ALLOW CHAINS TO KINK BEFORE PLACING UNDER LOAD.**



**This page intentionally  
left blank**



SECTION 6: TORQUE MEASUREMENT



**This page intentionally  
left blank**

6.A BASIC TORQUE MEASUREMENT

Basic torque measurements are performed using a simple hydraulic measurement system. A hydraulic load cell connects to a calibrated torque gauge through a reinforced flexible hydraulic hose. The torque gauge is factory-calibrated to display accurate torque measurements for a tong or tong and backup assembly with a particular arm length. The arm length is a measurement from the centre of the pipe or casing to the centre of the force being applied to the load cell.

Two load cell options are available. A tension load cell is typically used with a suspended stand-alone tong. This application requires that the load cell be attached to the rear of the tong as part of the restraint line that opposes the force generated when the tong makes up or breaks out a joint. A compression load cell is used in a tong and backup assembly, and is typically located on the rear of the backup between the backup and a stationary frame. The load cell must be located in the centre of the compression force vector generated between the backup and the frame.

Hydraulic force generated by a load cell is transmitted to the torque gauge via a reinforced flexible hydraulic line. The hydraulic force is displayed as torque in units of Ft.-Lbs. The torque gauge has a red “peak torque” indicator that tracks with the torque gauge needle to the point of highest torque, and remains at the point of highest torque until manually reset. Note that every model of tong and tong and backup assembly has a unique arm length, and the torque gauge must be calibrated for that arm length. Torque gauges that are not calibrated for the arm length of the tool in service will not display correct torque. To ensure correct torque measurement, ensure the arm length or “handle” as displayed on your torque gauge matches the arm length of the tool in service as listed on the specifications page of the technical manual.

The images on this page are for illustration purposes only and may not accurately represent the torque gauge and load cell that have been supplied with your equipment.



THE IMAGES DISPLAYED ARE SUPPLIED FOR ILLUSTRATION PURPOSES ONLY



**ILLUSTRATION 6.A.1: TORQUE GAUGE (FOR ILLUSTRATION PURPOSES ONLY)**



**ILLUSTRATION 6.A.2: TENSION LOAD CELL**



**ILLUSTRATION 6.A.3: COMPRESSION LOAD CELL**

Torque gauges and load cells are supplied as a matched calibrated pair. Substituting one or the other will render the calibration inaccurate even if the actual model numbers appear to be identical. The serial numbers of matching load cell and torque gauges are clearly identified on the calibration certificate. Should you suspect the accuracy of your torque measurements, or wish to replace either component the pair should be returned to the factory for re-calibration before placing into service.



**TORQUE GAUGES AND LOAD CELLS ARE FACTORY-SUPPLIED SUPPLIED AS MATCHED CALIBRATED PAIRS. IF REPLACING EITHER COMPONENT THE LOAD CELL AND TORQUE GAUGE MUST BE RETURNED TO THE FACTORY FOR RE-CALIBRATION BEFORE PLACED INTO SERVICE.**



**6.A BASIC TORQUE MEASUREMENT (CONTINUED):**

The images on the preceding page are for illustration purposes only and may not accurately represent the torque gauge and load cell that have been supplied with your equipment. Please note that the parts listed in the following table are correct for accurate torque measurement while using the equipment for which this manual is supplied.



**THE TORQUE GAUGE USED IS FULLY DEPENDANT UPON THE ARM LENGTH AND TORQUE RANGE OF THE EQUIPMENT IN USE. THE PART NUMBERS LISTED IN THE FOLLOWING TABLE ARE CORRECT FOR ACCURATELY MEASURING TORQUE USING THE EQUIPMENT FOR WHICH THIS MANUAL IS SUPPLIED.**

Item	Type	Description	Qty	Part Number
	Assembly	52" Arm - 60K Torque Gauge / Compression Load Cell Assembly	1	10-0023T
1	Part	52" Arm 60,000 Ft.-Lbs.Torque Gauge	1	10-0023G
2	Part	Tension Load Cell	1	10-0008T
3	Part	Hydraulic Hose	1	02-0069
4	Part	Torque Gauge Flange	1	997-D7-5
5	Part	Tension Load Cell Shackle	1	02-0078



**LOAD CELLS ARE NOT USER SERVICEABLE. ILLUSTRATION 6.A.4 IS PROVIDED FOR INFORMATION PURPOSES ONLY. DAMAGED LOAD CELLS MUST BE RETURNED TO THE FACTORY FOR REPAIR AND RE-CALIBRATION.**

**ELECTRONIC LOAD CELLS ARE NOT PERMITTED FOR USE WITH CE MARKED EQUIPMENT**

Item	Type	Description
	Assembly	Tension Load Cell, 4.08 in <sup>2</sup>
1	Part	1/4" NC x 1/2" Binding Head Machine Screw
2	Part	Stat-O-Seal
3	Part	O-Ring
4	Part	O-Ring
5	Part	Load Cell Piston
6	Part	Flange Gasket
7	Part	Load Cell End
8	Part	Load Cell Rod
9	Part	Wiper
10	Part	O-Ring
11	Part	Load Cell Body
12	Part	3/8" NC x 3/8" Cup Point Hex Set Screw
	Seal Kit	Replacement Seal Kit 4.08 in <sup>2</sup> Tension Load Cell

This is the standard tension load cell supplied by McCoy Drilling & Completions | Farr. Contact our sales department for information about optional application-specific tension load cells.

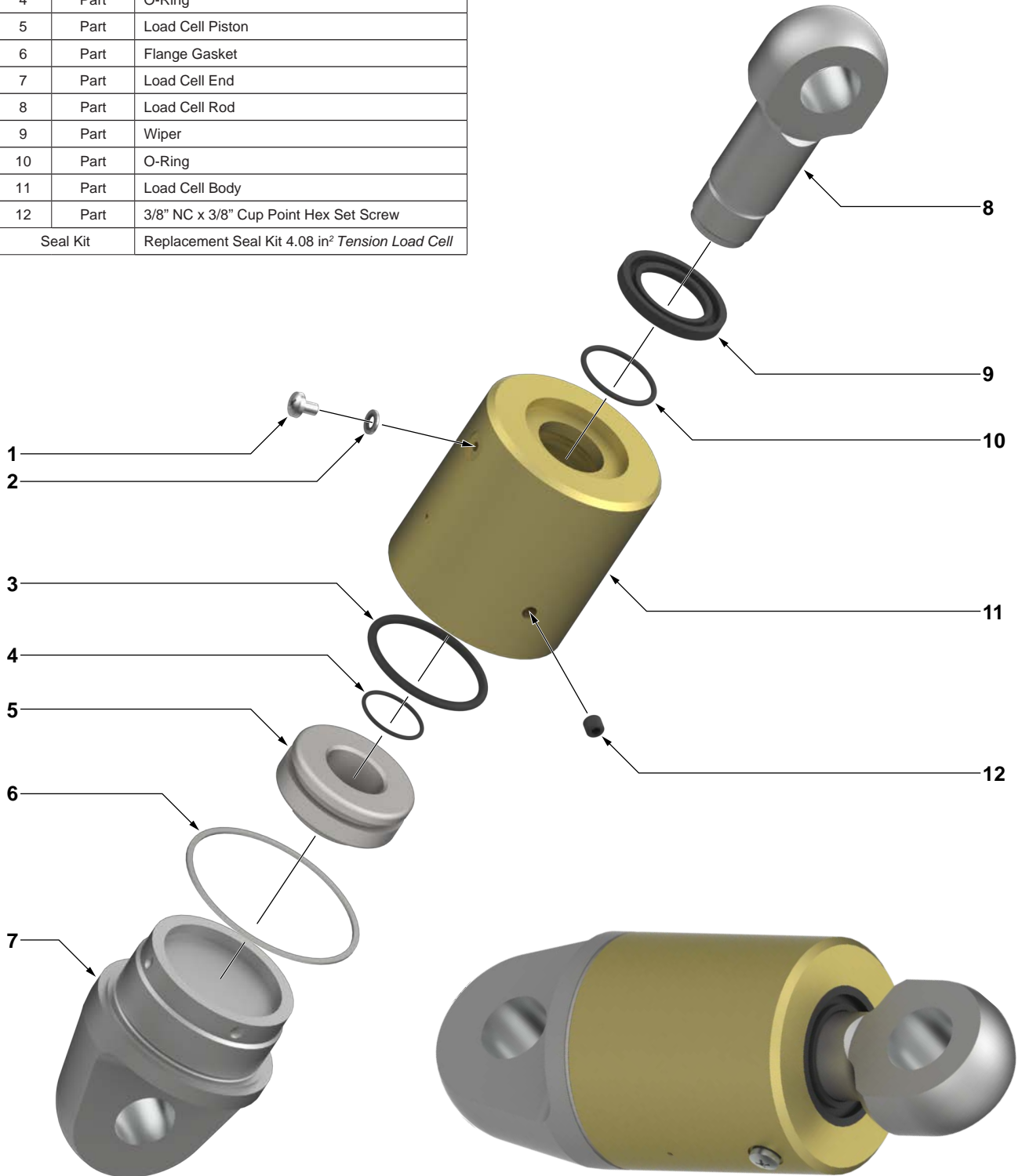
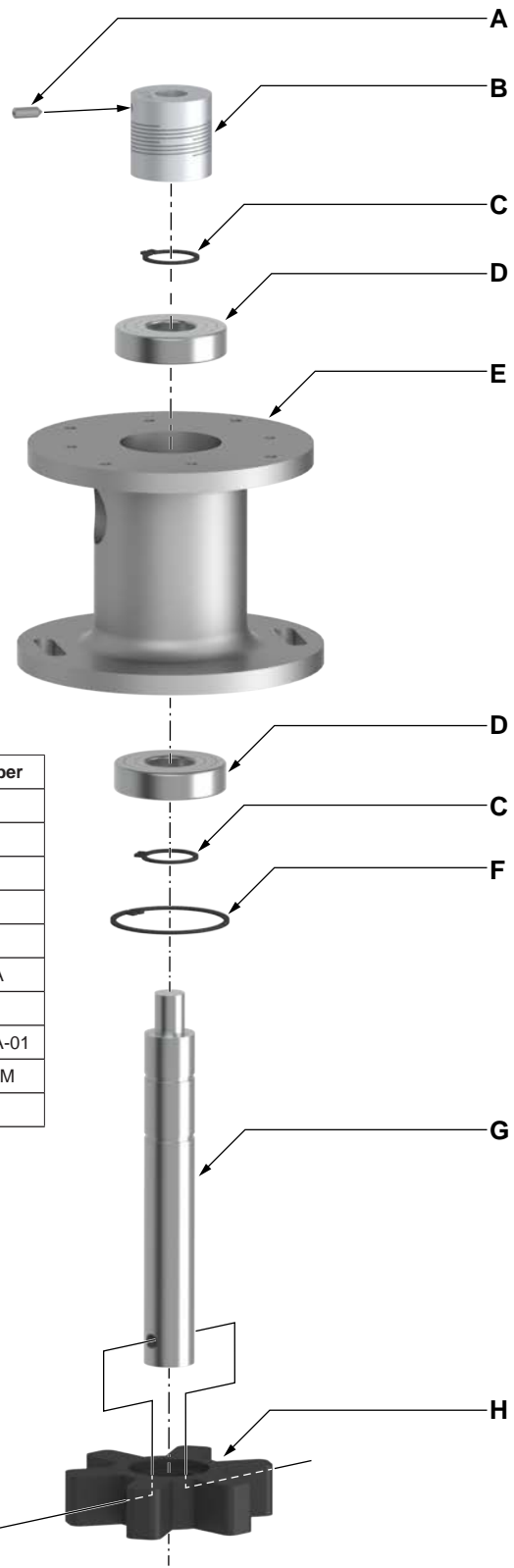
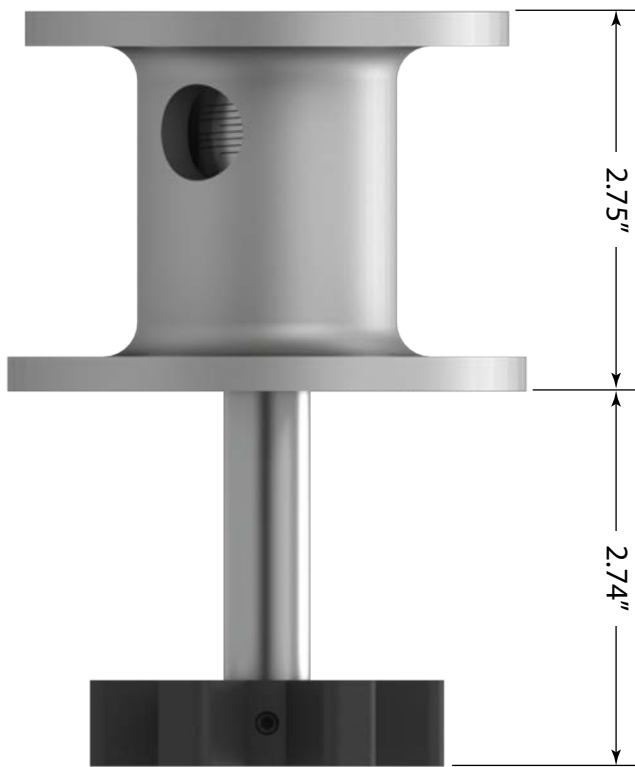


ILLUSTRATION 6.A.4: TENSION LOAD CELL EXPLODED



Item	Type	Description	Qty	Part Number
	Assembly	Standard Turn Counter Encoder Mount	1	60-0001
A	Part	6-32 x 3/8" Hex Socket Head Set Screw	4	
B	Part	Helical Flexible Encoder Shaft Coupling	1	60-0130N
C	Part	Internal Retainer Ring	2	1376-13
D	Part	Bearing	2	1376-05
E	Part	Encoder Housing	1	1392-104A
F	Part	Internal Retainer Ring	1	02-0436
G	Part	Encoder Shaft	1	1392-103A-01
H	Part	Encoder Gear	1	01-0320A-M
J	Part	10-24 x 1-1/4" Hex Socket Head Set Screw	1	

ILLUSTRATION 6.A.5: TURN COUNTER ENCODER MOUNT EXPLODED

6.B TROUBLESHOOTING

Under normal operating conditions, and with proper maintenance, the torque gauge and load cell system are designed to give lasting trouble-free performance. Faulty indication on the gauge will very often define a fault within the gauge.



**IF TROUBLESHOOTING REVEALS THAT THERE IS INSUFFICIENT FLUID IN THE SYSTEM, BEFORE RECHARGING, CHECK THAT ALL SYSTEM COMPONENTS ARE FREE FROM DAMAGE. THIS WILL ENSURE THAT FLUID LOSS WILL NOT CONTINUE AFTER RELOADING**

1 SYMPTOM: NO INDICATION ON TORQUE GAUGE	
POSSIBLE PROBLEM	SOLUTION(S)
Hydraulic hose is obstructed	Check hydraulic hose for kinks
	Replace hydraulic hose
Loss of hydraulic fluid	Recharge hydraulic fluid (see Section 6.C). NOTE: Ensure any breaches in the hydraulic system between the load cell and torque gauge are repaired to prevent further fluid loss.
Internal mechanism of torque gauge is damaged	Replace gauge
2 SYMPTOM: GAUGE INDICATION UNEXPECTEDLY HIGH	
POSSIBLE PROBLEM	SOLUTION(S)
Excessive hydraulic fluid	Completely drain hydraulic fluid from torque gauge/load cell system. Recharge following the procedure in Section 6.C
Internal mechanism of gauge is damaged	Replace gauge
Incorrect torque gauge in use (not part of the original torque gauge/load cell pair)	Replace gauge with gauge properly calibrated for the load cell in service
3 SYMPTOM: GAUGE INDICATION UNEXPECTEDLY LOW	
POSSIBLE PROBLEM	SOLUTION(S)
Insufficient hydraulic fluid	Recharge hydraulic fluid (see Section 6.C). NOTE: Ensure any breaches in the hydraulic system between the load cell and torque gauge are repaired to prevent further fluid loss
	Check hydraulic hose for kinks
Obstruction in hydraulic hose	Replace hydraulic hose
Snub line not at right-angle to tong handle	Check angle of snub line and correct if necessary
Internal mechanism of gauge is damaged	Replace gauge
Incorrect torque gauge in use (not part of the original torque gauge/load cell pair)	Replace gauge with gauge properly calibrated for the load cell in service
4 SYMPTOM: GAUGE INDICATION IS ERRATIC OR SLUGGISH	
POSSIBLE PROBLEM	SOLUTION(S)
Insufficient hydraulic fluid in torque measurement section	Recharge hydraulic fluid (see Section 6.C). NOTE: Ensure any breaches in the hydraulic system between the load cell and torque gauge are repaired to prevent further fluid loss
Loss of damping fluid in torque gauge	Top up or refill damping fluid (NOTE: Ensure leakage points in gauge are identified and repaired to prevent further loss of damping fluid)
Air bubbles in hydraulic fluid in the torque measurement system	Bleed air from load cell and torque gauge and top up fluid (if necessary) as per Section 6.C
Internal mechanism of gauge is damaged	Replace gauge

## 6.C PERIODIC INSPECTION AND MAINTENANCE



**ONLY QUALIFIED, DESIGNATED PERSONNEL ARE PERMITTED TO PERFORM MAINTENANCE ON THE TORQUE MEASUREMENT SYSTEM.**

## 6.C.1 Inspection

The torque measurement system supplied with your equipment is designed and built to provide years of trouble-free service with minimum maintenance. Periodic inspections of the load cell, hydraulic lines and fittings are recommended in order to keep the system in top operating condition. A thorough inspection should be made at each rig-up.

## 6.C.2 Fluid Recharge

Recharge hydraulic system with W15/16 fluid through the check valve on the torque indicating gauge. Recharging must only be performed when there is no load on the load cell. Refer to the illustrations on pages 6.3 & 6.4 for guidance if required.

- a. Place the torque indicating gauge higher than the load cell. Remove the brass 1/4" cap from the fitting on the check valve on the top of the gauge.
- b. Connect the hand pump to the check valve fitting.
- c. Elevate the load cell so it is higher than the torque gauge and hand pump.



**UN-CONTAINED SPILLAGE OF THE HYDRAULIC FLUID IN THIS SYSTEM MAY CONTRAVENE GOVERNMENTAL ENVIRONMENTAL REGULATIONS, OR THE ENVIRONMENTAL REGULATIONS AND POLICIES OF YOUR COMPANY. FARR CANADA CORP. HIGHLY RECOMMENDS PLACING YOUR LOAD CELL IN A CONTAINMENT BASIN BEFORE PROCEEDING WITH THE BLEEDING & REFILLING PROCESS.**

- d. Fill hand pump bowl with W15/16 hydraulic fluid.



**MAINTAIN GREATER-THAN HALF FULL FLUID LEVEL IN THE HAND PUMP BOWL TO AVOID PUMPING AIR INTO THE SYSTEM. DO NOT ALLOW THE LEVEL TO FALL BELOW ONE-HALF FULL**

- e. Remove the vent plug screw and Stat-O-Seal (Items C and D on Illustration 6.A.4, or item H on Illustration 6.A.5) to allow trapped air to escape.
- f. Pump fluid into the system until no more air is seen escaping from the vent port.
- g. Replace the vent plug screw and Stat-O-Seal and tighten securely.
- h. Remove load cell from containment vessel and wipe clean. Reclaim the hydraulic fluid (if it is clean) or dispose of all waste materials according to governmental or your company's proscribed environmental protection regulations.
- i. Disconnect the hand pump from the torque gauge.
- j. Replace the brass cap on the torque gauge check valve fitting.

## 6.C.3 Reference Checking Your Torque Measurement System

The following steps define a process for determining if your torque measurement system is correctly measuring and indicating within an expected range. This procedure is best suited for performing in a shop or location removed from the drill floor, within range of a crane. This is a reference check and not a calibration. Calibrations must be performed at an authorized calibration facility.

Tension Load Cell

- a. Locate a known weight in the range of approximately 500 to 1000 lbs (227 to 455 kg), and move the weight next to the tong and backup assembly.
- b. Remove the tension load cell from the tong, but do not disconnect from the torque gauge.
- c. Suspend the load cell, piston side up, from a crane capable of supporting the known weight in Step 3a.
- d. Connect the rod side of the load cell to the known weight, and use the crane to hoist the weight from the surface to be suspended freely.

Continued on next page...

**6.C.3 Reference Checking Your Torque Measurement System (Continued):**Tension Load Cell (continued):

- e. Perform a simple calculation to determine the expected indication on the torque gauge based on the known hoisted weight. This is a calculation that must be performed using imperial units (eg., pounds and feet). The calculation is: [KNOWN WEIGHT] x [ARM LENGTH (in feet)]. For example, if the arm length is 36 inches and the hoisted weight is 1000 lbs the calculation is:

$$1000 \times (36/12) = 3000$$

Therefore, the expected indication on the torque gauge should be 3000 lbs-ft.

**6.C.4 Repair And Calibration**

Return the load cell and indicator gauge to the authorized repair facility for repairs and calibration.



**This page intentionally  
left blank**





## SECTION 7: OEM DOCUMENTATION

THE MANUFACTURER INFORMATION CONTAINED IN THIS SECTION HAS BEEN OBTAINED FROM PUBLICLY AVAILABLE WEB SITES AND HAS BEEN PROVIDED FOR INFORMATION PURPOSES ONLY. MCCOY GLOBAL DOES NOT GUARANTEE THE ACCURACY OF THE INFORMATION CONTAINED IN THIS SECTION. ALL ORIGINAL COPYRIGHTS CLAIMED BY THE MANUFACTURER(S) APPLY.



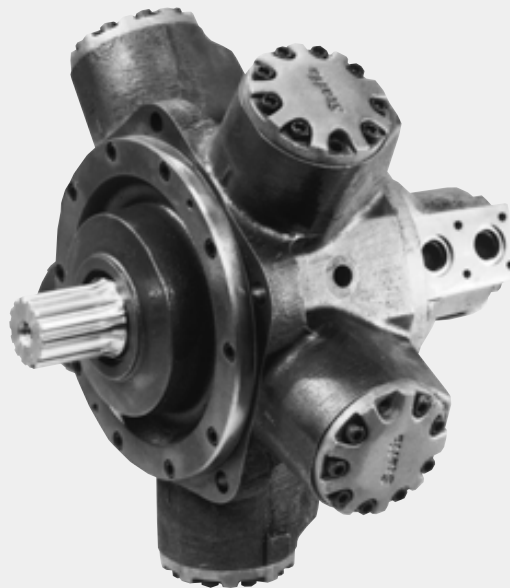
**This page intentionally  
left blank**



Kawasaki Motors Corp., U.S.A.  
Precision Machinery Division

# HMB 080

## Staffa Fixed Displacement Hydraulic Motor



**CONTENTS**

	<i>Page</i>
1. General Description.....	2
2. Functional Symbols .....	2
3. Model Code .....	3
4. Performance Data:	
Motor data .....	4
Rating definitions .....	4
Output torques .....	4
Bearing life .....	5
Volumetric efficiency .....	6
5. Circuit and Application Notes:	
Starting torques .....	6
Low speed operation .....	6
High back pressure .....	6
Boost pressure .....	6
Cooling flow .....	6
Motor casing pressure .....	7
6. Hydraulic Fluids .....	7
7. Temperature Limits .....	7
8. Filtration .....	7
9. Noise Levels .....	7
10. Polar Moment of Inertia .....	7
11. Mass .....	7
12. Installation Data:	
General .....	7
Crankcase drain .....	7
Start-up .....	7
13. Installation Dimensions .....	8 to 11

**1. GENERAL DESCRIPTION**

The HMB080 fixed displacement motor is one of 12 frame sizes in the Kawasaki “Staffa” range of high torque, low speed radial piston motors which extends from 94 to 6800 cm<sup>3</sup>/r (5.76 to 415 in<sup>3</sup>/r) capacity. The rugged, well-proven design incorporates hydrostatic balancing techniques to achieve high efficiency, combined with good breakout torque and smooth running capability.

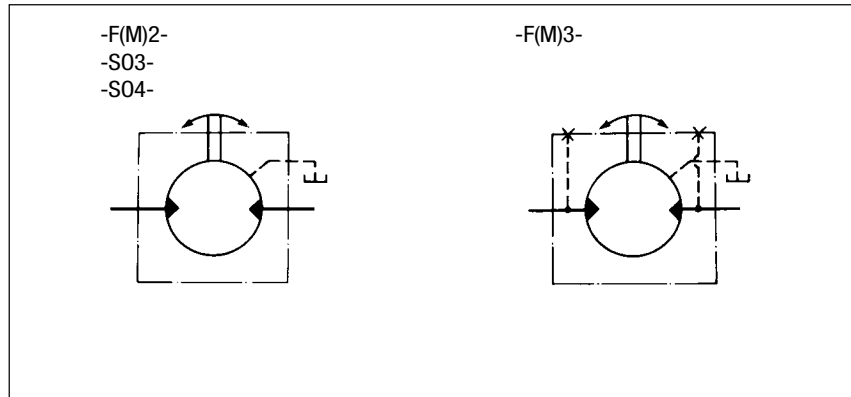
Various features and options are available including, on request, mountings to match competitor interfaces.

The HMB080 is capable of torque outputs up to 5950 Nm (4390 lbf ft) and speeds to 300 r/min with a continuous output of up to 100 kW (134 hp).

The Kawasaki “Staffa” range also includes dual and continuously variable displacement motors, plus matching brakes and gearboxes to extend the available torque range.

**2. FUNCTIONAL SYMBOLS**

All model types with variants in model code position **4**



### 3. MODEL CODE

Features shown in brackets ( ) may be left blank according to requirements.  
All other features must be specified.

**(F\*\*)-HM(\*)B080-(H)\*(V)-\*\*-{\*\*}-3\*-(PL\*\*)**

1

2

3

4

5

6

7

#### 1 FLUID TYPE

Blank = Petroleum oil  
F3 = Phosphate ester (HFD fluid)  
F11 = Water-based fluids (HFA, HFB and HFC)

#### 2 MODEL TYPE

Blank = Standard ("HMB")  
M = To NCB (UK) specification 463/1981 ("HMMB")  
R = Dual mount (front or rear)

#### 3 SHAFT TYPE

Use "H" prefix code as noted to specify "hollow" shafts with through hole  $\varnothing$  26,2 (1.03 dia).

*Hollow shafts are available only with type "S04" main port connection.*

(H)P\* = Cylindrical shaft with key

(H)S\* = Cylindrical, 14 splines to BS 3550

(H)Z\* = Cylindrical shaft to DIN 5480 (W70 x 3 x 22 x 7h)

(H)Q\* = Female, 24 splines to BS 3550

T\* = Long tapered, keyed shaft

X\* = Short tapered, keyed shaft

\* For installations where shaft is vertically upwards specify "V" after shaft type letter to ensure that additional high level drain port is provided.

#### 4 MAIN PORT CONNECTIONS

Models with 2 $\frac{1}{4}$ " distributor valve  $\blacktriangle$

F2 $\blacklozenge$  = SAE 1", 4-bolt (UNC) flanges

FM2 $\blacklozenge$  = SAE 1", 4-bolt (metric) flanges

Models with 3" distributor valve

S03 = 6-bolt (UNF) flange (Staffa original valve housing)

F3 = SAE 1 $\frac{1}{4}$ ", 4-bolt (UNC) flanges

FM3 = SAE 1 $\frac{1}{4}$ ", 4-bolt (metric) flanges

Models with 4" distributor valve  $\blacksquare$

Must be specified when requiring hollow shafts, type HP, HS, HZ or HQ

S04 $\blacksquare$  = 6 bolt (UNF) flange (Staffa original valve housing)

$\blacktriangle$  Gives minimum overall length of HMB080 motor

$\blacklozenge$  Max. inlet flow 200 l/min (53 USgpm); reduced max. continuous speed and output power, see "Performance Data", page 4.

$\blacksquare$  Obligatory for hollow shafts. See increased installation dimensions with 4" valve.

#### 5 TACHO/ENCODER DRIVE

T = Staffa original tacho drive

T1 = Suitable for Hohner 3000 series encoders. (Encoder to be ordered separately)

Omit if not required and when specifying shaft types "H\*\*"

#### 6 DESIGN NUMBER, 3\* SERIES

Subject to change. Installation and performance details remain unaltered for design numbers 30 to 39 inclusive.

#### 7 SPECIAL FEATURES

PL\*\* = non-catalogued features, e.g.:

Stainless steel shaft sleeves

Alternative encoder and tacho drives

Alternative port connections

Shaft variants

Alternative reduced capacities

Special mountings

Special paint

\*\* Number assigned as required to specific customer build.

**4. PERFORMANCE DATA**

Performance data is valid for Staffa HMB080 motors fully run in and operating with petroleum oil. See separate table for pressure and speed limits when using fire-resistant fluids. Leakage values are at fluid viscosity of 50 cSt (232 SUS).

**MOTOR DATA**

		Port connection type, see model code <b>4</b>	
		S03, F3, FM3, S04	F2, FM2
Geometric displacement▲	cm <sup>3</sup> /r (in <sup>3</sup> /r)	1344 (82)	1344 (82)
Average actual running torque	Nm/bar (lbf ft/psi)	19,9 (1.01)	19,9 (1.01)
Max. continuous♦speed	r/min	300	150
Max. continuous♦output	kW (hp)	100 (134)	77 (103)
Max. continuous♦pressure	bar (psi)	250 (3625)	250 (3625)
Max. intermittent♦pressure	bar (psi)	293 (4250)	293 (4250)

▲ Other lower displacements are made available to special order  
 ♦ See "Rating Definitions", this page

**LIMITS FOR FIRE RESISTANT FLUIDS**

Fluid type	Pressure, bar (psi)		Max. speed r/min
	Continuous	Intermittent	
HFA, 5/95% oil-in-water emulsion	103 (1500)	138 (2000)	50% of limits for petroleum oil
HFB, 60/40% water-in-oil emulsion	138 (2000)	172 (2500)	As for petroleum oil
HFC, water glycol	103 (1500)	138 (2000)	50% of limits for petroleum oil
HFD, phosphate ester	250 (3625)	293 (4250)	As for petroleum oil

**RATING DEFINITIONS**

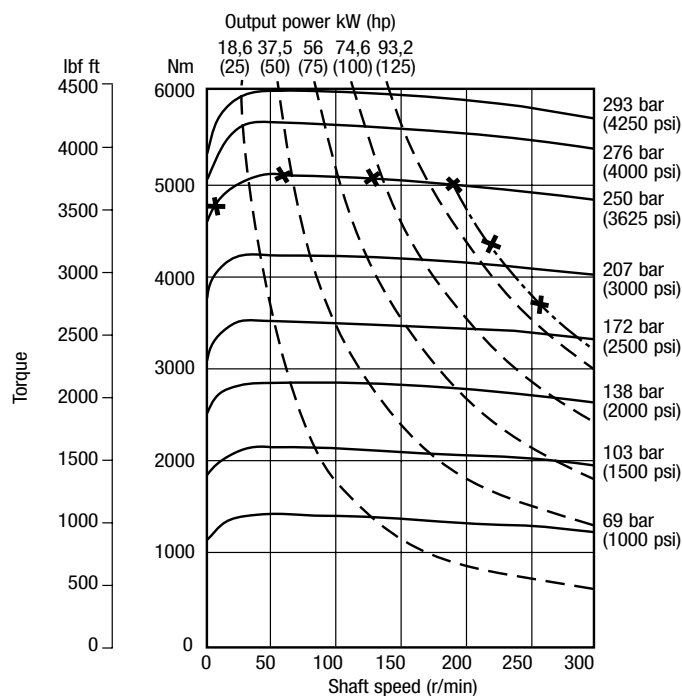
● **CONTINUOUS RATING**  
 For continuous duty the motor must be operating within each of the maximum values for speed, pressure and power.

● **INTERMITTENT RATING**  
 Operation within the intermittent power rating (up to the maximum continuous speed) is permitted on a 15% duty basis, for periods up to 5 minutes maximum.

● **INTERMITTENT MAX. PRESSURE**  
 Up to 293 bar (4250 psi) is allowable on the following basis:  
 (a) Up to 50 r/min: 15% duty for periods up to 5 minutes maximum.  
 (b) Over 50 r/min: 2% duty for periods up to 30 seconds maximum.

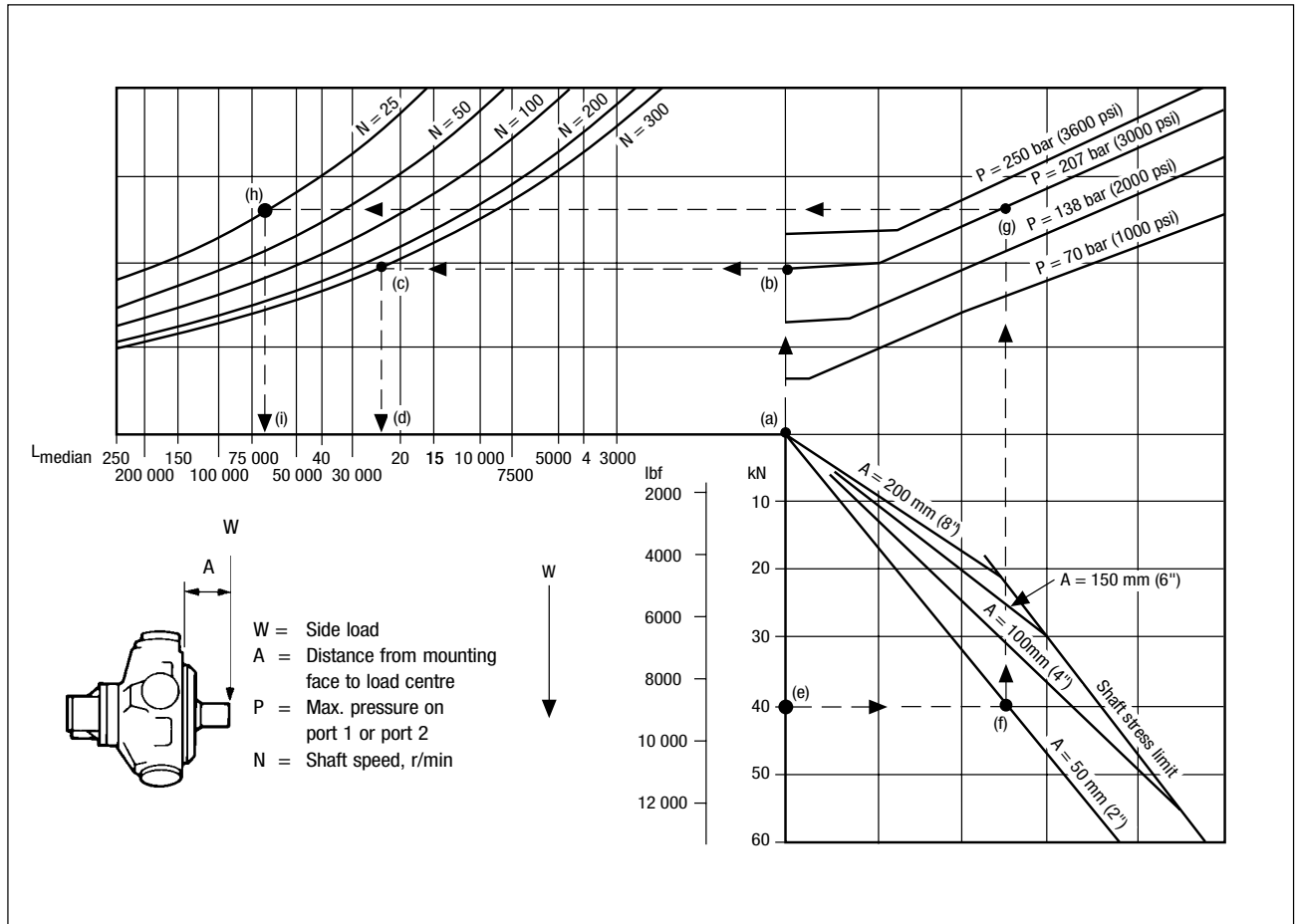
**OUTPUT TORQUES**

The torque curves indicate the maximum output torque and power of a fully run-in motor for a range of pressures and speeds when operating with zero outlet pressure on petroleum oil of 50 cSt (232 SUS) viscosity. High return line pressures will reduce torque for a given pressure differential.



-x-x-x- Upper limit of continuous rating envelope, see "Rating definitions" above.

BEARING LIFE



The nomograph allows the median bearing life to be determined for conditions of:

1. No side load and no axial thrust
2. Side load and no axial thrust

▲ To determine L10 life predictions per ISO 281-1-1977 multiply the median figure by 0.2.

For more precise life prediction, or where axial thrusts are incurred, a computer analysis can be provided by Kawasaki on receipt of machine duty cycle.

● SHAFT STRESS LIMIT

The shaft stress limit in the nomograph is based on the fatigue rating of shaft types "(H)S" and "(H)P". Infrequent loading above these limits may be permitted; consult Kawasaki.

**HMB080**

Example 1 (follow chain dotted line):

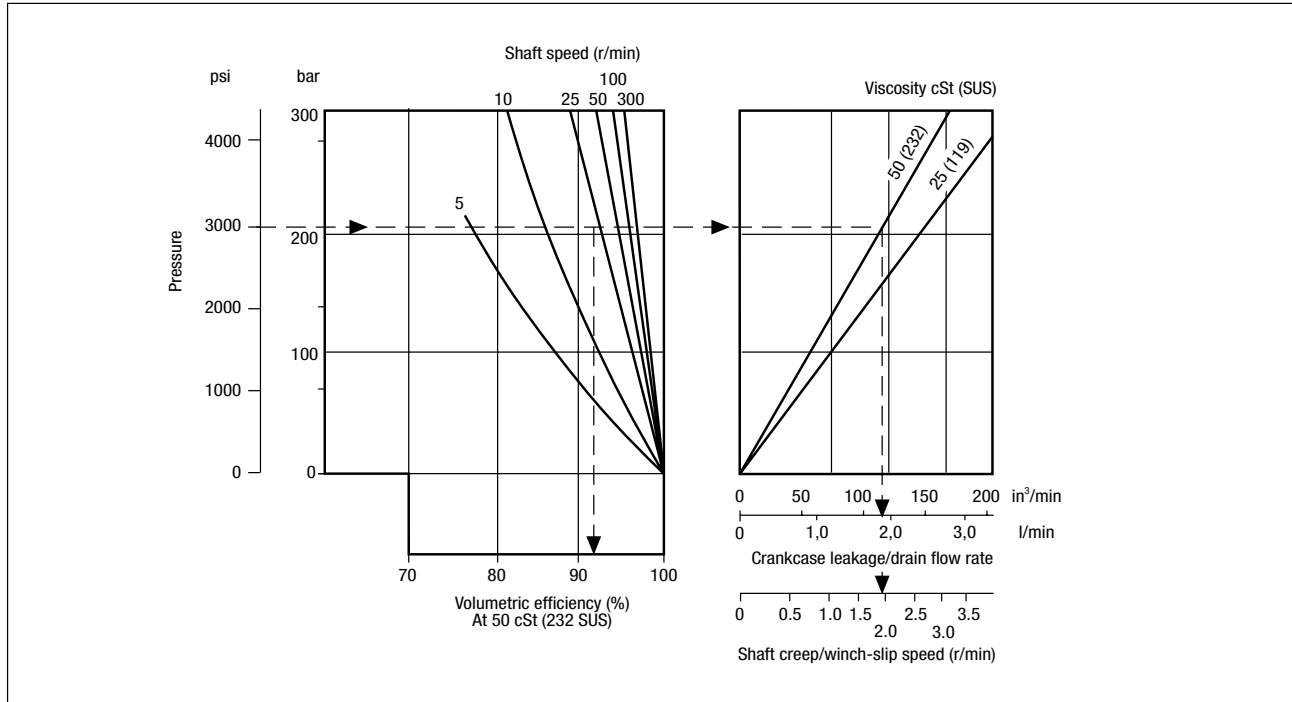
Side load (W)	a) 0
System pressure (P)	b) 207 bar (3000 psi)
Speed (N)	c) 300 r/min
Median bearing life	d) 23 000 hrs
L10 bearing rating = median x 0.2	4600 hrs

Example 2 (follow chain dotted line):

Side load (W)	e) 40 kN (9000 lbf)
Load offset (A) from motor mounting face	f) 50 mm (2.0 in)
System pressure (P)	g) 207 bar (3000 psi)
Speed (N)	h) 25 r/min
Median bearing life	i) 62 000 hrs
L10 bearing rating = median x 0.2	12 400 hrs



VOLUMETRIC EFFICIENCY



This nomograph enables the average volumetric efficiency, crankcase (drain) leakage and “winch slip”/shaft creep speed to be estimated.

Example (follow chain dotted line):

Given:

1. Pressure .....207 bar (3000 psi)
2. Speed .....25 r/min
3. Viscosity .....50 cSt (232 SUS)

To obtain:

4. Volumetric efficiency .....91.8%
5. Crankcase leakage .....1.9 l/min (115.0 in<sup>3</sup>/min)
6. Shaft creep speed .....1.9 r/min

The shaft creep speed occurs when the load attempts to rotate the motor against closed ports as may occur, for example, in winch applications.

**5. CIRCUIT AND APPLICATION NOTES**

**STARTING TORQUES**

The starting torques shown on the graph on page 4 are average and will vary with system parameters.

**LOW SPEED OPERATION**

Minimum operating speeds are determined by load conditions (load

inertia, drive elasticity, etc.). For operation at speeds below 3 r/min consult Kawasaki.

**HIGH BACK PRESSURE**

When both inlet and outlet ports are pressurized continuously, the lower pressure in one port must not exceed 70 bar (1000 psi). Consult Kawasaki on applications beyond this limit. Note that high back pressures reduce the effective torque output of the motor.

**BOOST PRESSURE**

When operating as a motor the outlet pressure should equal or exceed the crankcase pressure. If pumping occurs (i.e. overrunning loads) then a positive pressure, “P”, is required at the motor inlet ports. Calculate “P” according to port connection type being used, from:

$$P \text{ (bar)} = 1 + \frac{N^2}{D_{\text{bar}}} + C \text{ bar}$$

$$P \text{ (psi)} = 14.5 + \frac{N^2}{D_{\text{psi}}} + C \text{ psi}$$

Where:

- N = speed, r/min
- C = crankcase pressure
- D = see table

Port connection type	D value
F2 & FM2	D <sub>bar</sub> = 1500 D <sub>psi</sub> = 103
S03, S04 F3, FM3	D <sub>bar</sub> = 10 000 D <sub>psi</sub> = 690

The flow rate of oil needed for the make-up system can be estimated from the crankcase leakage figure (see Volumetric Efficiency graph above). Allowance should be made for other system losses and also for “fair wear and tear” during the life of the motor, pump and other system components.

**COOLING FLOW**

Operation within the continuous ratings does not require any additional cooling.

For operating conditions above “continuous”, up to the “intermittent” ratings, additional cooling oil may be required. This can be introduced through the spare crankcase drain hole or, in special cases, through the valve spool end cap. Consult Kawasaki about such applications.

**MOTOR CASING PRESSURE**

With the standard shaft seal fitted, the motor casing pressure should not exceed 3,5 bar (50 psi). On installations with long drain lines a relief valve is recommended to prevent over-pressurizing the seal.

*Notes:*

1. The casing pressure at all times must not exceed either the motor inlet or outlet pressure.
2. High pressure shaft seals are available to special order for casing pressures of:  
Continuous: 10 bar (150 psi)  
Intermittent: 15 bar (225 psi)
3. Check installation dimensions (page 8) for maximum crankcase drain fitting depth.

**6. HYDRAULIC FLUIDS**

Dependent on motor (see Model Code position **1**) suitable fluids include:

- Antiwear hydraulic oils
- Phosphate esters (HFD fluids)
- Water glycols (HFC fluids) ▲
- 60/40% water-in-oil emulsions (HFB fluids) ▲
- 5/95% oil-in-water emulsions (HFA fluids) ▲

▲ Reduced pressure and speed limits, see page 4.

Viscosity limits when using any fluid except oil-in-water (5/95%) emulsions are:

Max. off load .....	2000 cSt (9270 SUS)
Max. on load .....	150 cSt (695 SUS)
Optimum .....	50 cSt (232 SUS)
Minimum .....	25 cSt (119 SUS)

**PETROLEUM OIL RECOMMENDATIONS**

The fluid should be a good hydraulic grade, non-detergent petroleum oil. It should contain anti-oxidant, anti-foam and demulsifying additives. It must contain antiwear or EP additives. Automatic transmission fluids and motor oils are not recommended.

**7. TEMPERATURE LIMITS**

Ambient min. ....	-30°C (-22°F)
Ambient max. ....	+70°C (158°F)

Max. operating temperature range

	Petroleum oil	Water-containing
Min.	-20°C (-4°F)	+10°C (50°F)
Max.*	+80°C (175°F)	+54°C (130°F)

\* To obtain optimum service life from both fluid and hydraulic system components 65°C (150°F) normally is the maximum temperature except for water-containing fluids.

**8. FILTRATION**

Full flow filtration (open circuit), or full boost flow filtration (closed circuit) to ensure system cleanliness of ISO 4406/1986 code 18/14 or cleaner.

**9. NOISE LEVELS**

The airborne noise level is less than 66,7 dB(A) DIN (70 dB(A) NFPA) throughout the “continuous” operating envelope.

Where noise is a critical factor, installation resonances can be reduced by isolating the motor by elastomeric means from the structure and the return line installation. Potential return line resonances originating from liquid borne noise can be further attenuated by providing a return line back pressure of 2 to 5 bar (30 to 70 psi).

**10. POLAR MOMENT OF INERTIA**

Typical data: 0,06 kg m<sup>2</sup> (210 lb in<sup>2</sup>).

**11. MASS**

Approx., all models: 144 kg (317 lb).

**11. INSTALLATION DATA**

**GENERAL**

● Spigot

The motor should be located by the mounting spigot on a flat, robust surface using correctly sized bolts. The diametral clearance between the motor spigot and the mounting must not exceed 0,15 mm (0.006 in). If the application incurs shock loading, frequent reversing or high speed running, then high tensile bolts should be used, including one fitted bolt.

● Bolt torque

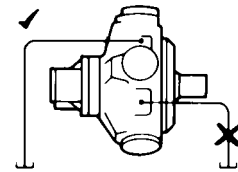
The recommended torque wrench settings for the mounting bolts are:  
M20 bolts.....407±14 Nm (300±10 lbf ft)  
3/4” bolts.....393±14 Nm (290±10 lbf ft)

● Shaft coupling

Where the motor is solidly coupled to a shaft having independent bearings the shafts must be aligned to within 0,13 mm (0.005 in) TIR.

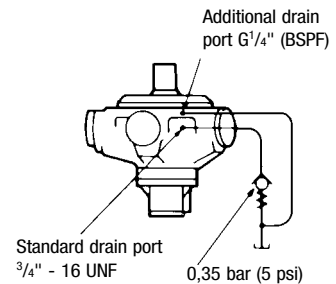
**CRANKCASE DRAIN**

Motor axis horizontal



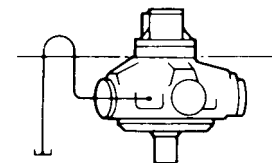
The crankcase drain must be taken from a position above the horizontal centre line of the motor.

Axis vertical, shaft up



An additional G1/4” (BSPF) drain port is provided when the “V” (shaft vertically upwards) designator is given after the shaft type letter in position **3** of the model code. This additional drain should be connected into the main motor casing drain line downstream of a 0,35 bar (5 psi) check valve to ensure lubrication of the upper bearing, see above diagram.

Axis vertical, shaft down



Use any drain position. The drain line should be run above the level of the uppermost bearing; if there is risk of siphoning then a siphon breaker should be fitted.

**START-UP**

Fill the crankcase with system fluid. Where practical, a short period (30 minutes) of “running-in” should be carried out.

13. INSTALLATION DIMENSIONS IN MM (INCHES)

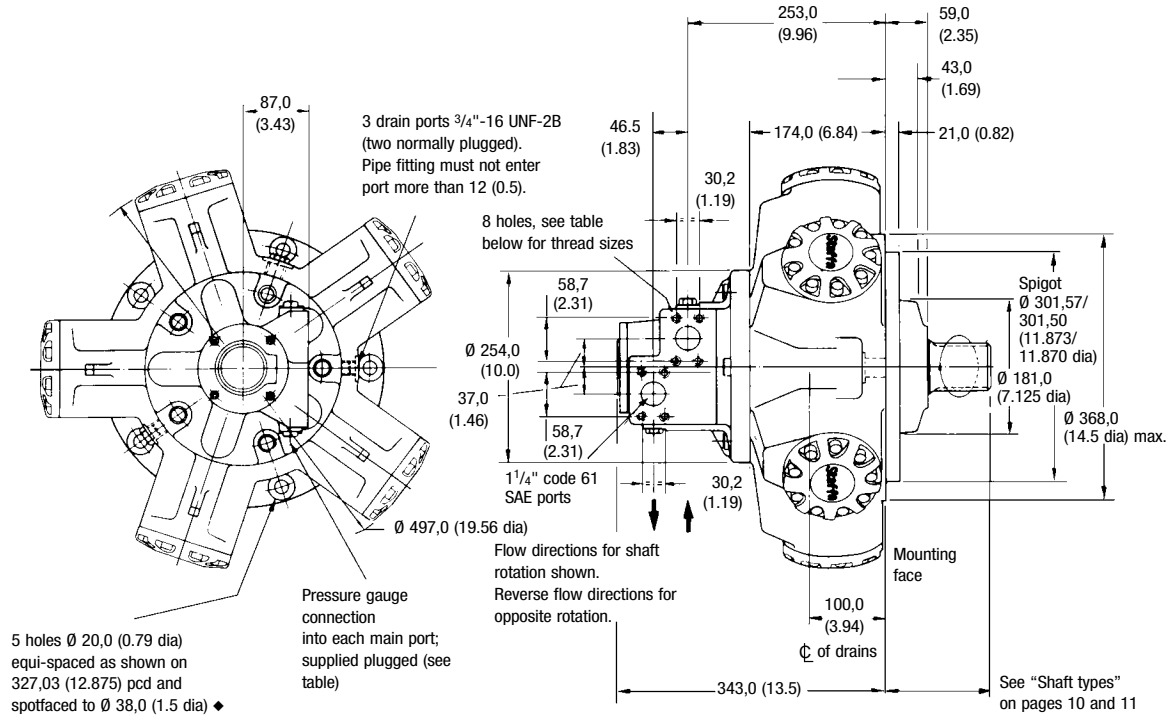
**FRONT-MOUNTING MODELS**

**HMB080 MOTORS WITH TYPE "F3"/"FM3" (1 1/4" SAE) PORT CONNECTION**

See separate drawing for dual-mount model.

See additional views for shaft types and for types "S03" and "S04" port connection.

See drawing of dual-mount model for details of types "F2" and "FM2" port connection.



Port flange bolt tappings

Model code	Tapping size	Gauge connections
F3	7/16"-14 UNC-2B x 27,0 (1.06) full thread depth	9/16"-18 UNF-2B, SAE J475
FM3	M12 x P1.75 x 27,0 (1.06) full thread depth	G1/4" (BSPF)

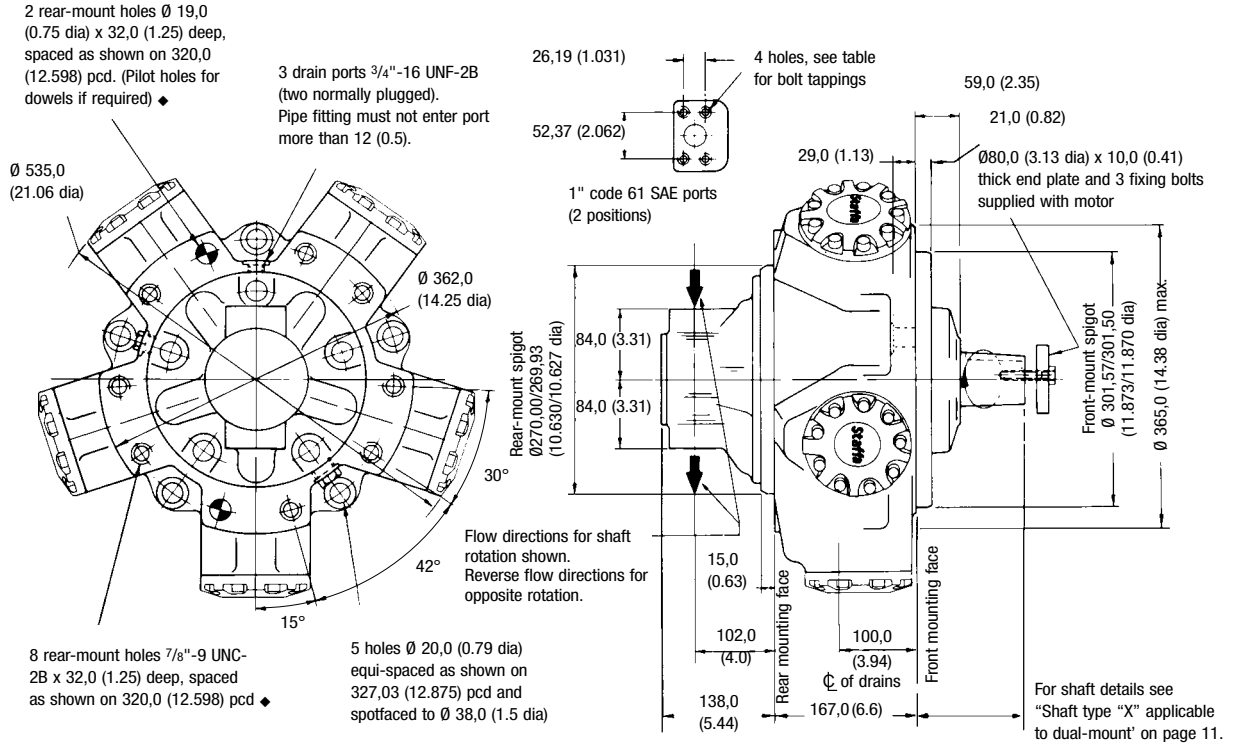
◆  $\varnothing$  0,15 (0.006)

**DUAL-MOUNT MODELS**

**HMRB080 MOTORS WITH TYPE "F2"/"FM2" (1" SAE) PORT CONNECTION**

See additional views for shaft types and for types "S03" and "S04" port connection.

See drawing of front-mount model for details of types "F3" and "FM3" port connection.

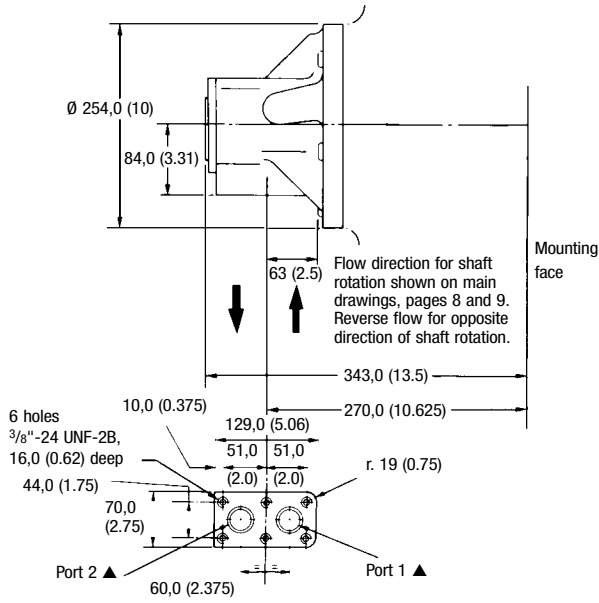


Port flange bolt tappings

Model code	Tapping size
F2	$\frac{3}{8}$ "-16 UNC-2B x 22,0 (0.87) deep
FM2	M10 x P1.5 x 22,0 (0.87) deep

$\varnothing$  0,15 (0.006)

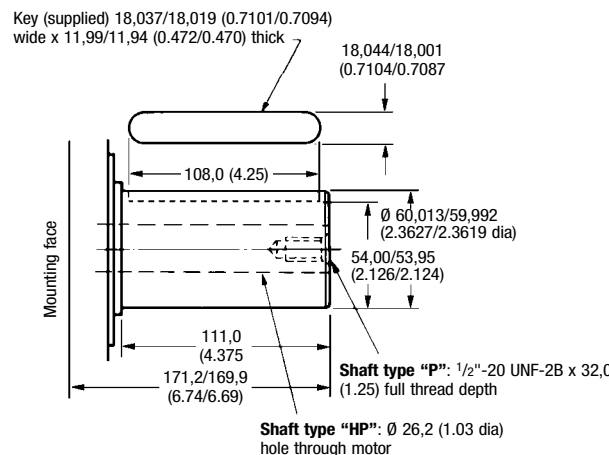
**3" VALVE HOUSING WITH 6-BOLT FLANGE, "SO3" IN MODEL CODE POSITION 4**



Flow direction for shaft rotation shown on main drawings, pages 8 and 9. Reverse flow for opposite direction of shaft rotation.

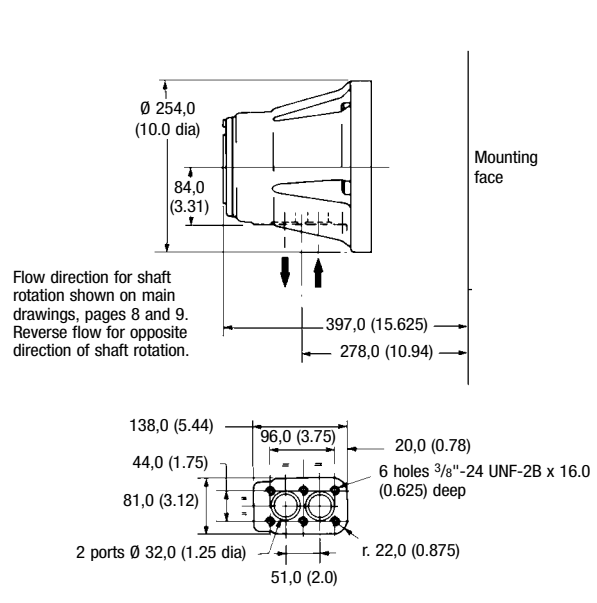
▲  $\varnothing 28$  (1.125 dia) with recess for 31,0 (1.22) i/d x  $\varnothing 4$  (0.157 dia) section O-ring

**SHAFT TYPES "P" AND "HP", MODEL CODE POSITION 3**  
Cylindrical shaft with key



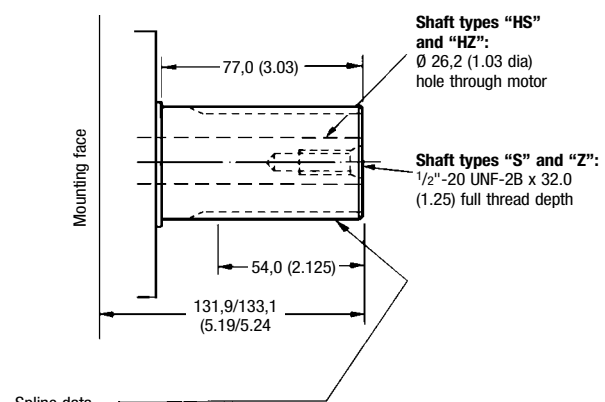
Shaft type "P":  $\frac{1}{2}$ "-20 UNF-2B x 32,0 (1.25) full thread depth  
Shaft type "HP":  $\varnothing 26,2$  (1.03 dia) hole through motor

**4" VALVE HOUSING WITH 6-BOLT FLANGE, "SO4" IN MODEL CODE POSITION 4**



Flow direction for shaft rotation shown on main drawings, pages 8 and 9. Reverse flow for opposite direction of shaft rotation.

**SHAFT TYPES "S" AND "HS", MODEL CODE POSITION 3**  
Cylindrical shaft with 14 splines to BS 3550-1963  
**SHAFT TYPES "Z" AND "HZ", MODEL CODE POSITION 3**  
Cylindrical shaft with splines to DIN 5480



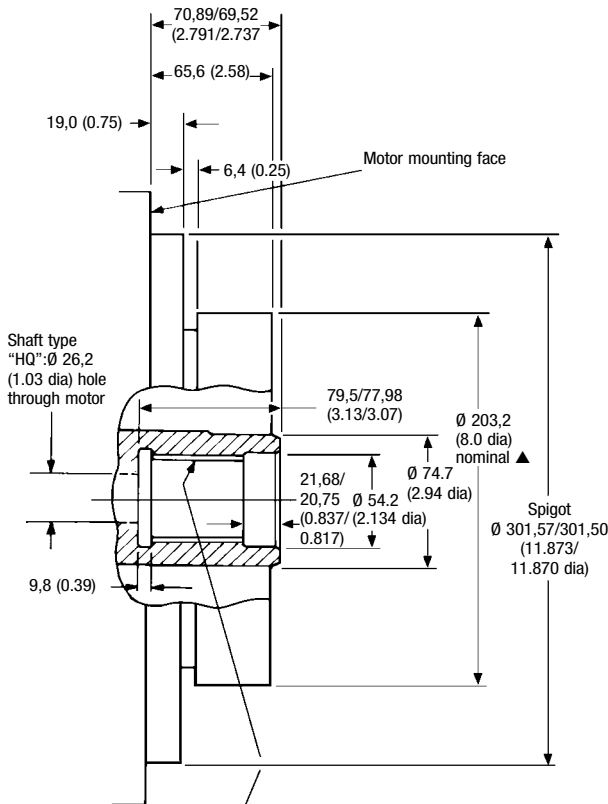
Spline data

For shaft types "S" and "HS" to BS 3550/SAE J498c (ANSI B92.1 1970 class 5)	
Flat root side fit, class 1	
Pressure angle	30°
Number of teeth	14
Pitch	6/12
Major diameter	62,553/62,425 (2.4627/2.4577)
Form diameter	55,052 (2.1674)
Minor diameter	54,084/53,525 (2.1293/2.1073)
Pin diameter	8,128 (0.3200)
Diameter over pins	71,593/71,544 (2.8186/2.8167)
For shaft types "Z" and "HZ"	
DIN 5480, W70 x 3 x 22 x 7h	

**SHAFT TYPES “Q” AND “HQ”, MODEL CODE POSITION 3**

Female shaft with 24 splines to BS 3550

Note: The “Q” and “HQ” shafts will transmit the maximum torque given on page 4. However, customers should ensure that their own mating shaft will transmit the torque required in their application.



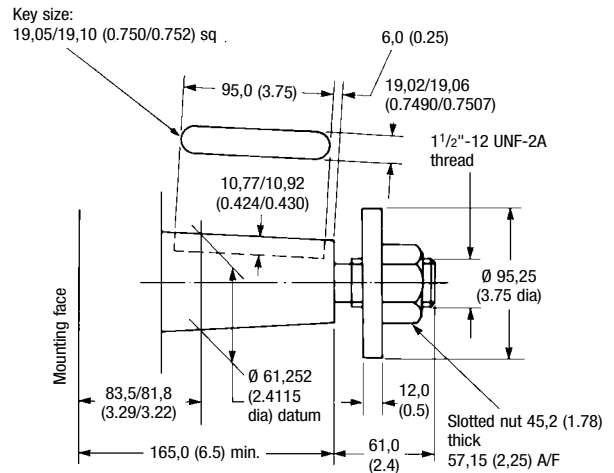
**Spline data**

To BS 3550	
Flat root side fit, modified	
Pressure angle	30°
Number of teeth	24
Pitch	12/24
Major diameter	53,246/52,916 (2.0963/2.0833)
Minor diameter	48,811/48,684 (1.9217/1.9167)
Pin diameter	3,658 (0.1440)
Pin flattened to	3,560 (0.1400)
Diameter between pins	45,626/45,550 (1.7963/1.7933)

▲ Use mounting face spigot for motor location

**SHAFT TYPE “T”, MODEL CODE POSITION 3**

Long taper, with key



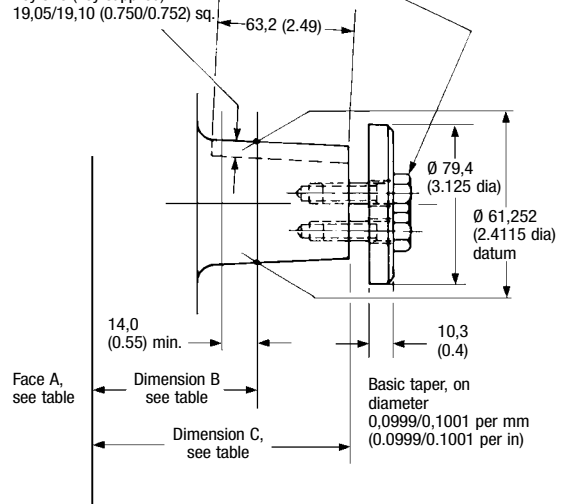
Basic taper, on diameter  
0,0999/0,1001 per mm  
(0.0999/0.1001 per in)

**SHAFT TYPE “X”, MODEL CODE POSITION 3**

Short taper, with key

Keyway size:  
19,02/19,05 (0.749/0.750) wide x  
10,77/10,92 (0.424/0.430) deep  
Key size (key supplied):  
19,05/19,10 (0.750/0.752) sq.

Clamp plate and 3 bolts supplied  
Bolts M12 x P1.75 x 30,0 (1.18) long; hex.  
19,0 (0.75) A/F  
(3 holes in shaft end equi-spaced on 30,0  
(1.18) pcd, tapped to 23,0 (0.9) min.  
full thread depth)



For front-mount models:

Face A	=	Front mounting face
Dim. B	=	83,31/81,43 (3.280/3.206)
Dim. C	=	129,4 (5.09)

For dual-mount models:

Face A	=	Rear mounting face
Dim. B	=	250,8/248,92 (9.874/9.800)
Dim. C	=	297,0 (11.69)



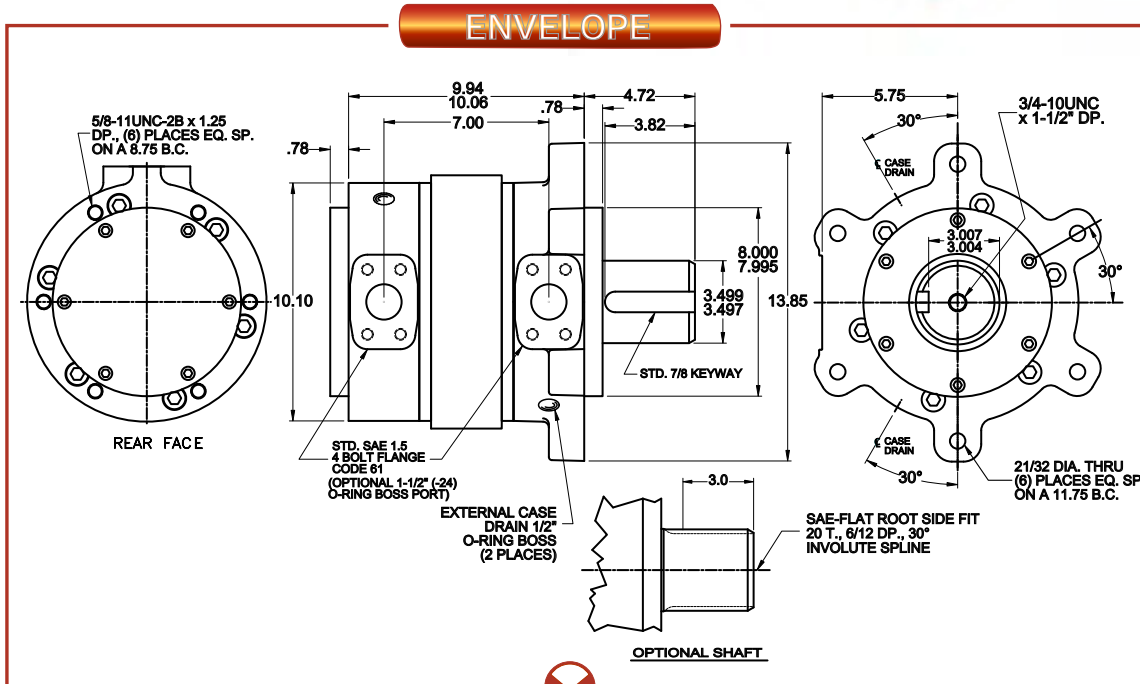
125 Series

**POWER to be the Best!**

**MOTOR SELECTION GUIDE**

**Features of the 125 Series Standard Motor:  
Standard Motor - 3000 PSI (Code 61)**

- A variety of fixed displacement motors ranging from 60 in<sup>3</sup> to 250 in<sup>3</sup>.
- 4-Port double motors providing 2-Speed operation with external valving.
- Starting and stall torques equal to 90-94% of theoretical torque.
- Speed to 350 RPM continuous.
- Up to 300 HP continuous.
- Compact envelope sizes.
- Weighs 225 lbs. to 280 lbs.



Made in USA

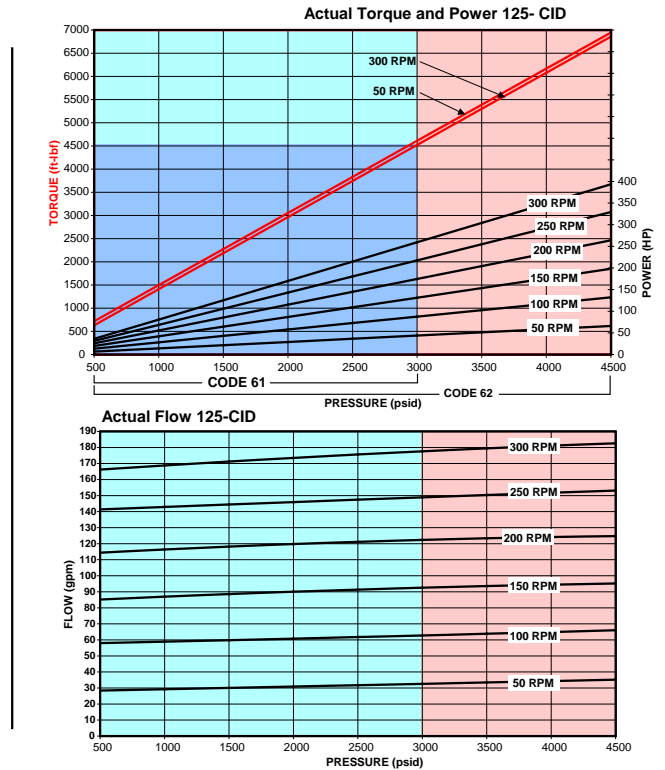
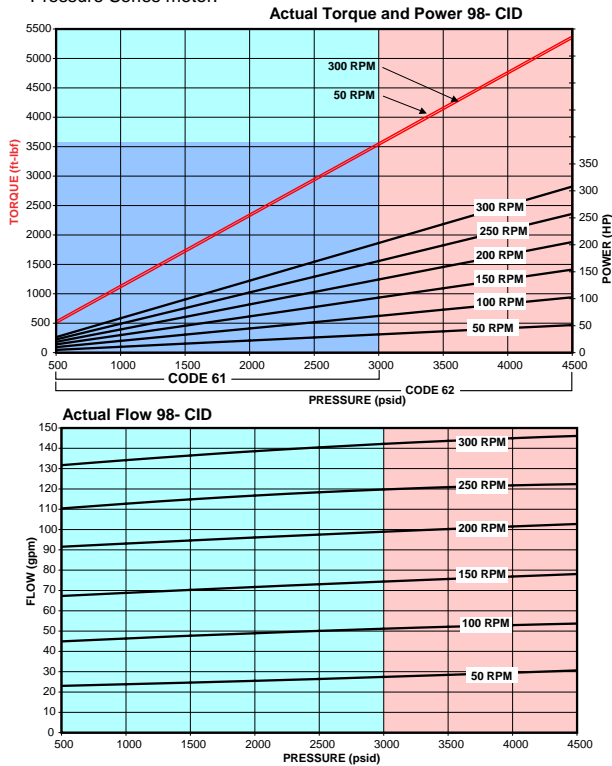
PUBLICATION DS1251005 3/04



## Performance Data

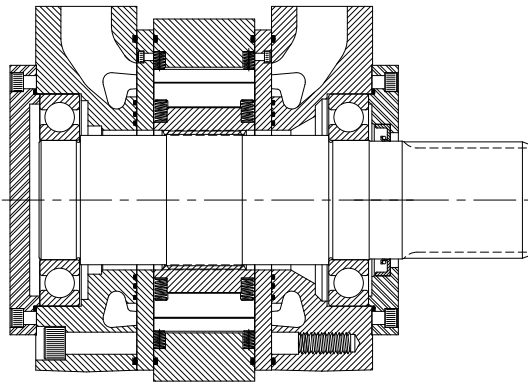
Charts shown are for 98 and 125 CID. See website at [www.rineer.com](http://www.rineer.com) for additional charts. Performance data obtained at 140°F with ISO 46 (DTE 25). Code 61 and 62 data shown. Code 62 extended data applies only to Code 62 High Pressure Series motor.

**VANE CROSSING VANE** - With its vane crossing vane design, the Rineer motor produces much higher volumetric and mechanical efficiencies than is possible with a standard vane type design. This design provides a sealing vane between stator cavities to improve mechanical and volumetric efficiencies.



Performance of the Rineer 125 Series Motor has been greatly enhanced by internal design changes resulting in a pressure balanced rotating group. Benefits of this new design include reduced cross port leakage and increased efficiency as well as greater reliability at higher pressures. This patented design has been in effect for over 5 years.

### Bearing Data - Standard Motor

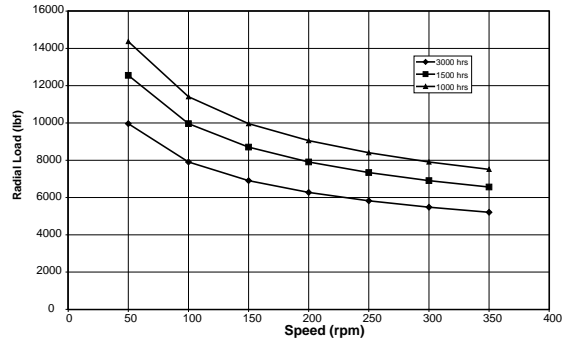


**BEARING LOADING** - The bearings in the 125 Series can accept radial load per the radial capacity charts to the right. Thrust loading is not recommended for the standard motor. For thrust-type applications, see the thrust capable motor bearing chart on the opposite page.

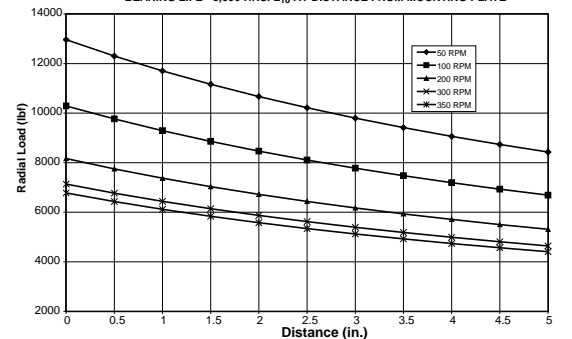
**HORSEPOWER LIMITATION** - Maximum horsepower limitation may vary with different applications. When using the 125 Series standard motor above 300HP, consult a Rineer Application Engineer.

**SINGLE STACKED, DOUBLE STACKED** - Single stacked motors have displacements ranging from 60 in<sup>3</sup> to 125 in<sup>3</sup> and are comprised of a single rotor stator package located between two housings. Double stacked motors have displacements ranging from 150 in<sup>3</sup> to 250 in<sup>3</sup> and are comprised of two rotor stator packages located between two housings. Any of the single stacked rotor stator packages may be placed together to form a double stacked motor.

B1: 218, 218 BEARING LIFE FOR RADIAL LOAD AT 2.8" FROM MOUNTING FACE TO CENTER OF OUTPUT SHAFT



B1: 218, 218 BEARING LIFE - 3,000 HRS. L<sub>10</sub> AT DISTANCE FROM MOUNTING PLATE



**Envelope - Double Key**

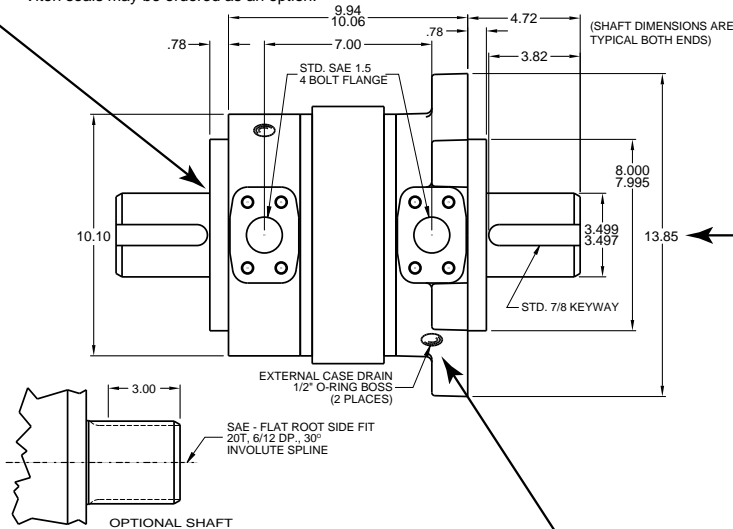
**STARTING AND STALL TORQUE**

The Rineer motor produces torque curves which are virtually flat, with starting and stall torque equal to approximately 90-94% of theoretical torque.

**MORE POWER STROKES PER REVOLUTION**

The 125 Series has six stator cavities and 16 rotor vanes. Each rotor vane works in each stator cavity once per revolution, which results in 96 power strokes per revolution. This helps produce higher mechanical efficiency and flatter torque curves.

**SEALS** - Buna N seals are supplied standard. Viton seals may be ordered as an option.

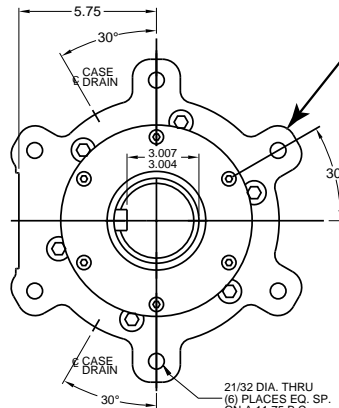


**CASE DRAIN AND CROSS PORT LEAKAGE**

The combined case drain and cross port leakage of the 125 Series single stacked motor is approximately 1 to 1-1/2 GPM per 1,000 PSI, while the double stack motor is approximately 2 GPM per 1,000 PSI. This will vary with the oil viscosity and internal clearance selection.

**HOUSING OPTIONS**

The standard 125 Series motors have one six-bolt front housing and one rear housing. Special 125 Series motors are available with two six-bolt front housings or two rear housings. The rear housing is provided with six each 5/8-11 mounting threads on a 8.750 bolt circle. The mounting position is unrestricted. The shafts, pilots, and mounting faces should be within .002 TIR.



**ROTATION** - The 125 Series motor rotates equally well in either direction and smoothly throughout its entire pressure and speed range. Looking into the end of the shaft, rotation is clockwise when oil is supplied to the port nearest the shaft.

**FLUID** - We suggest premium grade fluids containing high quality rust, oxidation and foam inhibitors, along with anti-wear additives. For best performance, minimum viscosity should be maintained at 100 SSU or higher. Fluid temperature should not exceed 180°F. Elevated fluid temperature will adversely affect seal life while accelerating oxidation and fluid breakdown. Fire resistant fluids may be used with certain limitations. Contact Rineer for additional information.

**FILTRATION** - 25 micron minimum.

**CASE DRAIN** - The 125 Series motor requires an external case drain. Two case drain ports are supplied; use the port at the highest elevation. We recommend case pressure of less than 35 PSI.

**CASE DRAIN CIRCULATION** - Fluid should be circulated through the two case drain ports when a temperature differential exists between the motor and the system in excess of 50°F. **Should this occur, contact a Rineer Application Engineer.**

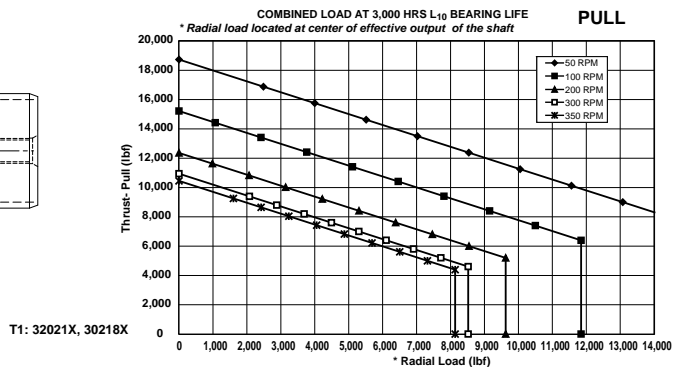
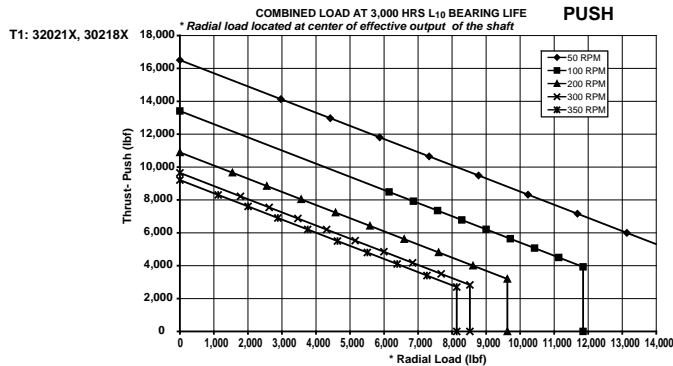
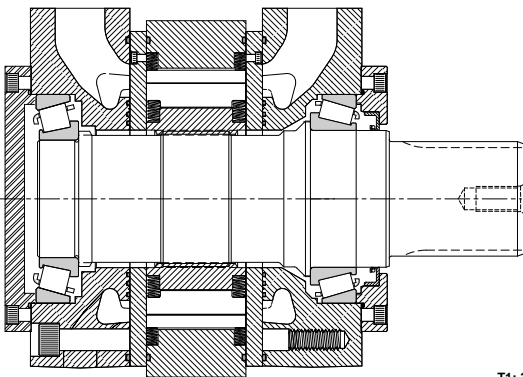
**Bearing Data - Thrust Capable**

**BEARING LOADING THRUST CAPABLE**

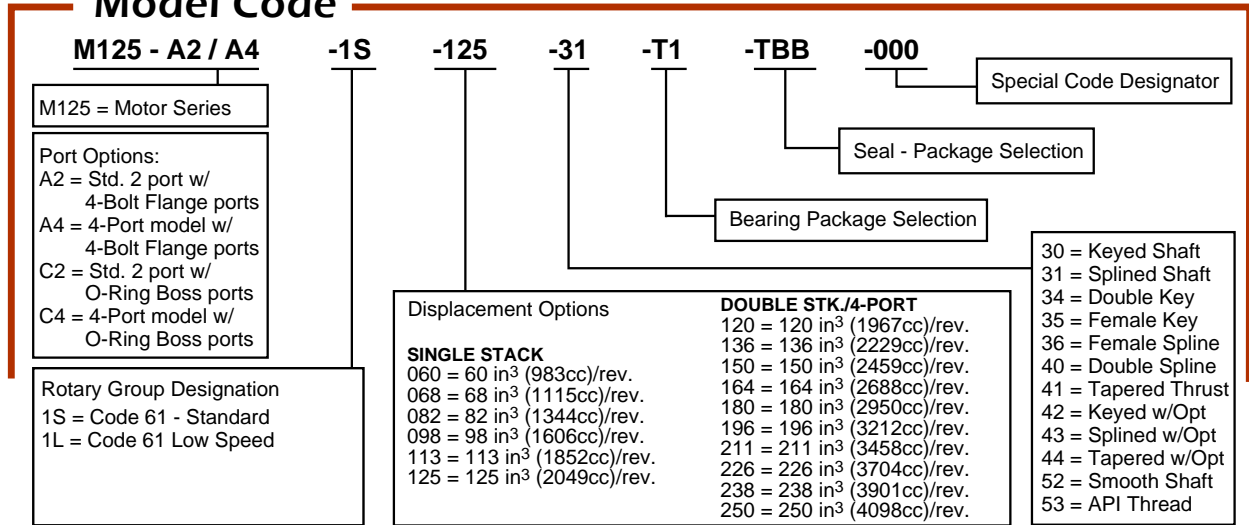
The bearings in the 125 Series Thrust capable motor can accept thrust and radial load per the push/pull capacity charts to the right. Thrust loading is allowed up to the parameters indicated on the charts with shaft configurations including standard keyed and splined as well as a light duty API drill motor. For applications not requiring thrust, see the standard motor bearing charts on the opposite page.

**HORSEPOWER LIMITATION**

Maximum horsepower limitation may vary with different applications. When using the 125 Series standard motor above 300HP, consult a Rineer Application Engineer.



### Model Code



### Applications



**For durable hydraulic motors that meet your demands, specify Rineer.**

For over 35 years, we have specialized in only one thing - engineering the right motor for your needs. Rineer delivers the performance you can count on.

Visit our website at [www.rineer.com](http://www.rineer.com)



#### Limited Warranty Policy

Rineer Hydraulics, Inc. warrants that, at the time of shipment to Purchaser, our product will be free of defects in the material and workmanship. The above warranty is LIMITED to defective products returned by Purchaser to Rineer Hydraulics, Inc., freight prepaid within four hundred and fifty-five (455) days from date of shipment, or one (1) year from date of first use, whichever expires first. We will repair or replace any product or part thereof which is proved to be defective in workmanship or material. There is no other warranty, expressed or implied, and in no event shall Rineer Hydraulics, Inc. be liable for consequential or special damages. Dismantling the product, operation of the product beyond the published capabilities or for purposes other than that for which the product was designed, shall void this warranty.



331 Breesport San Antonio, Texas 78216

210-341-6333 Fax: 210-341-1231 e-mail: [sales@rineer.com](mailto:sales@rineer.com)

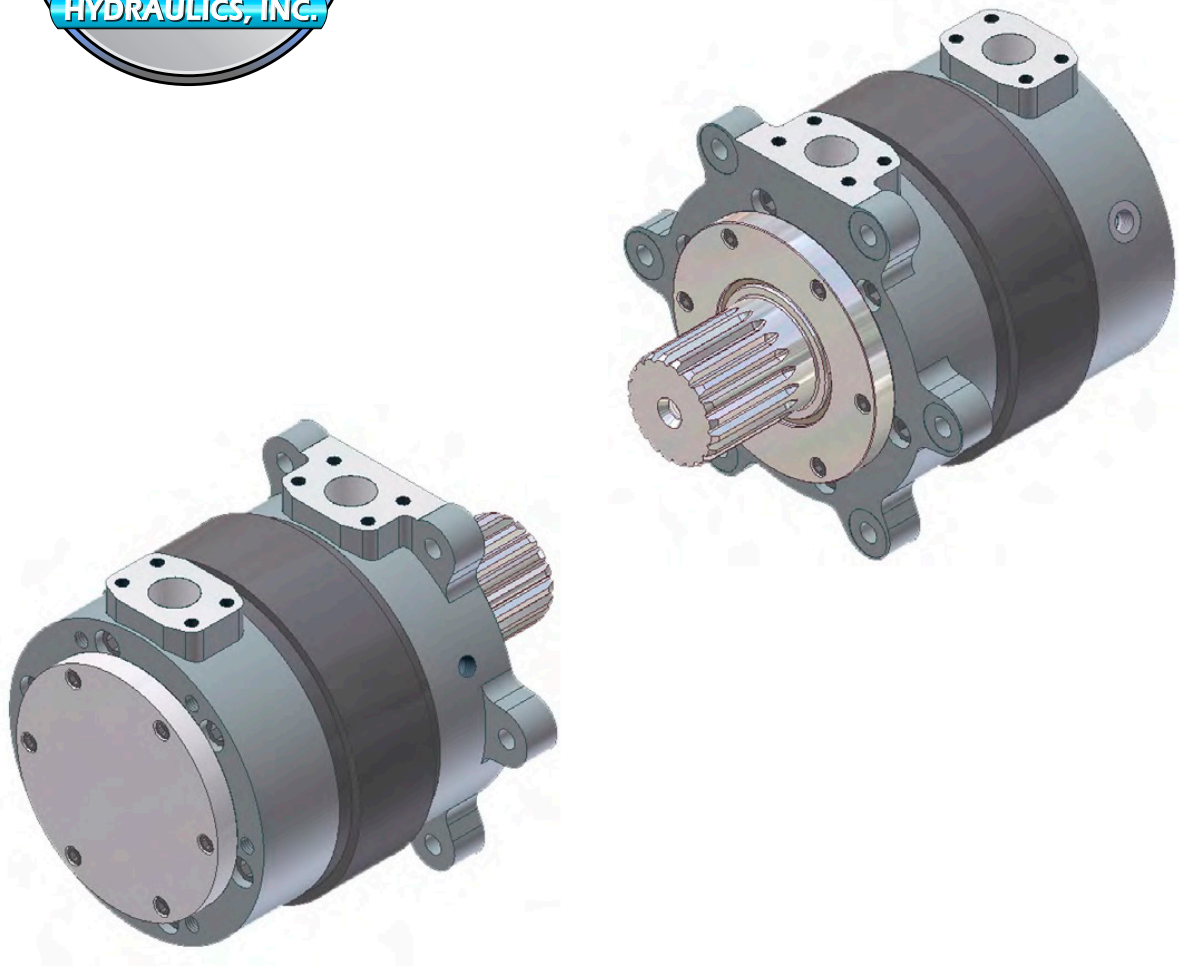


**This page intentionally  
left blank**



# Repair Manual

125 Series



**125**  
Series

Key / Spline

Double Stack Key / Spline

4-Port Key / Spline

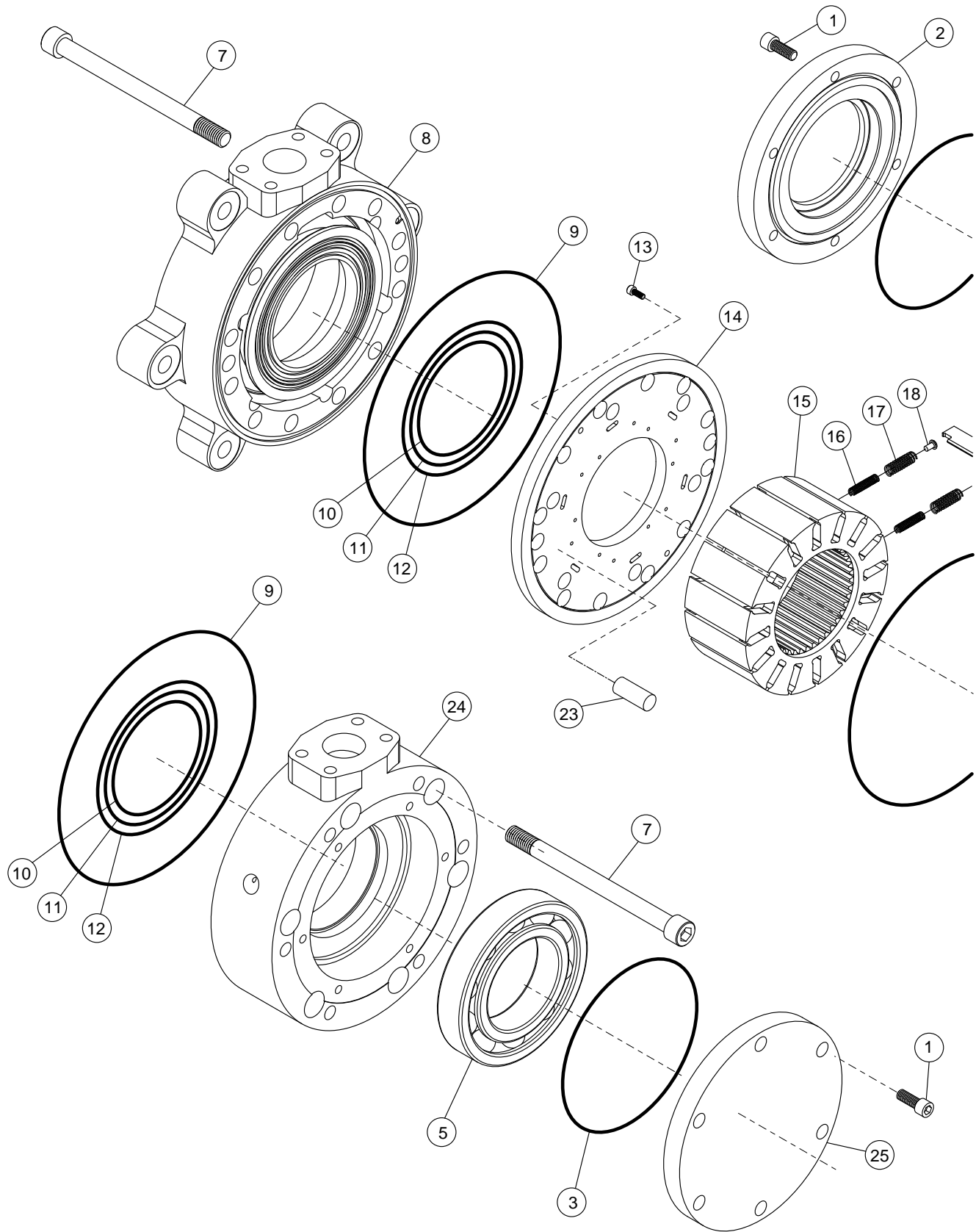
Thru Key / Spline

Drill Motor - API Thread

Made in USA

Data Sheet RM1255030 8/01/02

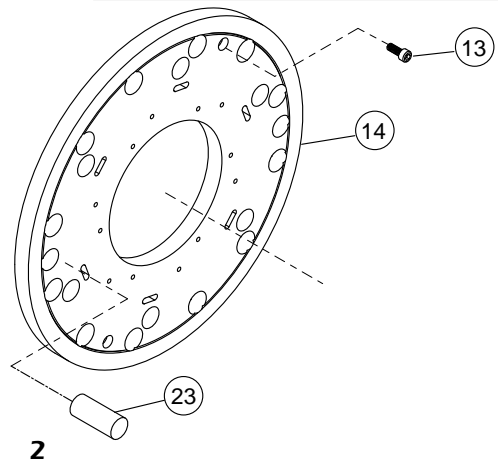
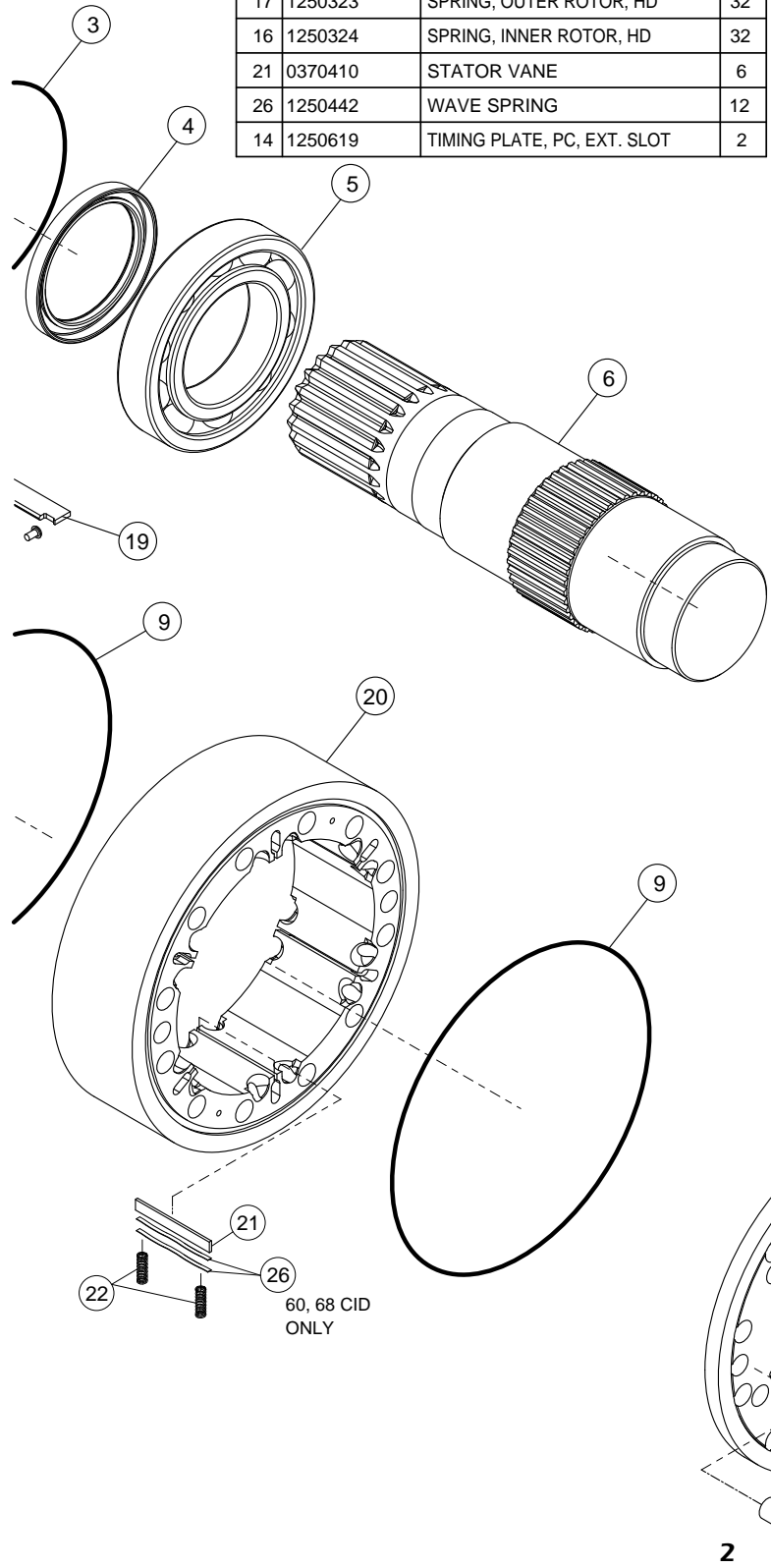




1

PARTS SUBSTITUTED IN 60 & 68 C.I.D. ROTATING GROUPS			
19	1250317PC	ROTOR VANE	16
17	1250323	SPRING, OUTER ROTOR, HD	32
16	1250324	SPRING, INNER ROTOR, HD	32
21	0370410	STATOR VANE	6
26	1250442	WAVE SPRING	12
14	1250619	TIMING PLATE, PC, EXT. SLOT	2

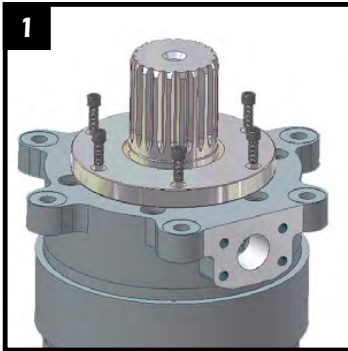
SERIES 125 PC EXPLODED VIEW			
ITEM	PART NO.	DESCRIPTION	QTY
1	1250117	BOLT, SEAL PLATE	12
2	1250162	SEAL PLATE, TCN, 3-1/2	1
3	1250114	O-RING, SEAL PLATE	2
4	1250187	SEAL, TCN, 3-1/2	1
5	1250711	BALL BEARING	2
6	1250702	SHAFT, SPLINED	1
	1250701	SHAFT, KEYED	1
7	0370902	BOLT, 5/8-11 x 8", MAIN	12
8	1251158	FRONT HOUSING, A, PC	1
9	1250610	O-RING, MAIN	4
10	1250877	O-RING, THERMAL, INNER	2
11	1250878	O-RING, THERMAL, MIDDLE	2
12	1250879	O-RING, THERMAL, OUTER	2
13	1250620	PLATE SCREW	4
14	1250618	PLATE, TIMING, PC	2
	1250619	PLATE, TIMING, PC (HI SPD)	2
15	1250315PC	ROTOR, S	1
	1250315PL	ROTOR, L	1
16	1250321	SPRING, INNER ROTOR	32
17	1250320	SPRING, OUTER ROTOR	32
18	1250322	SPRING BUTTON(NOT FOR 60,68)	32
19	1250314PC	VANE, ROTOR, S	16
	1250314PL	VANE, ROTOR, L	16
20	1250406	STATOR, 125 CID	1
	1250401	STATOR, 113 CID	
	1250402	STATOR, 98 CID	
	1250403	STATOR, 82 CID	
	1250404	STATOR, 68 CID	
	1250400	STATOR, 60 CID	
21	1250410	STATOR VANE	6
22	1250420	SPRING, STATOR VANE	12
23	1250440	DOWEL PIN, 5/8 x 2	4
24	1250899	REAR HOUSING, A, PC	1
25	1250817	SEAL PLATE, REAR, BLIND	1



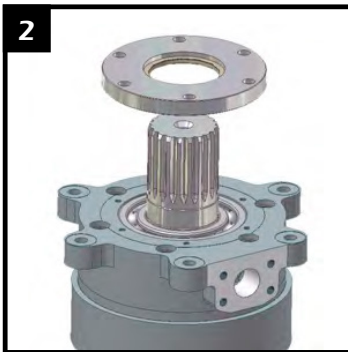


**WARNING:** RINEER RECOMMENDS FOLLOWING ALL STANDARD SHOP SAFETY PRACTICES SPECIFICALLY INCLUDING WEARING OF EYE PROTECTION.

**Removal of Seal Plate (Front and Rear)**



1 Loosen and remove (6) or (12) 3/8-16 seal plate bolts.



2 1) Lift up on the seal plate. Protect the shaft seal from being cut by the keyway (keyed shaft) by placing a thin strip of metallic tape over the shaft. Smooth any burrs that may tear or snag the seal. 2) Remove seal plate o-ring from groove in seal plate.

NOTE:  
The shaft seal on a std. motor is pressed into the seal plate and can be removed in the reverse manner.



3 1) Loosen and remove (6) or (12) 3/8-16 bolts from rear seal plate. If motor has double ended shaft, remove seal plate following same precaution as stated above for front seal. 2) Remove seal plate o-ring from groove in seal plate.

**Removal of Shaft and Bearings**

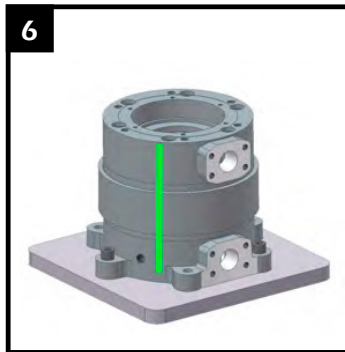


4 Press shaft and front bearing out of motor through front housing, leaving rear bearing in place.

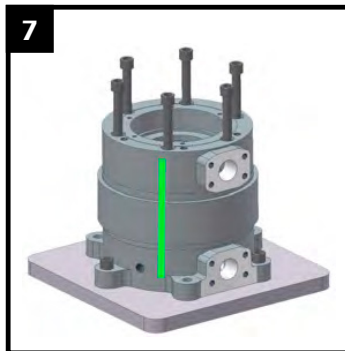


5 Front bearing can be inspected in place on the shaft, or pressed off to be inspected or replaced.

**Disassembly of Motor**



6 The 125 motors should be positioned as shown in a suitable mount to hold the unit during main bolt removal. To ensure proper orientation during reassembly, use a laquer paint pen or some type of oil/solvent proof marker to mark a line down the side of the motor.



7 Loosen and remove the six 5/8-11 main bolts. Any bolt heads showing heavy corrosion or signs of rounding of the hex form should be replaced.



8 Turn the motor over. Attach some type of plate or bar to the rear housing port pad to secure the motor for removal of remaining 5/8-11 main bolts. Take precautions to ensure that no damage is done to the port face in the area where the o-ring seals.

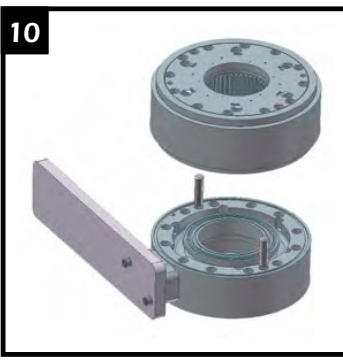
**WARNING:** RINEER RECOMMENDS FOLLOWING ALL STANDARD SHOP SAFETY PRACTICES SPECIFICALLY INCLUDING WEARING OF EYE PROTECTION.



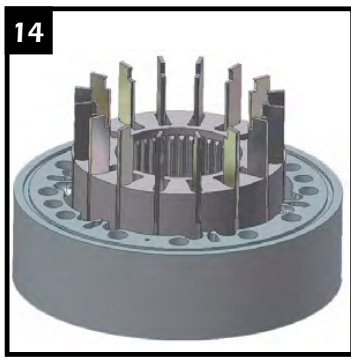
Remove front housing as shown. Remove o-rings from housing and dowel pins from the rotating group.



- 1) Replace plate on rotor/stator cartridge.
- 2) Turn rotor/stator cartridge over.
- 3) Repeat steps 11 & 12.



1) Remove rotating group from rear housing as shown. Place the rotating group on a clean surface for disassembly and inspection.  
 2) Remove dowel pins and o-rings from the housing.  
**NOTE: DOUBLE STACK**  
 When disassembling a double stack, the rotating group next to the rear housing has the center plate attached. Remove this rotating group first, then carefully remove front group.



- 1) Remove the rotor.
- 2) Remove both the rotor and the stator vanes.  
**NOTE:** On motors manufactured prior to 1987, rotor vane slots and rotor vanes should be numbered so that vanes can be reassembled in the same vane slot.
- 3) Separate parts and rinse in solvent tank.

**Disassembly of Rotating Group**

**Inspection of Parts**



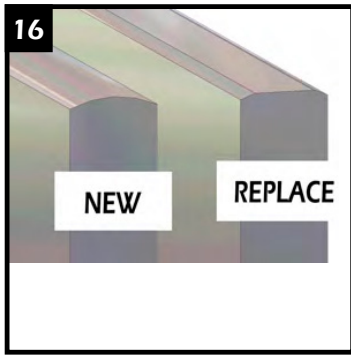
- 1) Place cartridge on any object which will hold it off the table.
- 2) Remove two each 10-32 plate screws.
- 3) Remove timing plate.



Inspect all parts and replace any parts which obviously show excessive wear or damage. We recommend changing all springs and seals whenever the motor has been disassembled.



Using a small screwdriver or pick, remove o-ring and all rotor and stator springs.  
**Note:**  
 Some series rotating groups may contain additional "wave" springs in the stator vane slot (see inset).



**VANES:**  
 Normal wear results in slight flattening of vane tips which does not impair motor performance. Replace vane if radius is reduced by 50%. Clearance between the rotor vane and rotor vane slot varies with the vane selection. The design allows the vane to "lean" slightly in the slot, providing the required mechanical seal.

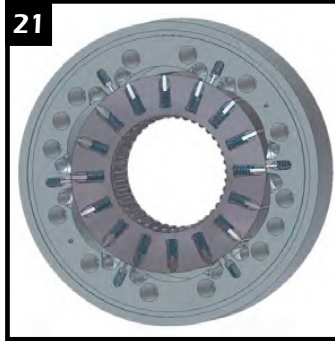
**WARNING:** RINEER RECOMMENDS FOLLOWING ALL STANDARD SHOP SAFETY PRACTICES SPECIFICALLY INCLUDING WEARING OF EYE PROTECTION.

**Assembly of Motor**



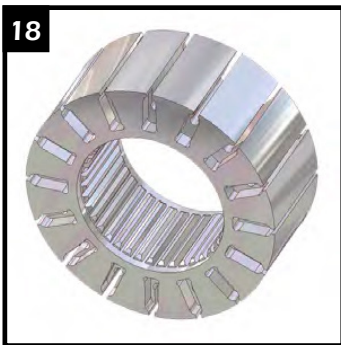
17

**PLATES:**  
Normal wear results in marking or polishing of the timing plate surface, which does not impair motor performance. Replacement of the timing plate is required if any smearing, galling, or heat cracks are present.



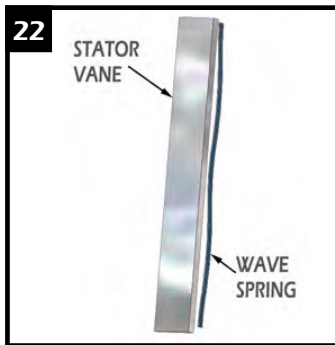
21

1) Reverse the procedures in steps 13, 12, 11, and 10.  
Before installing timing plate onto completed sides of rotating group, pour a small amount of hydraulic oil onto rotor surface.  
2) **NOTE:** Make sure that the radiused edge of each stator vane points to the rotor and the radiused edge of each rotor vane points to the stator.  
3) **NOTE:** Make sure springs are seated in the bottom of the spring pocket in both the rotor and stator.  
**NOTE:** Do not allow the coil of any spring catch on the edge of the rotor or stator vanes.



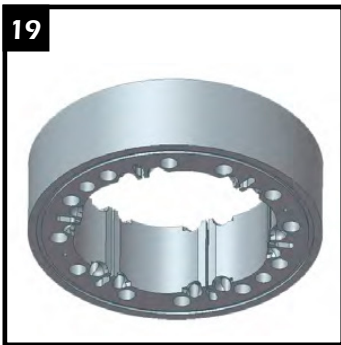
18

**ROTOR:** Normal wear results in polishing of rotor faces which does not impair motor performance. Examine the rotor vane slots closely. Polishing down in the slots is normal, but if there is any indication of a "pocket" forming in the wall of the slot, the rotor should be replaced.



22

Wave springs in the 125 series do not need to be replaced. Certain model codes do not contain wave springs, while other model codes may contain two per vane. Place the stator vane and wave spring in the stator vane slot simultaneously. Note orientation as shown. Do not let the coil spring loop catch between the wave spring and vane.



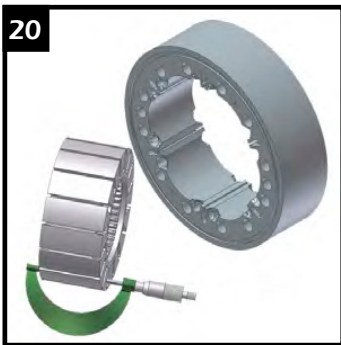
19

**STATOR:** Normal wear results in polishing of cam form which does not impair motor performance. Noticeable wear may be apparent along the corner of one side of the stator vane slot. This does not necessarily require replacement of the stator, but may slightly affect volumetric efficiency.



23

Using a medium India honing stone, lightly dress all machine surfaces to remove any raised metal or burrs. Pay particular attention to the front and rear housing machined faces. Rough handling can cause raised surfaces near the O.D. of the housings which will prevent proper seating of the timing plates to the machined surfaces of the housing. **NOTE:** The pedestal surface (center of the front and rear housing containing two or three o-rings) is .002-.003 below the outer machined surface. Dress these surfaces independently.



20

Measure the rotor and stator length to the fourth decimal point and supply measurement when ordering rotor, stator, or vanes.



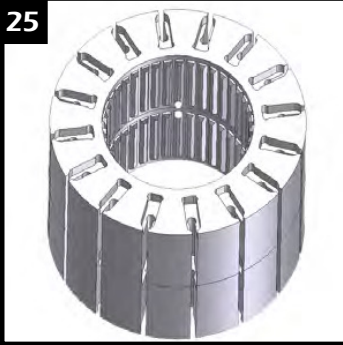
24

Assemble the motor by reversing the previous procedures. Insure that the main body and pedestal o-rings are held in place by using an adequate amount of grease in the o-ring grooves. Line up the housings and rotating group with the paint line made on the motor in step 6.

**WARNING:** RINEER RECOMMENDS FOLLOWING ALL STANDARD SHOP SAFETY PRACTICES SPECIFICALLY INCLUDING WEARING OF EYE PROTECTION.

### Motor Assembly Tips

25



**Note:**

On double stack motors, rotor vane slots must line up.  
1) Place both rotors on the spline of the shaft, rotating one rotor until vane slots line up.  
2) Mark the end of one spline tooth inside each rotor where they meet with white out. This will allow visual realignment after motor is assembled.  
3) When motor is assembled, make sure marks line up before installing shaft. Be careful not to rotate one rotor independently of the other while installing the shaft.

26



Grease the first inch of threads and UNDER the head of the 5/8-11 bolts and insert into motor. Set torque wrench as specified for type of motor to be assembled (see back cover of this manual) and tighten in a star pattern. Install shaft, bearings, and seal plate in reverse order of previous procedures. Rotate shaft to insure no binding is present.



**Information:**

Bolt Torque -  
 Single Stack Main Bolts (5/8-11): 200 ft. lbs.  
 Double Stack Main Bolts (5/8-11): 220 ft. lbs.  
 4-Port Main Bolts (5/8-11): 200 ft. lbs.  
 Seal Plate (3/8-16): 45 ft. lbs.  
 Grease used for bolt threads  
 and o-ring retention:  
 Pennzoil 707L RED  
 Shaft seal assembly lube:  
 Mobilgrease special  
 with Moly

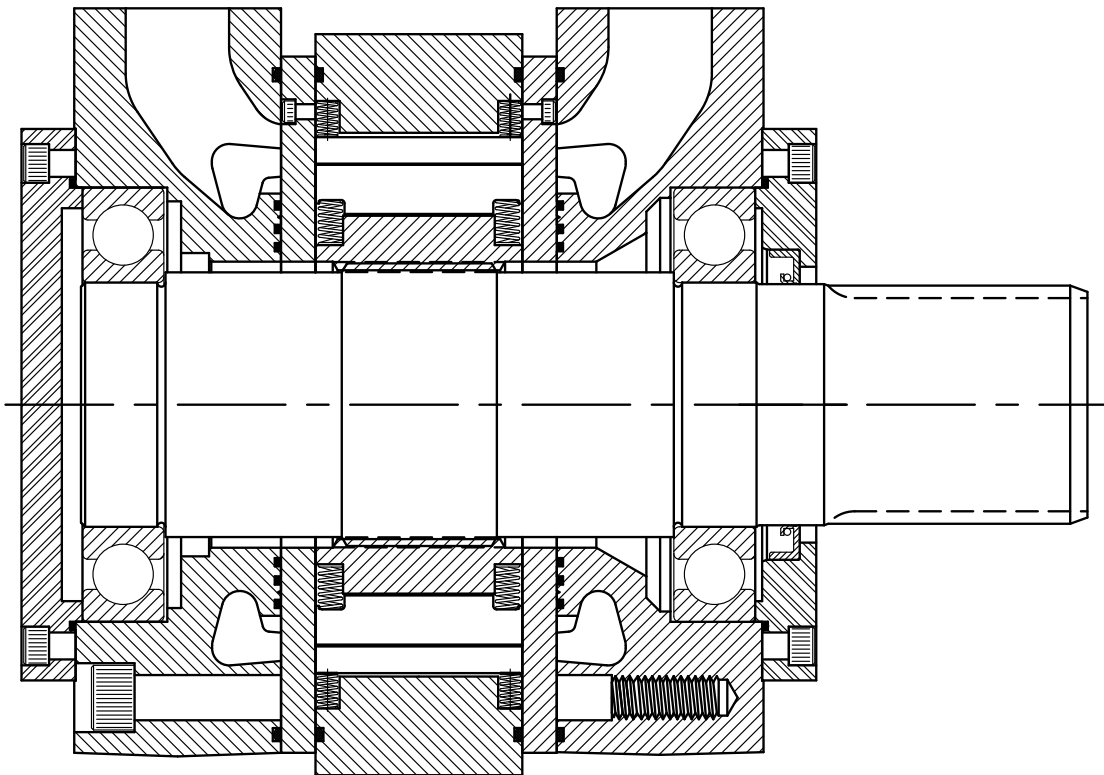
Seal Kits:

Standard 125 series seal kit  
 KT-SE1250948  
 Standard 125 thru-key seal kit  
 KT-SE1250947  
 Standard 125 drill motor seal kit  
 KT-SE1250947  
 Standard 125 double stack seal kit  
 KT-SE1250948DS  
 Standard 125 4-Port seal kit  
 KT-SE1250948FP

Note!

The above seal kits are applicable to the motors shown in this repair manual. Any special motor may have seals & O-rings unique to that motor.

## 125 Series Cross Section

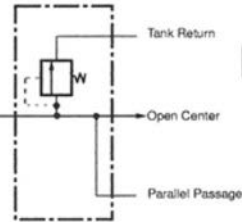


## Inlets (2500 psi)

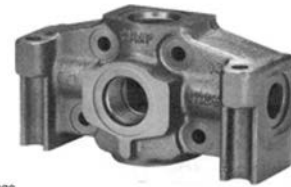
### End Inlet

Code	End Port	Top Port
DVA35-A440	1" NPT	1" NPT
DVA35-A880	SAE-16	SAE-16
DVA35-A980	SAE-20	SAE-16
DVA35-A000	NON-PORTED HOUSING	

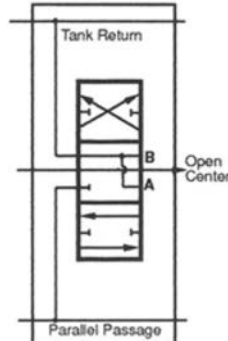
NOTE: Inlets are machined for a main R/V or R/V plug and are furnished with plastic closures. See Section G, Page 32 for inlet port plugs



Schematic shown with main R/V

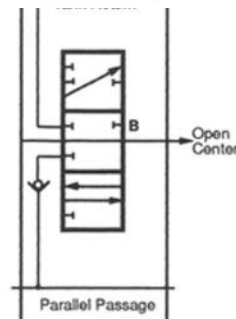


Note: For inlets with solenoid section pilot supply machining, see DVG35 inlet section E1



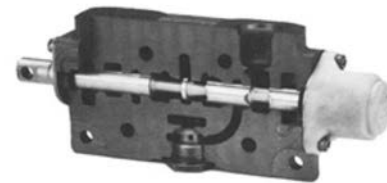
### MA8

Double-Acting Section  
4-Way, 3-Position, Float in Neutral Motor Spool



### SA8

Single-Acting Section  
3-Way, 3-Position, Hold in Neutral Cylinder Spool

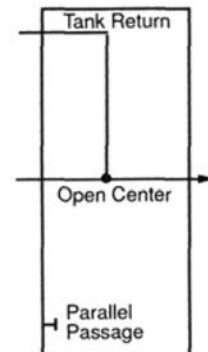


## Outlets

### Tank Return Type

Code	End Port	Top Port
DVA35-TR55	1 1/4" NPT	1 1/4" NPT
DVA35-TR99	SAE-20	SAE-20
DVA35-TR00	NON-PORTED HOUSING	

NOTE: See Section G, Page 32 for Port Plugs



## Adjustable Relief Valve Cartridges

For Inlets and Mid-section Inlets

Code	Description
DVA35-MRV-1	Main R/V pressure range 800-2000 psi. Factory set @ 1500 psi @ 50 gpm
DVA35-MRV-2	Main R/V pressure range 2001-2500 psi. Factory set @ 2500 psi @ 50 gpm.
DVA35-MRVP	Main relief valve plug



# Lo-Boy Work Sections -- Parallel Circuits

Code	4-Way 3-Position Hold In Neutral	3-Way 3-Position Hold In Neutral	4-Way 3-Position Float In Neutral	4-Way 4-Position Float Position Detented	Port Size	Work Port NOT Machined	Spring Return	3-Position Detent	Metered Hydraulic Remote Control	Solenoid Operated	Air Shift		
DVA35-DAO	•					•	•						
DVA35-DA4	•				1" NPT		•						
DVA35-DA8	•				SAE-16		•						
DVA35-SAO		•				•	•						
DVA35-SA4		•			1" NPT		•						
DVA35-SA8		•			SAE-16		•						
DVA35-MA0			•			•	•						
DVA35-MA4			•		1" NPT		•						
DVA35-MA8			•		SAE-16		•						
DVA35-DK8-12V	•				SAE-16					12 VDC			
DVA35-DK8-24V	•				SAE-16					24 VDC			
DVA35-DX4	•				1" NPT				•				
DVA35-DX8	•				SAE-16				•				
DVA35-DV4	•				1" NPT						•		
DVA35-DV8	•				SAE-16						•		
DVA35-MX4			•		1" NPT				•				
DVA35-MX8			•		SAE-16				•				
DVA35-DB4	•				1" NPT			•					
DVA35-DB8	•				SAE-16			•					
DVA35-SB4		•			1" NPT			•					



# Brief Circuit Descriptions

## Series Circuit

Available in DVA20 sections only.

If a machine's work cycle requires simultaneous as well as separate operation of individual hydraulic work functions, a series circuit is right for the job.

As with the other circuits, the oil flows through the open center when all spools are in neutral. There is no parallel passage in standard series sections because they feed directly from the open center passage. If more than one spool is operated, pump flow goes first to the section closest to the inlet. Return flow from the first section is fed back into the open center for use by downstream sections.

Downstream sections can be series, parallel or tandem and will operate in series with the upstream section.

In series circuits, operating pressure is cumulative. Therefore, the sum of the pressures in the circuits can not exceed the circuit or main relief valve setting.

## Parallel Circuits

Parallel circuits are the most common on mobile equipment because more than one function can be operated simultaneously and at random. If two or more functions are fully operated at the same time, the one with the lightest load will assert priority because the fluid will take the path of least resistance. However, the operator can divide the flow between functions by metering the spools.

Movement of the spool meters or shuts off the flow of oil thru the open center passage and pressurizes the parallel passage. Oil is then available, at the operator's discretion, to all work ports connected to the parallel passage.

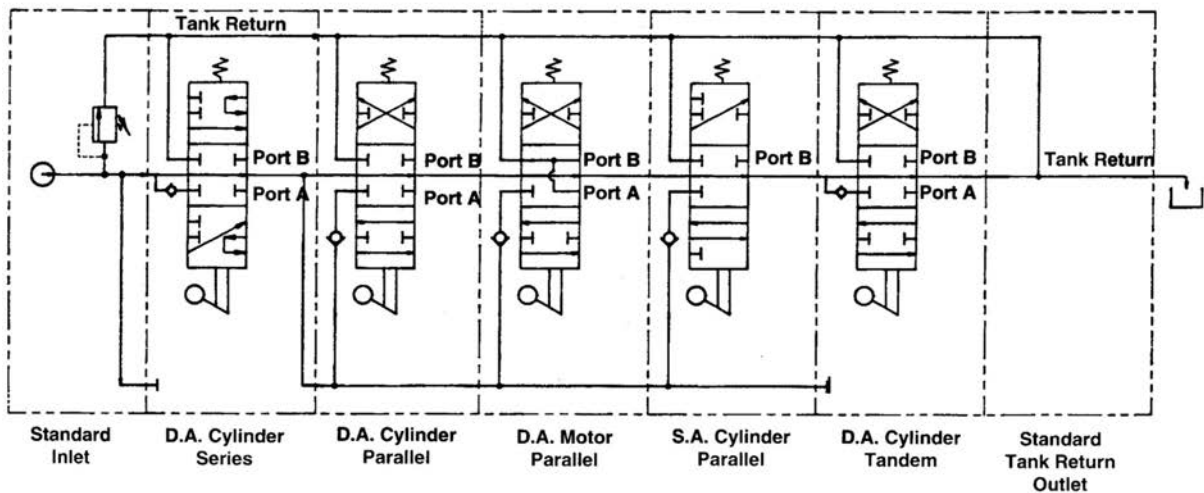
## Tandem Circuits

(Not available in the program)

Tandem circuits are sometimes called priority or standard circuits by other manufacturers. Tandem sections feed from the open center passage like series sections but the return flow is directed to the tank return passage and is not available downstream.

If a tandem section is followed by a series or tandem section, operating the tandem section nearest the inlet will assert priority and downstream sections will not function.

# Typical Work Section Schematics



# VA™/VG™ Valve Service Instructions

## INTRODUCTION

This manual has been prepared to assist you in the proper maintenance of the VA20™/VA35™ and VG20™/VG35™/VG80™ directional control valves. Before any work is done, we suggest that you read the assembly and disassembly instructions completely.

The first rule of good maintenance is cleanliness, which includes a clean environment. **MAKE SURE YOU DISASSEMBLE AND ASSEMBLE YOUR HYDRAULIC EQUIPMENT IN A CLEAN AREA.** Dirt is the natural enemy of any hydraulic system.

## GENERAL INFORMATION

The VA and VG model valves are updated versions of our proven A20™ and A35™ units. The VG models are cast from compacted graphite, a high strength iron alloy, which allows the valve to be rated to 3500 psi. VA models are cast from gray iron and are rated at 2500 psi. These open-center, directional-control valves are available in parallel, tandem, and series circuitry. As needed, the sectional, stack-type construction provides flexibility for the addition or subtraction of work sections to an existing valve bank. This design also permits the combination of parallel, tandem, and series circuitry in a single bank. The internal coring of each valve section determines its circuitry and the number of gasket seals required.

All sections with optional features, such as port relief valves, crossover relief valves, and anti-cavitation checks, are dimensionally larger when measured from the top of the port to the bottom of the housing. These are referred to as “hi-boy” sections. Those without work-port options can use the low-profile castings, which are called “lo-boy” sections.

## REPLACEMENT PARTS

The illustrations and instructions in this manual apply only to the VA/VG series assemblies, subassemblies, and components. All valve components, except for spools and housings, are available as replacement parts or subassemblies. Spools are hone-fitted to their individual housings, so damage to either of these components means the entire section must be replaced.

We recommend that you use only genuine VA/VG series replacement parts in your service program. Manufactured to the same exacting tolerances and quality controls as the original equipment, genuine VA/VG replacement parts may help prevent premature, component failure and costly downtime. Service parts and assemblies are available through your original equipment dealer or any authorized distributor.

## MAINTENANCE

Valves are often used in hazardous environments. Inspect them frequently for damage due to improper use, corrosion or normal wear. If needed, repairs should be made immediately.

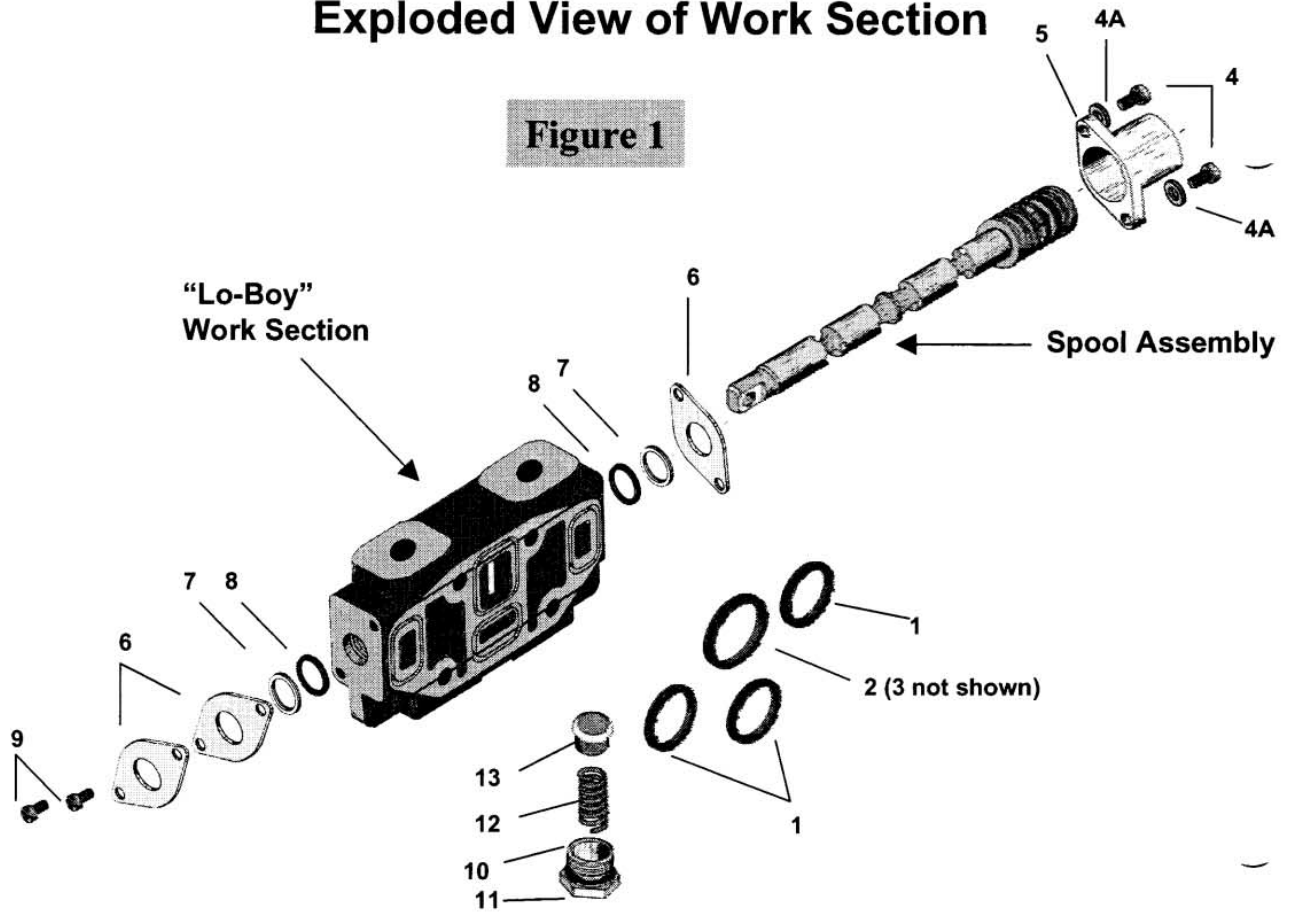
**Always refer to the machine manual for the proper procedure to remove the valve from the machine.**

Remove the valve bank from the equipment, disconnecting all hoses, fittings, control handles and linkage connectors that might be attached to the valve. Plug all ports and thoroughly clean the exterior of the valve bank, then the port plugs can be removed.



### Exploded View of Work Section

Figure 1



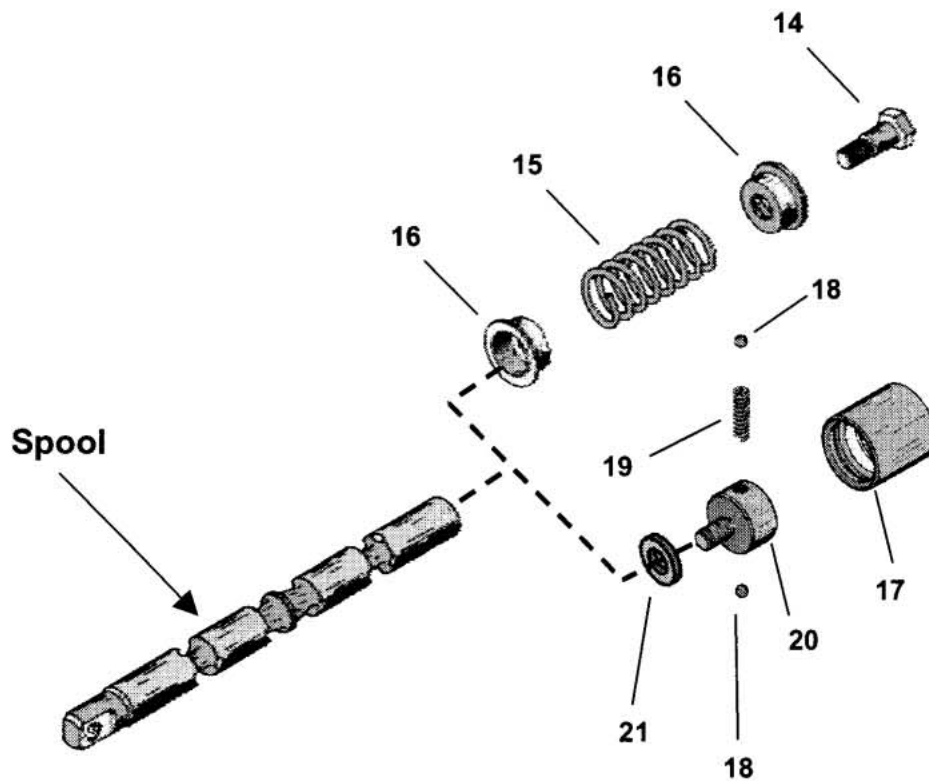
#### Parts List For Work Section

Item	Description	Qty.	VA/VG20 Part No.	VA/VG35 Part No.	VG80 Part No.
<b>Parallel Section Seals* See Figure 1</b>					
1.	Square Seals	3	391-2881-206	391-2881-200	391-2881-433
2.	Square Seal	1	391-2881-200	391-2881-403	391-2881-670
<b>Series Section Seals</b>					
1.	Square Seals	2	391-2881-206	391-2881-200	.....
3.	Square Seal	1	391-2881-627	391-2881-628	.....
<b>Parallel and Series Section Component Parts. See Figure 1</b>					
4.	Back Cap Screws	2	391-1433-020	391-1433-009	(4) 391-1402-068
4A.	Lock washers	8	.....	.....	391-3783-039
5.	Back Cap	1	341-6000-100	342-6000-100	341-0585-099
6.	Retainer Plates	3	391-2183-001	391-2183-005	391-2183-157
7.	Back up Rings	2	391-2681-378	391-2681-426	391-2681-285
8.	Spool Seals	2	391-1985-014	391-2887-212	391-2881-096
9.	Retainer Plate Screws	2	391-1433-015	391-1433-002	(4) 391-1402-015
10.	Check Valve Cap	1	391-0581-044	391-0581-044	391-0585-099
	Or Valve Cap (F.I.N.)	1	391-2281-015	391-2281-015	.....
11.	O Ring Seal **	1	391-2881-204	391-2881-204	391-2881-249
12.	Check Spring **	1	391-3581-713	391-3581-713	391-3581-778
13.	Check Valve Poppet **	1	391-2481-069	391-2481-069	391-2383-091

\*Parallel Sealing Face includes inlets and mid-inlets.

\*\*Not required in Float-in-neutral Sections.

**Figure 2**



**Spring Centered and Detent Spool Operators. See Figure 2**

14.Stripper Bolt	1	391-1432-022	391-1432-021	391-1402-452
15.Centering Spring	1	391-3581-608	391-3581-633	391-3581-330
16.Spring Guides	2	391-1642-045	391-1642-013	391-1642-161
17.Detent Sleeve	1	391-3283-015	391-3283-008	391-3384-310
18.Detent Balls	2	391-0282-010	391-0282-009	391-0282-011
19.Detent Spring	1	391-3581-130	391-3581-015	391-3581-316
20.Detent Poppet Retainer	1	391-2583-008	391-2583-006	391-3384-311
21.Detent Spacer	1	.....	.....	391-3782-208

## 4

## Valve Disassembly Instructions

Reference exploded view and parts list on page 2 and 3 for work section detail.

### Step 1 - Valve Bank

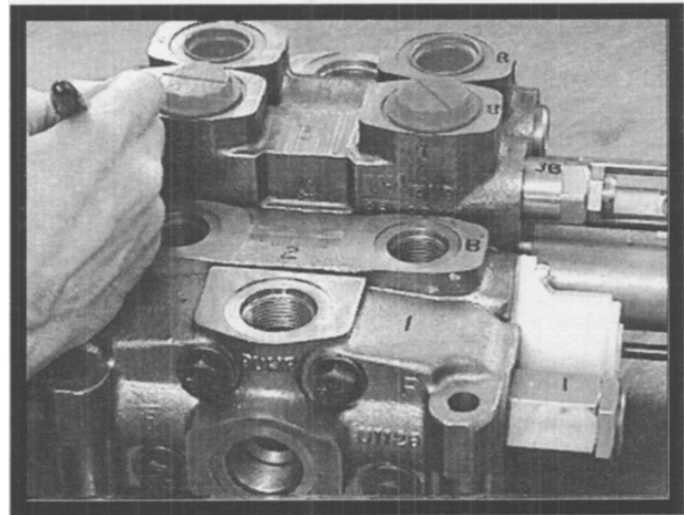
This step is the most critical in the disassembly procedure. It should be followed closely to ensure that the valve bank is properly reassembled after repairs have been made.

With a waterproof, quick-drying marker, mark each casting with a sequential number. Start by marking the inlet casting with the #1 and finish by marking the outlet with the highest number.

Next, mark the port boss closest to the back cap on each work section with a "B" (for back cap end).

Then, mark the port boss closest to the spool clevis on each work section with a "C" (for clevis end).

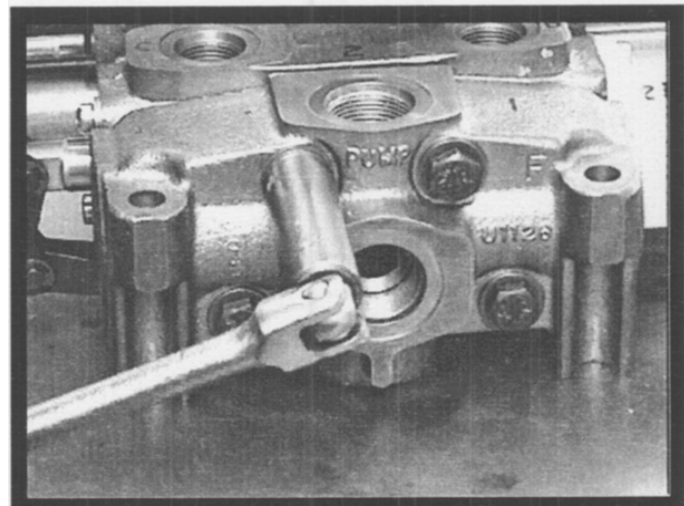
Finally, if relief valves are removed from the valve bank they must be marked with the corresponding number of the casting and port location (B or C) from which they were removed. Inlet and mid-inlet relief valves are marked with a casting number only.



### Step 2 - Tie Bolts

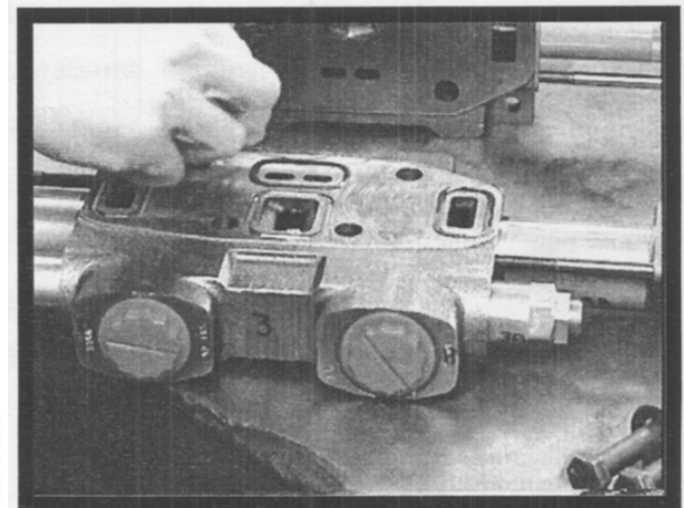
Remove the four, tie bolts that hold the bank together and separate the sections.

**NOTE: VA valve tie bolts thread into the outlet casting. VG valve tie bolts pass through the entire bank, requiring washers and hex nuts to be fastened at both ends of the bolt.**



### Step 3 - Section Seals

The inlet, mid-inlet and each parallel work section have four, section seals, (Fig. 1, items 1 & 2) on the downstream, mating face. Series work sections and the VA/VG35 split flow mid inlets have three section seals on the downstream mating face, (Fig. 1, items 1 & 3.) These section seals should be removed and discarded.

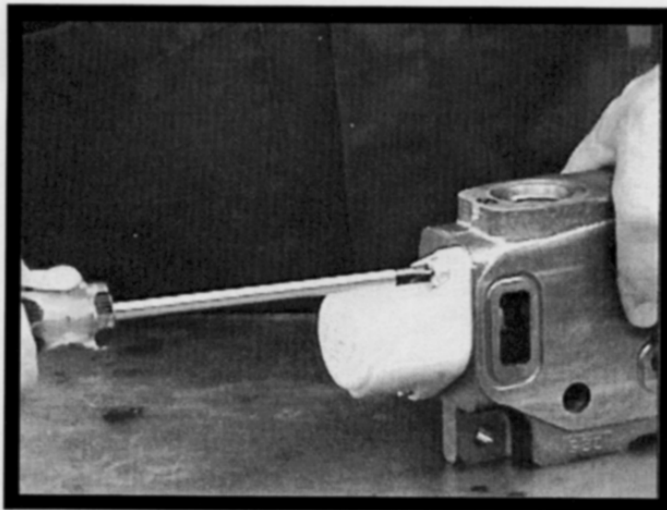


**REMINDER: ALL WORK MUST BE PERFORMED IN A CLEAN AREA.**



## Valve Disassembly Instructions

5



### Step 4 - Valve Back Cap

Using a large, Phillips-head screwdriver, remove the two, cap screws (Fig. 1, item 4) which fasten the back cap to the work section. Lightly tap the end of the screwdriver handle with a hammer to break adhesive. Remove the back cap (Fig. 1, item 5).

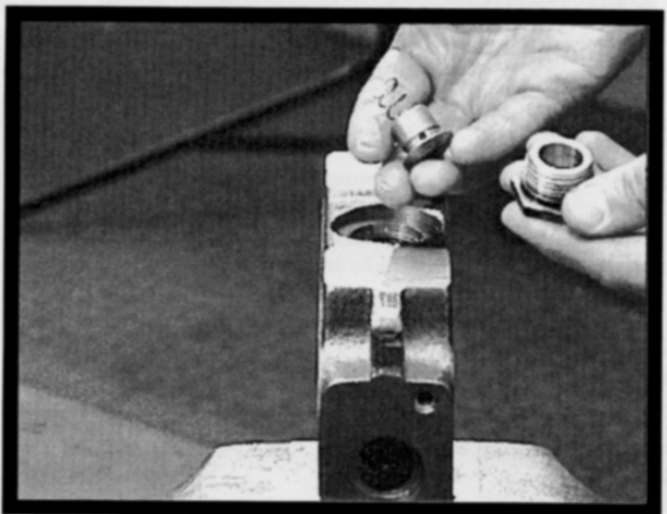


### Step 5 - Control Spool and Seals

Grasp the spring end of the spool with a clean, lint-free cloth and pull the spool out of the housing using a twisting motion. Generally, the rear, retainer plate (Fig. 1, item 6 ) back-up ring (Fig. 1, item 7) and spool seal (Fig. 1, item 8) will come out with the spool.

**CAUTION:** For detented spool models, be careful not to remove the detent poppet sleeve (Fig. 2, item 17) unless it is to be serviced.

Using a large, Phillips-head screwdriver, remove the two, retainer-plate screws (Fig. 1, item 9) from the spool clevis end of the work section. Lightly tap the end of the screwdriver handle with a hammer to break the adhesive. Remove the two, retainer plates (Fig. 1, item 6) the back-up ring (Fig. 1, item 7) and the spool seal (Fig. 1, item 8). Tag or mark with the appropriate, work section identification number. (See Step 1.) Spool seals (Fig. 1, item 8) and back-up rings (Fig. 1, item 7) should be discarded.



### Step 6 - Transition Check

The transition check is located in the bottom center of the work section housing. Carefully clamp the work section in a vise with ports down. Do not clamp on the machined surface. Remove the check-valve cap (Fig. 1, item 10) and its O-ring seal (Fig. 1, item 11). Discard the seal. Remove the check spring (Fig. 1, item 12,) and the check-valve poppet (Fig. 1, item 13).

**NOTE:** Only cylinder work sections (ports blocked in neutral) have a transition check. Motor sections have only a cap plug.

## 6 Valve Disassembly Instructions

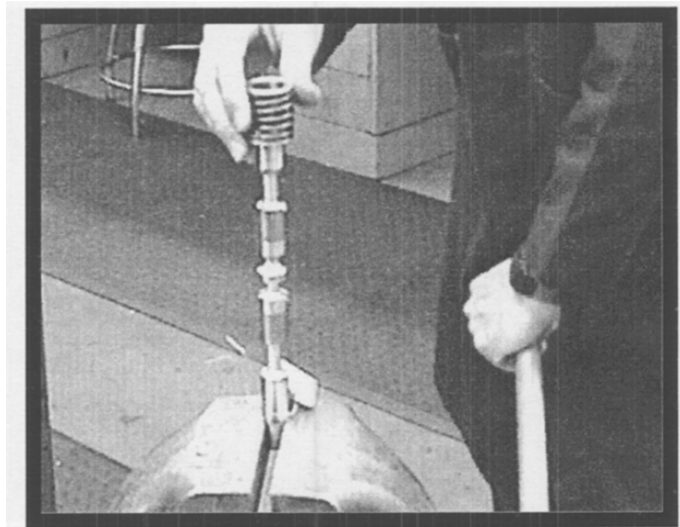
### Spool Disassembly Spring Centered Spool

The spring assembly should not be removed from the spool unless these parts need to be replaced. Once the spool is free of the work section housing, it must be handled carefully to avoid damage. Place the spool vertically in a soft-jawed vise, clamping on the flat, spool clevis, and remove the stripper bolt (Fig. 1, item 14) with a wrench.

Lightly tap the stripper bolt with a hammer and a punch to help break the adhesive. Cautious application of heat may be required to free the stripper bolt, since an anaerobic thread adhesive was used during its assembly.

**CAUTION: Too much heat may distort the spool.**

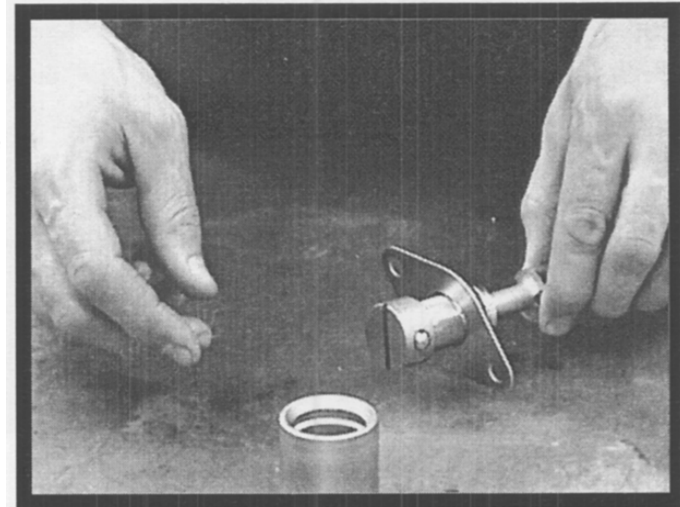
As the stripper-bolt threads disengage, the spring (Fig. 2, item 15) and spring guides (Fig. 2, item 16) will release abruptly from the spool.



### Detent Spool

The detent assembly should not be removed from the spool unless these parts need to be replaced. Wrap the detent sleeve (Fig. 2, item 17) with a clean, lint-free cloth. Grip the cloth-covered sleeve and pull firmly. As the sleeve moves backwards, the detent balls (Fig. 2, item 18) and the detent spring (Fig. 2, item 19) will release abruptly. The cloth should capture these parts and prevent their loss.

Next, clamp the spool in a soft-jawed vise and remove the detent poppet retainer (Fig. 2, item 20). Place an undersized bar through the detent ball bore to serve as a wrench. Lightly tap the detent poppet retainer with a hammer and a punch to help break the adhesive. Cautious application of heat may be required again, since an anaerobic adhesive was also used in the detent retainer assembly.



**CAUTION: Too much heat may distort the spool!**

## CLEANING, INSPECTION, AND REPAIR

1. Inspect the spool bore, transition check seat and spool from each section for deep scratches, gouges or excessive wear. If any of these conditions exist, replace the section. Minor, surface damage on the control spool and check poppet can be carefully polished away with a very fine, crocus cloth.

2. Examine the machined surfaces of the valve housing for nicks and burrs that could cause leakage between sections. Lightly stone these surfaces to remove any rough spots.

**CAUTION: A shallow-milled relief area extends across the O-ring face of the valve housing. This should not be stoned or ground off!**

3. Wash all parts thoroughly in a cleaning solvent and blow dry before beginning reassembly. Pay special attention to the number and letters marked on the parts in Step 1. If any marks are removed during cleaning, remark immediately.

4. Clean adhesive from threads of spool, stripper bolt, housing, cap screws and hex nut with Loctite™ Chisel Gasket Remover.



## Valve Assembly Instructions

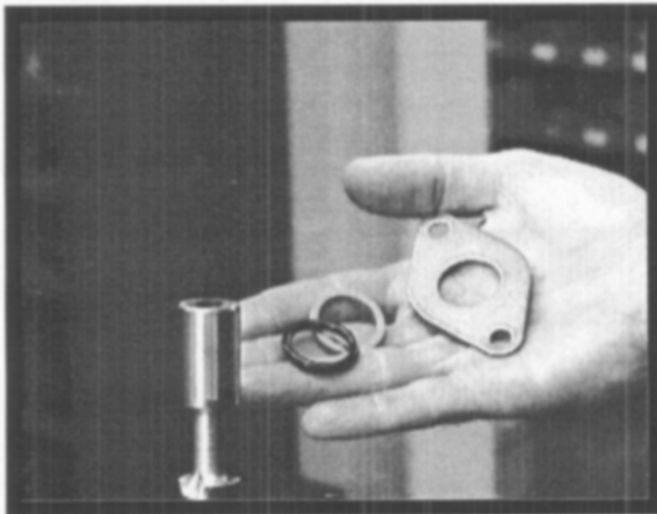
7

### Preparation of Parts

Spray the threads of the new stripper bolt (Fig. 2, item 14) tapped-threaded spool end, all screws and screw holes on both ends of the housing with LOCQUIC Primer Grade NF™ and let dry.

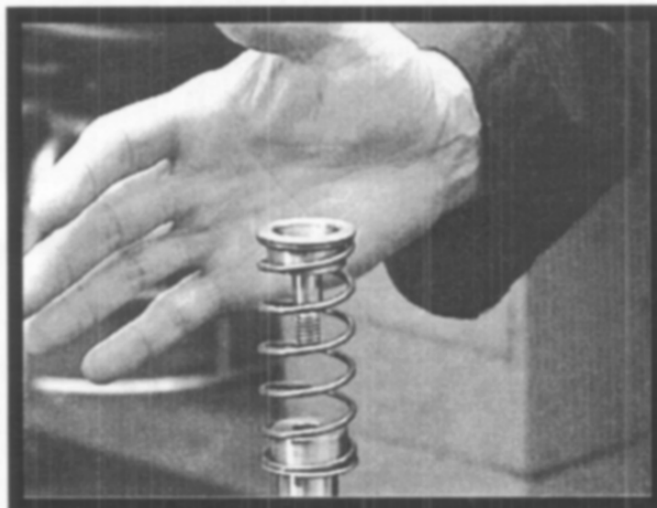
**CAUTION: Failure to follow the recommended assembly instructions can result in poor performance or product malfunction. Product should be thoroughly tested to ensure proper operation before the valve is placed back into service.**

### Spring Center Spool Assembly



#### Step 1 - Spool Assembly-Spring Centered

Clamp the flat, clevis end of the control spool in a soft jawed vise. Apply Parker Super-O-Lube™ to the spool seal (Fig. 1, item 8 ) and slide it onto the end of the spool away from the clevis. Slide on the back-up ring (Fig. 1, item 7) and retainer plate (Fig. 1, item 6). Position these items onto the spool, so that they do not interfere with the spool operator mechanism during assembly. Do not allow the O-ring to come in contact with the sharp edge of the spool notches.



#### Step 2 - Attach Spring Guides and Spring

Apply 2 - 3 drops of Loctite 262™ or equivalent anaerobic adhesive near the middle of the female threads in the spool. Assemble the spring guides (Fig. 2, item 16) centering spring (Fig. 2, item 15 ) and stripper bolt (Fig.2, item 14, ) onto the spool (Reverse of Step 7). Torque the stripper bolt to 175 in. lbs. +/-4 in. lbs.

**CAUTION: Follow the adhesive manufacturer's instructions for proper cleaning and curing. Failure to clean and prepare parts properly may result in assembly failure!**

**CAUTION: Care must be taken to ensure that the spring retainer is not pinched under the shoulder bolt during assembly. This can result in burrs that may cause spool binding. Check for binding by compressing the spring and guides or by rotating the spring guide nearest the housing.**

Lightly coat the centering spring with high- temperature grease to prevent rusting. Set the spool assembly aside and let it cure for a minimum of 1 hour. After curing, test the stripper bolt to make certain it can withstand 125 in. lbs. of breakaway torque.

## Valve Assembly Instructions

### Detent Spool Assembly

#### Step 1 - Spool Assembly-Detent

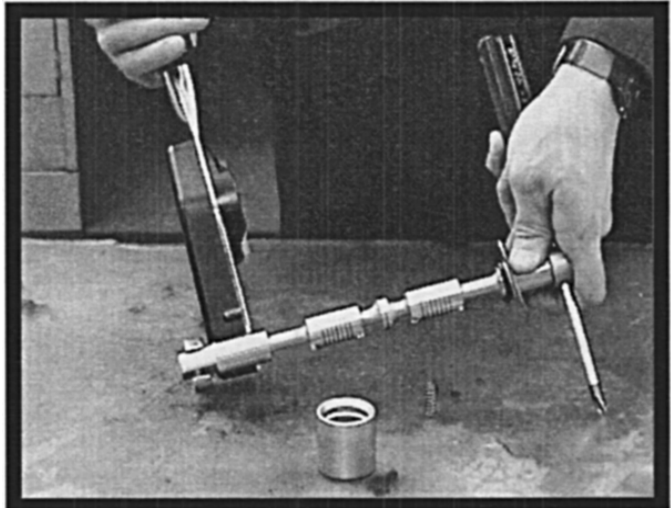
Apply Parker Super-O-Lube™ to the spool seal (Fig. 1, item 8) and slide it onto the spool. Slide the back-up ring (Fig. 1, item 7) and one, retainer plate (Fig. 1 item 6) onto the spool. Position these items onto the spool, so that they do not interfere with the spool operator mechanism during assembly. Do not allow the O-ring to come in contact with the sharp edge of the spool notches. Apply 2 - 3 drops of Loctite 262™ or an equivalent, anaerobic adhesive near the middle of the female threads in the spool.

**CAUTION: Follow the adhesive manufacturer's instructions for proper cleaning and curing. Failure to clean and prepare parts properly may result in assembly failure.**



#### Step 2 - Spool Assembly-Detent

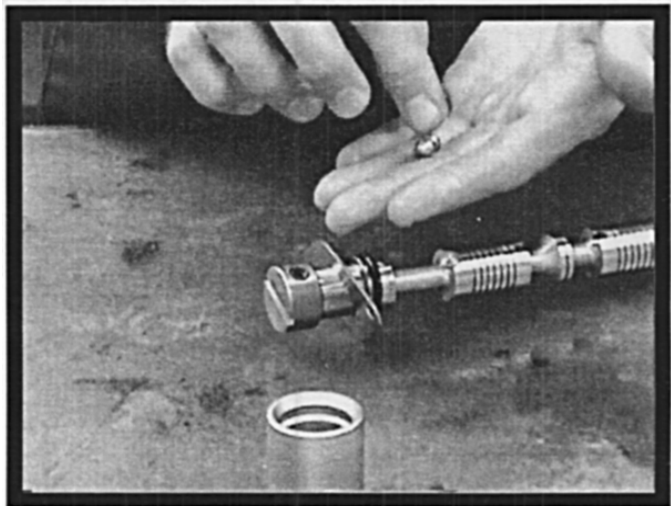
Thread the detent ball retainer (Fig. 2, item 20) into the spool end. Torque the detent ball retainer to 175 in. lbs. +/- 4 in. lbs.. This can be accomplished by using a crows-foot socket on the flats of the clevis, and holding the spool by inserting a round, steel rod or screwdriver through the hole in the ball retainer.



#### Step 3 - Detent Balls and Spring

Next, lightly coat the detent balls (Fig. 2, item 18) detent spring (Fig. 2, item 19) and entire inside diameter of the detent sleeve (Fig. 2, item 17) with high-temperature grease.

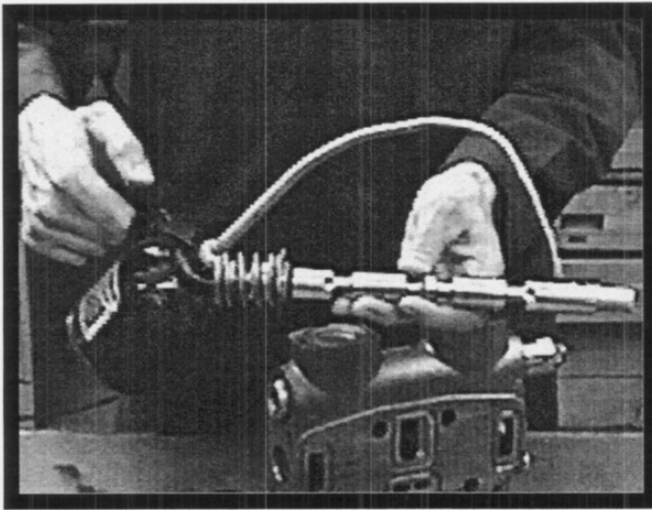
Insert the detent spring into the through hole in the detent ball retainer. Place the steel balls on the ends of the spring. Compress the balls and spring, then slip on the detent sleeve. (Note: The detent sleeve is not symmetrical; one end of the sleeve has a lead-in chamfer. This chamfer must face the spool clevis when assembled.) Move the detent sleeve to the neutral or middle position to prevent the subassembly from separating during subsequent steps.





## Valve Assembly Instructions

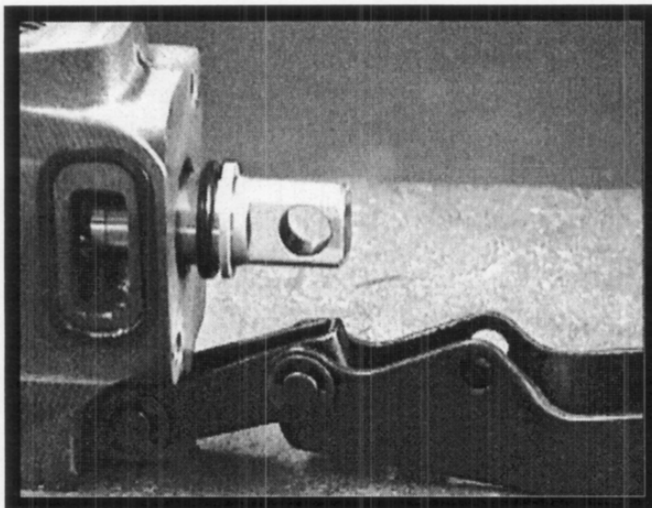
9



### Step 1 - Spool Subassembly

Apply 2 - 3 drops of Loctite 262™ or equivalent to the fillister screw holes on both ends of the housing.

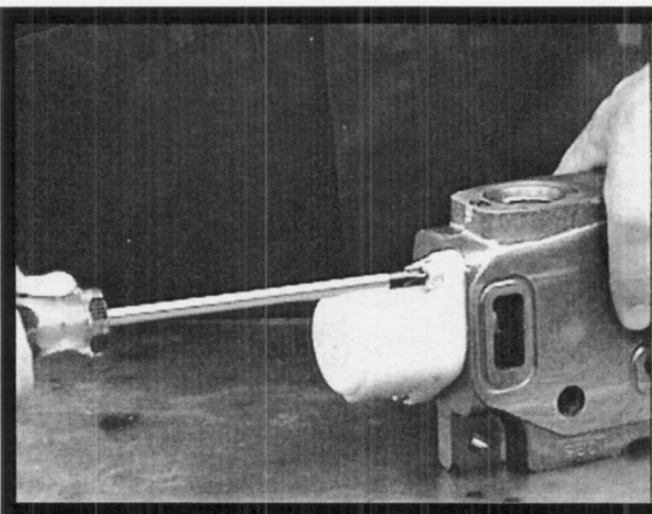
Apply a light coating of clean, hydraulic oil to the valve spool. Carefully insert the spool assembly into the housing. Use caution to avoid causing burrs. Be careful not to pinch, roll or damage the seals. Make sure that the spool and housing are in the proper orientation (see Step 1, page 6 disassembly).



### Step 2 - Spool Seal and Back up

Apply Parker Super-O-Lube™ to the spool seal (Fig. 1, item 8) and slide it onto the spool. Slide on the back-up ring (Fig. 1, item 7). Push both items into the counter-bore until they bottom out.

Assemble the two, front, retainer plates (Fig. 1, item 6) using the two short, fillister screws (Fig. 1, item 9). Check retainer plates for proper alignment. Tighten to a final torque of 34 in. lbs. +/- 2 in. lbs..



### Step 3 - Back cap

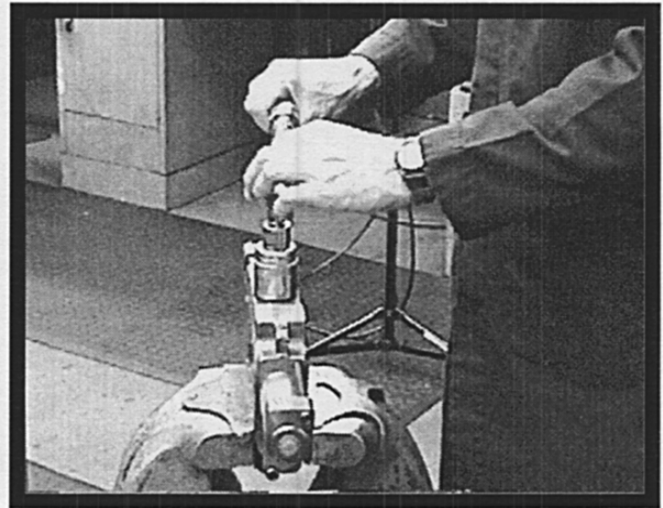
Install the back cap using the two, long, fillister screws (Fig. 1, item 4). Tighten to a final torque of 34 in. lbs. +/- 2 in. lbs.

**Caution: Excessive torque will damage the back cap ears!**

## Valve Assembly Instructions

### Step 4 - Install Transition Check

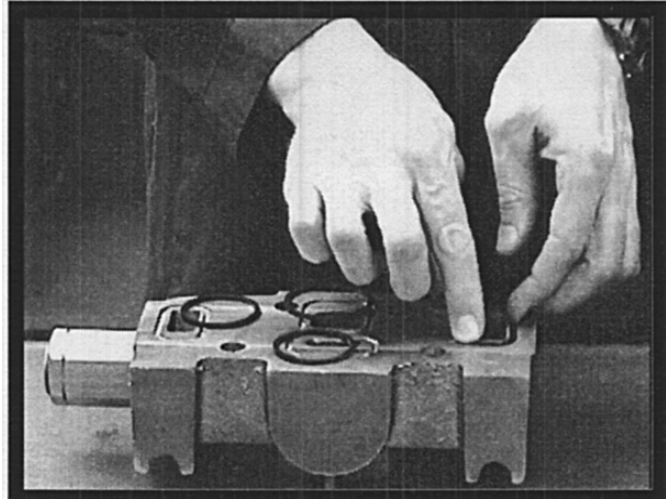
Inspect transition check components for cleanliness. Install check poppet (Fig. 1, item 13) into the transition check cavity. Align the check spring (Fig. 1, item 12) square to the poppet, then carefully place the check cap (Fig. 1, item 11) over the poppet and spring. Turning by hand, engage several threads. Tighten to a final torque of 75 ft. lbs. +/-4ft. lbs..



### Step 5 - Relief Valves

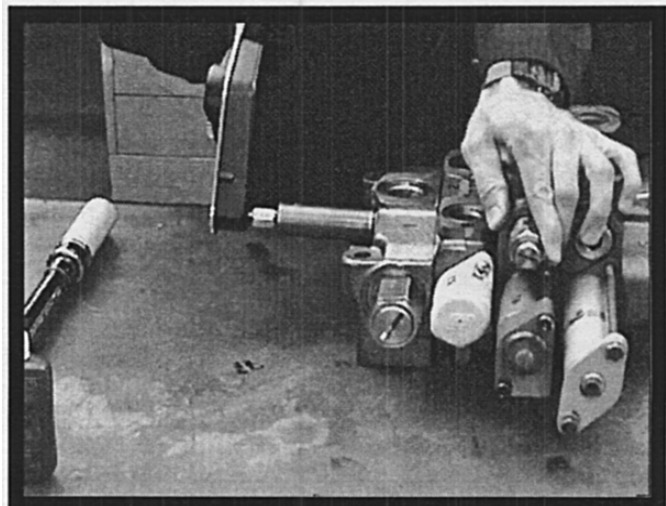
Return all relief valves to their proper positions and torque to 75 ft. lbs.

Install new, section seals. Place section seals (Fig. 1, items 1 & 2, or items 1 & 3) in the proper grooves. Make certain seals stay in their grooves during assembly.



### Step 6 - Install Tie Bolts

Slide the tie bolts through the inlet casting. If cap screws are used, place a washer on the cap screw prior to installation. Place the valve sections on the tie bolts in their proper sequence (see Step 1, page 4). Turning by hand, engage several threads in the outlet. If it is a VG series assembly, assemble nut and washer to either end of the stud and follow above instructions. Torque the tie bolts in a cross-corner pattern.



#### Tie Bolt Torque Values

VA20 - 29 ft. lbs. (348 in. lbs.)

VG20 - 42 ft. lbs. (504 in. lbs.)

VA35 - 34 ft. lbs. (408 in. lbs.)

VG35 - 75 ft. lbs. (900 in. lbs.)

VG80 - 150 ft. lbs. (1800 in. lbs.)



28

### Troubleshooting

TROUBLE	PROBABLE CAUSE	REMEDY
Oil leaks between sections	Pinched, blown or missing section seal	Replace section seal
	Stud fasteners not correctly torqued	Replace section seals and re-torque
	Mounting plate not level	Loosen mounting bolts and shim as required
	Contamination/burrs on seal	Clean seal groove, replace section seal
Oil leaks at either end of spool	Over-pressurized tank core	Correct high, back-pressure condition
	Worn or damaged spool seals	Replace seals and seal retainers
Spring - centered spools do not return to neutral	Broken centering spring	Replace centering spring
	Misalignment of operating linkage	Check linkage for mechanical binding
	Foreign particles in system	Clean valve and system
Load will not hold	Cylinder leaking or worn	Check cylinder - repair
	Port relief valve not holding	Remove and clean or replace
	Spool or housing scored or worn excessively	Replace section
Load drops when spool moved from neutral	Dirt or foreign particles lodged between check-valve poppet and seat	Disassemble, clean & reassemble
	Scored or sticking check-valve poppet	Replace poppet
No motion, slow, or erratic system operation	Worn pump	Check flow & pressure
	Defective cylinder or motor	Repair or replace
	Low-reservoir oil level	Add oil to specifications
	Clogged suction strainer	Clean or replace
	Suction line restricted	Check lines
	Relief valve not properly set	Check pressure setting
	Relief valve poppet or seat scored & sticking open	Replace relief valve
	Valve spool not shifted to full stroke	Check spool linkage travel