

TONG SPECIFICATIONS		
MAX TORQUE (FT LBS/NM)	100,000	135,580
TONG ARM LENGTH (INCH/CM)	49.6	126.0
BACKUP ARM LENGTH (INCH/CM)	38.8	97.0
MASS (LBS/KG)	7150	3243
TORQUE (FT LBS/NM, ESTIMATED)		
AT PRESSURE (PSI/BAR)	2,700 ^C	186
HI/HALF	9,200	12,473
HI/FULL	19,600	26,570
LOW/ HALF	50,100	67,926
LOW/FULL	100,000	135,580
SPEED (RPM, ESTIMATED)		
AT FLOW RATE (GPM/LPM)	60	227
HI/HALF	27.5	
HI/FULL	14	
LOW/ HALF	5	
LOW/FULL	2.5	

REVISIONS				
REVISION	ECO NUMBER	ECO DESCRIPTION	ECO COMPLETED BY	ECO COMPLETED DATE
A	N/A	INITIAL RELEASE	N/A	N/A
B	17-0081	REMOVE (1) MK14000-06, ADD (1) MK14000-05, INCREASING HEIGHT BY 8"	J. KELLY	2017
C	ECN17-0097	CORRECTED SPECIFICATION TABLE ARM LENGTH 38.8 WAS 38.2	S. PANCHAL	4/24/2017
D	17-0130	REPLACE (2) 1003071 W/ (2) 1004918; ADD (1) 101-5499; REMOVE (2) 4XHX7-S062 & (1) 09-9228; ADD (1) 02-E0564, (1) CM4565, (1) 1431, & (1) 1431-C	M.BUDDEN	6/22/2017
-	N/A	REMOVED TABLE	R. RAHMAN	1/15/2018

UNLESS OTHERWISE SPECIFIED:		PROPRIETARY STATEMENT		DESCRIPTION	
1. DIMENSIONS ARE IN INCHES		THIS DOCUMENT IS THE PROPERTY OF MCCOY CORPORATION AND IS CONSIDERED CONFIDENTIAL. THIS INFORMATION MAY NOT BE USED, DISCLOSED, COPIED, OR REPRODUCED IN ANY FORM, WITHOUT THE EXPRESS WRITTEN CONSENT OF MCCOY CORPORATION.		ASSEMBLY, TONG, 14000-100K x 15000 LJBU, COMPRESSION, HRR	
2. TOLERANCES: ANGULAR: ± 1° FRACTIONAL: ± 1/16 TWO PLACE DECIMAL: ± 0.02 THREE PLACE DECIMAL: ± 0.005		DRAWN		S.PANCHAL 02/01/2017	
3. IDENTIFY P/N & MAIL P.O. USING 1/8 TO 1/4 ETCHED LETTERS, DENOTED BY "X"		CHECKED		R.RAHMAN 02/01/2017	
4. REMOVE BURRS & SHARP EDGES WITH 1/64x45° MAX		APPROVED		R.RAHMAN 02/01/2017	
5. MACHINED FILET RADII SHALL BE 1/32		THIRD ANGLE PROJECTION		WEIGHT	
6. FINAL SURFACE ROUGHNESS AVG. (Ra) SHALL BE ≤ 250 MICRONS		7. ^C DENOTES CRITICAL DIMENSION: 100% INSPECTION REQUIRED		7047 LBS.	
8. A TRIANGLE DENOTES A REVISION		9. INTERPRET DRAWING PER ASME Y14.5-2009		MATERIAL	
				N/A	
				REV D	
				SHEET 1 OF 2	

RELEASED FOR PRODUCTION

ITEM	QTY	P/N	DESCRIPTION
1	1	CLE14000DP13	ASSEMBLY, TONG, 14-100K
2	1	BUCS15000	BACKUP, DRILL PIPE, 15 IN
3	1	MK14000-05	MOUNTING KIT, TALL, CLE14000DP02
4	1	101-9143	ASSEMBLY, REVERSING PIN
5	1	CRSS22069	ASSEMBLY, MANIFOLD, DRAIN
6	1	CP230-1B-6S	VALVE, REDUCING/RELIEVING, PRESSURE
7	2	1004918	ASSEMBLY, VALVE, DETENT, SUN HYDR
8	1	101-9128	WELDMENT, MOUNTING, VALVE PACKAGE
9	1	101-9126	WELDMENT, MOUNTING, VALVE PACKAGE
10	3	09-5114	5/8"
11	2	09-1230	BOLT, HEX, 5/8-11, 1 1/2, STEEL, GR 8, ZINC
12	2	02-E0493	CHECK VALVE, PILOT OPERATED, CP410-1
13	2	CM4565	CHECK VALVE, 1/4 FNPT
14	1	101-5499	PLATE, SUPPORT
15	1	02-E0564	FITTING, 1/4, 1/32 ORIFICE, PARKER; 4 XHX7-S .031 ORIFICE
16	1	1003716	DISCONNECT, 16 STATION FEMALE, 1/4 FORB
17	1	1003740	ASSEMBLY, MULTI DISCONNECT, JUMPER
18	1	101-7552	TAG, MAKE-BREAK, TONG
19	1	101-7553	TAG, CLAMP-RELEASE, BACKUP
20	1	101-7554	TAG, LIFT-LOWER, LIFT CYLINDER
21	1	101-7555	TAG, MAKE-BREAK, BACKING PIN
22	1	101-7556	TAG, CLOSE-OPEN, DOOR
23	1	101-7557	TAG, HIGH-LOW, GEAR
24	14	09-0403	SCREW, SOCKET, SOCKET CAP, M6X1, 20 STEEL
25	1	101-9144	PLATE, MOUNT VALVE
26	1	1003072	VALVE, PVG, 7 BANK, 120/32
27	1	2070	VALVE, RELIEF
28	1	LSV1-6T-N	VALVE, SHUTTLE
29	1	BAC-5M25RCFF	GAUGE, 2 1/2, 5K, 1/4 MNPT
30	1	101-0727	MANIFOLD, HYDRAULIC, DOOR SWITCH
31	2	86052	CARTRIDGE, LOGIC ELEMENT
32	2	101-7252	SPACER, VALVE, ASSEMBLY
33	1	101-9147	WELDMENT, MOUNTING, QUICK COUPLING
34	1	101-5121	PLATE, HYDRAULIC SUPPORT, INLET
35	1	101-5122	PLATE, HYDRAULIC SUPPORT, OUTLET
36	1	101-5588	TAG, RETURN
37	1	101-5589	TAG, INLET
38	1	02-E0187	CLAMP, PIPE, 1 1/4
39	2	02-E0186	CLAMP, PIPE, 1
40	1	101-9150	WELDMENT, BULK HEAD
41	1	09-1252	BOLT, HEX, 5/8-11, 6 1/2, GR 8, ZINC, FULLY THREADED
42	1	101-9151	SPACER, ID.656 X OD1.25 X 4.5T
43	1	55151-S1	PLATE, MOUNT, GAUGE
44	1	101-9153	TAG, HIGH-LOW, MOTOR
45	18	09-5106	WASHER, SPRING LOCK, REGULAR, 3/8, 17/25, 0.035-0.125, STEEL, GR 8, ZINC
46	2	09-1046	3/8"-16 UNC - 1"
47	2	09-1553	3/8"-16 UNC - 1-1/2"
48	8	09-5806	NUT, HEX, 3/8-16, STEEL, GR 8, ZINC
49	6	09-1048	BOLT, HEX, 3/8-16, 1 1/4, GR 8, ZINC, FULLY THREADED
50	4	09-6016	NUT, HEX, 5/16-18, STEEL, GR 8, ZINC
51	10	09-5104	WASHER, SPRING LOCK, REGULAR, 5/16, 29/50, 0.035-0.125, STEEL, GR 8, ZINC
52	4	HBOLT 0.3125-18x1.5x1.5-N	HEX BOLT
53	4	1/2-13 UNC - 1.5	WASHER, SPRING LOCK, REGULAR, 1/2, 43/50, 0.125-0.25, STEEL, GR 8, ZINC
54	4	09-5110	5/16"-18 UNC - 3.5"
55	2	09-9185	BOLT, HEX, 7/16-14, 1 1/4, STEEL, GR 8, ZINC
56	4	09-1108	HELICAL SPRING LOCK WASHER
57	4	7/16	PLATE, SUPPORT, PIPE
58	1	101-9154	PLATE, SUPPORT, PIPE
59	1	101-7855	PLATE, SUPPORT, PIPE
60	1	1431	FITTING, 1/2 COUPLING, 1/2 NPTF, QUICK DISCONNECT
61	1	1431-C	CAP, QUICK DISCONNECT, 1/2

B

D

D

D

D

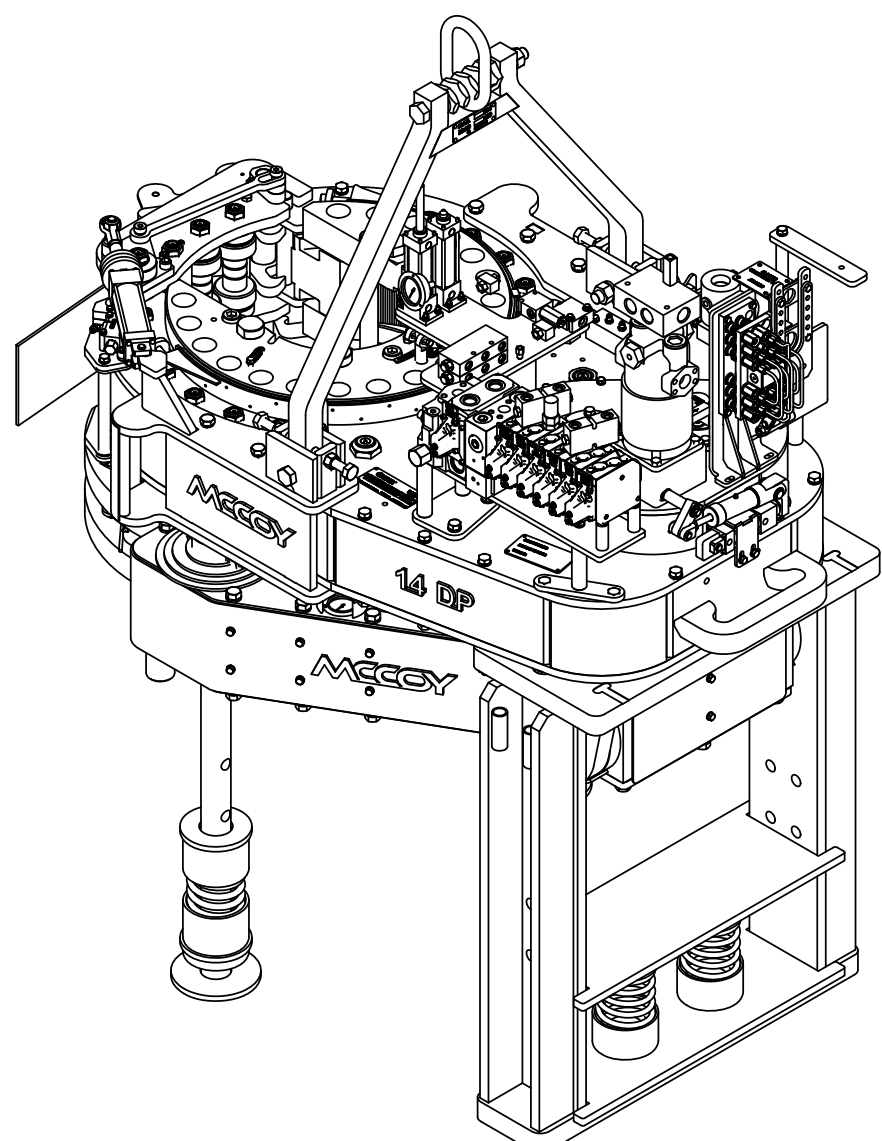

D

D

DESCRIPTION			
ASSEMBLY, TONG, 14000-100K x 15000 LJBU, COMPRESSION, HRR			
SIZE	PART NO.	REV	
B	80-140-100-15D-111-7S-00	D	
MATERIAL		SHEET 2 OF 2	
N/A			