

DPU660-11 SPECIFICATIONS	
MAXIMUM OPERATING PRESSURE	3000 PSI / 207 BAR
MAXIMUM DIESEL ENGINE OUTPUT	114 HP
MAXIMUM HYDRAULIC FLOW CAPACITY	60 GPM / 227 LPM
HYDRAULIC RESERVOIR CAPACITY	140 GALLON / 530 L
FUEL TANK CAPACITY	42 GALLON / 159 L
STARTER TYPE	AIR START
OIL REQUIREMENT	AW-68
SPECIAL FEATURES	2 STAGE GEAR PUMP
	COOLER

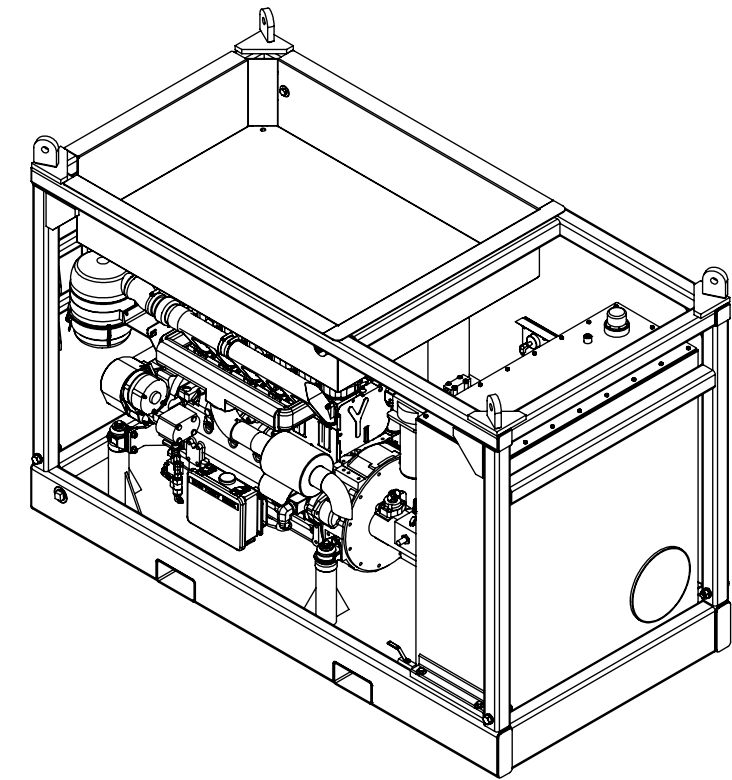
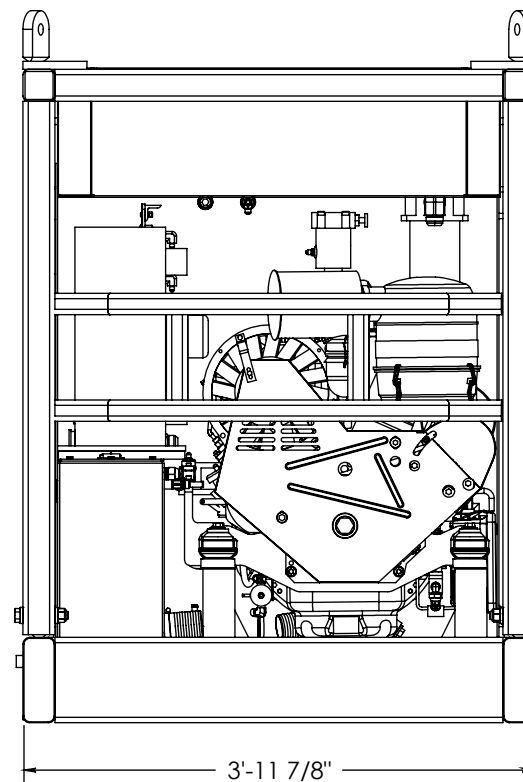
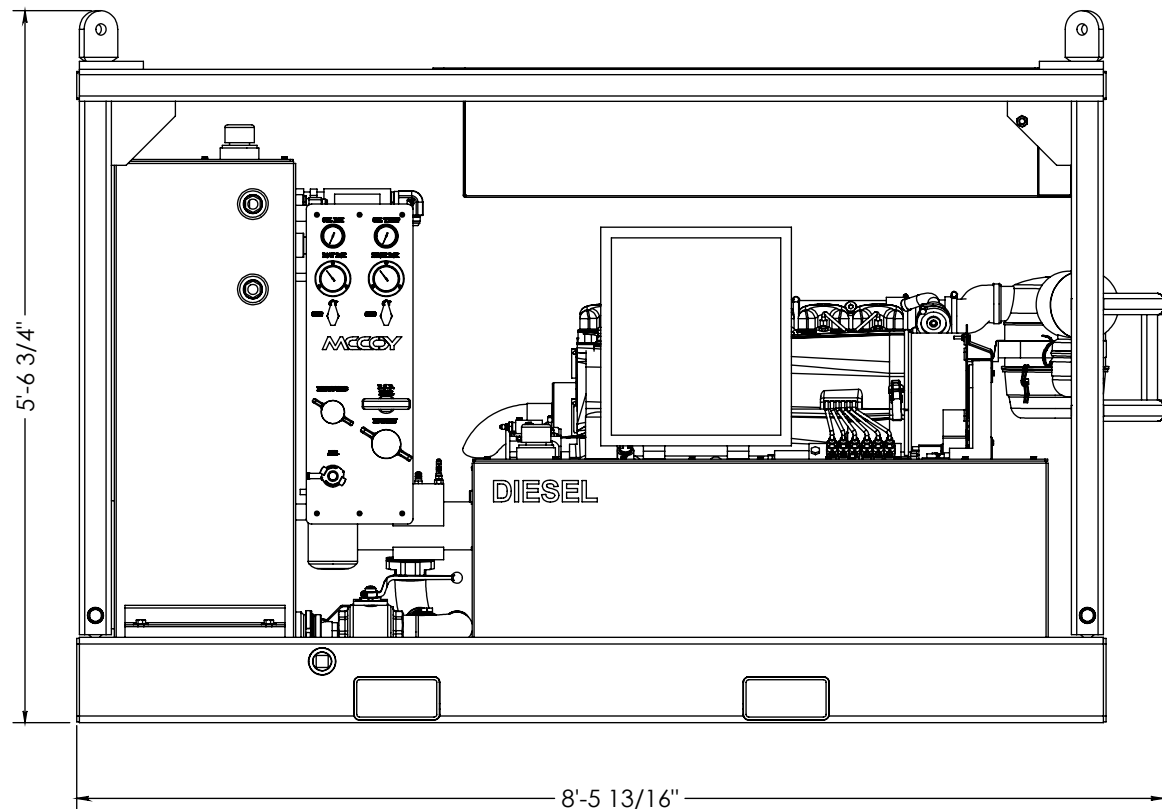

REVISIONS				
REVISION	ECO NUMBER	ECO DESCRIPTION	ECO COMPLETED BY	ECO COMPLETED DATE
A	14-0682	PART ADDITION	R.CENAC	12/19/2014
B	16-0173	BOM UPDATE; REMOVED KITS	M.BUDDEN	8/11/2016
C	17-0101	REMOVE (1) 1441, (1) 1446; ADD (1) 1670; ADD DRAWING SPECIFICATION SHEET; ADDED (2) H40-24; REPLACE 7040HL-011 W/ 7040HL-011-02	M.BUDDEN	5/5/2017

UNLESS OTHERWISE SPECIFIED:		PROPRIETARY STATEMENT		DESCRIPTION	
1. DIMENSIONS ARE IN INCHES		THIS DOCUMENT IS THE PROPERTY OF MCCOY CORPORATION AND IS CONSIDERED CONFIDENTIAL. THIS INFORMATION MAY NOT BE USED, DISCLOSED, COPIED, OR REPRODUCED IN ANY FORM, WITHOUT THE EXPRESS WRITTEN CONSENT OF MCCOY CORPORATION.		ASSEMBLY, POWER UNIT, DIESEL, 6 CYLINDER, WITH COOLER	
2. TOLERANCES: ANGULAR ± 1° FRACTIONAL ± 1/16 TWO PLACE DECIMAL ± 0.02 THREE PLACE DECIMAL ± 0.005		DRAWN S.MCCROSKEY 2/19/2013		SIZE PART NO.	
3. IDENTIFY P/N & MAIL P.O. USING 1/8 TO 1/4 ETCHED LETTERS; DENOTED BY "X"		CHECKED B.PEARCE		B DPU660-11	
4. REMOVE BURRS & SHARP EDGES WITH 1/64x45° MAX		APPROVED B.PEARCE		MATERIAL	
5. MACHINED FILET RADII SHALL BE 1/32		THIRD ANGLE PROJECTION		N/A	
6. FINAL SURFACE ROUGHNESS AVG. (Ra) SHALL BE ≤ 250 MICRONS		WEIGHT 4180 LBS.		REV C	
7. DIMENSIONS IN PARENTHESES ARE CRITICAL DIMENSIONS; 100% INSPECTION REQUIRED				SHEET 1 OF 7	
8. A TRIANGLE DENOTES A REVISION					
9. INTERPRET DRAWING PER ASME Y14.5-2009					

RELEASED FOR PRODUCTION

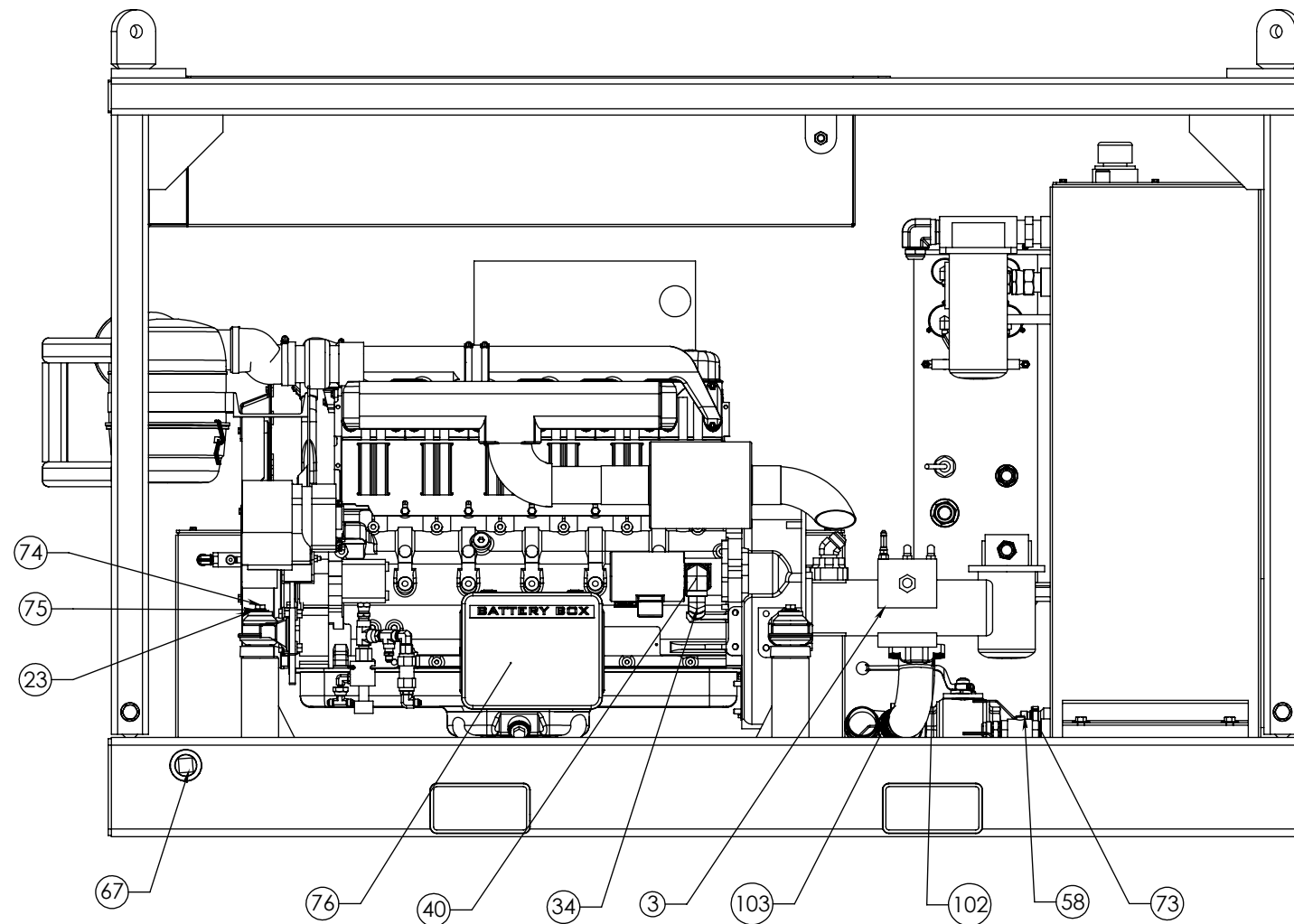
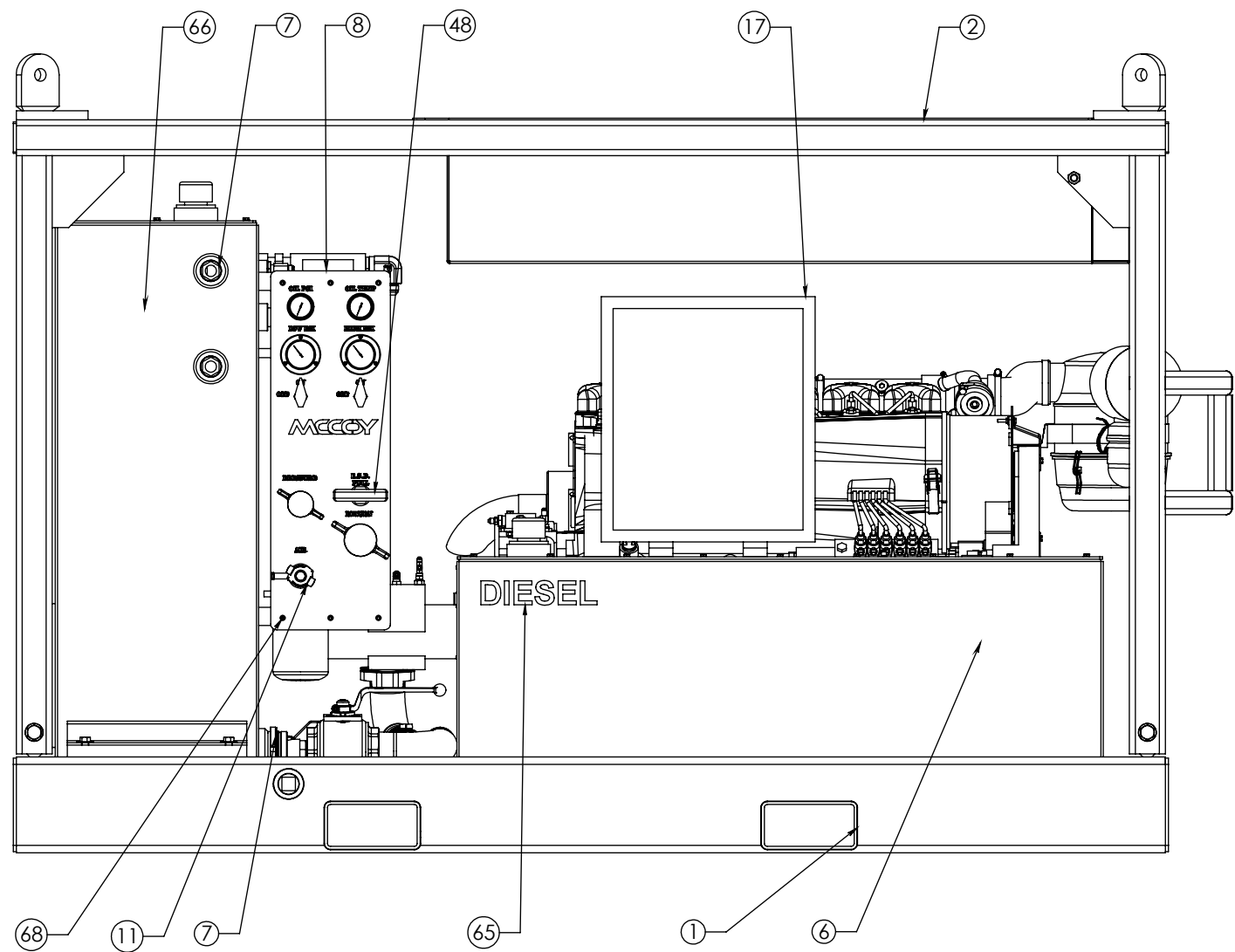

DESCRIPTION			
ASSEMBLY, POWER UNIT, DIESEL, 6 CYLINDER, WITH COOLER			
SIZE	PART NO.	REV	
B	DPU660-11	C	
MATERIAL	N/A	SHEET 3 OF 7	

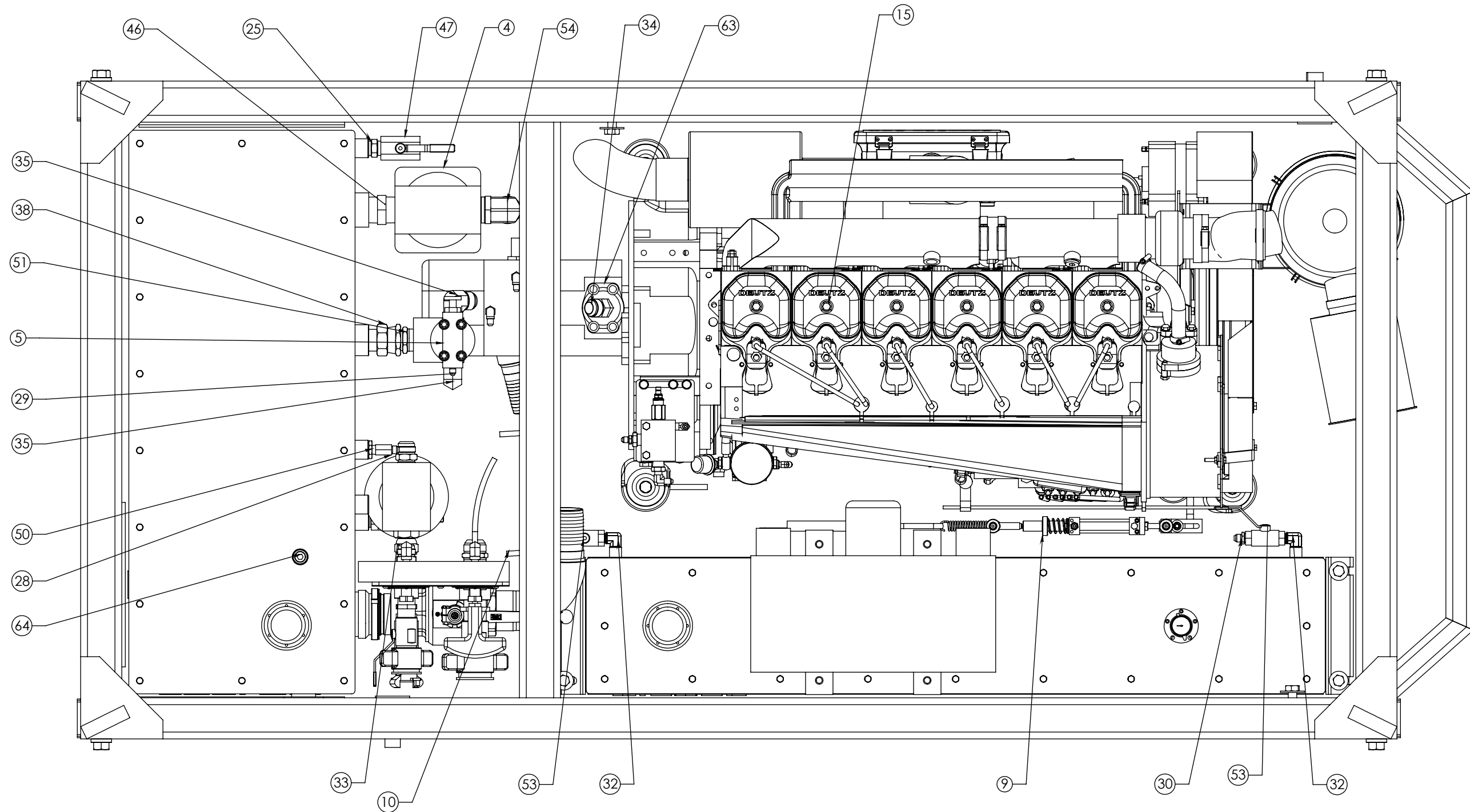

DESCRIPTION		
	ASSEMBLY, POWER UNIT, DIESEL, 6 CYLINDER, WITH COOLER	
SIZE	PART NO.	REV
B	DPU660-11	C
MATERIAL	N/A	SHEET 4 OF 7

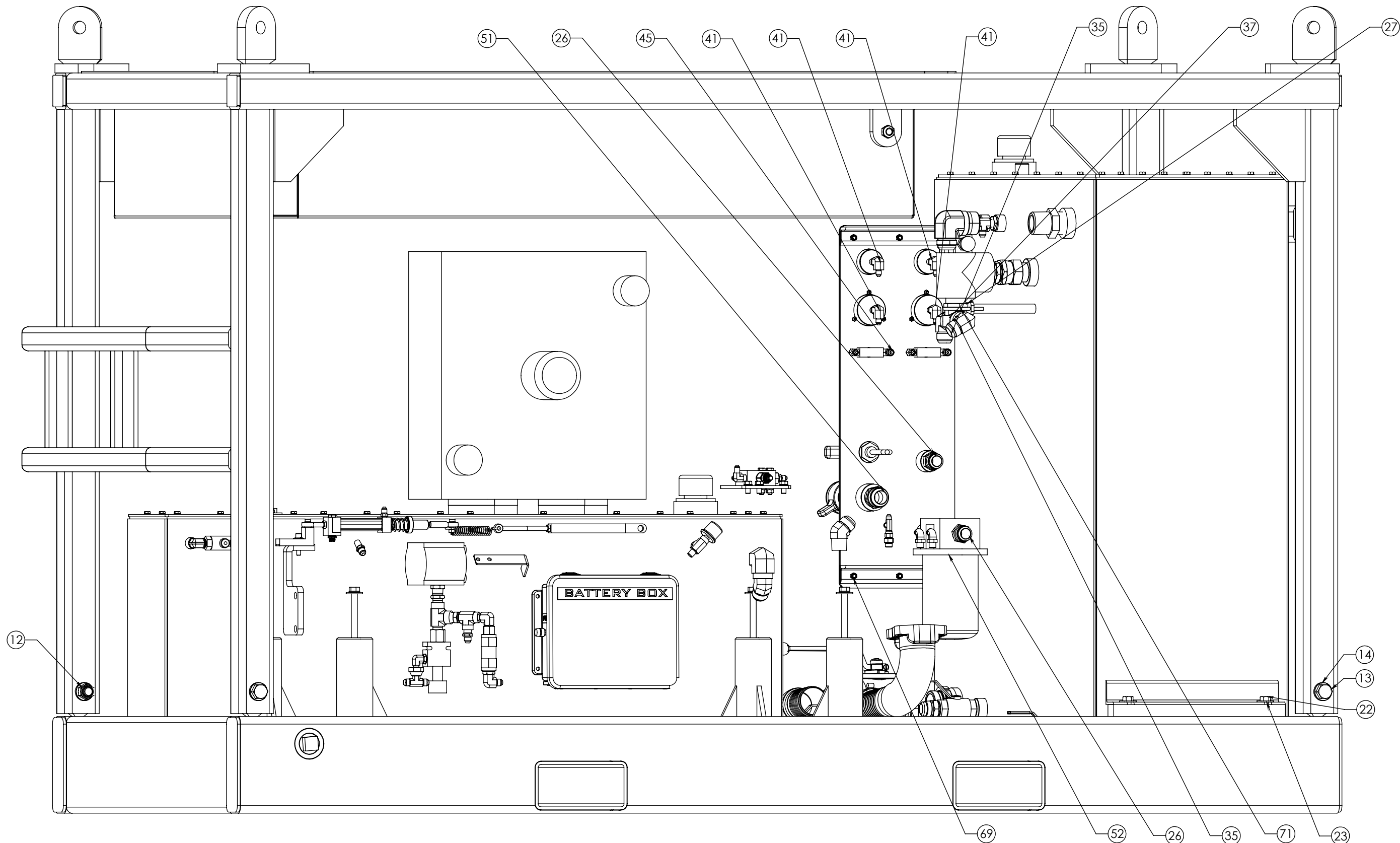

DESCRIPTION			
ASSEMBLY, POWER UNIT, DIESEL, 6 CYLINDER, WITH COOLER			
SIZE	PART NO.	REV	
B	DPU660-11	C	
MATERIAL	N/A	SHEET 5 OF 7	

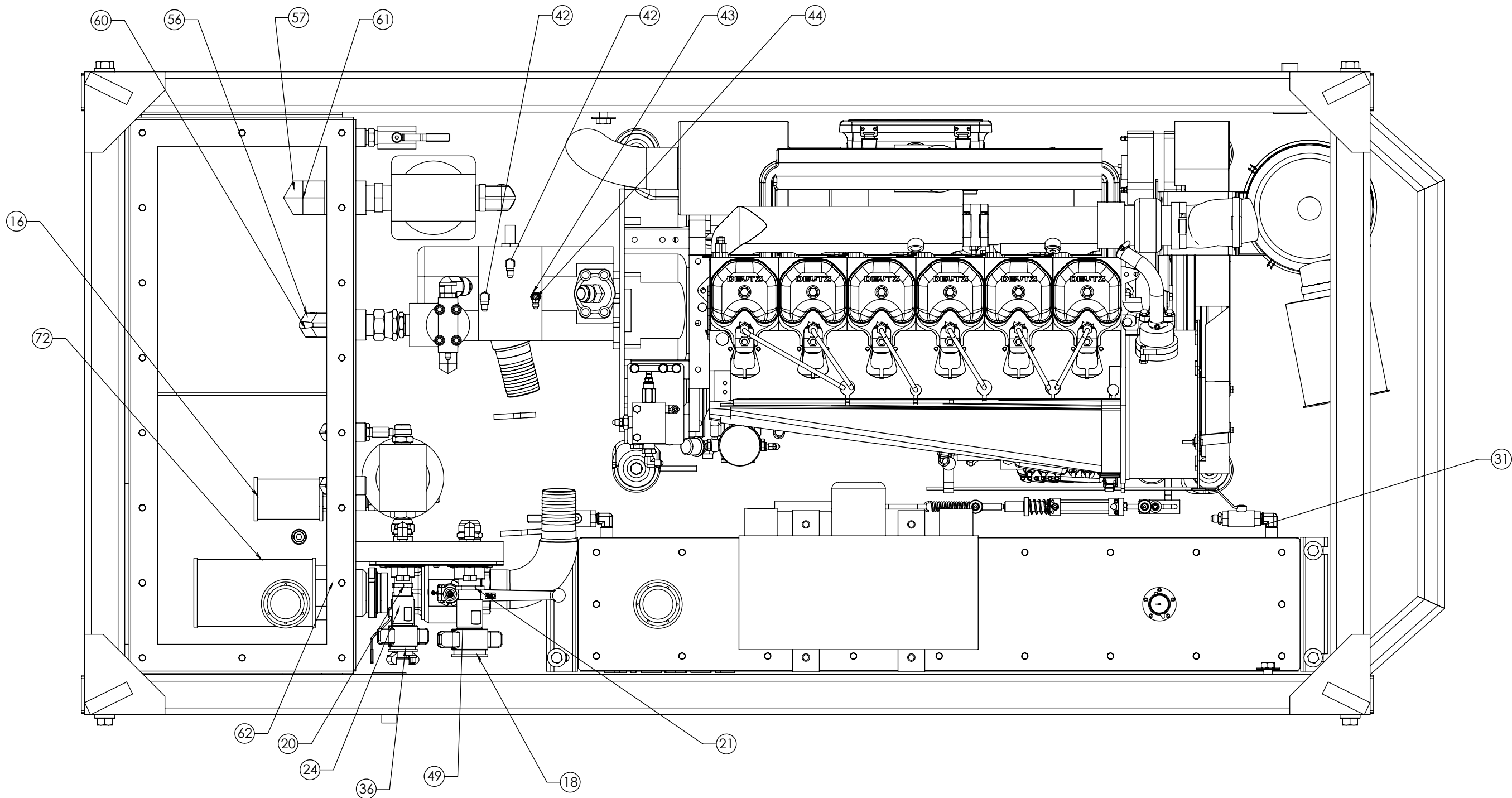

DESCRIPTION			
ASSEMBLY, POWER UNIT, DIESEL, 6 CYLINDER, WITH COOLER			
SIZE	PART NO.	DPU660-11	REV
B			C
MATERIAL		N/A	SHEET 6 OF 7

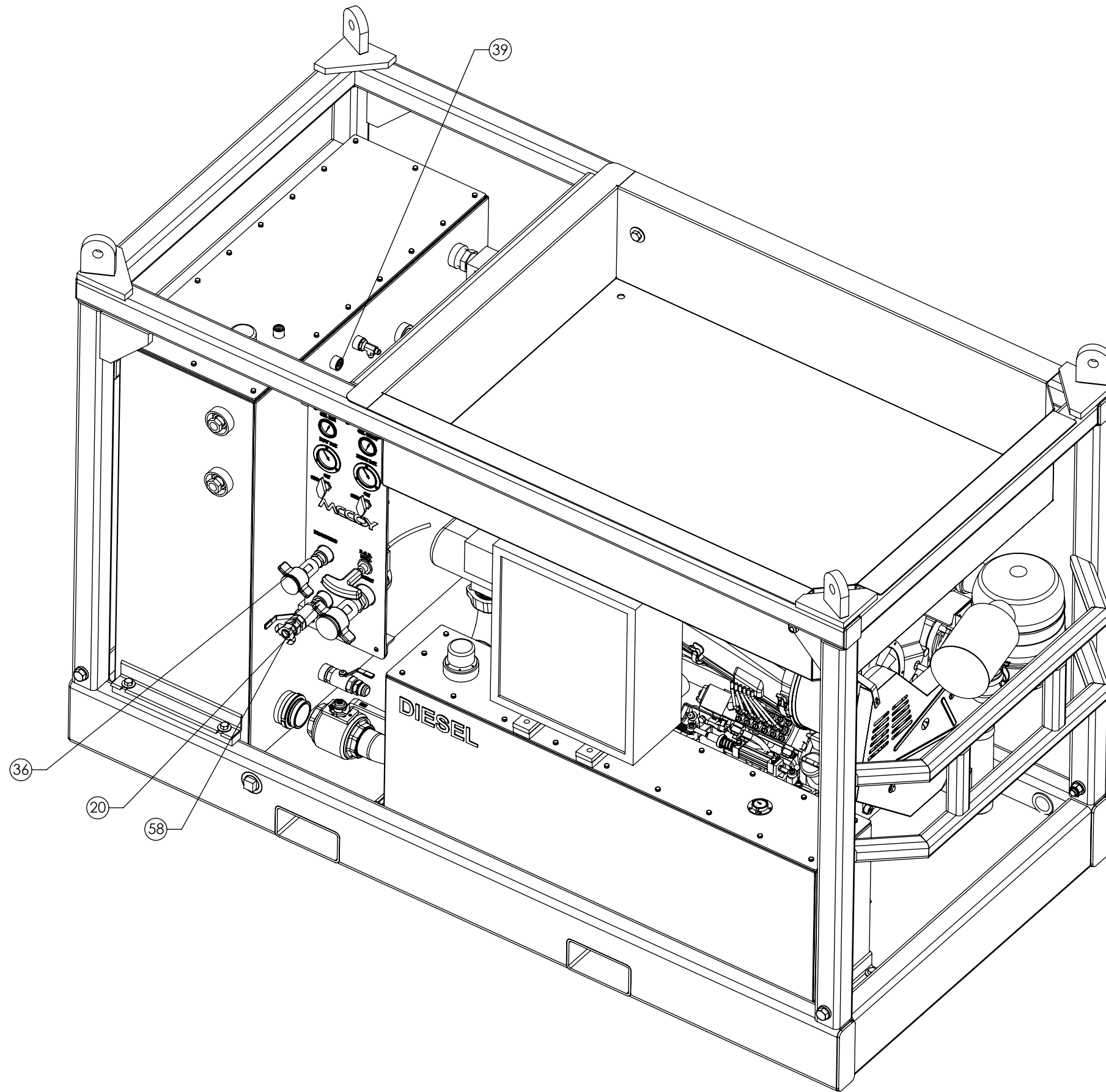

DESCRIPTION			
ASSEMBLY, POWER UNIT, DIESEL, 6 CYLINDER, WITH COOLER			
SIZE	PART NO.		REV
B	DPU660-11		C
MATERIAL		N/A	SHEET 7 OF 7