

TONG SPECIFICATION		
MAX TORQUE (FT · LBS/N · M)	60,000	81,360
ARM LENGTH (INCH/CM)	55.0	139.7
MASS (LBS/KG)	3,900	1,771
TORQUE (FT · LBS/N · M, ESTIMATED)		
AT PRESSURE (PSI/BAR):	2,000	138
Hi/Full	9,167	12,430
Lo/Full	60,000	81,360
SPEED (RPM, ESTIMATED)		
AT FLOW RATE (GPM/LPM):	60	227
Hi/Full	27.7	
Lo/Full	4.2	

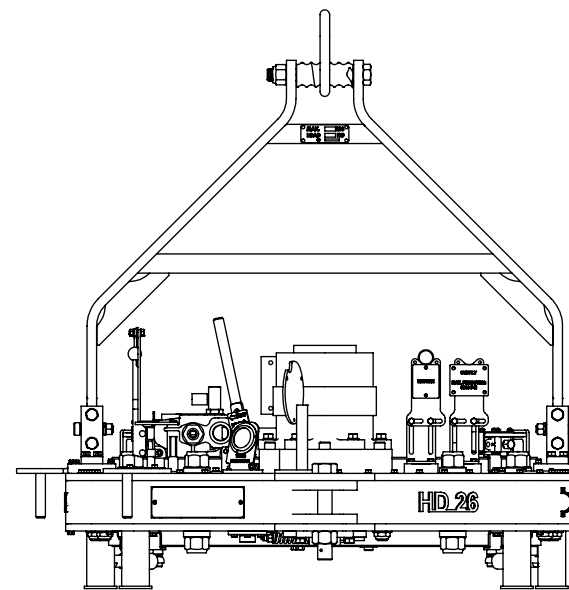
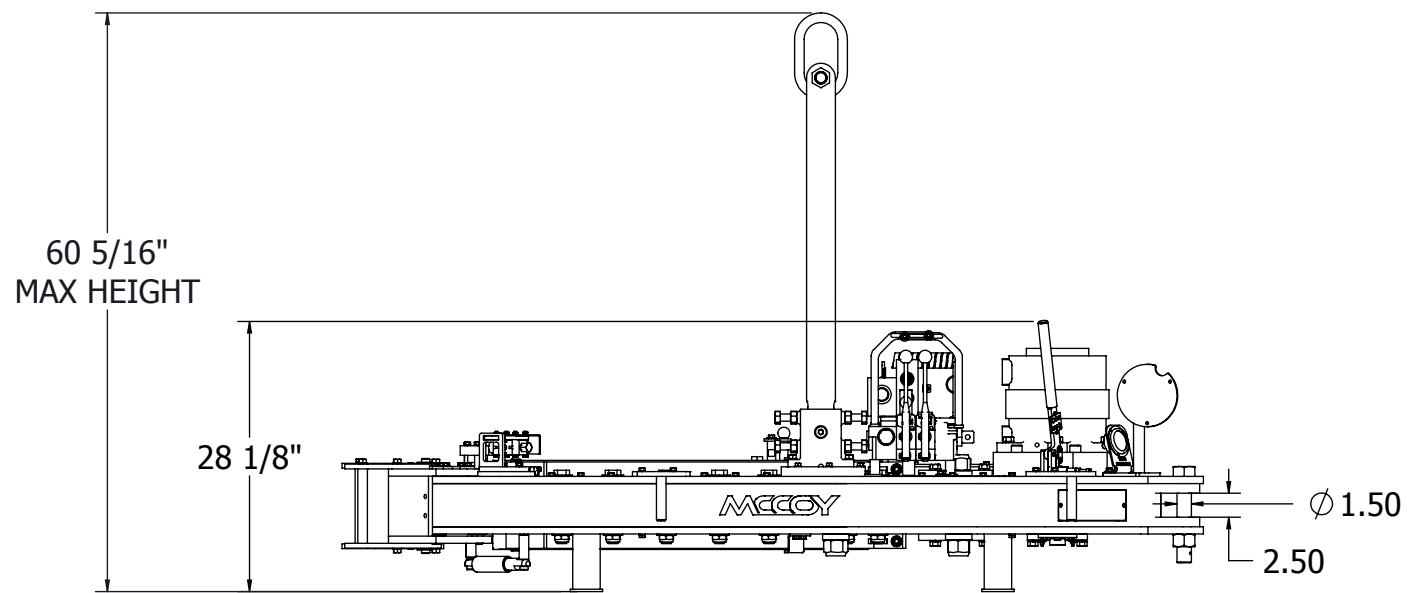

REVISIONS				
REVISION	ECO NUMBER	ECO DESCRIPTION	ECO COMPLETED BY	ECO COMPLETED DATE
5	ECN-002382	REPLACED SHOULDER BOLT WITH 02-1016(X2)	SP	02/FEB/2015
A	ECN-002545	REPALCED 101-1530 WITH 101-1694, 101-6122 WITH 101-2865, ADDED 1483-500-00-07 AND 101-8614	T.YIMER	11/JAN/2016
B	ECN-002585	REMOVED 101-5277(X1), 101-0023(X1), 101-0022(X3), 101-1138(X1), 02-9222-PLUG (X1), 02-9222-ORING(X1) AND ADDED 101-4585FPL(X1), 02-9222(X1)	S. PANCHAL	03/29/2016
C	ECN16-0243	REMOVED 02-0120 (X1), ADDED 02-9228(X1), 02-9022(X1) & 02-E0564(X1)	S. PANCHAL	3/28/2017
X	N/A	REMOVED TABLE	R. RAHMAN	1/12/2018

UNLESS OTHERWISE SPECIFIED:		PROPRIETARY STATEMENT			
1. DIMENSIONS ARE IN INCHES 2. TOLERANCES: ANGULAR ± 1° FRACTIONAL ± 1/16 TWO PLACE DECIMAL ± 0.02 THREE PLACE DECIMAL ± 0.005 3. IDENTIFY P/N & MAIL P.O. USING 1/8 TO 1/4 ETCHED LETTERS, DENOTED BY "X" 4. REMOVE BURRS & SHARP EDGES WITH 1/64x45° MAX 5. MACHINED FILET RADII SHALL BE 1/32 6. FINAL SURFACE ROUGHNESS AVG. (Ra) SHALL BE ≤ 250 MICROINCHES 7. DIMENSIONS IN CRITICAL DIMENSION: 100% INSPECTION REQUIRED 8. A TRIANGLE DENOTES A REVISION 9. INTERPRET DRAWING PER ASME Y14.5-2009		THIS DOCUMENT IS THE PROPERTY OF MCCOY CORPORATION AND IS CONSIDERED CONFIDENTIAL. THIS INFORMATION MAY NOT BE USED, DISCLOSED, COPIED, OR REPRODUCED IN ANY FORM, WITHOUT THE EXPRESS WRITTEN CONSENT OF MCCOY CORPORATION.			
DRAWN	SHP	08/02/2011	DESCRIPTION		
CHECKED	MRM		ASSEMBLY, TONG, 26000-60K, CC		
APPROVED	MRM	11/06/2011	SIZE	PART NO.	REV
THIRD ANGLE PROJECTION			WEIGHT	80-1903-3	C
			3684.04 LBS.	MATERIAL	SHEET 1 OF 2

RELEASED FOR PRODUCTION

ITEM	QTY	P/N	DESCRIPTION	MATERIAL	ITEM	QTY	P/N	DESCRIPTION	MATERIAL
1	1	80-1910	ASSEMBLY, TONG, HD26-60K	N/A	61	1	02-E0204	WRAP, SPIRAL, OD 1.60" X ID 1.40"	N/A
2	1	1482-11A-00M	WELDMENT, DOOR	N/A	62	1	101-6860	WELDMENT, VALVE GUARD	N/A
3	1	1482-11B-00M	WELDMENT, DOOR	N/A	63	1	101-6861	WELDMENT, VALVE GUARD	N/A
4	2	1482-11-03	ROLLER, SUPPORT	STEEL, 4140 HTR	64	6	09-5806	NUT, HEX, 3/8-16, STEEL, GR 8, ZINC	
5	4	02-0096	BEARING, BALL, 6206	Steel, Mild	65	1	09-5840	NUT, HEX, 1 1/2-6, STEEL, GR 8, ZINC, DOUBLE CHAMFER	
6	4	1482-11-06	TUBE, SPACER, DOOR ROLLER	STEEL, 1020 HR	66	1	09-5808	NUT, HEX, 3/8-16	
7	2	1482-11-08	TUBE, SPACER, SUPPORT ROLLER	STEEL, MILD	67	2	09-1048	BOLT, HEX, 3/8-16, 1 1/4, GR 8, ZINC, FULLY THREADED	
8	2	1482-11-04	SHAFT, ROLLER, DOOR SUPPORT	STEEL, 4140 HTR	68	2	09-1009	BOLT, HEX, 1/4-20, 1 1/4, GR 8, ZINC, FULLY THREADED	*
9	4	1482-11-05	PLATE, LOCK, PIN	STEEL, 44W	69	17	09-1046	3/8"-16 UNC - 1"	
10	2	1482-11A-12	SPRING, COMPRESSION	STEEL WIRE, ASTM 229	70	10	09-1553	3/8"-16 UNC - 1-1/2"	
11	1	101-1333	WELDMENT, LATCH	N/A	71	2	09-1557	BOLT, HEX, 3/8-16, 1 3/4, STEEL, GR 8, ZINC, FULLY THREADED	
12	1	101-1488	WELDMENT, LATCH	N/A	72	8	09-5106	WASHER, SPRING LOCK, REGULAR, 3/8, 17/25, 0.035-0.125, STEEL, GR 8, ZINC	N/A
13	2	1482-11A-10	PLATE, LID, DOOR LOCK	STEEL, 44W	73	6	09-5110	1/2"	N/A
14	1	101-1927	WELDMENT, HANDLE, DOOR	N/A	74	2	02-1016	SCREW, SHOULDER, SOCKET HEAD, 5/8, 3 1/4, STEEL, GR 8, ZINC	
15	1	101-1926	WELDMENT, HANDLE, DOOR	N/A	75	4	09-0049	BOLT, SHOULDER, SOCKET HEAD, 5/8-11, 3/4, ALLOY STEEL	
16	2	1482-12-08	WASHER, SPACER	STEEL, 44W	76	1	101-1694	WELDMENT, GAUGE MOUNT	*
17	2	02-0520	BUSHING, Ø.875 X Ø.625 X .5L	MANGANESE BRONZE (C86300)	77	1	101-2865	MOUNT WELDMENT, TORQUE GAUGE, KT 8625 BJ	*
18	1	1482-11A-07	PLATE, LATCH HANDLE	STEEL, 44W	78	1	1483-500-00-07	BRACKET, MOUNTING, GAUGE	Stainless Steel, 316
19	1	1482-11B-06	PLATE, HANDLE, DOOR	STEEL, 44W	79	1	101-8614	PLATE, PRESSURE GAUGE MOUNT BASE	Steel, 44W
20	1	1037-42	SPACER, CLUTCH	STEEL, MILD	80	43	09-5106	WASHER, SPRING LOCK, REGULAR, 3/8, 17/25, 0.035-0.125, STEEL, GR 8, ZINC	
21	1	1426-7	PLATE, MOUNT, MOTOR	STEEL, 44W	81	2	09-1042	BOLT, HEX, 3/8-16, 1/2, GR 8, ZINC, FULLY THREADED	
22	1	87-0158	MOTOR, RINEER, 125 SERIES, 113 CID, SPLINED SHAFT	N/A	82	4	09-1058	BOLT, HEX, 3/8-16, 3, GR 8, ZINC, FULLY THREADED	
23	1	101-5780	WELDMENT, LEVER, SHIFT	N/A	83	5	09-5006	WASHER, PLAIN, FLAT, WIDE, 3/8, 1, 0.035-0.125, STEEL, ZINC	
24	1	02-0120	LINKAGE, SHIFTING	N/A	84	4	09-2052	HX-SHCS 0.375-16x1.75x1.75-NZ	
25	1	02-0018	BALL, SHIFTING	N/A	85	4	09-1054	BOLT, HEX, 3/8-16, 2, GR 8, ZINC, FULLY THREADED	
26	1	997-0-64	SPRING, COMPRESSION	STEEL WIRE, ASTM 229	86	12	09-1046	BOLT, HEX, 3/8-16, 1, GR 8, ZINC, FULLY THREADED	
27	1	DAV35-M-S-B	ASSEMBLY, DVA35 VALVE	N/A	87	3	09-1184	BOLT, HEX, 1/2-13, 4 1/2, GR 8, ZINC, FULLY THREADED	
28	3	101-1322	WELDMENT, POST, VALVE MOUNT	N/A	88	3	0.3125-Clevis Pin		
29	1	08-9062	VALVE, HYDRAULIC NEEDLE	N/A	89	1	09-1044	BOLT, HEX, 3/8-16, 3/4, GR 8, ZINC, FULLY THREADED	
30	1	10-9068	FITTING, 1 1/4 MORB, 1/2 FORB, STRAIGHT	N/A	90	1	09-1108	BOLT, HEX, 7/16-14, 1 1/4, GR 8, ZINC	
31	1	101-0727	MANIFOLD, HYDRAULIC, SAFETY DOOR	DURABAR	91	6	09-5114	WASHER, SPRING LOCK, REGULAR, 5/8, 1 5/64, 0.125-0.25, STEEL, GR 8, ZINC	
32	1	02-0245	GAUGE, PRESSURE, FLANGE	N/A	92	6	09-0081	BOLT, HEX, 5/8-11, 2 1/2, GR 8, ZINC, FULLY THREADED	
33	2	101-0023	PLATE, SUPPORT, HYDRAULIC	STEEL, 44W	93	5	09-2298	SCREW, SOCKET CAP, SOCKET, 3/4-10, 3, GR 8, ZINC	
34	1	1037-36	BOLT, CAGE PLATE	STEEL, 1020 CR	94	4	09-5110	WASHER, SPRING LOCK, REGULAR, 1/2, 43/50, 0.125-0.25, STEEL, GR 8, ZINC	
35	1	1482-39	PIN, BACKING	STEEL, 4140 HTR	95	6	09-1168	BOLT, HEX, 1/2-13, 1 1/4, GR 8, ZINC, FULLY THREADED	
36	1	1482-54	PLATE RETAINER, BACKING PIN	STEEL, 44W	96	2	09-4999	WASHER, PLAIN, FLAT, WIDE, 5/8, 1 3/4, 0.125-0.25, STEEL, ZINC	
37	1	02-0017	KNOB	N/A	97	12	09-1007	BOLT, HEX, 1/4-20, 1, GR 8, ZINC, FULLY THREADED	
38	3	HITCH PIN .0930 X 1.125	PIN, HITCH, 0.0930 DIA, 1.125 LG	N/A	98	12	09-5102	WASHER, SPRING LOCK, REGULAR, 1/4, 31/64, 0.035-0.125, STEEL, GR 8, ZINC	
39	1	10-0084	CARTRIDGE, RELIEF VALVE, 2001-2500 PSI	N/A	99	1	02-9222	PLUG, COUNTERSUNK, 1" ORB MALE	N/A
40	2	08-1625	CARTRIDGE, PILOT TO OPEN CHECK, LKHCXDN	N/A	100	1	02-9022	CHECK VALVE, 1/4 NPTF	N/A
41	1	101-3586	GUIDE, BRAKE BAND	STEEL, 44W	101	1	02-9228	VALVE, CHECK, 1/2" NPT	N/A
42	1	101-3595	BOLT, HEAVY HEX, 1 1/2-6, 9, STEEL, GR8, DRILLED END	N/A	102	1	02-E0564	FITTING, 1/4, 1/32 ORIFICE, PARKER: 4 XHX7-S .031 ORIFICE	Carbon Steel
43	2	101-4585FPL	PLATE, SUPPORT, OUTLET COUPLING	Steel, 44W					
44	1	08-1753	MANIFOLD, LINE MOUNT, KCM	N/A					
45	1	08-1752	CARTRIDGE, PRESSURE REDUCING VALVE, PRJRLAN	N/A					
46	1	101-6229	ASSEMBLY, SHIFTING FORK	N/A					
47	1	101-5781	PLATE, TAG, SHIFTER	STAINLESS STEEL					
48	1	101-5588	TAG, RETURN	STAINLESS STEEL					
49	1	101-5589	TAG, INLET	TAG, SUPPLY					
50	2	02-E0199	CLAMP, PIPE, 2"	Steel, 44W					
51	2	02-E0186	CLAMP, PIPE, 1"	N/A					
52	1	02-E0187	CLAMP, PIPE, 1 1/4"	N/A					
53	2	1037-A4-144	ASSEMBLY, CYLINDER, DOOR	N/A					
54	1	101-6397	WELDMENT, SAFETY SWITCH	N/A					
55	2	101-6402	BUSHING, DOOR SLEEVE	STEEL TB DOM					
56	2	101-6403	SLEEVE, DOOR SWITCH	STEEL, 44W					
57	1	101-6400	ASSEMBLY, DOOR SWITCH	N/A					
58	4	101-6401	TUBE, BUSHING, SLEEVE	STEEL TB DOM					
59	1	101-6411	WELDMENT, BASE, SWITCH	N/A					
60	1	101-6406	ASSEMBLY, DOOR SWITCH	N/A					

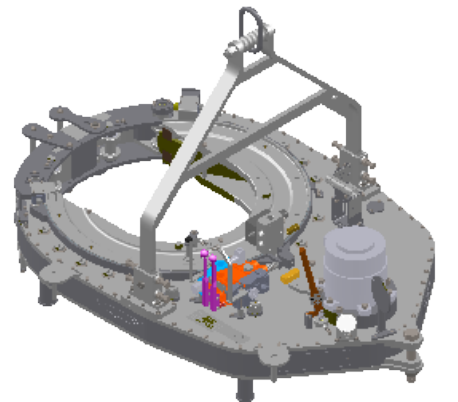

DESCRIPTION ASSEMBLY, TONG, 26000-60K, CC		
SIZE B	PART NO. 80-1903-3	REV C
MATERIAL		SHEET 2 OF 2