

TONG SPECIFICATION		
MAX TORQUE (FT-LBS/N·M)	60,000	81,360
ARM LENGTH (INCH/CM)	55.0	139.7
MASS (LBS/KG)	3,900	1,771
TORQUE (FT-LBS/N·M, ESTIMATED)		
AT PRESSURE (PSI/BAR):	2,000	138
Hi/Full	9,167	12,430
Lo/Full	60,000	81,360
SPEED (RPM, ESTIMATED)		
AT FLOW RATE (GPM/LPM):	60	227
Hi/Full	27.7	
Lo/Full	4.2	

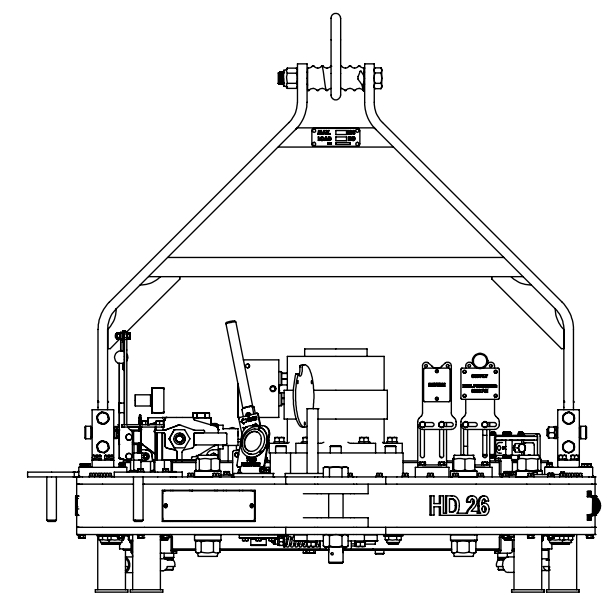
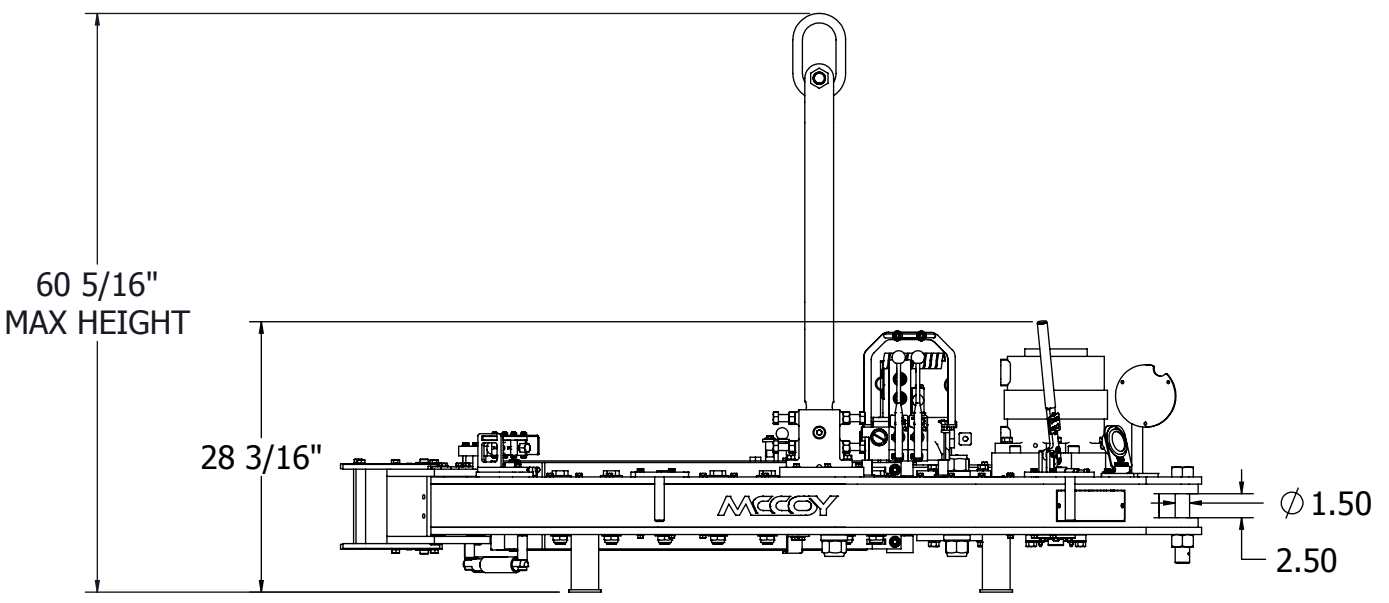

REVISIONS				
REV.	ECO NUMBER	ECO DESCRIPTION	ECO COMPLETED BY	ECO COMPLETED DATE
9	ECN002382	REPLACED SHOULDER BOLT WITH 02-1016 (X2)	SP	02/02/2015
A	ECN-002553	101-1694 WAS 101-1530, 101-2865 WAS 101-6122, ADDED 1483-500-00-07 & 101-8614	T.YIMER	22/JAN/2016
B	ECN16-0225	REPLACED 101-0022(X2) WITH 101-4585FPL(X2), 02-9222-ORING(X1) & 02-9222-PLUG(X1) WITH 02-9222(X1)	S. PANCHAL	11/07/2016
C	ECN16-0243	REMOVED 02-0120 (X1), ADDED 02-9228(X1), 02-9022(X1) & 02-E0564(X1)	S. PANCHAL	3/27/2017
X	N/A	REMOVE TABLE	R. RAHMAN	01/12/2018

UNLESS OTHERWISE SPECIFIED:			PROPRIETARY STATEMENT		
1. DIMENSIONS ARE IN INCHES	THIS DOCUMENT IS THE PROPERTY OF MCCOY CORPORATION AND IS CONSIDERED CONFIDENTIAL. THIS INFORMATION MAY NOT BE USED, DISCLOSED, COPIED, OR REPRODUCED IN ANY FORM, WITHOUT THE EXPRESS WRITTEN CONSENT OF MCCOY CORPORATION.				
2. TOLERANCES:					
ANGULAR ± 1°					
FRACTIONAL ± 1/16					
TWO PLACE DECIMAL ± 0.02					
THREE PLACE DECIMAL ± 0.005					
3. IDENTIFY P/N & MAIL P.O. USING 1/8 TO 1/4 ETCHED LETTERS, DENOTED BY "X"					
4. REMOVE BURRS & SHARP EDGES WITH 1/64x45° MAX					
5. MACHINED FILET RADII SHALL BE 1/32					
6. FINAL SURFACE ROUGHNESS AVG. (Ra) SHALL BE ≤ 250 MICRONS					
7. DIMENSIONS IN TRIANGLES ARE CRITICAL DIMENSIONS: 100% INSPECTION REQUIRED					
8. A TRIANGLE DENOTES A REVISION					
9. INTERPRET DRAWING PER ASME Y14.5-2009					

DRAWN	SHP	08/02/2011	DESCRIPTION ASSEMBLY, TONG, 26000-60K
CHECKED	MRM	09/06/2011	
APPROVED	MRM	09/06/2011	
THIRD ANGLE PROJECTION			SIZE PART NO. B 80-1903-1
WEIGHT 3694.34 LBS.			MATERIAL *

RELEASED FOR PRODUCTION

ITEM	QTY	P/N	DESCRIPTION	ITEM	QTY	P/N	DESCRIPTION
1	1	80-1910	ASSEMBLY, TONG, HD26-60K	51	1	101-6400	ASSEMBLY, DOOR SWITCH
2	1	1482-11A-00M	WELDMENT, DOOR	52	1	101-6411	WELDMENT, BASE, SWITCH
3	1	1482-11B-00M	WELDMENT, DOOR	53	1	101-6406	ASSEMBLY, DOOR SWITCH
4	2	1482-11-03	ROLLER, SUPPORT	54	4	101-6401	TUBE, BUSHING, SLEEVE
5	4	02-0096	BEARING, BALL, 6206	55	2	1037-A4-144	ASSEMBLY, CYLINDER, DOOR
6	4	1482-11-06	TUBE, SPACER, DOOR ROLLER	56	1	02-E0204	WRAP, SPIRAL, OD 1.60" X ID 1.40"
7	2	1482-11-08	TUBE, SPACER, SUPPORT ROLLER	57	1	101-6860	WELDMENT, VALVE GUARD
8	2	1482-11-04	SHAFT, ROLLER, DOOR SUPPORT	58	1	101-6861	WELDMENT, VALVE GUARD
9	4	1482-11-05	PLATE, LOCK, PIN	59	2	09-1048	BOLT, HEX, 3/8-16, 1 1/4, GR 8, ZINC, FULLY THREADED
10	2	1482-11A-12	SPRING, COMPRESSION	60	39	09-1046	3/8"-16 UNC - 1"
11	1	101-1333	WELDMENT, LATCH	61	2	09-1009	BOLT, HEX, 1/4-20, 1 1/4, GR 8, ZINC, FULLY THREADED
12	1	101-1488	WELDMENT, LATCH	62	10	09-1553	3/8"-16 UNC - 1-1/2"
13	2	1482-11A-10	PLATE, LID, DOOR LOCK	63	6	09-1054	3/8"-16 UNC - 2"
14	1	101-1927	WELDMENT, HANDLE, DOOR	64	3	09-1184	1/2"-13 UNC - 4-1/2"
15	1	101-1926	WELDMENT, HANDLE, DOOR	65	1	HBOLT 0.3750-16x0.75x0.75-N	
16	2	1482-12-08	WASHER, SPACER	66	1	09-1108	BOLT, HEX, 7/16-14, 1 1/4, STEEL, GR 8, ZINC
17	2	02-0520	BUSHING, Ø.875 X Ø.625 X .5L	67	6	09-0081	BOLT, HEX, 5/8-11, 2 1/2, STEEL, GR 8, ZINC
18	1	1482-11A-07	PLATE, LATCH HANDLE	68	6	09-1168	BOLT, HEX, 1/2-13, 1 1/4, STEEL, GR 8, ZINC, FULLY THREADED
19	1	1482-11B-06	PLATE, HANDLE, DOOR	69	12	09-1007	1/4"-20 UNC - 1"
20	1	1037-42	SPACER, CLUTCH	70	2	09-5806	NUT, HEX, 3/8-16, STEEL, GR 8, ZINC
21	1	1426-7	PLATE, MOUNT, MOTOR	71	1	09-5840	NUT, HEX, 1 1/2-6, STEEL, GR 8, ZINC, DOUBLE CHAMFER
22	1	87-0158	MOTOR, RINEER, 125 SERIES, 113 CID, SPLINED SHAFT	72	1	09-5808	NUT, HEX, 3/8-16
23	1	02-0120	LINKAGE, SHIFTING	73	59	09-5106	WASHER, SPRING LOCK, REGULAR, 3/8, 17/25, 0.035-0.125, STEEL, GR 8, ZINC
24	1	02-0018	BALL, SHIFTING	74	10	09-5110	1/2"
25	1	997-0-64	SPRING, COMPRESSION	75	6	09-5114	5/8"
26	1	DVA35-M-S	ASSEMBLY, DVA35 VALVE	76	12	09-5102	WASHER, SPRING LOCK, REGULAR, 1/4, 31/64, 0.035-0.125, STEEL, GR 8, ZINC
27	3	101-1322	WELDMENT, POST, VALVE MOUNT	77	5	09-5006	WASHER, PLAIN, FLAT, WIDE, 3/8, 1, 0.035-0.125, STEEL, ZINC
28	1	08-9062	VALVE, HYDRAULIC NEEDLE	78	2	09-4999	WASHER, PLAIN, FLAT, WIDE, 5/8, 1 3/4, 0.125-0.25, STEEL, ZINC
29	1	101-0727	MANIFOLD, HYDRAULIC, SAFETY DOOR	79	2	02-1016	SCREW, SHOULDER, SOCKET HEAD, 5/8, 3 1/4, STEEL, GR 8, ZINC
30	1	02-0245	GAUGE, PRESSURE, FLANGE	80	5	09-2298	SCREW, SHCS, 3/4-10 x 3
31	2	101-0023	PLATE, SUPPORT, HYDRAULIC	81	3	HITCH PIN .0930 X 1.125	PIN, HITCH, 0.0930 DIA, 1.125 LG
32	1	1037-36	BOLT, CAGE PLATE	82	4	09-0049	BOLT, SHOULDER, SOCKET HEAD, 5/8-11, 3/4, ALLOY STEEL
33	1	1482-39	PIN, BACKING	83	3	0.3125-Clevis Pin	
34	1	1482-54	PLATE RETAINER, BACKING PIN	84	1	10-9068	FITTING, 1 1/4 MORB, 1/2 FORB, STRAIGHT
35	1	02-0017	KNOB	85	4	09-2052	HX-SHCS 0.375-16x1.75x1.75-NZ
36	1	10-0010R	CARTRIDGE, RELIEF	86	4	09-1058	BOLT, HEX, 3/8-16, 3, GR 8, ZINC, FULLY THREADED
37	2	08-1625	CARTRIDGE, PILOT TO OPEN CHECK, LKHCXDN	87	1	09-1058	BOLT, HEX, 3/8-16, 3, GR 8, ZINC, FULLY THREADED
38	2	101-3586	GUIDE, BRAKE BAND	88	1	1483-500-00-07	PLATE, PRESSURE GAUGE MOUNT BASE
39	1	101-3595	BOLT, HEAVY HEX, 1 1/2-6, 9, STEEL, GR8, DRILLED END	89	1	101-1694	BRACKET, MOUNTING, GAUGE
40	1	101-6229	ASSEMBLY, SHIFTING FORK	90	1	101-2865	WELDMENT, GAUGE MOUNT
41	1	101-5780	WELDMENT, LEVER, SHIFT	91	2	09-5106	MOUNT WELDMENT, TORQUE GAUGE, KT 8625 BJ
42	1	101-5781	PLATE, TAG, SHIFTER	92	2	09-1042	WASHER, SPRING LOCK, REGULAR, 3/8, 17/25, 0.035-0.125, STEEL, GR 8, ZINC
43	1	101-5588	TAG, RETURN	93	1	02-9222	BOLT, HEX, 3/8-16, 1/2, GR 8, ZINC, FULLY THREADED
44	1	101-5589	TAG, INLET	94	2	101-4585FPL	PLUG, COUNTERSUNK, 1" ORB MALE
45	2	02-E0199	CLAMP, PIPE, 2"	95	1	02-9022	PLATE, SUPPORT, OUTLET COUPLING
46	2	02-E0186	CLAMP, PIPE, 1	96	1	02-9228	CHECK VALVE, 1/4 NPT
47	1	02-E0187	CLAMP, PIPE, 1 1/4	97	1	02-E0564	VALVE, CHECK, 1/2" NPT
48	1	101-6397	WELDMENT, SAFETY SWITCH				FITTING, 1/4, 1/32 ORIFICE, PARKER: 4 XHX7-S .031 ORIFICE
49	2	101-6402	BUSHING, DOOR SLEEVE				
50	2	101-6403	SLEEVE, DOOR SWITCH				

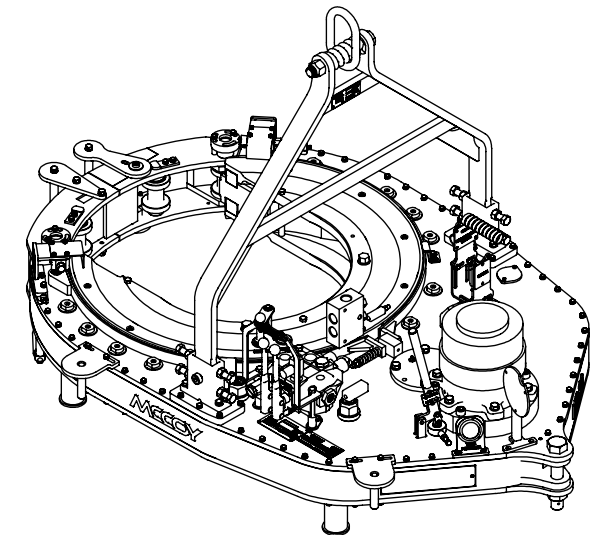

DESCRIPTION		
ASSEMBLY, TONG, 26000-60K		
SIZE	PART NO.	REV
B	80-1903-1	C
MATERIAL		SHEET 2 OF 2
*		