

TONG SPECIFICATION		
MAX TORQUE (FT · LBS/N · M)	75,000	101,700
ARM LENGTH (INCH/CM)	45.2	114.8
MASS (LBS/KG)	3,300	1,498
TORQUE (FT · LBS/N · M, ESTIMATED)		
AT PRESSURE (PSI/BAR):	2,450	169
Hi/Full	13,863	18,798
Lo/Full	75,000	101,700
SPEED (RPM, ESTIMATED)		
AT FLOW RATE (GPM/LPM):	60	227
Hi/Full	23.8	
Lo/Full	4.4	

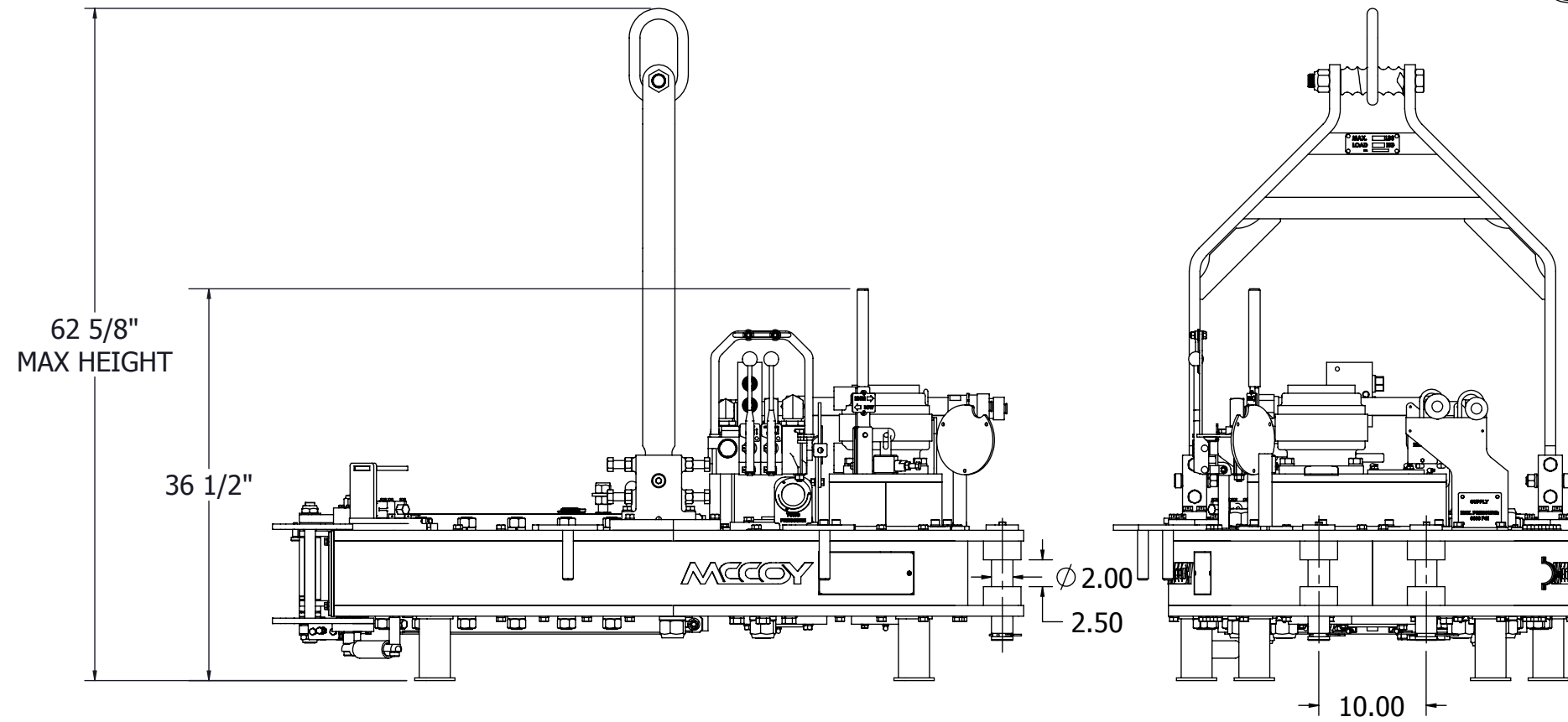

REVISIONS				
REV.	ECO NUMBER	ECO DESCRIPTION	ECO COMPLETED BY	ECO COMPLETED DATE
A	002550	REPLACED 101-5977 WITH 101-8625;REPLACED 101-6068 WITH 101-8635;REPLACED 101-5991 WITH 101-8634 (X2)	S. YUAN	03/21/2016
B	ECN-002613	REPLACED 10-0010R(X1) WITH 10-0084(X1), 101-1621(X1) WITH 101-5007(X1), 101-6075(X1) WITH 101-2865(X1) ADDED 1483-500-00-07(X1) & 02-9022(X1)	S. PANCHAL	06/03/2016
-	N/A	REMOVED TABLE	R. HENRY	1/19/2018

UNLESS OTHERWISE SPECIFIED:		PROPRIETARY STATEMENT			
1. DIMENSIONS ARE IN INCHES 2. TOLERANCES: ANGULAR ± 1° FRACTIONAL ± 1/16 TWO PLACE DECIMAL ± 0.02 THREE PLACE DECIMAL ± 0.005 3. IDENTIFY P/N & MAIL P.O. USING 1/8 TO 1/4 ETCHED LETTERS, DENOTED BY "X" 4. REMOVE BURRS & SHARP EDGES WITH 1/64x45° MAX 5. MACHINED FILET RADI SHALL BE 1/32 6. FINAL SURFACE ROUGHNESS A (Ra) SHALL BE ≤ 250 MICRONS 7. SHALL BE ≤ 250 MICRONS 8. A TRIANGLE DENOTES A REVISION 9. INTERPRET DRAWING PER ASME Y14.5-2009		THIS DOCUMENT IS THE PROPERTY OF MCCOY CORPORATION AND IS CONSIDERED CONFIDENTIAL. THIS INFORMATION MAY NOT BE USED, DISCLOSED, COPIED, OR REPRODUCED IN ANY FORM, WITHOUT THE EXPRESS WRITTEN CONSENT OF MCCOY CORPORATION.		DESCRIPTION ASSEMBLY, TONG, 14375-75K, NO BU	
DRAWN	MRM	CHECKED		SIZE	REV
APPROVED	BM	4/3/2013		B	B
THIRD ANGLE PROJECTION		WEIGHT		MATERIAL	
		3101.01 LBS.		N/A	

RELEASED FOR PRODUCTION

ITEM	QTY	P/N	DESCRIPTION	MATERIAL	ITEM	QTY	P/N	DESCRIPTION	MATERIAL
1	1	80-1000-2	ASSEMBLY, BASE TONG, 14-75K	N/A	49	2	02-E0199	CLAMP, PIPE, 2"	Steel, 44W
2	1	1037-A4-144	ASSEMBLY, CYLINDER, DOOR	N/A	50	1	101-5086	TAG, "MAKE"	STAINLESS STEEL
3	1	101-5971	ASSEMBLY, SWITCH, DOOR	N/A	51	1	101-5087	TAG, "BREAK"	STAINLESS STEEL
4	1	101-5974	WELDMENT, MOUNTING, SWITCH	N/A	52	1	101-6076	TAG, SHIFTER	STAINLESS STEEL
5	1	101-8625	ASSEMBLY, DOOR, 14-75K	N/A	53	1	02-0245	GAUGE, PRESSURE, FLANGE	N/A
6	1	101-5996	TUBE, SPACER	STEEL TB DOM	54	6	09-1048	BOLT, HEX, 3/8-16, 1 1/4, GR 8, ZINC, FULLY THREADED	
7	1	87-0130	MOTOR, RINEER, 37 SERIES, 26 CID, KEYED	N/A	55	3	09-1184	1/2"-13 UNC - 4-1/2"	
8	1	101-5951	GEAR, PINION, MOTOR	STEEL, 8620	56	1	09-1007	1/4"-20 UNC - 1"	*
9	2	101-1442	WELDMENT, MOUNT, VALVE	N/A	57	6	09-1046	3/8"-16 UNC - 1"	
10	2	101-1138	WELDMENT, COUPLING, INLET	N/A	58	4	09-1292	SCREW, HEX, 3/4-10, 1 3/4, STEEL, GR 8, ZINC	
11	1	101-1583	PLATE, SUPPORT, COUPLING	STEEL, 44W	59	2	09-1174	BOLT, HEX, 1/2-13, 2, STEEL, GR 8, ZINC, FULLY THREADED	
12	1	101-0022	PLATE, COUPLING, OUTLET	STEEL, 44W	60	4	09-1286	BOLT, HEX, 3/4-10, 1, STEEL, GR 8, ZINC, FULLY THREADED	
13	1	DVA35-M-S	ASSEMBLY, DVA35 VALVE	N/A	61	2	09-1608	BOLT, HEX, 7/16-20, 1 1/4, STEEL, GR 8, ZINC, FULLY THREADED	
14	1	101-1806	WELDMENT, MOUNT, PIPE	N/A	62	31	09-1172	BOLT, HEX, 1/2-13, 1 3/4, STEEL, GR 8, ZINC, FULLY THREADED	
15	1	101-2075	U-BOLT	STEEL	63	4	09-5106	WASHER, SPRING LOCK, REGULAR, 3/8, 17/25, 0.035-0.125, STEEL, GR 8, ZINC	
16	1	101-2076	U-BOLT	STEEL	64	4	09-5006	WASHER, PLAIN, FLAT, WIDE, 3/8, 1, 0.035-0.125, STEEL, ZINC	
17	1	101-1749	LEVER WELDMENT, MANUAL SHIFT	N/A	65	10	09-5806	NUT, HEX, 3/8-16, STEEL, GR 8, ZINC	
18	4	997-D8-160A	WELDMENT, LEG	N/A	66	1	09-9124	NUT, HEX, 1/2-13, STEEL, GR 8, ZINC	
19	1	101-3596	KEYSTOCK, GEAR	STEEL, 4140 HTSR	67	2	09-5908	NUT, HEX, 7/16-20 UNF	
20	1	10-9068	FITTING, 1 1/4 MORB, 1/2 FORB, STRAIGHT	N/A	68	38	09-5110	WASHER, SPRING LOCK, REGULAR, 1/2, 43/50, 0.125-0.25, STEEL, GR 8, ZINC	N/A
21	2	101-1497	TUBE, DETENT, SHIFTER	STEEL, 1020 CR	69	10	09-5106	WASHER, SPRING LOCK, REGULAR, 3/8, 17/25, 0.035-0.125, STEEL, GR 8, ZINC	N/A
22	2	997-0-64	SPRING, COMPRESSION	STEEL WIRE, ASTM 229	70	8	09-5118	WASHER, SPRING LOCK, REGULAR, 3/4, 1 17/64, 0.125-0.25, STEEL, GR 8, ZINC	N/A
23	2	02-0018	BALL, SHIFTING	N/A	71	1	09-5119	Washer, Type A, Flat, Narrow, Preferred, 1/2, 1 5/8, 0.035-0.125, STEEL, ZINC	
24	2	101-6943	ASSEMBLY, ANCHOR PIN	N/A	72	4	09-5725	NUT, NYLOCK, 1-8 NC	Steel, 44W
25	1	10-0084	CARTRIDGE, RELIEF VALVE, 2001-2500 PSI	N/A	73	1	02-1016	SCREW, SHOULDER, SOCKET HEAD, 5/8, 3 1/4, STEEL, GR 8, ZINC	
26	1	02-9206	FITTING, 1 MORB, 1 FNPT, ELBOW	N/A	74	2	02-E0249	SCREW, DRILLED SOCKET HEAD, 3/8-16 X 1 LG	
27	1	02-9215	FITTING, QUICK DISCONNECT, MALE 1 1/4	BRASS	75	4	09-2172	1/2"-13 UNC - 1-3/4"	
28	1	02-9212	FITTING, DUST CAP, 1 1/4	Plain Carbon Steel	76	1	02-0020	PIN, CLEVIS, 5/16 x 1	
29	1	02-9213	FITTING, DUST CAP, 1	N/A	77	1	101-6861	WELDMENT, VALVE GUARD	N/A
30	1	02-9214	FITTING, QUICK DISCONNECT, MALE 1	BRASS	78	1	101-6860	WELDMENT, VALVE GUARD	N/A
31	1	08-0114	FITTING, 3/4 FNPT, 3/4 FNPT, ELBOW	STEEL, MILD	79	1	02-9022	CHECK VALVE, 1/4 NPTF	N/A
32	1	08-0172	FITTING, 1 FNPT, 1 FNPT, ELBOW	Steel, Mild	80	1	1483-500-00-07	BRACKET, MOUNTING, GAUGE	Stainless Steel, 316
33	1	101-1750	FITTING, NIPPLE	STEEL	81	1	101-2865	MOUNT WELDMENT, TORQUE GAUGE, KT 8625 BJ	*
34	1	101-1618	FITTING, 1 MNPT, 1 MNPT, 18, STRAIGHT	STEEL	82	1	101-5007	WELDMENT, POST, TORQUE GAUGE	N/A
35	2	101-1619	FITTING, NIPPLE	STEEL					
36	1	02-9202	FITTING, 1 1/4 MORB, 1 1/4 FNPT, ELBOW	N/A					
37	1	08-9062	VALVE, HYDRAULIC NEEDLE	N/A					
38	1	02-9228	VALVE, CHECK, 1/2" NPT	N/A					
39	2	08-1625	CARTRIDGE, PILOT TO OPEN CHECK, LKHCXDN	N/A					
40	1	101-0727	MANIFOLD, HYDRAULIC, DOOR SWITCH	DURABAR					
41	2	02-0981	PIN, HITCH 0.148 X 2.938	N/A					
42	2	101-8634	BUSHING, LATCH SHAFT	STEEL TB DOM					
43	1	101-8635	SHAFT, DOOR LATCH	STEEL, 4140 HTSR					
44	1	101-5976	SHAFT, SUPPORT, ROTARY	STEEL, 4140 HTSR					
45	1	101-5588	TAG, RETURN	STAINLESS STEEL					
46	1	101-5589	TAG, INLET	TAG, SUPPLY					
47	2	02-E0186	CLAMP, PIPE, 1	N/A					
48	1	02-E0187	CLAMP, PIPE, 1 1/4	N/A					

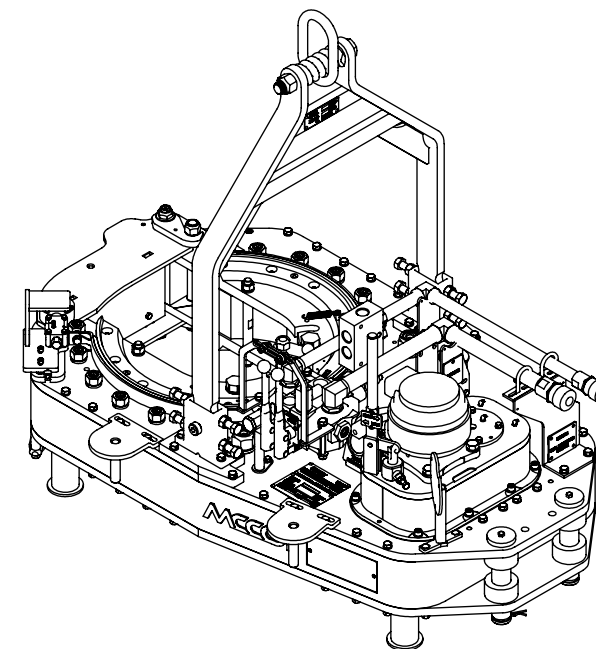

DESCRIPTION ASSEMBLY, TONG, 14375-75K, NO BU		
SIZE B	PART NO. 80-1001-10	REV B
MATERIAL N/A		SHEET 2 OF 2