

TONG SPECIFICATION		
MAX TORQUE (FT·LBS/N·M)	18,700	25,357
ARM LENGTH (INCH/CM)	35.7	90.7
MASS (LBS/KG)	1,150	522
TORQUE (FT·LBS/N·M, ESTIMATED)		
AT PRESSURE (PSI/BAR):	2,250	155
Hi/Full	3,740	5,071
Lo/Full	18,700	25,357
SPEED (RPM, ESTIMATED)		
AT FLOW RATE (GPM/LPM):	60	227
Hi/Full	77.0	
Lo/Full	15.4	

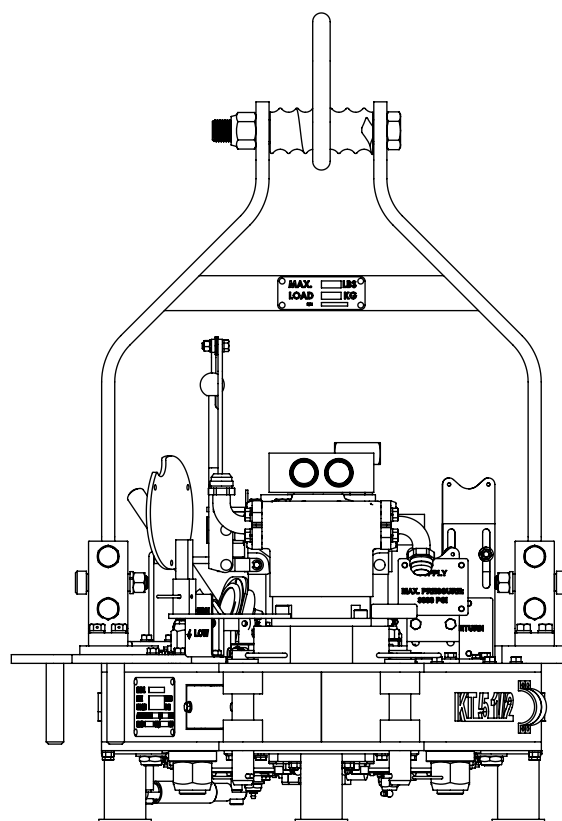
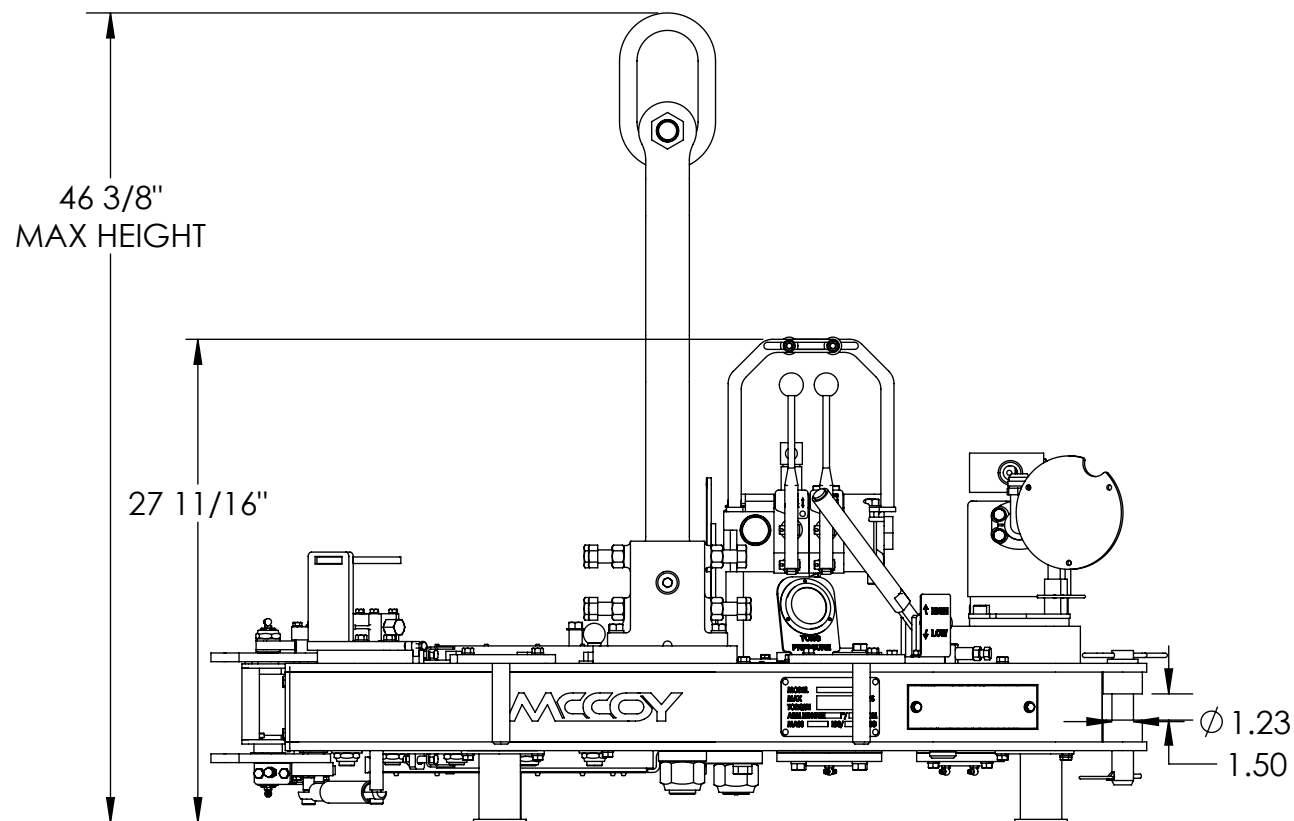

SYSTEM MAX TORQUE CAPACITY (FT LB)		
PIPE DIAMETER (IN)	STEEL DIES	GRITFACE DIES
5.500	18.7K	
DOWN TO 4.500	13K	13K
DOWN TO 4.000	11K	11K
DOWN TO 3.375	8K	
DOWN TO 3.000	6.5K	
DOWN TO 2.875	5.5K	
DOWN TO 2.375	4K	

ECN	REV.	DESCRIPTION	DATE	APPROVED
002272	1	REMOVED 1064-11(X1), 101-0150(X1), 101-0151(X1), 101-6157(X4), 101-6080(X4) & CE-HANDLE-2 AND ADDED 101-6860(X1) & 101-6861(X1)	09/APR/2014	SP
002591	A	1500-09-03A(x1) & 1483-500-00-07(x1) WERE 101-6122	12/APR/2016	R. RAJIUR
002609	B	REMOVED 10-0010R(X1), 87-0110(X1), 997-A10-149(X1), 01-0317(X1), 09-0106(X2), 09-9155(X2), 09-5832(X2) ADDED 10-0084(X1), 101-8942(X1), 10-9001(X1), 02-9022(X1), 02-0225(X2)	03/05/2016	SP

- UNLESS OTHERWISE SPECIFIED:
- DIMENSIONS ARE IN INCHES
 - TOLERANCES:
 - ANGULAR ± 1°
 - FRACTIONAL ± 1/16
 - TWO PLACE DECIMAL ± 0.02
 - THREE PLACE DECIMAL ± 0.005
 - IDENTIFY P/N & MAIL P.O. USING 1/8 TO 1/4 ETCHED LETTERS, DENOTED BY "X"
 - REMOVE BURRS & SHARP EDGES WITH 1/64x45° MAX
 - MACHINED FILET RADI SHALL BE 1/32
 - FINAL SURFACE ROUGHNESS AVG. (Ra) SHALL BE ≤ 250 MICRONS
 - DENOTES CRITICAL DIMENSION; 100% INSPECTION REQUIRED
 - A TRIANGLE DENOTES A REVISION
 - INTERPRET DRAWING PER ASME Y14.5-2009

PROPRIETARY STATEMENT

THIS DOCUMENT IS THE PROPERTY OF MCCOY CORPORATION AND IS CONSIDERED CONFIDENTIAL. THIS INFORMATION MAY NOT BE USED, DISCLOSED, COPIED, OR REPRODUCED IN ANY FORM, WITHOUT THE EXPRESS WRITTEN CONSENT OF MCCOY CORPORATION.

DRAWN	R. RAHMAN	04/12/2016
CHECKED	M. GERWING	04/12/2016
APPROVED	M. GERWING	04/12/2016

THIRD ANGLE PROJECTION

MCCOY GLOBAL

DESCRIPTION		REV B
ASSEMBLY, TONG, 5500-18K7		
SIZE	PART NO.	REV B
B	80-0420-23	
MATERIAL	SHEET 1 OF 2	
WEIGHT	1092.95 LBS.	

RELEASED FOR PRODUCTION