

SPECIFICATIONS:

1. GENERAL:
 - 1.1 LCD DISPLAY: 5" DIAGONAL
 - 1.2 15 BUTTON NUMERIC KEYPAD
 - 1.3 4 BUTTON HOT KEYS
 - 1.4 POWER, ALARM AND WARNING LED
2. FEATURES:
 - 2.1 DESIGNED FOR MOBILE PRESSURE TESTING IN HARSH ENVIRONMENTS
 - 2.2 DATA AND ALARM LOGGING
3. CONNECTIONS:
 - 3.1 POWER: 115VAC
 - 3.2 QUAD SENSOR
4. CONSTRUCTION:
 - 4.1 HOUSING MATERIAL: PELICAN CASE 1400
 - 4.2 HARDWARE: STAINLESS STEEL
 - 4.3 LENS: 1/4" THICK POLYCARBONATE (LEXAN)
5. ENVIRONMENTAL:
 - 5.1 OPERATING TEMPERATURE: -40°C TO +85°C
 - 5.2 STORAGE TEMPERATURE: -40°C TO +85°C
 - 5.3 SEALING: NEMA 4X, IP67
6. ALL INTERCONNECT CABLES ARE PROVIDED.

REVISIONS				
ZONE	REV	DESCRIPTION	DATE	APPROVED
	A	Initial Release	12/04/15	R.C.

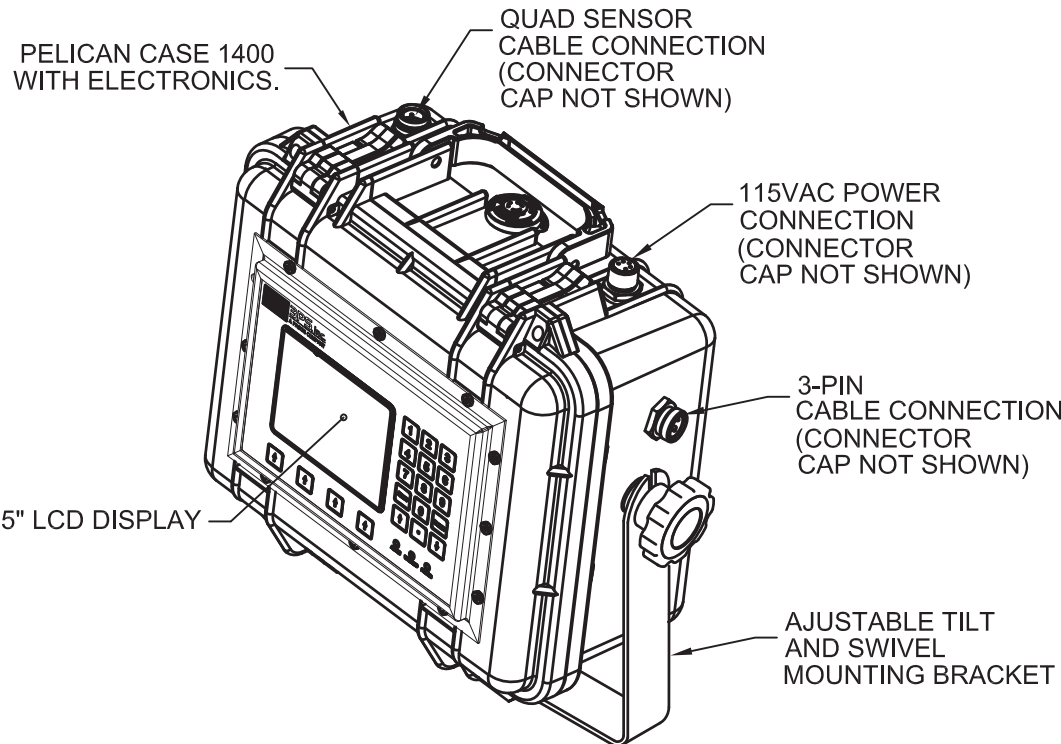
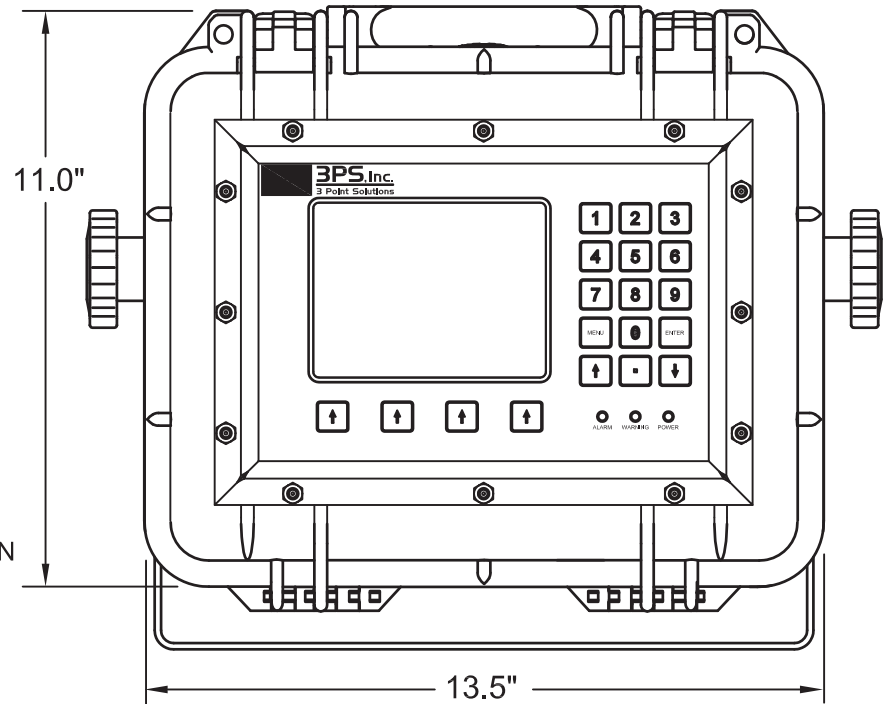
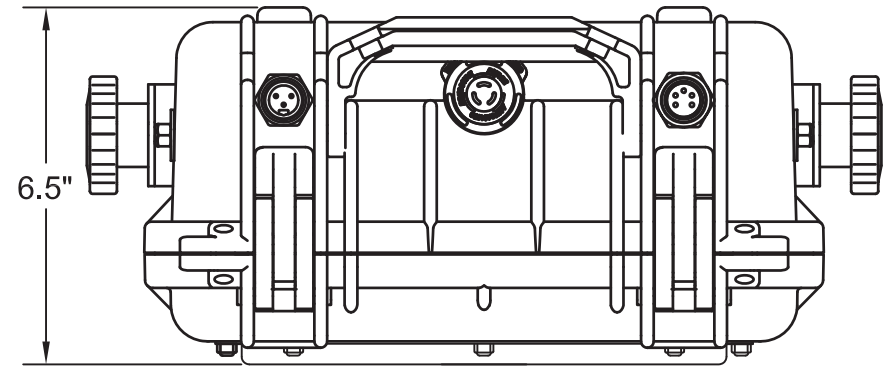

©2015 BY 3PS, INC. THIS DOCUMENT MAY NOT BE COPIED OR REPRODUCED IN ANY WAY WITHOUT THE WRITTEN CONSENT OF 3PS, INC. 3PS, INC. OWNS ALL RIGHTS TO THIS WORK AND INTENDS TO ENFORCE ITS RIGHTS UNDER THE COPYRIGHT LAWS AS A PUBLISHED WORK.		UNLESS OTHERWISE SPECIFIED DIMENSIONS ARE IN INCHES TOLERANCES ARE: FRACTIONS ± 1/32 DECIMALS .XX ± .01 ANGLES ± .5° .XXX ± .005					
APPROVALS		DATE		SPECIFICATION CONTROL DRAWING, PORTABLE SD50LT			
DRAWN DP	12/04/15	MATERIAL N/A	SIZE C			DWG NO. SD50LT-PDA12111-001-0	REV A
CHECK RC	12/04/15	FINISH N/A	SCALE -			FSCM NO. 1MHK2	SHEET 1 of 1
RELEASE MA	12/04/15						