

PU2500E24-10 SPECIFICATIONS			
POWER REQUIREMENT	3 PHASE 480 V 60 Hz	3 PHASE 380 V 50 Hz	3 PHASE 240 V 50 Hz
FULL LOAD / INRUSH CURRENT	82.4 A / 319 A	97.6 A / 403 A	165A / 638 A
MAXIMUM OPERATING PRESSURE	3000 PSI / 207 BAR		
MAXIMUM HYDRAULIC FLOW	60 GPM / 227 LPM		
HYDRAULIC RESERVOIR CAPACITY	130 GALLON / 492 L		
OIL REQUIREMENT	AW-68		
SPECIAL FEATURES	COOLER		
	HEATER		
	TECH CABLE		
	EXPLOSION PROOF		

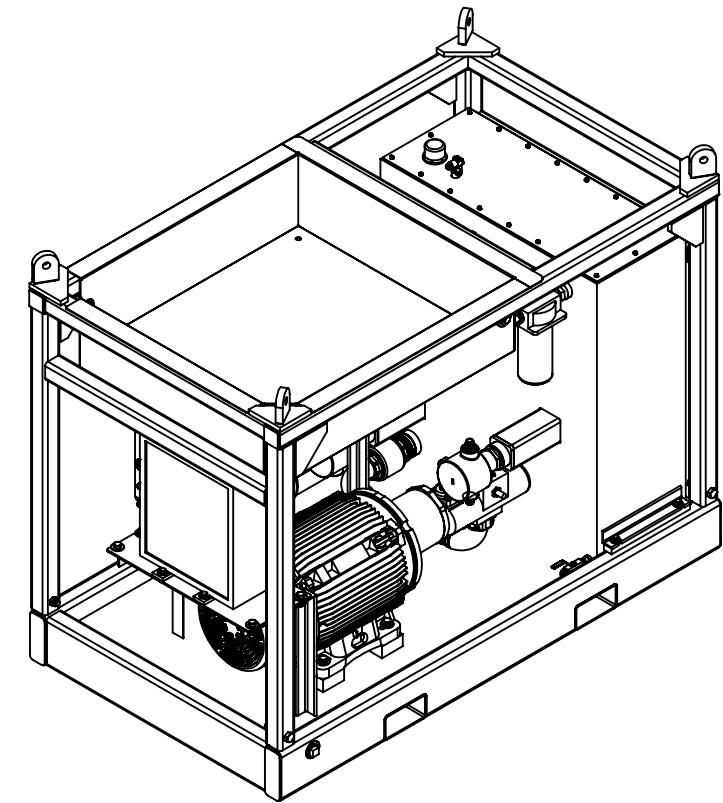
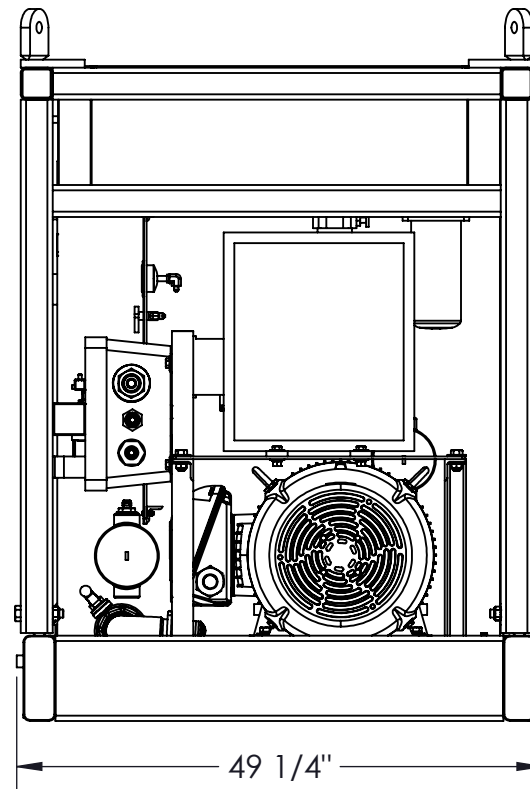
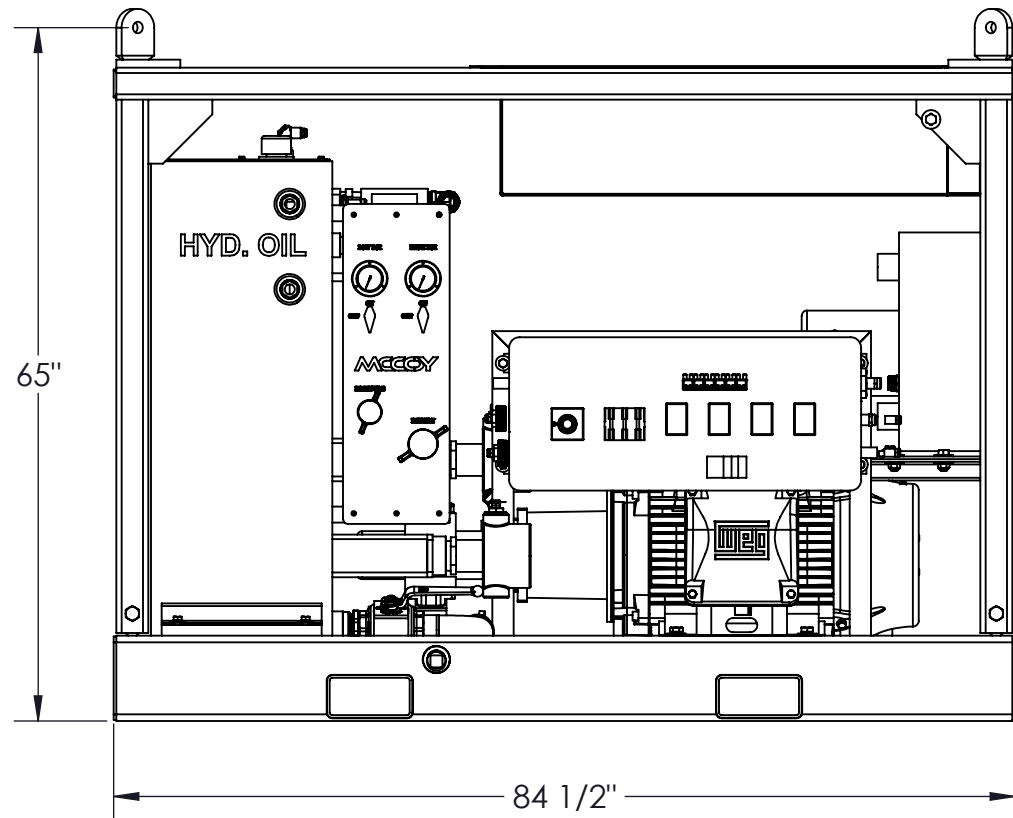

REVISIONS

REVISION	ECO NUMBER	ECO DESCRIPTION	ECO COMPLETED BY	ECO COMPLETED DATE
A	N/A	INITIAL RELEASE	N/A	N/A
B	17-0101	ADD GA SPECIFICATION SHEET	M.BUDDEN	5/5/2017

UNLESS OTHERWISE SPECIFIED:			PROPRIETARY STATEMENT		DESCRIPTION	
1. DIMENSIONS ARE IN INCHES	THIS DOCUMENT IS THE PROPERTY OF MCCOY CORPORATION AND IS CONSIDERED CONFIDENTIAL. THIS INFORMATION MAY NOT BE USED, DISCLOSED, COPIED, OR REPRODUCED IN ANY FORM, WITHOUT THE EXPRESS WRITTEN CONSENT OF MCCOY CORPORATION.		MCCOY GLOBAL		ASSEMBLY, POWER UNIT, ELECTRIC, WITH COOLER & HEATER	
2. TOLERANCES: ANGULAR ± 1° FRACTIONAL ± 1/16 TWO PLACE DECIMAL ± 0.02 THREE PLACE DECIMAL ± 0.005	DRAWN		R.CENAC	07/31/2014	SIZE	PART NO.
3. IDENTIFY P/N & MAIL P.O. USING 1/8 TO 1/4 ETCHED LETTERS, DENOTED BY "X"	CHECKED		J.KELLY		B	PU2500E24-10
4. REMOVE BURRS & SHARP EDGES WITH 1/64x45° MAX	APPROVED		J.KELLY		MATERIAL	REV B
5. MACHINED FILET RADII SHALL BE 1/32	THIRD ANGLE PROJECTION		WEIGHT		N/A	
6. FINAL SURFACE ROUGHNESS AVG. (Ra) SHALL BE ≤ 250 MICROINCHES	WEIGHT		4618 LBS.			
7. CIRCLES DENOTES CRITICAL DIMENSION: 100% INSPECTION REQUIRED	MATERIAL		N/A			
8. A TRIANGLE DENOTES A REVISION						
9. INTERPRET DRAWING PER ASME Y14.5-2009						

RELEASED FOR PRODUCTION

ITEM	QTY	P/N	DESCRIPTION	ITEM	QTY	P/N	DESCRIPTION
1	1	DSKD-03	WELDMNT, SKID, POWER UNIT, ELECTRIC	44.19	7	RX-38	CABLE GLAND, 1/2 NPT
2	1	HRES-150-01	ASSEMBLY, RESERVOIS, HYDRAULIC	44.20	1	RX-40	CABLE, MARINE, 75FT
3	1	DBSKT-08	HOSE BASKET FRAME, DIESEL POWER UNIT	44.21	1	RX-43	FUSE BLOCK, BUSEMAN, 30A 600V 3P
4	1	DBSKT-008S1	BASKET, POWER UNIT	44.22	1	RX-45	NIPPLE, CLOSE, 1/2
5	1	PU2500-H21-01	HEAT EXCHANGER, ELECTRIC MOTOR, EXPLOSION PROOF	44.23	1	RX-44	FITTING, 1/2IN, CAPPED ELBOW
6	1	PU2500-H12	WELDMNT, BULKHEAD	44.24	1	RX-46	CABLE, MARINE, 18 1/2
7	1	7042HL-005-S5B-FL3	PLATE, PANEL, BULKHEAD	44.25	1	RX-52	BUSHING, 2 X 1 1/2
8	1	GNSH20-20	GEAR PUMP, DOUBLE, HI/LOW VALVE	44.26	1	RTBC-EP	POWER CONNECTION BOX, THERMOSTAT
9	1	PU2500-H16	ADAPTER, MOTOR/PUMP, BELL HOUSING	44.27	1	RX-59	BUSHING, REDUCER, 1 MNPT X 1/2 FNPT, APP RB100-50
10	1	PU2500-H14	MOTOR SHAFT COUPLING 2 3/8" B X 5/8" KEY	44.28	3	RX-60	BUSHING, REDUCER, 1 1/2 X 1/2, APP RB150-50
11	1	PU2500-H18	SHAFT COUPLING, PUMP, 14T, 12/24 SPLINE, MfgNo: M500A1412C	44.29	2	RX-61	BUSHING, REDUCER, 2 X 1/2, APP RB200-50
12	1	PU2500-H17	SPIDER, COUPLING, MOTOR	44.30	2	RX-62	BUSHING, REDUCER, 2 MNPT X 1 1/2 FNPT, APP RB200-150
13	1	DPU660-S1	BLOCK, FILTER	44.31	1	PU2500-H11-02	STARTER, SPOT 13063-2-CE3KB
14	1	2070	VALVE, RELIEF	44.32	1	RX-63	CABLE, 14-4C TYPE P, 28FT, GENP 279310
15	2	BAC-3M25RCFF	GAUGE, 2 1/2, 3K, 1/4 MNPT	44.33	1	RX-64	CABLE, TYPE P, 2-4C, 10FT, GENP 302610
16	1	W43-16-24U	FITTING, 1 1/2IN CODE 61 X 1IN FNPT, STRAIGHT	44.34	1	RX-65	CABLE, 14-7C TYPE P, 10FT, GENP 281170
17	1	PU2500-H19	SUCTION STRAINER, SCHROEDER, 2 1/2"	44.35	2	RX-66	CABLE GLAND, #424AN10, 1/2 NPT
18	1	KITFIT-EPU	KIT, FITTING, HYDRAULIC	45	1	KITFIT-PU2500E24	FITTING KIT-PU2500E24
18.1	1	1871	BELL RED GV, 1 1/4 X 1/2	45.1	2	1612-G	FITTING, PLUG, 1 1/2 NPT
18.2	1	1875	FITTING, REDUCER, 1/2 MNPT, 1/4 FNPT	45.2	1	1670	FITTING, QUICK DISCONNECT, PLUG, DUST, FEMALE, 1 1/4
18.3	1	1872	FITTING, NIPPLE, 1/2, CLOSE, GALV.	45.3	1	20F6X	FITTING, SWIVEL, 1 1/4 MNPT, 1 1/4 FJIC
18.4	1	1873	FITTING, NIPPLE, 1 1/4, CLOSE, GALVANIZED	45.4	2	1617	FITTING, 1 MNPT, 1 MJIC, ELBOW
18.5	1	1874	COUPLING, MERCHANT, 1/4	45.5	1	1469	FITTING, 1 MNPT, 1 MJIC, STRAIGHT
18.6	1	1876	FITTING, NIPPLE, BLK, 1/4 X 1/2	45.6	1	1494	FITTING, BUSHING, REDUCER, 3/4 MNPT X 3/8 FNPT
19	2	D40H-75-300-SL	CLAMP, T-BOLT 2 1/2	45.7	1	1527	FITTING, TEE, 3/8" MNPT X 3/8" MJIC X 3/8" MJIC
20	1	H40-24	HOSE, 2 1/2 X 24	45.8	2	1610	FITTING, 3/4 MNPT, PLUG
21	2	CM4556	VALVE, PARKER, 1/4 NPT	45.9	2	1576	FITTING, 1/4 MNPT, 1/4 MJIC, ELBOW
22	1	PN24-33T	PIPE NIPPLE, 1 1/2 MNPT X 33, SCH 80	45.10	3	4-6C5OX-S	FITTING, 3/8 MORB, 1/4 MJIC, ELBOW
23	1	PN20-33T	PIPE NIPPLE, 1 1/4 X 33 MNPT, SCH 80	45.11	1	1499	FITTING, REDUCER BUSHING, 1 1/4 X 1 NPT
24	1	PN12-20T	FITTING, 3/4 MNPT X 20 LONG SCH. 80 PIPE NIPPLE	45.12	1	1669	FITTING, TEE, BRANCH, 1 MNPT, 1 FNPT
25	1	HYDOIL	LETTER, CLEAR, ADHESIVE	45.13	2	1470	FITTING, 1 1/4, MNPT, 1 1/4, MJIC, STRAIGHT
26	1	1014	U-BOLT, 1/4-20, 1 3/4 ID	45.14	1	1611	FITTING, 1 MNPT, PLUG
27	7	SST-18	SCREW, BUTTON HEAD, 1/4-20 X 1, STAINLESS	45.15	1	1463	NIPPLE, HEX, 1 1/4
28	7	1737	NUT, NYLOCK, 1/4-20 SS	45.16	1	1462	FITTING, NIPPLE, HEX, 1"
29	4	1151	LOCKWASHER, 5/8, STEEL, GR8	45.17	2	CM4556	VALVE, PARKER, 1/4 NPT
30	4	203	SCREW, HEX, 5/8-11, 2 3/4, STEEL, GR 8, ZINC	45.18	1	1461	FITTING, 3/4 MNPT, 3/4 MNPT, HEX NIPPLE
31	20	195A	WASHER, FLAT, 5/8, GR8	45.19	2	1653	FITTING, 1/4 FNPT, 1/4 MJIC, ELBOW
32	8	1103	LOCKWASHER, 1/2	45.20	2	1576-A	FITTING, 1/4 MNPT, 3/8 MJIC, ELBOW
33	12	1112	SCREW, HEX, 1/2-13, 1 1/2	45.21	1	16VTX-S	FITTING, 1 MNPT, 1 MJIC, 45
34	20	1102	WASHER, FLAT, 1/2, STEEL, GR08	45.22	1	V500P-12	VALVE, BALL, BRASS, 3/4" NPT, PARKER# V500P-12
35	4	1101	NUT, HEX HEAD, 1/2-13	45.23	1	PN40-C	PIPE NIPPLE, 2 1/2 X CLOSE, SCH. 80
36	8	1156-A	NUT, NYLOCK, 5/8 - 11	45.24	1	1391	FITTING, STREET ELBOW, LOW PRESSURE, 3/4
37	6	1157	SCREW, HEX, 5/8-11 X 1 1/2, GR8	45.25	1	1393	FITTING, STREET ELBOW, LOW PRESSURE, 1 1/4 IN
38	4	1087	NUT, NYLOCK, 1/2-13	45.26	1	1504	FITTING, PIPE NIPPLE, HEX, 1 1/2"
39	1	KITHOSE-PU2500E24	KIT, FITTING, HYDRAULIC	45.27	1	1562	FITTING, 1/4 MNPT, 1/4 MJIC, STRAIGHT
40	2	287320	HEATER, 480V/380V, 3 PHASE	45.28	1	1666	FITTING, QUICK DISCONNECT, PLUG, DUST, FEMALE, 1
41	1	PU2500-H23	TECH CABLE, 50FT	45.29	1	1445	FITTING, QUICK DISCONNECT, WING TYPE 1 1/4 FEMALE
42	1	KITHYD-DPU	ASSEMBLY, HYDRAULIC FITTINGS	45.30	1	1440	FITTING, QUICK DISCONNECT, 1 FML-WING TYPE
42.1	1	SNS-25N-25S-11	ADAPTER, WELD, 2 1/2	45.31	1	20-24CTXS	FITTING, ELBOW, 90 DEG., 1 1/2" MNPT X 1 1/4" MJIC
42.2	1	BVAL-2500S-4321	VALVE, BALL, 2 1/2" SAE	45.32	1	24CD	FITTING, ELBOW, 1 1/2 NPT, STREET EL
42.3	1	40SFO	FLANGE, SPLIT, 2 1/2", CODE 61	46	1	PU4060-S33	SWITCH, FLOAT, 1/4 MNPT
42.4	1	BSE-25HB-25S-11	ADAPTER, 2 1/2, 2 1/2, 90	47	1	20-24CTXS	FITTING, ELBOW, 90 DEG., 1 1/2" MNPT X 1 1/4" MJIC
42.5	1	SBE-25HB-25SM-11	FITTING, 2 1/2 HOSE BARB X 2 1/2, CODE 61 FLANGE ADAPTER, 90 DEG				
43	2	1160	SCREW, HEX, 5/8-11, 2, STEEL, GR8				
44	1	KITMOTOR-PU2500-01	POWER UNIT, ELECTRIC, COOLER				
44.1	1	PU2500-H9-01	ELECTRIC MOTOR-75 HP, EX 480VAC, 3PH, 50 / 60HZ, C-FACE W/FEET, 1800 RPM, NOT F-2 MOD NOT F2 MODIFIED				
44.2	1	PU2500-H11-01	MOTOR STARTER, 75 HP, EX 480VAC, 3PH, 50/60 HZ EXPLOSION PROOF				
44.3	1	1499	FITTING, REDUCER BUSHING, 1 1/4 X 1 NPT				
44.4	1	RX-19	WEG F2 MODIFY FOR 75 HP				
44.5	1	RX-25	CABLE, CLX, CRF, 2/3				
44.6	2	RX-26	CORD GRIP, 1IN				
44.7	1	RX-27	CABLE, CLX, 14/3				
44.8	2	RX-28	CONNECTION, TMCX, 1/2 IN				
44.9	6	RX-8	CONNECTOR, INSULATED				
44.10	3	RX-29	FUSE, 600V, ATQ AMP Q1				
44.11	1	RX-30	CONTRACTOR, 127V, 9A				
44.12	1	RX-31	RELAY, OVERLOAD, 2.5A 600V				
44.13	1	RX-32	BUSHING, REDUCER, 2 1/2 X 1 1/4				
44.14	2	RX-34	PLUG, RECESSED, 2IN				
44.15	1	RX-35	BUSHING, REDUCER, 3 X 1 1/4				
44.16	1	RX-36	BUSHING, REDUCER, 2 X 1				
44.17	1	RX-39	UNILET, APPLENTION				
44.18	2	RX-37	FITTING, CABLE GLAND, 3/4 NPT				

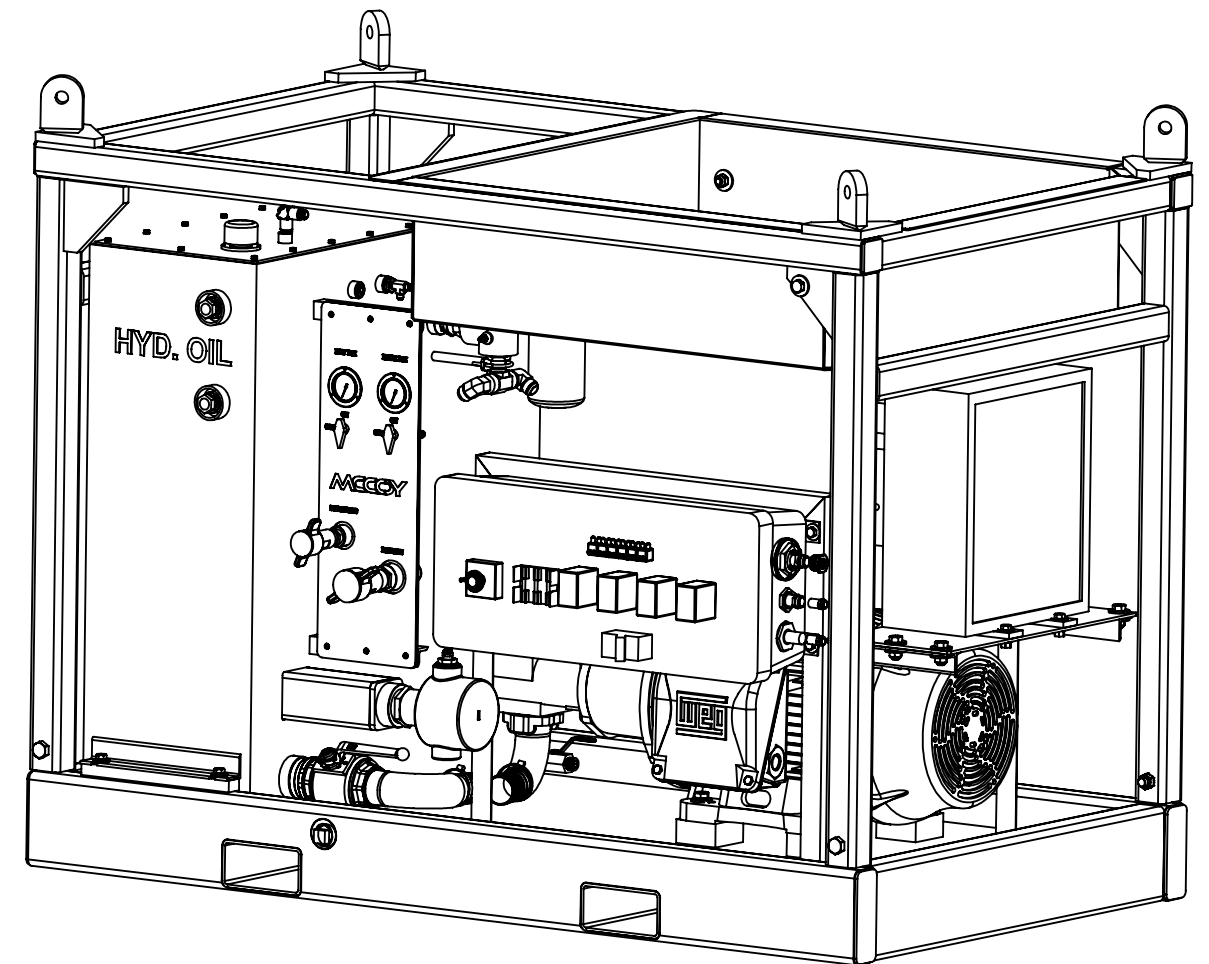

DESCRIPTION			
ASSEMBLY, POWER UNIT, ELECTRIC, WITH COOLER & HEATER			
SIZE	PART NO.	REV	
B	PU2500E24-10	B	
MATERIAL		SHEET 2 OF 7	
N/A			

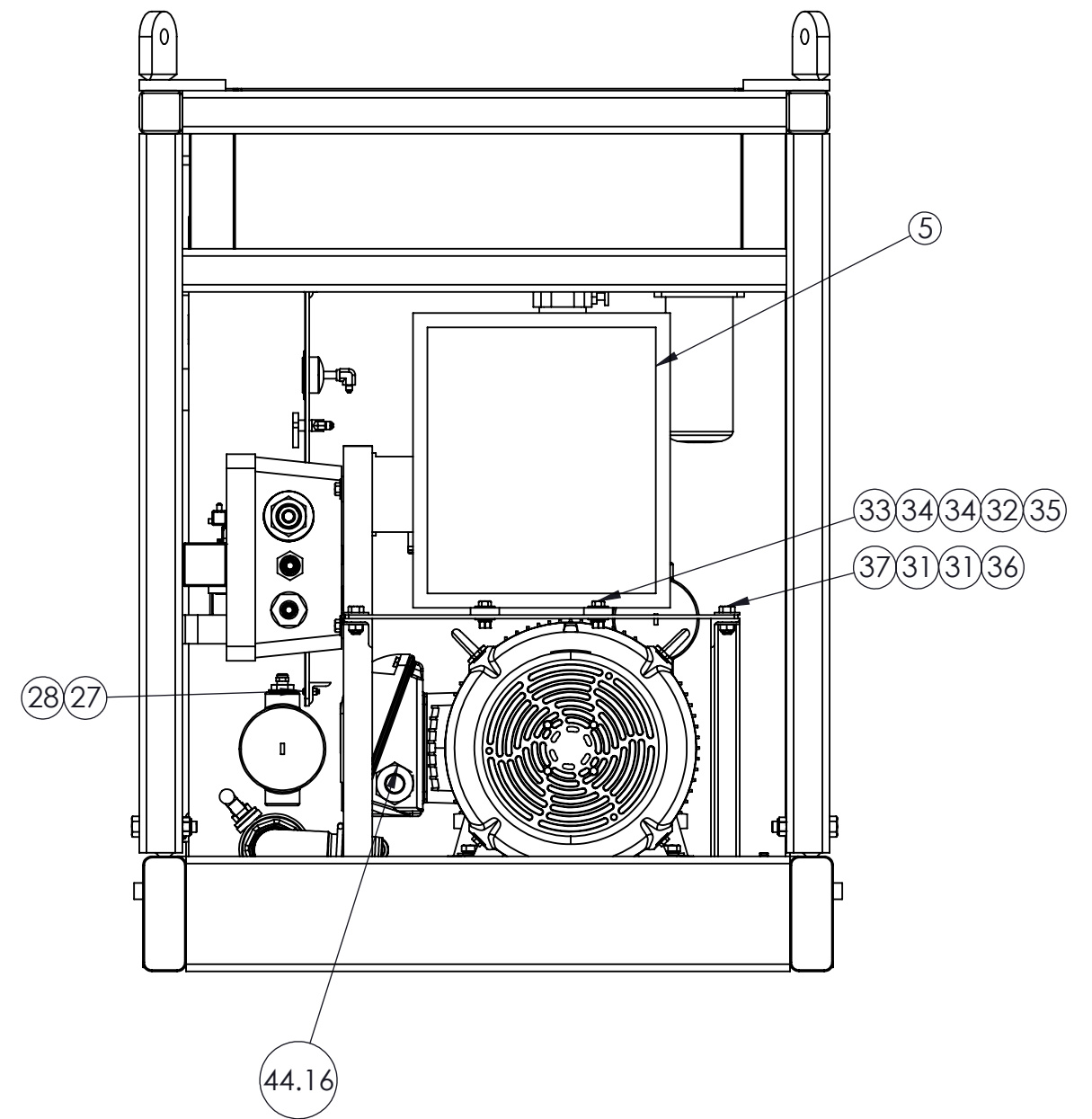
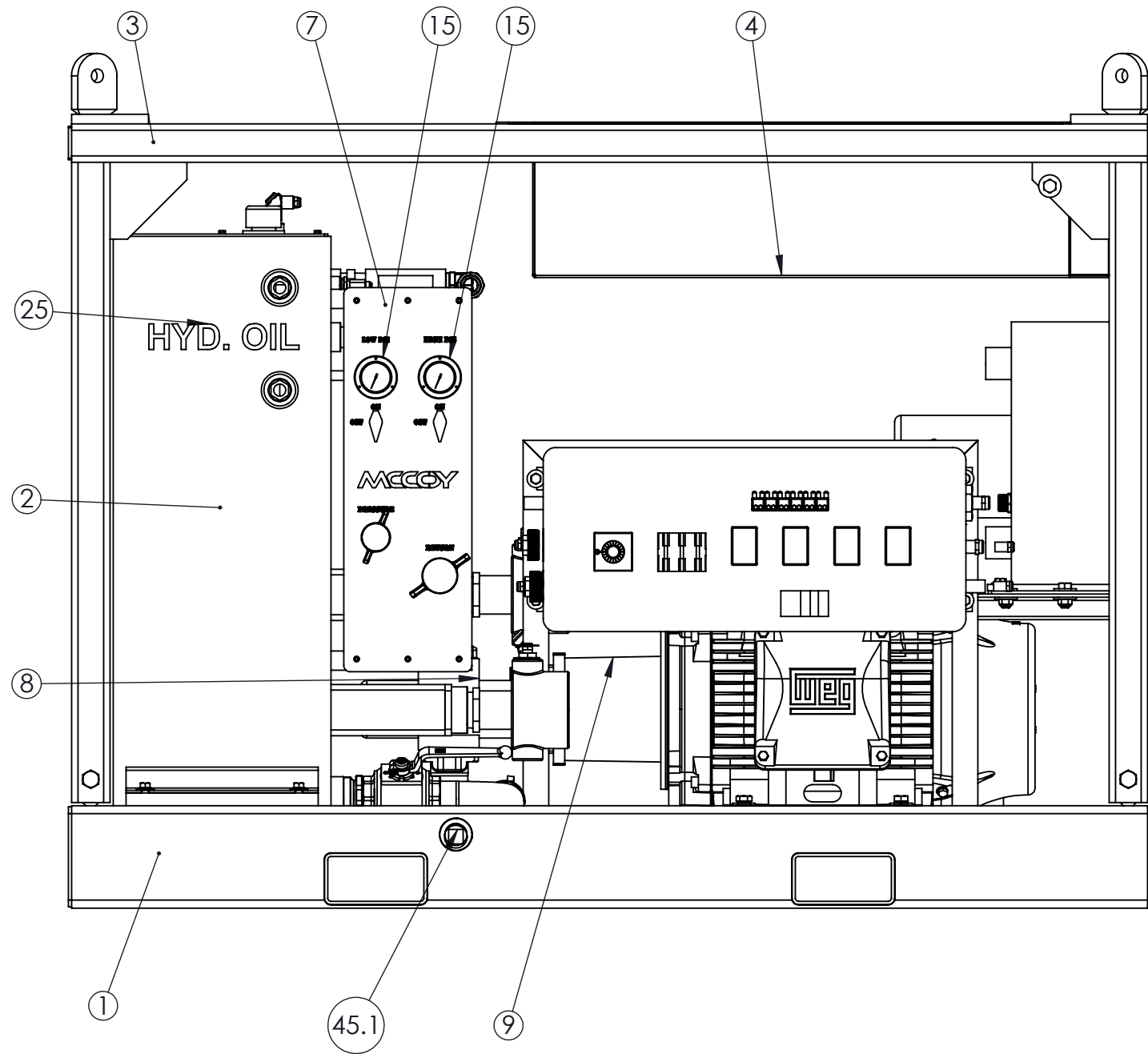

DESCRIPTION			
ASSEMBLY, POWER UNIT, ELECTRIC, WITH COOLER & HEATER			
SIZE	PART NO.	REV	
B	PU2500E24-10	B	
MATERIAL	N/A	SHEET 3 OF 7	

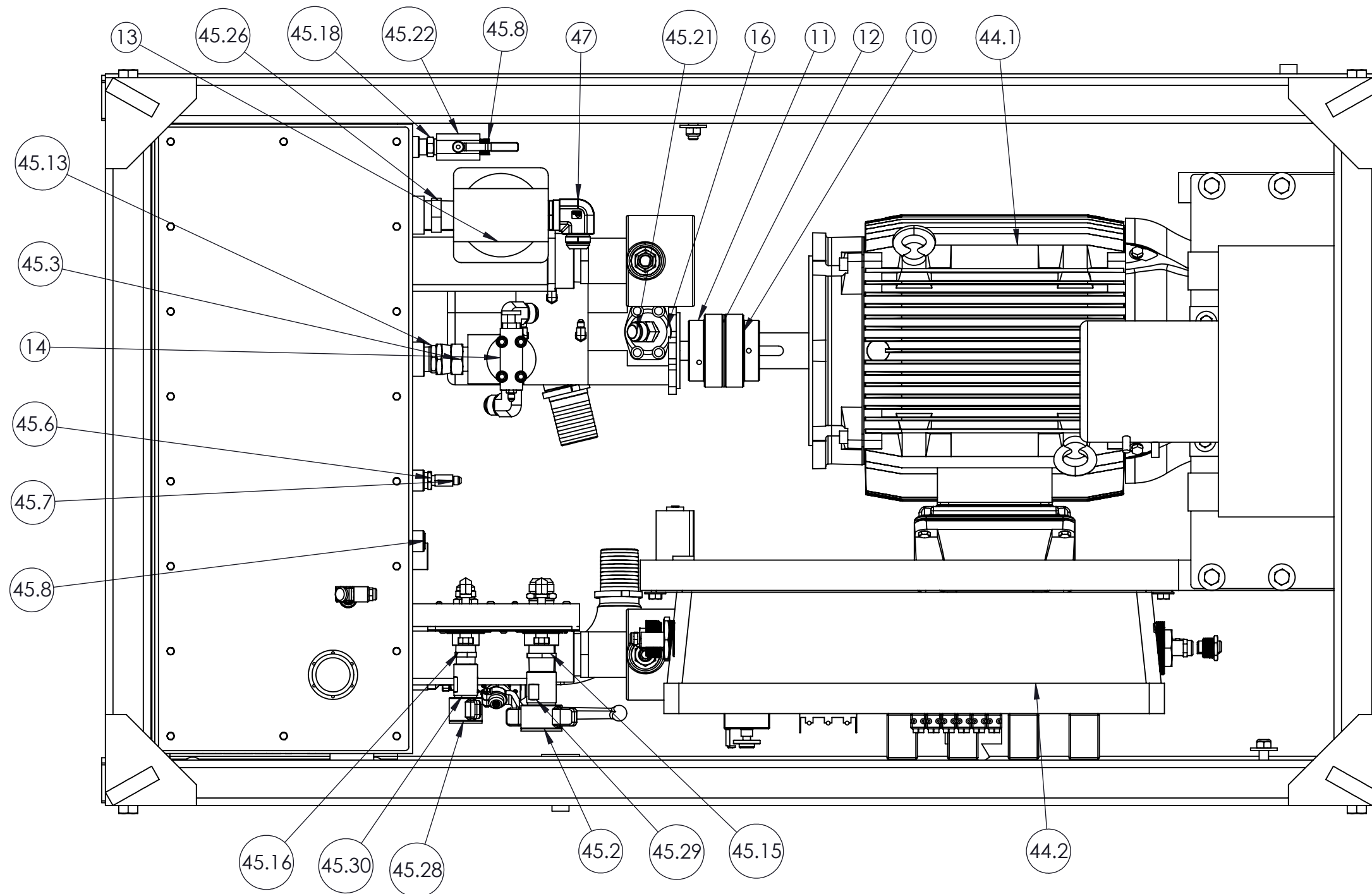

DESCRIPTION			
ASSEMBLY, POWER UNIT, ELECTRIC, WITH COOLER & HEATER			
SIZE	PART NO.	REV	
B	PU2500E24-10	B	
MATERIAL		SHEET 4 OF 7	
		N/A	

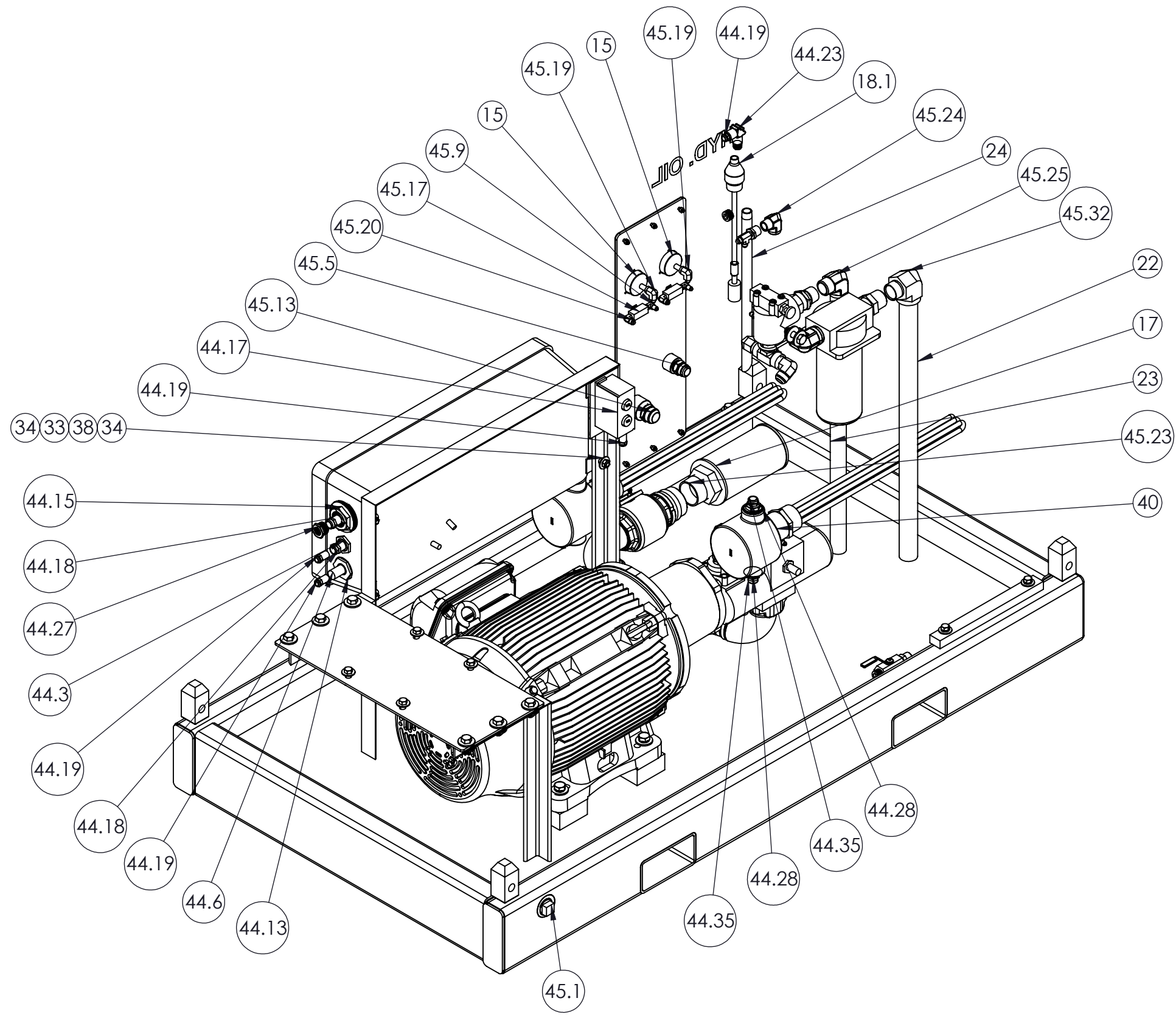

DESCRIPTION	 ASSEMBLY, POWER UNIT, ELECTRIC, WITH COOLER & HEATER	
SIZE	PART NO.	REV
B	PU2500E24-10	B
MATERIAL	N/A	SHEET 5 OF 7

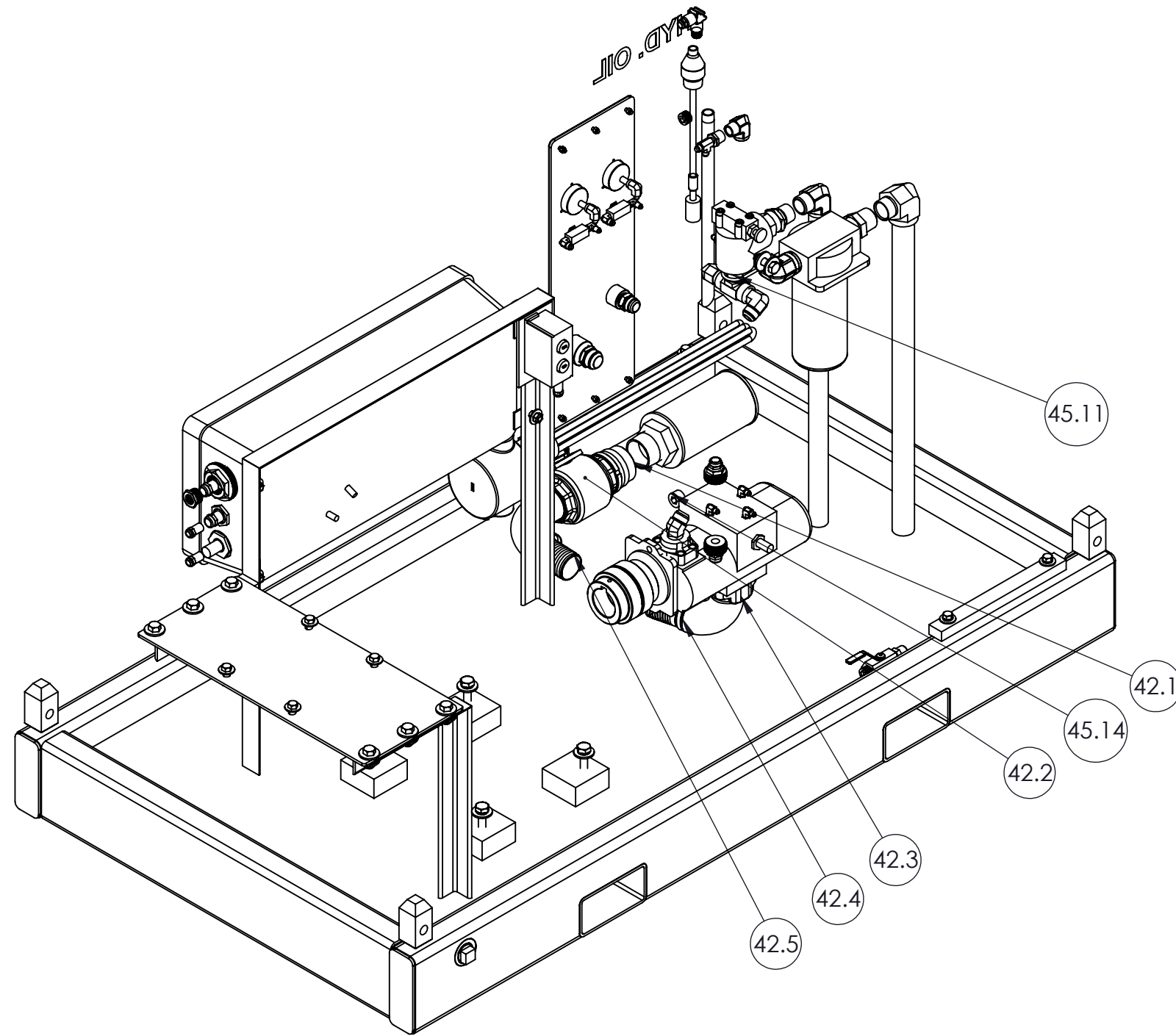

DESCRIPTION			
ASSEMBLY, POWER UNIT, ELECTRIC, WITH COOLER & HEATER			
SIZE	PART NO.	REV	
B	PU2500E24-10	B	
MATERIAL		SHEET 6 OF 7	
N/A			

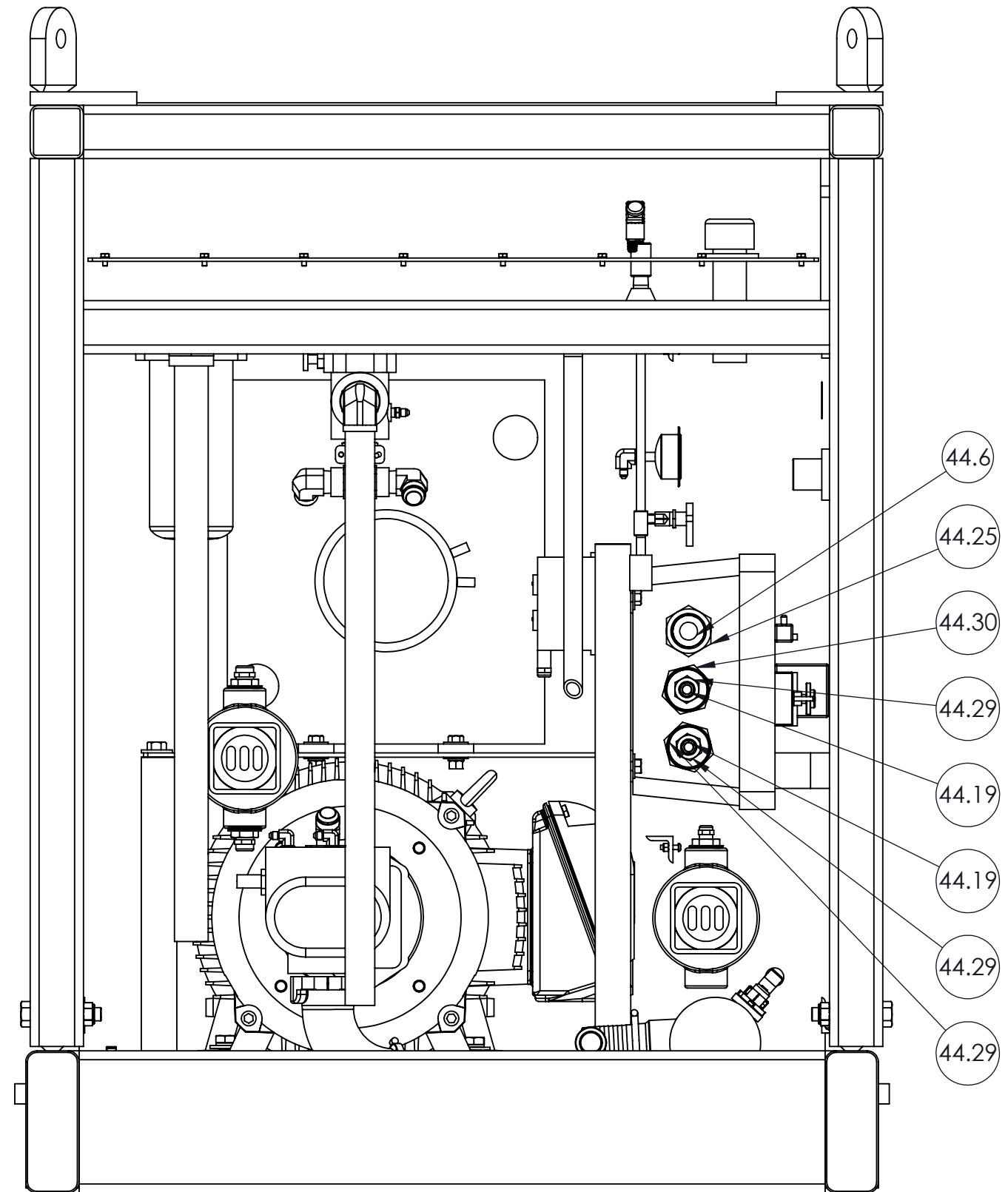

DESCRIPTION			
ASSEMBLY, POWER UNIT, ELECTRIC, WITH COOLER & HEATER			
SIZE	PART NO.		REV
B	PU2500E24-10		B
MATERIAL	N/A		SHEET 7 OF 7