

RP6012

12-1/4" (31.1 cm) 50,000 lbs-ft (67,790 Nm)

Continuously Rotating Bucking Unit

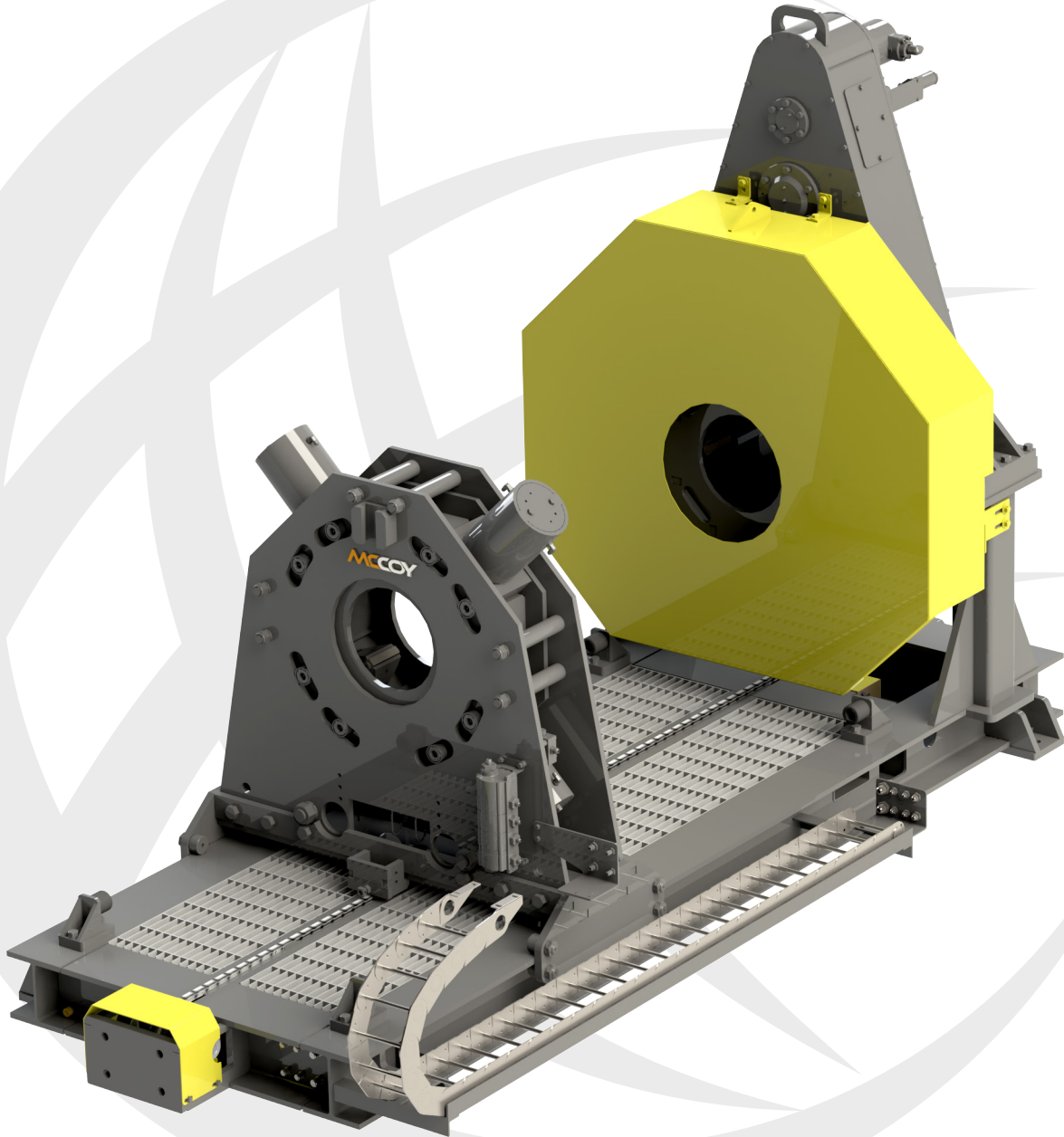

SPECIFICATIONS | OPERATION | MAINTENANCE | PARTS

MCCOYGLOBAL.COM



ORIGINAL INSTRUCTIONS

| THIS TECHNICAL DOCUMENT APPLIES TO THE FOLLOWING MODELS: | | |
|--|-----|------------------------------------|
| BUCKING UNIT MODEL | REV | DESCRIPTION |
| RP6012 | A | 12-1/4" 50K hydraulic bucking unit |

McCoy has made an effort ensure that all illustrations are accurate, but please note that some illustrations used in this manual may not exactly visually match your equipment.

PATENTED & PATENTS PENDING



**This page intentionally
left blank**

Copyright © 2008 - 2016 McCoy Global, including its wholly owned subsidiaries, (“McCoy”), all rights reserved. This document is the property of McCoy and is supplied as reference information for users of our products. This document and the contents within are considered confidential information, not to be disclosed, copied, transmitted, transcribed in any form, or stored on any type of data storage media without the express written consent of McCoy.

McCoy has made every effort to ensure the information contained in this document is accurate and current. This manual is intended to provide equipment operation and safety instructions for your equipment. However, McCoy does not warrant or guarantee that the information is either complete or accurate in every respect and the user of the manual should consult with its McCoy sales representative for any clarifications and updates.

The user of the manual shall protect, indemnify, and hold harmless McCoy and its directors, officers, employees, and agents from and against all liability for personal injury, death, or property damage resulting directly or indirectly from the use of the information contained in this manual.

Observance of all descriptions, information and instructions set out in this manual is the full responsibility of the user. This manual is intended for guidance and informational purposes and must be used in association with adequate training and on-the-job supervision to provide safe and effective equipment use.

It is the responsibility of the user to conform to all regulations and requirements issued by an authority or agency which may affect the operation, safety or equipment integrity, that may overrule the content of this documentation.

The user will acknowledge and obey any general legal or other mandatory regulation in force relating to accident prevention, safety, and equipment integrity.



**This page intentionally
left blank**

| Summary Of Revisions | |
|----------------------|-------------------------|
| Date | Description Of Revision |
| JAN 2016 | Initial release |

SECTION 1: INTRODUCTION

- 1.0 INTRODUCTION & CONTACT INFORMATION 1.3
- 1.1 SCOPE 1.4
- 1.2 GENERAL HEALTH AND SAFETY 1.5
 - 1.2.1 Hazard Labels 1.5
 - 1.2.2 General Safe Operation Guidelines 1.5
 - 1.2.3 Rigging and Overhead Lifting 1.6
 - 1.2.4 Maintenance Safety 1.6
 - 1.2.5 Replacement Parts 1.7
 - 1.2.6 Environmental Impact 1.7
- 1.3 ACRONYMS AND TERMINOLOGY 1.8
 - 1.3.1 Acronyms and Definitions 1.8
 - 1.3.2 Terms and Definitions 1.9

SECTION 2: EQUIPMENT & LUBRICATION SPECIFICATIONS

- 2.0 EQUIPMENT DESCRIPTION 2.3
- 2.1 MAJOR COMPONENT IDENTIFICATION 2.6
- 2.2 EQUIPMENT SPECIFICATIONS 2.8
- 2.3 RECOMMENDED LUBRICANT SPECIFICATIONS 2.9
 - 2.3.1 Hydraulic Fluid 2.9
 - 2.3.2 Gear Fluid 2.9
 - 2.3.3 Grease 2.9

SECTION 3: INSTALLATION & COMMISSIONING

- 3.0 RECEIPT, INSPECTION, AND HANDLING OF EQUIPMENT 3.3
 - 3.0.1 Lifting with a Forklift 3.4
- 3.1 ANCHORING THE UNIT IN PLACE (OPTIONAL) 3.5
- 3.2 HYDRAULICS & ELECTRONICS 3.7
 - 3.2.1 Bucking Unit Hydraulic Schematic 3.7
 - 3.2.2 Main Hydraulic Connections 3.8
- 3.3 TONG / BACKUP JAW DIE AVAILABILITY & INSTALLATION 3.11
 - 3.3.1 Strip Die Availability 3.11
 - 3.3.2 Jaw/Jaw Die Installation & Removal 3.11
- 3.4 UNIT PLACEMENT & SETUP 3.12
 - 3.4.1 Operational Surface 3.12
 - 3.4.2 Component Placement 3.12
 - 3.4.3 Load Cell Configuration 3.13
 - 3.4.4 Adjusting Clamp & Torque Pressure 3.14
 - 3.4.5 Installing a Turns Encoder 3.15

SECTION 4: OPERATION

- 4.0 OPERATOR TRAINING 4.3
- 4.1 OPERATOR SAFETY 4.3
- 4.2 CONTROL PANEL OPERATION GUIDE 4.4
- 4.3 PRE-OPERATIONAL CHECKS 4.5
- 4.4 GENERAL OPERATIONAL COMMENTS 4.5
- 4.5 INITIAL STARTUP 4.6
- 4.6 PIPE INSTALLATION 4.6
- 4.7 MAKING AND BREAKING CONNECTIONS 4.7
- 4.8 EXTREME COLD WEATHER OPERATION CONSIDERATIONS 4.8

SECTION 5: MAINTENANCE

- 5.0 GENERAL MAINTENANCE SAFETY PRACTICES 5.3
- 5.1 CLEANING 5.3
- 5.2 PREVENTIVE MAINTENANCE PRACTICES 5.3
- 5.3 HYDRAULIC SYSTEM MAINTENANCE 5.4
- 5.4 HYDRAULIC SYSTEM DEPRESSURIZATION 5.4
- 5.5 LUBRICATION INSTRUCTIONS 5.5
 - 5.5.1 Tong Grease Diagram 5.6
 - 5.5.2 Backup Grease Diagram 5.7
 - 5.5.3 Skid Grease Diagram 5.8
- 5.6 RECOMMENDED PERIODIC INSPECTIONS 5.9
 - 5.6.1 Load Cell 5.9
 - 5.6.2 Hydraulic Hoses 5.9
 - 5.6.3 Clamp Cylinders 5.9
- 5.7 ASSEMBLY PRACTICES 5.11
- 5.8 DAILY INSPECTION & MAINTENANCE CHECKLIST 5.12

5.9 MONTHLY MAINTENANCE CHECKLIST..... 5.14

5.10 TUBULAR CONNECTION EQUIPMENT DECOMMISSIONING & SHIPPING..... 5.16

 5.10.1 Shipping Instructions..... 5.18

5.11 TUBULAR CONNECTION EQUIPMENT RECOMMISSIONING PROCEDURE..... 5.19

SECTION 6: TROUBLESHOOTING

6.0 TONG WILL NOT DEVELOP SUFFICIENT TORQUE 6.3

6.1 FAILURE OF JAWS TO GRIP PIPE 6.4

6.2 TONG RUNNING TOO SLOWLY..... 6.4

6.3 EQUIPMENT WILL NOT ENGAGE PIPE, OR DOES NOT PROVIDE ADEQUATE GRIP 6.5

6.4 GENERAL COMMENTS 6.5

SECTION 7: PARTS & ASSEMBLIES

Illustration 7.1: RP6012 Continuously Rotating Bucking Unit Assembly..... 7.3

Illustration 7.2: 200-6012-1 Tong Assembly 7.4

Illustration 7.3: 2026-6500-1 Swivel Assembly 7.5

Illustration 7.4: 2700-7000-01 Swivel Keeper Assembly..... 7.5

Illustration 7.5: 2000-7000-02 Swivel Support Assembly..... 7.6

Illustration 7.6: 250-6500-12 Tong Vise Assembly 7.7

Illustration 7.7: 291-6500 Tong Flow Divider Assembly 7.8

Illustration 7.8: 400-3000-1 Clamp Cylinder..... 7.9

Illustration 7.9: 200-6012 Tong Assembly 7.10

Illustration 7.10: 204-6012 Outer Manifold Assembly 7.11

Illustration 7.11: 206-6000-1 Pinion Sprocket Assembly..... 7.12

Illustration 7.12: 213-6000-1 Clutch Gear Assembly..... 7.13

Illustration 7.13: 220-6000-1 Shifter Assembly 7.14

Illustration 7.14: 235-6000-1 Drive Gear Assembly 7.15

Illustration 7.15: 239-6000-1 Shift Cylinder Mount Assembly 7.16

Illustration 7.16: 3000-6500-03 16.5in Rotating Head Guard Assembly..... 7.17

Illustration 7.17: 300-6500-12 12.75in Backup Assembly 7.18

Illustration 7.18: 330-6500 Delta Power 6 Port Flow Divider 7.19

Illustration 7.19: 350-6500-1 Carriage Assembly 7.20

Illustration 7.20: 372-6500-12 11.75 Backup Vise Assembly 7.21

Illustration 7.21: BUCS11825-05 Cam Follower Pin Assembly..... 7.22

Illustration 7.22: BUCS11825-02 Cam Follower Assembly..... 7.22

Illustration 7.23: 500-6012-12 12ft Skid Assembly..... 7.23

Illustration 7.24: 508-3000-1 Idler Sprocket Assembly..... 7.24

Illustration 7.25: 571-6500-1 Sprocket Cover Assembly..... 7.24

Illustration 7.26: 509-3000-1 Drive Sprocket Assembly 7.25

Illustration 7.27: 540-3000 Bumper Stop Assembly..... 7.26

SECTION 8: TORQUE/TURNS MANAGEMENT

8.0 TORQUE MEASUREMENT 8.3

8.1 PERIODIC LOAD CELL INSPECTION AND MAINTENANCE 8.3

 8.1.1 Inspection..... 8.3

SECTION 9: OEM DOCUMENTATION

9.0 OEM DOCUMENTATION LINKS 9.3

| | |
|---|------|
| Illustration 1.2.1: Equipment Handling Warnings | 1.6 |
| Illustration 2.0.1: RP6012 Bucking Unit | 2.3 |
| Illustration 2.0.2: RP6012 Dimensions & Hazard Areas | 2.5 |
| Illustration 2.1.1: RP6012 Component Identification | 2.6 |
| Illustration 2.1.2: RP6012 with Optional Accessories..... | 2.7 |
| Illustration 3.0.1: RP6012 Forklift Lifting Procedure..... | 3.4 |
| Illustration 3.2.1: Hydraulic Connection Cleaning / Maintenance | 3.8 |
| Illustration 3.2.2: Hydraulic Connection Cleaning / Maintenance | 3.8 |
| Illustration 3.2.2: Securing Hydraulic Connections | 3.9 |
| Illustration 3.3.1: Jaw Die Removal..... | 3.11 |
| Illustration 3.4.1: Operator Line of Sight & Equipment Placement | 3.12 |
| Illustration 3.4.2: Pin Style Load Cell Installation..... | 3.13 |
| Illustration 3.4.1: Clamp & Torque Pressure Adjustment | 3.14 |
| Illustration 3.4.2: Turns Encoder Installation | 3.15 |
| Illustration 4.2.1: Control Panel Functions & Readouts | 4.4 |
| Illustration 4.6.1: Level Pipe Installation..... | 4.7 |
| Illustration 5.5.1: Tong Grease Diagram | 5.6 |
| Illustration 5.5.2: Backup Grease Diagram | 5.7 |
| Illustration 5.5.3: Skid Grease Diagram | 5.8 |
| Illustration 7.1: RP6012 Continuously Rotating Bucking Unit Assembly..... | 7.3 |
| Illustration 7.2: 200-6012-1 Tong Assembly | 7.4 |
| Illustration 7.3: 2026-6500-1 Swivel Assembly | 7.5 |
| Illustration 7.4: 2700-7000-01 Swivel Keeper Assembly..... | 7.5 |
| Illustration 7.5: 2000-7000-02 Swivel Support Assembly..... | 7.6 |
| Illustration 7.6: 250-6500-12 Tong Vise Assembly | 7.7 |
| Illustration 7.7: 291-6500 Tong Flow Divider Assembly | 7.8 |
| Illustration 7.8: 400-3000-1 Clamp Cylinder..... | 7.9 |
| Illustration 7.9: 200-6012 Tong Assembly | 7.10 |
| Illustration 7.10: 204-6012 Outer Manifold Assembly | 7.11 |
| Illustration 7.11: 206-6000-1 Pinion Sprocket Assembly..... | 7.12 |
| Illustration 7.12: 213-6000-1 Clutch Gear Assembly..... | 7.13 |
| Illustration 7.13: 220-6000-1 Shifter Assembly | 7.14 |
| Illustration 7.14: 235-6000-1 Drive Gear Assembly | 7.15 |
| Illustration 7.15: 239-6000-1 Shift Cylinder Mount Assembly | 7.16 |
| Illustration 7.16: 3000-6500-03 16.5in Rotating Head Guard Assembly..... | 7.17 |
| Illustration 7.17: 300-6500-12 12.75in Backup Assembly | 7.18 |
| Illustration 7.18: 330-6500 Delta Power 6 Port Flow Divider | 7.19 |
| Illustration 7.19: 350-6500-1 Carriage Assembly | 7.20 |
| Illustration 7.20: 372-6500-12 11.75 Backup Vise Assembly | 7.21 |
| Illustration 7.21: BUCS11825-05 Cam Follower Pin Assembly..... | 7.22 |
| Illustration 7.22: BUCS11825-02 Cam Follower Assembly | 7.22 |
| Illustration 7.23: 500-6012-12 12ft Skid Assembly..... | 7.23 |
| Illustration 7.24: 508-3000-1 Idler Sprocket Assembly..... | 7.24 |
| Illustration 7.25: 571-6500-1 Sprocket Cover Assembly..... | 7.24 |
| Illustration 7.26: 509-3000-1 Drive Sprocket Assembly | 7.25 |
| Illustration 7.27: 540-3000 Bumper Stop Assembly..... | 7.26 |



**This page intentionally
left blank**



SECTION 1: INTRODUCTION



**This page intentionally
left blank**

1.0 INTRODUCTION & CONTACT INFORMATION

Congratulations, and thank you for purchasing quality tubular connection equipment from McCoy Global. This unit will provide years of outstanding performance. Proper maintenance and care will extend its life and ensure years of excellent performance and reliability. The installation and commissioning, operating, and maintenance instructions in this manual will assist you in giving your equipment the care it requires. Please read the manual before installing and using your equipment. Replacement parts are readily available from McCoy Global. Should you need replacement parts, or should you experience any difficulty not covered in this manual, please contact:

McCoy Global Canada

14755 121A Avenue
Edmonton, Alberta, Canada
T5L 2T2

Phone: 780.453.3277

Fax: 780.455.2432

McCoy Global USA - Tongs & Bucking Units

4225 HWY 90 East
Broussard, LA, USA
70518

Phone: 337.837.8847

Fax: 337.837.8839

McCoy Global USA - Service

6530 Petropark Drive
Houston, TX, USA
77041

Phone: 281.377.4264

Fax: 281.377.4278

McCoy Global UK Ltd.

Units 9/10 Ocean Trade Center
Minto Avenue, Altens Industrial Estate
Aberdeen, AB12 3JZ
United Kingdom

Phone: +44.1224.245140

Fax: +44.1224.890176

McCoy Global Singapore PTE Ltd.

49 Tuas View Loop
Singapore, 637701
Republic of Singapore

Phone: +44.1224.245140

Fax: +44.1224.890176

McCoy Global S.A.R.L

Warehouse No. FZS1BJ03
Jebel Ali Free Zone - South Zone
Dubai, United Arab Emirates

Phone: +971.4803.6900

Fax: +971.4803.6909

Email Sales: dcsales@mccoyglobal.com

www.mccoyglobal.com

Technical manuals are produced and published by McCoy Global Inc.. McCoy Global has made an effort ensure that all information in this document is accurate, but please note that some illustrations used in this manual may not visually match actual purchased equipment. If you believe information in this publication is missing or erroneous, please contact one of our Technical Publications Departments at McCoy Global Canada or McCoy Global USA Tongs & Bucking Units.

Standard Terms and Conditions of Sale (including warranty information):

<http://www.mccoyglobal.com/tcs.pdf>

1.1 SCOPE

This technical manual is the main document supplied by McCoy Global for the equipment identified on Page iii of the preamble. The intent of this document is to provide descriptions of the systems, installation, commissioning and operating instructions, maintenance guidelines, spare parts information, and technical drawings and schematics (where applicable).

The OEM-recommended installation, commissioning, operation, maintenance, and troubleshooting instructions are to be regarded as guidelines, and are not intended to be a comprehensive operating guide for user specific application. Due to the wide variety of operating conditions it remains the responsibility of each equipment owner to use these guidelines together with an experienced manager to develop safe operating procedures that conform to American Petroleum Institute (or equivalent) standards, applicable State/Province or local regulations, and any corporate regulations/operating practices.

1.2 GENERAL HEALTH AND SAFETY

AUTHORIZED USE ONLY!**READ THIS MANUAL BEFORE USING EQUIPMENT**

Only authorized, trained, and competent personnel shall operate, maintain, and repair this equipment.

Fully review this manual and comply with all safety and environmental protection instructions before operating equipment.

1.2.1 Hazard Labels

McCoy Global uses four levels of hazard / notice labels to describe items of four levels of importance:

DANGER is represented by a hazard symbol coupled with a “**DANGER**” signal word, and identifies items of the highest level of risk. Failure to heed information identified by a **DANGER** symbol may result in severe bodily injury or death.

 **DANGER**

THIS IDENTIFIES AN EXTREME HAZARD OF PERSONAL INJURY OR DEATH

A **WARNING** is represented by a hazard symbol coupled with a bold “**WARNING**” signal word, and identifies items of medium risk. Failure to heed information identified by a **WARNING** symbol may result in significant injury to personnel, catastrophic equipment failure, or harmful environmental contamination.

 **WARNING**

THIS IDENTIFIES A WARNING REGARDING POTENTIAL INJURY OR CATASTROPHIC EQUIPMENT DAMAGE

A **CAUTION** is represented by a hazard symbol coupled with a bold “**CAUTION**” signal word, and identifies items of low risk. Failure to heed information identified by a **WARNING** symbol may result in injury to personnel or equipment damage.

 **CAUTION**

THIS IDENTIFIES A CAUTION REGARDING SAFE OPERATION OR THE POTENTIAL OF EQUIPMENT DAMAGE

A **NOTICE** highlights information or items of importance unrelated to personal injury that may aid the user during installation, commissioning, assembly, or operation of your equipment.

NOTICE

THIS HIGHLIGHTS ITEMS OF IMPORTANCE UNRELATED TO PERSONAL INJURY

1.2.2 General Safe Operating Guidelines

Only authorized personnel shall operate equipment delivered by McCoy Global. Equipment shall be in a proper technical condition prior to use, and shall be used only for the purpose for which it is intended. Malfunctions or damages must be rectified before operation to ensure personnel safety and avoid equipment damage.

The user is responsible for ensuring the safety of all personnel while operating any McCoy Global product. McCoy Global is not responsible for injuries or equipment damage that arises from improper use of the equipment.

McCoy Global recommends that a hazard assessment of the work area be performed by a designated safety representative before commencing operations. A designated safety representative is responsible for verifying that all operators have adequate equipment and safety training.

1.2.2 General Safe Operation Guidelines (Continued):

The area surrounding the equipment operating area must be clutter-free and free from tripping hazards, or protruding objects that may snag hoses or cables. Operating surface or drill floor must be kept free of slipping hazards like grease, oil, water, etc.

Adequate lighting of the work area is required. All warnings, labels, gauges, and signs must be clearly visible.

Equipment components painted green are safe for continuous handling. Areas painted yellow and any other equipment components that rotate or move are designated as hazardous areas. Contact with those areas must be avoided during operation.



Illustration 1.2.1: Equipment Handling Warnings

Always wear all personal protective equipment (PPE) specified by established HSE policies. Follow all safety guidelines.

Never attempt to clamp to a tubular using incorrectly sized dies. Operators must always use the correct jaw size equipped with the proper dies. Use of incorrectly size dies poses a hazard to personnel and may damage equipment. Please see Section 3 of this manual for a list of compatible jaw die kits and replacement dies.

! WARNING

NEVER ATTEMPT TO CLAMP ONTO TUBULARS WITH INCORRECTLY SIZED DIES

! WARNING

BY NATURE, STEEL MACHINERY WITH ROTATING AND MOVING PARTS HAS THE POTENTIAL TO GENERATE IGNITION SOURCES, IE. SPARKS. AS OUTLINED IN THIS MANUAL, SCHEDULED MAINTENANCE, LUBRICATION, TIMELY REPLACEMENT OF WORN COMPONENTS AND MOST IMPORTANTLY, ON-SITE RISK ASSESSMENTS WITH STRINGENT STANDARD OPERATING PROCEDURES ARE ALL REQUIRED TO PREVENT THE POTENTIAL OF SPARK GENERATION.

! WARNING

FAILURE TO FOLLOW THE EQUIPMENT PLACEMENT/RIG-UP PROCEDURES OUTLINED IN THIS MANUAL MAY LEAVE EQUIPMENT UNGROUNDED AND AT RISK FOR BUILDING A STATIC CHARGE. ASSESSMENT FOR PROPER GROUNDING MUST BE PERFORMED PRIOR TO OPERATION IN ORDER TO MITIGATE THE SPARK RISKS ASSOCIATED WITH STATIC DISCHARGE.

1.2.3 Rigging and Overhead Lifting

McCoy Global recommends following an industry-accepted standard such as OSHA, ASME B30.9-2006, or manufacturer's guidelines when performing any rigging and overhead lifting. Use by untrained persons is hazardous. Improper use will result in serious injury or death. Do not exceed rated capacity. Slings will fail if damaged, abused, misused, overused, or improperly maintained. Never stand beneath a suspended load.



DANGER

NEVER STAND BENEATH A SUSPENDED LOAD

1.2.4 Maintenance Safety

All personnel are responsible for performing maintenance tasks in a manner that ensures worker, equipment, and environmental safety, and may require taking additional steps that are not identified in this section.

Maintenance of equipment shall be performed only by designated qualified maintenance personnel. Do not begin a maintenance task without the proper tools or materials on hand, or the proper drawings and documentation necessary.

Isolate the location of the maintenance under way to prevent unaware personnel from inadvertently exposing themselves to a hazard. Use tape, rope, or signage to clearly indicate "off-limits" area.

Where applicable ensure electrical circuits within the affected equipment are deactivated or de-energized by an authorized, qualified person and locked out if necessary. Do not disconnect a live electrical circuit unless location is known to be non-hazardous.



DANGER

ALWAYS MEASURE ELECTRICAL CIRCUITS TO CONFIRM DEACTIVATION BEFORE PROCEEDING WITH MAINTENANCE



WARNING

WHEN REPAINTING EQUIPMENT, THE PAINT COAT BEING APPLIED SHOULD NEVER EXCEED 2MM IN THICKNESS. EXCEEDING THIS THICKNESS MAY FACILITATE STATIC CHARGE BUILDUP AND PRESENT A POSSIBLE SPARK RISK ASSOCIATED WITH STATIC DISCHARGE.

1.2.5 Replacement Parts

All consumable and replacement parts must meet or exceed OEM specifications in order to maintain equipment integrity. Do not replace protective equipment such as hydraulic switches, circuit breakers, and fuses without first consulting with McCoy Global. Do not replace electrical or control hardware without consulting with McCoy Global. Using non-OEM replacement parts without the approval of McCoy Global may void equipment warranty.

1.2.6 Environmental Impact

McCoy Global equipment uses materials that may be harmful to the environment if improperly disposed of (hydraulic fluid, grease, fuel, electrical components, etc.). Dispose of all materials according to established environmental protection regulations in conjunction with published federal, state, provincial, and civic legislation.

In all cases observance of the following is the full responsibility of the user:

- **all descriptions, information and instructions set out in this manual**
- **any regulation or requirement issued by an authority or agency which may influence operation, safety or integrity of the equipment that overrules the content of this document.**
- **any legal or other mandatory regulation in force governing accident prevention or environmental protection.**

1.3 ACRONYMS AND TERMINOLOGY

1.3.1 Acronyms and Definitions

| ACRONYM | DEFINITION |
|---------|---|
| ANSI | American National Standards Institute |
| API | American Petroleum Institute |
| ASME | American Society of Mechanical Engineers |
| ATEX | Appareils destinés à être utilisés en AT mosphères EX plosibles |
| BDC | Bottom dead centre |
| CBU | CLINCHER [®] -style backup |
| CE | Conformité Européenne |
| CCW | Counter-clockwise |
| COG | Centre of gravity |
| CW | Clockwise |
| DS | Driller's side |
| EU | European Union |
| HMI | Human-machine interface |
| HPU | Hydraulic power unit |
| HSE | Health, Safety, and Environmental (context: protection) |
| ID | Inside diameter |
| ISO | International Organization for Standardization |
| JDK | Jaw die kit |
| JSA | Job safety assessment |
| LH | Left-hand |
| LJBU | LOCKJAW [™] backup |
| MBU | "McCoy style" backup |
| N/A | Not applicable or Not available (context-dependant) |
| NLGI | National Lubricating Grease Institute |
| ODS | Off-driller's side |
| OEM | Original equipment manufacturer |
| OSHA | Occupational Safety and Health Administration |
| OD | Outside diameter |
| PLC | Programmable Logic Controller |
| PPE | Personal Protective Equipment |
| PSI | Pounds per square inch (pressure) |
| RH | Right-hand |
| VAC | Volts, alternating current |
| VDC | Volts, direct current |

1.3.2 Terms and Definitions

| TERM | DEFINITION |
|----------------|--|
| ATEX-certified | Conforms with the EU “ATEX” directive for equipment operated within an explosive atmosphere. |
| Backup | The component of a tong-backup arrangement that mechanically attaches to the stationary side of a tubular connection and provides resistance to the tong when making up or breaking out a joint. |
| Box | The female side of a pipe connection |
| Break Out | Loosening, un-threading, and disconnecting a connection (typically a tubular connection). The term may also apply to a general threaded connection. |
| CE-marked | CE compliant. Conforms with the essential requirements of the applicable Conformité Européenne directives. |
| Clamp | To grasp the stationary side of a pipe joint with a backup. |
| Die | A component of a jaw die kit that provides the mechanical contact between the tong and the tubular. |
| Joint | Also called a “pipe joint”. A threaded tubular connection. |
| Load Cell | A hydraulic device that transmits a proportional signal to a torque gauge for the purpose of measuring connection torque. |
| Make Up | Threading together a connection (typically a tubular connection) and tightening to a specified torque. The term may also apply to a general threaded connection. |
| Pin | The male side of a pipe connection |
| Ring Gear | The rotating component, mechanically coupled to a hydraulic motor through a gear train, which provides rotation to the pin-side of a tubular connection through the use of jaw assemblies |
| Door Switch | A device mechanically connected to the door of a hydraulic power tong that uses hydraulic switching to prevent rotation of the cage plates when the tong door is open. |
| Sling | A rigid or non-rigid device used to hoist a piece of equipment using a crane. |
| Tank | Hydraulic fluid reservoir |
| Tong | The component of a tong-backup arrangement that mechanically attaches to the tubular connection and rotates the tubular to make up or break out a connection |
| Un-clamp | To release the stationary side of a pipe joint with a backup. |
| WINCATT® | Data acquisition and torque/turns management system manufactured by McCoy Global |
| Headstock | The tong assembly on a horizontal bucking unit |
| Tailstock | The backup assembly on a horizontal bucking unit |



**This page intentionally
left blank**



SECTION 2: EQUIPMENT & LUBRICATION SPECIFICATIONS



**This page intentionally
left blank**

2.0 EQUIPMENT DESCRIPTION

This manual provides operational & maintenance instructions as well as spare parts assemblies for the McCoy RP6012 Bucking Unit. The RP6012 is a rugged, self-contained, continuously rotating unit designed to accurately make up or break out threaded connections on tubular components such as oil and gas well drilling tools, casing, tubing, and similar equipment.

Features of the McCoy RP6012 Bucking Unit include:

- E-Stop circuit that will stop the movement of the Bucking Unit
- Control console with integrated power unit
- Available optional accessories

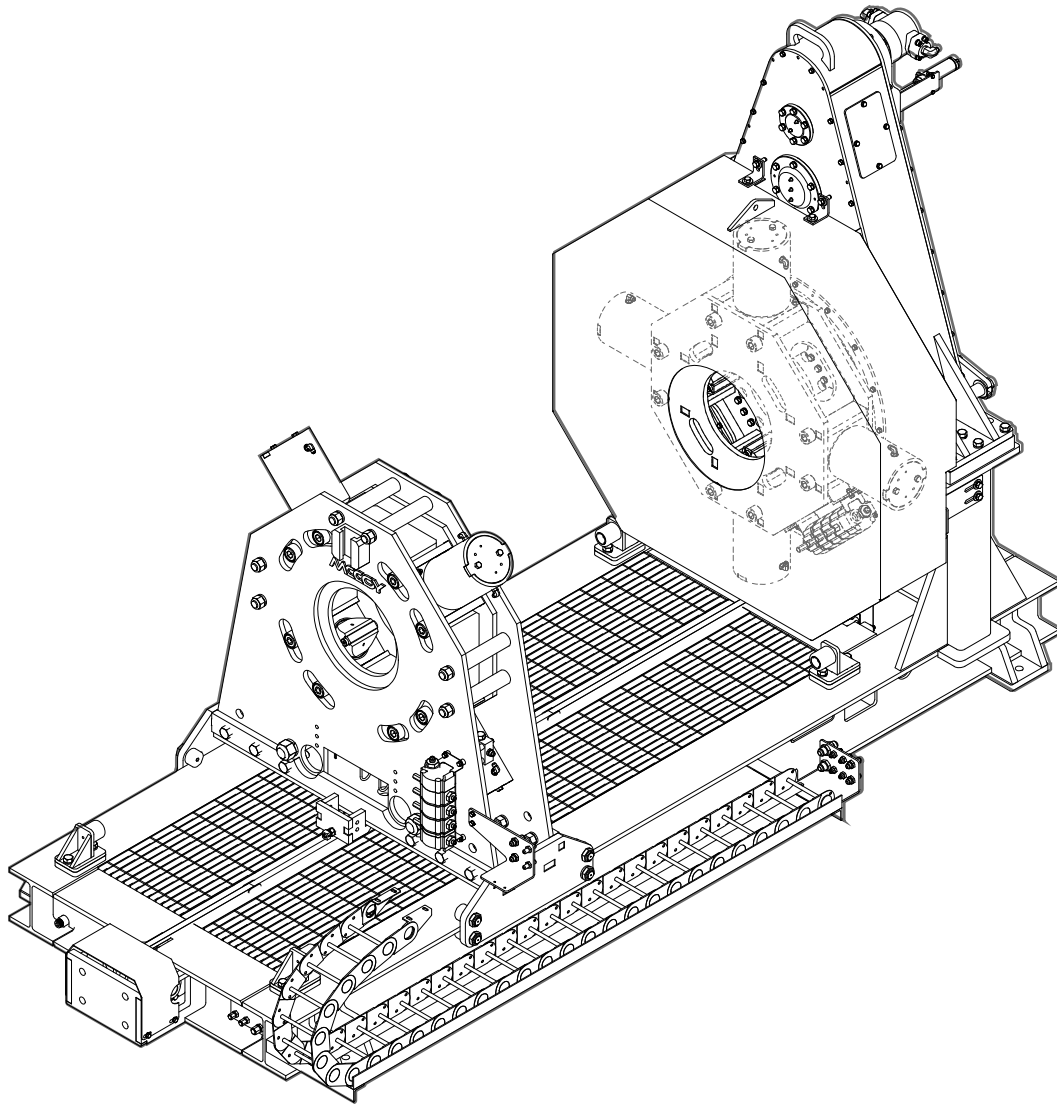

Illustration 2.0.1: RP6012 Bucking Unit



**This page intentionally
left blank**

! WARNING

ANY MOVING OR ROTATING COMPONENT OF THIS EQUIPMENT PRESENTS SIGNIFICANT HAZARDS WHEN THE EQUIPMENT IS ACTIVE. KEEP CLEAR OF UNIT WHILE ENERGIZED. DO NOT STEP ON ANY PART OF THE EQUIPMENT BED WHEN THE EQUIPMENT IS ACTIVE.

THE AREAS HIGHLIGHTED IN YELLOW ON THIS PAGE INDICATE POTENTIAL PINCHING, CRUSHING AND SNAGGING HAZARDS DURING OPERATION. IN ADDITION, HAZARDOUS AREAS ON UNIT ARE MARKED BY YELLOW/BLACK STRIPED HAZARD TAPE. KEEP CLEAR OF INDICATED AREAS WHEN EQUIPMENT IS ENERGIZED.

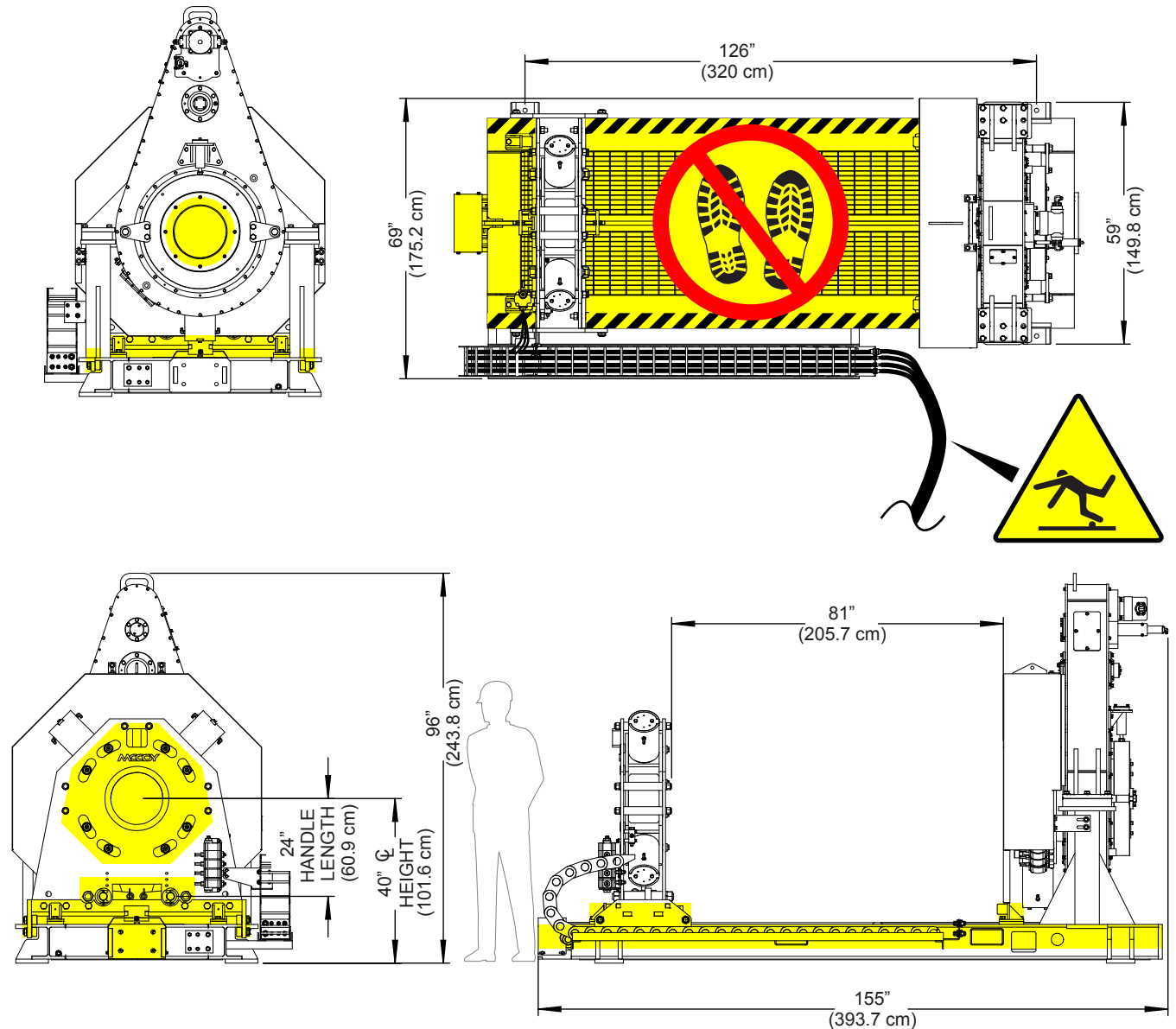
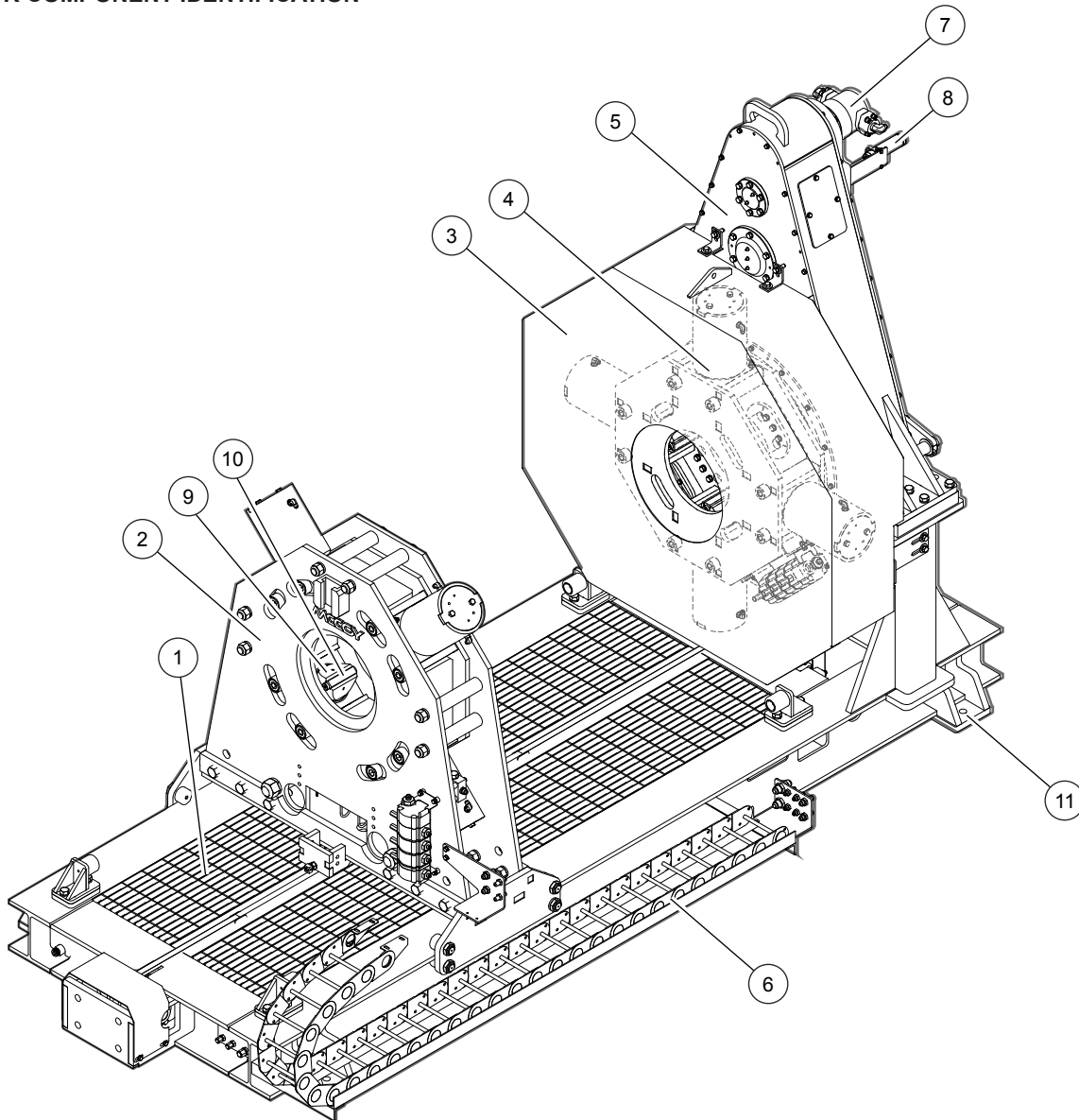

Illustration 2.0.2: RP6012 Dimensions & Hazard Areas

2.1 MAJOR COMPONENT IDENTIFICATION



| Item | Description |
|------|-------------------------|
| 1 | Skid Assembly |
| 2 | Backup Assembly |
| 3 | Tong Guard Assembly |
| 4 | Tong Vise Assembly |
| 5 | Tong Assembly |
| 6 | Hose Track Assembly |
| 7 | Hydraulic Motor |
| 8 | Shift Cylinder Assembly |
| 9 | Jaw |
| 10 | Jaw Die |
| 11 | Anchor Foot |

Illustration 2.1.1: RP6012 Component Identification

2.1 MAJOR COMPONENT IDENTIFICATION (CONTINUED):

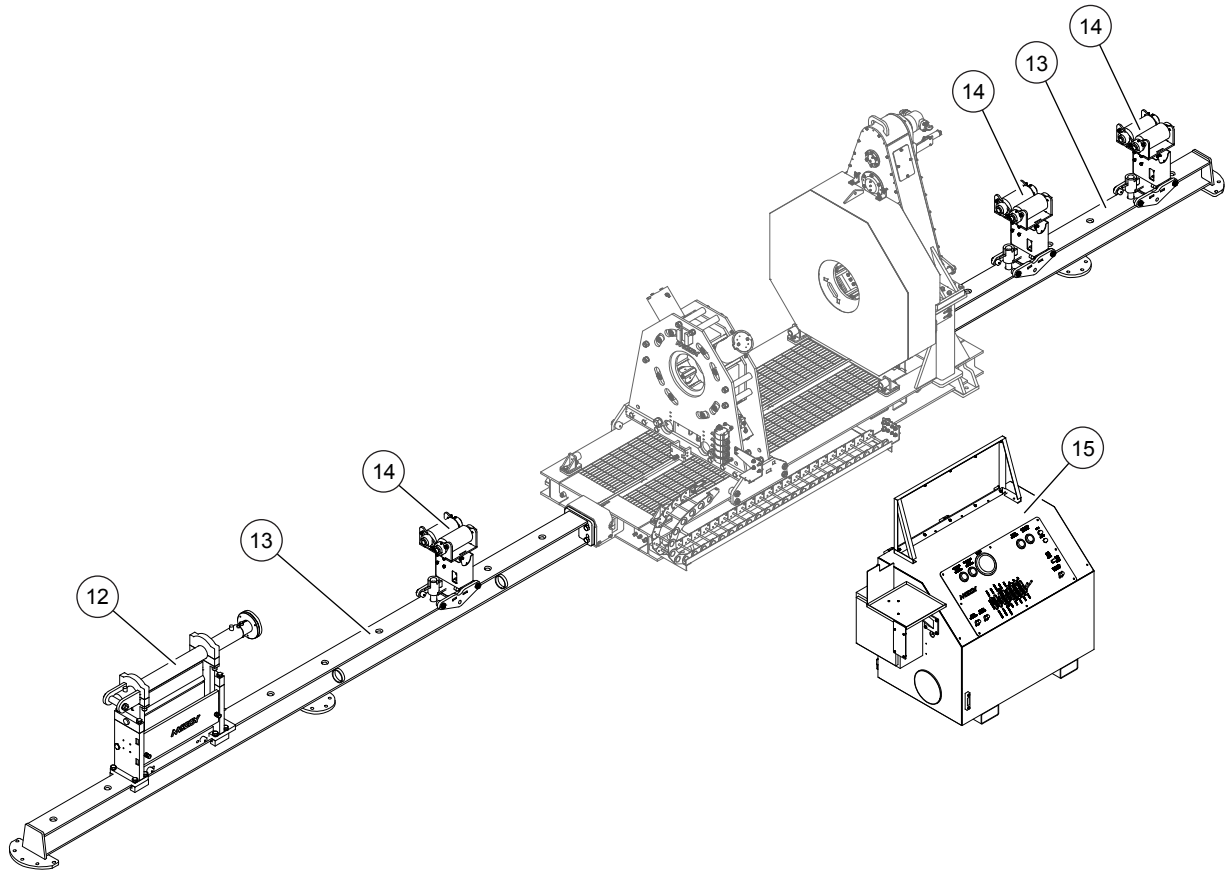

| Item | Description |
|------|---------------------------------|
| 12 | Push/Pull Assembly |
| 13 | Extension Beam Assembly |
| 14 | Hydraulic Support Jack Assembly |
| 15 | Control Console Assembly |

Illustration 2.1.2: RP6012 with Optional Accessories

2.2 EQUIPMENT SPECIFICATIONS

Torque Table

Please note that these are ideal values. Actual achieved torque is highly dependent upon tong efficiency and final position of rotary gear when full torque load is reached. Maximum torque is only available in low gear and full motor displacement.

| Pressure | HIGH Speed | | LOW Speed | |
|--|------------|--------|-----------|--------|
| PSI / Bar | Lbs.-ft. | Nm | Lbs.-ft. | Nm |
| 1200 / 82.74 | 4,300 | 5,830 | 21,000 | 28,472 |
| 2000 / 137.90 | 7,200 | 9,761 | 35,000 | 47,453 |
| 2700 / 186.16 | 9,700 | 13,151 | 47,500 | 64,401 |
| MAXIMUM RATED TORQUE: 50,000 LBS-FT / 67,790 NM | | | | |
| MAXIMUM SYSTEM PRESSURE: 3,000 PSI / 206.1 BAR | | | | |

Speed Table (RPM - Theoretical Estimates)
@ 2700 PSI

| Flow (GPM/LPM) | HIGH Gear (RPM) | LOW Gear (RPM) |
|-------------------|--------------------|-------------------|
| 10 / 37.9 | 6 | 1 |
| 20 / 75.7 | 12 | 2 |
| 26.4 / 99.9 | 15 | 3 |

| | |
|---|--|
| Maximum Hydraulic Requirements | 47 GPM (151.4 LPM) |
| | 3000 PSI (20.684 MPa) |
| Dimensions (without accessories) | See page 2.5 |
| Min. Center-to-Center Die Distance | 20 in / 508 mm |
| Torque Arm Length (pipe center to anchor center) | 24 in / 609.6 mm |
| Gear Reduction Ratio, Turns Encoder Mount to Ring Gear | 7.09:1 |
| Dead Weight (approx. without accessories) | 11,300 lbs / 5,125 kg |
| Tong Gripping Capacity | 2-3/8 in (60.3 mm) to 12-1/4 in (311.1 mm) |
| Backup Gripping Capacity | 2-3/8 in (60.3 mm) to 12-1/4 in (311.1 mm) |
| Noise Emissions | A-weighted (average) 74.4 dB |
| | C-weighted (peak) 84.4 dB |
| | A-weighted (sound power) 80 dB |

2.3 RECOMMENDED LUBRICANT SPECIFICATIONS

2.3.1 Hydraulic Fluid

McCoy Global recommends using high-quality hydraulic fluid containing rust & oxidation inhibitors and foam suppressant that meets the following requirements. Operating this equipment using hydraulic fluid that does not meet these requirements greatly accelerates equipment damage due to (but not limited to) premature component wear, premature seal failure, cavitation, and fluid starvation.

⚠ CAUTION

OPERATING THIS EQUIPMENT USING HYDRAULIC FLUID THAT DOES NOT MEET THE LISTED REQUIREMENTS GREATLY ACCELERATES EQUIPMENT DAMAGE.

| Hydraulic Fluid Standards | |
|---|---|
| Characteristic | Requirement |
| Maximum viscosity at cold startup | <1000 cSt (<4600 SUS) |
| Operating viscosity range | 100 to 16 cSt (170 to 80 SUS) |
| Minimum viscosity (intermittent periods only) | 10 cSt (60 SUS) |
| Hydraulic fluid operating temperature range | 86 - 140°F (30 - 60°C) - measured in main reservoir |
| Maximum fluid temperature | 180°F (82°C) |
| Fluid cleanliness | Filtered to ISO 4406:1999 (22/18/13) |

Hydraulic fluid should be chosen with due regard to expected climactic conditions and equipment load. Note that this equipment may have been tested using hydraulic fluid that does not meet operational requirements beyond those specified in the above table. Therefore, McCoy recommends purging and flushing the equipment’s hydraulic system before connecting to a hydraulic supply.

NOTICE

MCCOY GLOBAL RECOMMENDS PURGING AND FLUSHING THE EQUIPMENT’S HYDRAULIC SYSTEM BEFORE CONNECTING TO A HYDRAULIC SUPPLY.

2.3.2 Grease

McCoy Global recommends use of a high-quality EP multi-purpose grease with an NLGI consistency grade of "2" and an NLGI performance grade of "GC-LB" for general lubrication of bearings and metal-to-metal contact.

McCoy Global recommends thoroughly greasing the equipment before first use as per the lubrication instructions in Section 5.



**This page intentionally
left blank**



SECTION 3: INSTALLATION & COMMISSIONING



**This page intentionally
left blank**

Adequate setup and proper hydraulic connections are essential in ensuring reliable operation of your McCoy equipment. For best results and long term reliability, read and obey the installation and commissioning instructions in this section.

3.0 RECEIPT, INSPECTION, AND HANDLING OF EQUIPMENT

CAUTION

YOUR EQUIPMENT HAS BEEN THOROUGHLY TESTED AND INSPECTED AT THE FACTORY. HOWEVER, MCCOY ADVISES INSPECTING YOUR EQUIPMENT FOR SHIPPING DAMAGE UPON RECEIPT AND TESTING YOUR EQUIPMENT BEFORE RELEASING TO AN OPERATIONAL ENVIRONMENT.

Upon receipt inspect packaging materials for shipping damage. Shipping damage may include (but not be limited to) perforation of a crate, misshapen crate, crushed corners, missing hardware, scraped or bent metal, and impact or orientation indicators (like a tip'n'tell). Record all shipping damage on the shipping manifest and ensure the shipping company and McCoy are immediately contacted.

Remove all protective shipping materials including plastic wrap, desiccant packs, padding, wooden beams, etc and perform a visual inspection of the equipment. Check structural components for bending or buckling indicative of impact. Immediately identify any shipping damage to the shipping company, and correct all damage before connecting equipment to a hydraulic power source.

CAUTION

EQUIPMENT MAY HAVE SHIPPING COMPONENTS INSTALLED WHICH SERVE TO STABILIZE MOVING COMPONENTS DURING SHIPPING. ALL SHIPPING COMPONENTS MUST BE REMOVED PRIOR TO USE. FAILURE TO DO SO MAY CAUSE EQUIPMENT DAMAGE.

3.0 RECEIPT, INSPECTION, AND HANDLING OF EQUIPMENT (CONTINUED):

3.0.1 Lifting with a Forklift

When lifting the bucking unit, the backup must be extended to its maximum extended position along the skid in order for the equipment to remain balanced.

1. Extended the backup to its maximum extension position horizontally along the skid to maintain balance when lifting.
2. Insert two (2) wooden 4x4's snugly between the backup and tong so that the backup cannot move horizontally along the skid.
3. Lift equipment with adequately rated forklift through forklift tubes located on the base of the skid.

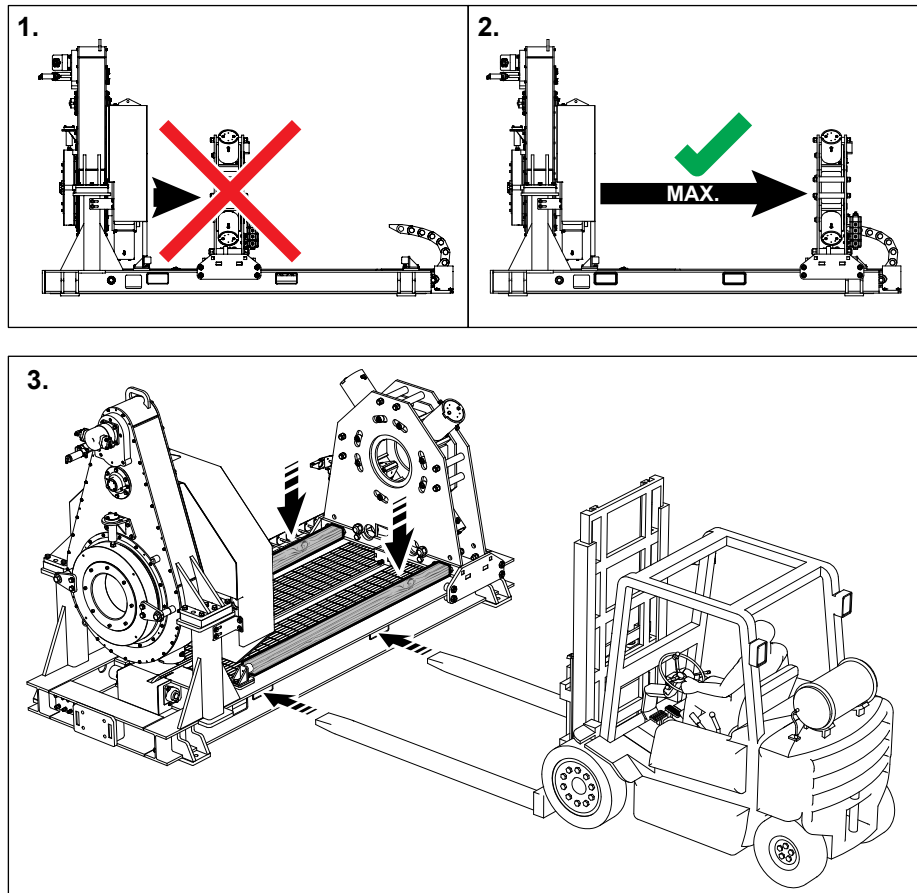

Illustration 3.0.1: RP6012 Forklift Lifting Procedure

WARNING

THE BACKUP MUST BE EXTENDED TO ITS MAXIMUM EXTENDED POSITION ALONG THE SKID IN ORDER FOR THE EQUIPMENT TO REMAIN BALANCED FOR LIFTING. FAILURE TO DO SO MAY RESULT IN AN UNBALANCED LOAD, CREATING THE POTENTIAL FOR EQUIPMENT DAMAGE AND INJURY TO NEARBY PERSONNEL.

3.1 ANCHORING THE UNIT IN PLACE (OPTIONAL)

McCoy Continuously Rotating Bucking Units and Make/Break Machines are designed so that their structure is able to withstand the maximum torsional forces the machine can develop without relying on external anchoring or reinforcement. Equipment designs include mounting feet to accommodate anchor bolts, leveling jack bolts, and axial alignment adjustment fittings. McCoy drawings are available which include the locations and specifications for anchors which will secure equipment to the foundation, ensuring the equipment remains in alignment with pipe roller systems that are used to install or remove tubulars.

Due to the varying nature of installation sites, McCoy cannot provide site specific foundation design recommendations; only general foundation requirements. McCoy encourages customers to utilize locally licensed engineers and contractors who will have knowledge specific to plant needs, local building codes, soil properties at the installation site, and the impact of seasonal environmental changes on the underlying soil structure. In many cases, equipment will be installed on preexisting concrete slabs of unknown composition, strength, and thickness with unknown reinforcing member design or status of critical moisture barriers. Additionally, existing foundations may contain conduit or piping that must be considered with developing a foundation and installation plan. It also may be desirable to install equipment in recessed areas located in the slab. Local contractors will consider site conditions, building codes, and safety requirements to insure the installation will satisfy customer needs and will be in compliance with all governing regulations.

McCoy Bucking Units are not generally thought of in terms as machines which can generate heavy shock loads or vibrations that can be transferred through the foundation to other equipment. This should be considered when establishing the installation plan. In new installations, consideration should be given to installing bent anchor bolts or headed anchor bolts in place prior to pouring the concrete. McCoy recommends the use of high strength anchor bolts conforming to the F1554 Grade 105 requirements or better. Alternatives for existing foundations that can be evaluated by contractors include grouting these anchors in place or wedge type anchor bolt systems.

McCoy's Service Technicians are available to provide guidance and recommendations to customers, their employees, and contractors regarding the proper installation and startup of this equipment, as well as for the training of customers' operators.

CAUTION

MCCOY STRONGLY RECOMMENDS THE USE OF LASER ALIGNMENT TOOLS TO VERIFY PROPER ALIGNMENT PRIOR TO PERMANENTLY FIXING ANY ANCHOR BOLTS. FAILURE TO CORRECTLY ALIGN RACK CENTERLINE WITH BUCKING UNIT MAY CAUSE TUBULARS TO HANG ON DIES WHEN PASSING THROUGH THE BUCKING UNIT, RESULT IN UNACCEPTABLE TORQUE TURN RESULTS, AND CAUSE DAMAGE TO EQUIPMENT.

3.2 HYDRAULICS & ELECTRONICS

3.2.1 Bucking Unit Hydraulic Schematic

NOTE: TRAVERSE MOTOR OPTIONAL

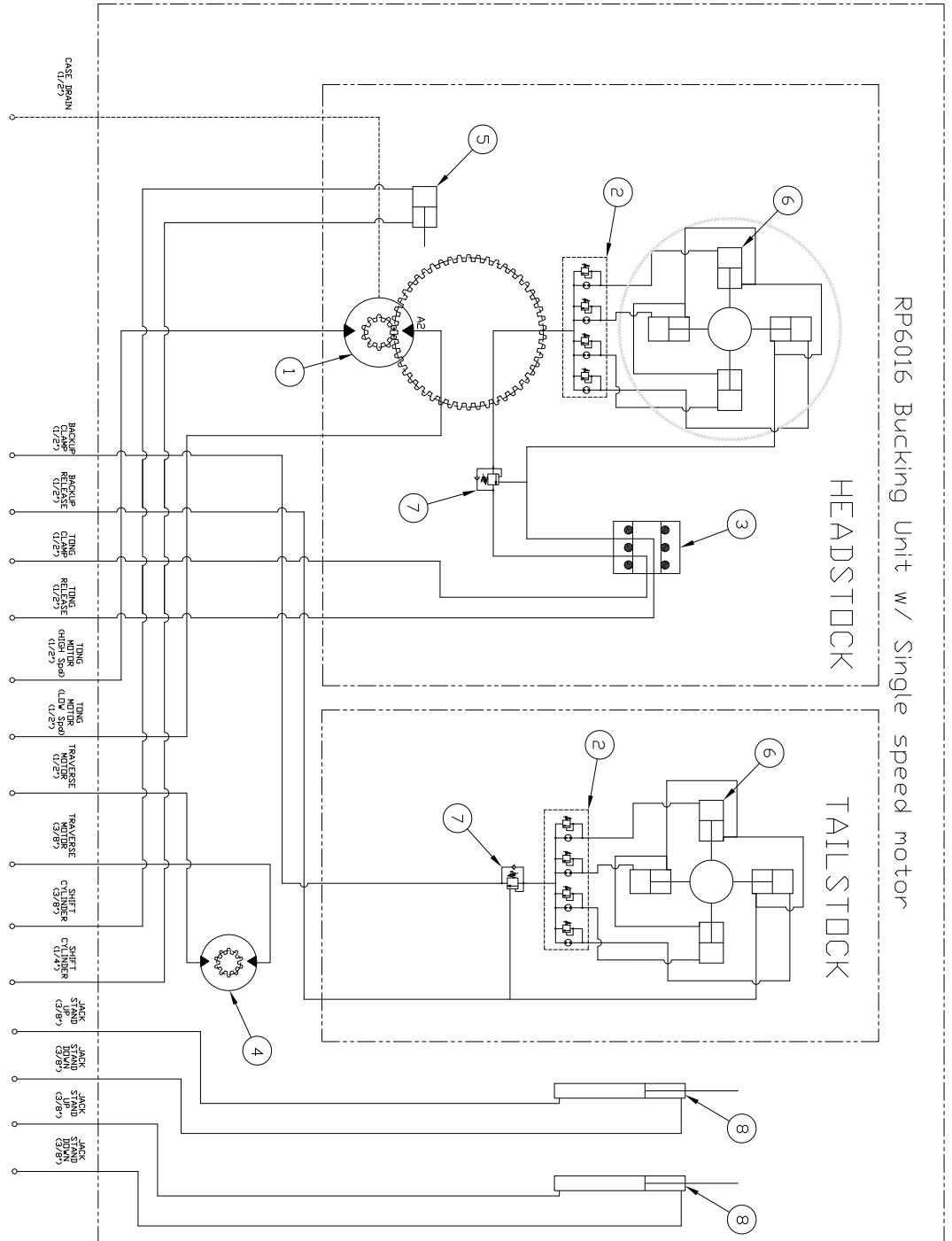

| ITEM NO. | QTY. | DESCRIPTION | PART NUMBER |
|----------|------|-------------------------|--------------|
| 1 | 1 | HYDRAULIC MOTOR, SINGLE | 235-6500 |
| 2 | 2 | FLOW DIVIDER | 330-6500 |
| 3 | 1 | HYDRAULIC SWIVEL | 2026-6500-01 |
| 4 | 1 | TRAVERSE MOTOR | 511-6500 |
| 5 | 1 | AIR CYLINDER | 234-6500 |
| 6 | 8 | CLAMP CYLINDER | 400-3000-1 |
| 7 | 2 | VALVE, COUNTERBALANCE | 340-3500 |
| 8 | 2 | CYLINDER, ASSEMBLY | 901D-3000-2 |

3.2.2 Main Hydraulic Connections

Hydraulic hoses are connected to the console through the hydraulic bulkhead located on the side of the power unit, as well as the bulkhead located on the skid of the bucking unit. When connecting to hydraulic equipment, match the tag numbers attached to hydraulic hoses to the matching connection number on the hydraulic bulkhead. See Control Console / Power Unit manual for more information.

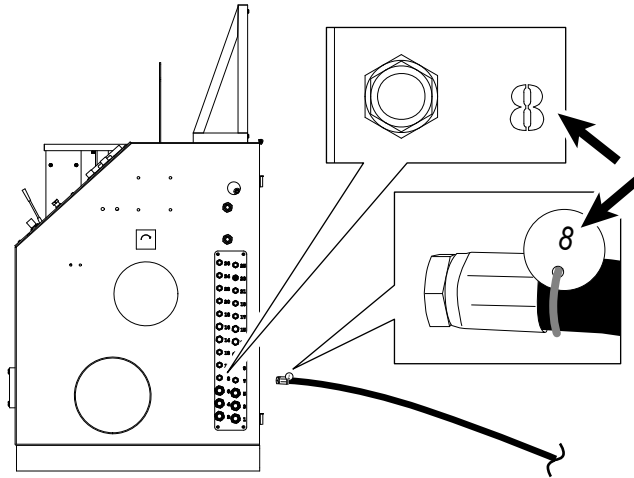

Illustration 3.2.1: Hydraulic Connection Cleaning / Maintenance

Inspect all connectors for damage, debris, or other contaminants before performing hydraulic connections. Clean connectors using compressed air or an approved cleaning solvent and lint-free cloth. Always cover disconnected fittings with clean brass or plastic dust caps, typically attached to each connector with a lightweight chain or flexible line. These caps provide significant protection from dust, dirt, other contaminants, and impact damage.

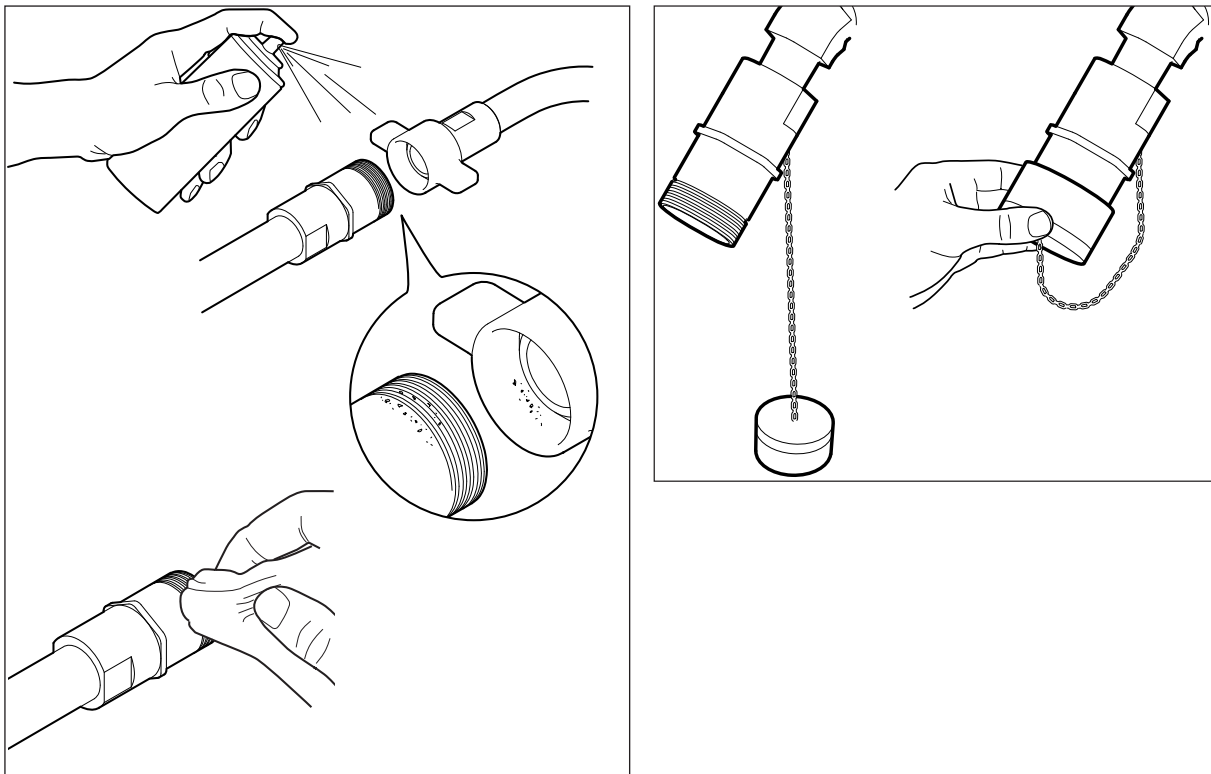

Illustration 3.2.2: Hydraulic Connection Cleaning / Maintenance

3.2.2 Main Hydraulic Connections (Continued):

Hydraulic connections should only be broken out or made up when the hydraulic system is de-energized.

All protective caps and plugs must be removed before attempting to make up connections. Hydraulic disconnects should always be fully made up to the “fully engaged” position. Inspect all hydraulic connections before energizing hydraulic power to ensure secure connections have been made. Supplying full hydraulic pressure without ensuring an established return line may result in system damage.

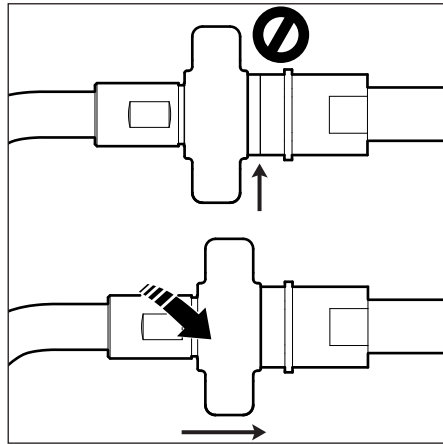

Illustration 3.2.2: Securing Hydraulic Connections

Inspect these connections upon activation of the power unit. Leaking components must be repaired before releasing the tong to the operational environment. Deactivate the power unit and depressurize the hydraulic system according to the procedure in Section 4. Disconnect the main hydraulic connections and inspect all four connectors (two male, two female) for damage or debris. If the connectors cannot be cleaned or easily repaired, McCoy recommends replacement of the leaking connector. Note that damage to one of the connectors may have caused damage to its mate.

Turn off power unit and depressurize hydraulic system before disconnecting the main hydraulic lines under normal working conditions. See Section 4 for hydraulic system depressurization. McCoy recommends placing protective caps over the exposed connectors to protect them from water and impact damage.

WARNING

ALWAYS TURN OFF HYDRAULIC POWER AND DEPRESSURIZE HYDRAULIC SYSTEM BEFORE DISCONNECTING MAIN HYDRAULIC LINES. SEE PAGE 5.4 FOR DEPRESSURIZATION PROCEDURE.

3.3 TONG / BACKUP JAW DIE AVAILABILITY & INSTALLATION

3.3.1 Strip Die Availability

The clamping cylinder jaws on this bucking unit accept standard strip dies. Please refer to our website for complete information on available dies:

<http://www.mccoysglobal.com/dies-inserts>

WARNING

NEVER ATTEMPT TO CLAMP ONTO TUBULARS WITH INCORRECTLY SIZED DIES. OPERATORS MUST BE AWARE OF THE SIZE OF TUBULAR TO BE GRIPPED AND THAT THE JAW AND DIE SYSTEM IN USE IS PROPERLY SIZED. USE OF INCORRECTLY SIZE DIES POSES A HAZARD TO PERSONNEL AND EQUIPMENT.

3.3.2 Jaw/Jaw Die Installation & Removal

1. Extend clamping cylinders so that die keeper fasteners bolts may be accessed.
2. Shut down and completely disconnect hydraulic power from the tool.

DANGER

ISOLATE BUCKING UNIT FROM HYDRAULIC POWER BEFORE PROCEEDING WITH JAW OR JAW DIE REPLACEMENT.

5. Extract the keeper fasteners and, if required, use a hammer and soft metal drive tool to tap the worn dies from the bottom (depending on orientation) to remove.
6. Clean the dovetail die slots using a metal brush.
7. Assure jaw retainer bolt is torqued to 180 ft-lbs (244 Nm).
8. Treat the new dies with anti-seize compound before installing.
9. Insert the new jaw dies in to the jaw(s). If required, use a non-metallic mallet or hammer and soft metal drive to tap the die inserts fully in to place.
10. Replace the die keeper fasteners and secure in place.

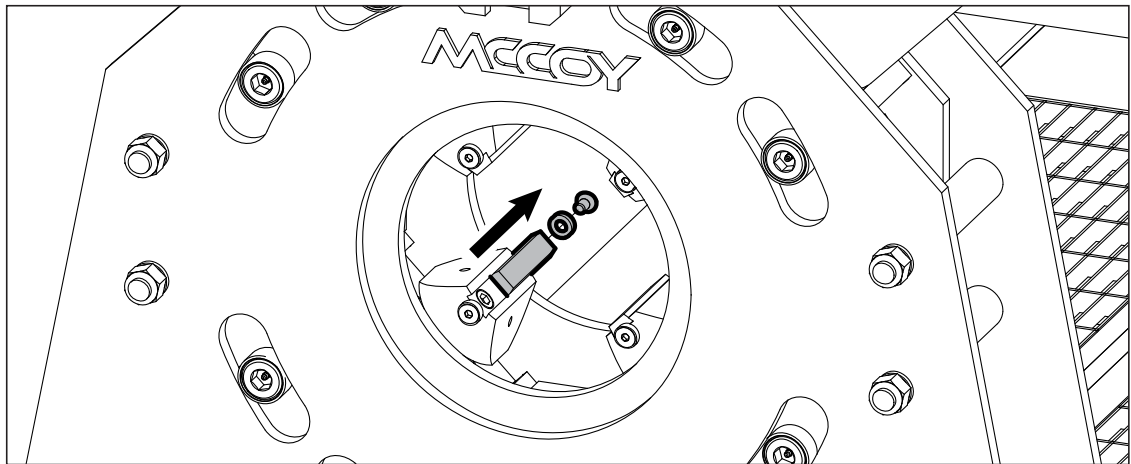

Illustration 3.3.1: Jaw Die Removal

CAUTION

JAWS MAY PRODUCE METAL SHAVINGS. WEAR STURDY WORK GLOVES WHEN HANDLING JAW DIE KITS.

3.4 UNIT PLACEMENT & SETUP

3.4.1 Operational Surface

The bucking unit must be placed on a level surface for operation. Placing the unit on an uneven surface may result in jaw slippage or failure of jaw components.

⚠ CAUTION

FAILURE TO PLACE THE UNIT ON A LEVEL SURFACE MAY RESULT IN JAW SLIPPAGE OR FAILURE OF JAW COMPONENTS.

3.4.2 Component Placement

When setting up the work area, it is critical to take into account space needed for the following:

- Placement of the Control Console so that the operator has a clear line of sight over all equipment components (and their full range of motion) during operation
- Operators are situated behind Control Console Safety Shield
- A minimum of 3 ft. (91.4 cm) clear space is maintained around the unit to accommodate maintenance efforts
- Any surrounding personnel are a minimum of 3 ft. (91.4 cm) away from equipment and tubular loading areas

⚠ WARNING

THE EQUIPMENT OPERATOR MUST MAINTAIN A CLEAR LINE OF SIGHT OF ALL EQUIPMENT COMPONENTS DURING OPERATION. ALL PERSONNEL MUST STAY CLEAR OF EQUIPMENT DURING OPERATION.

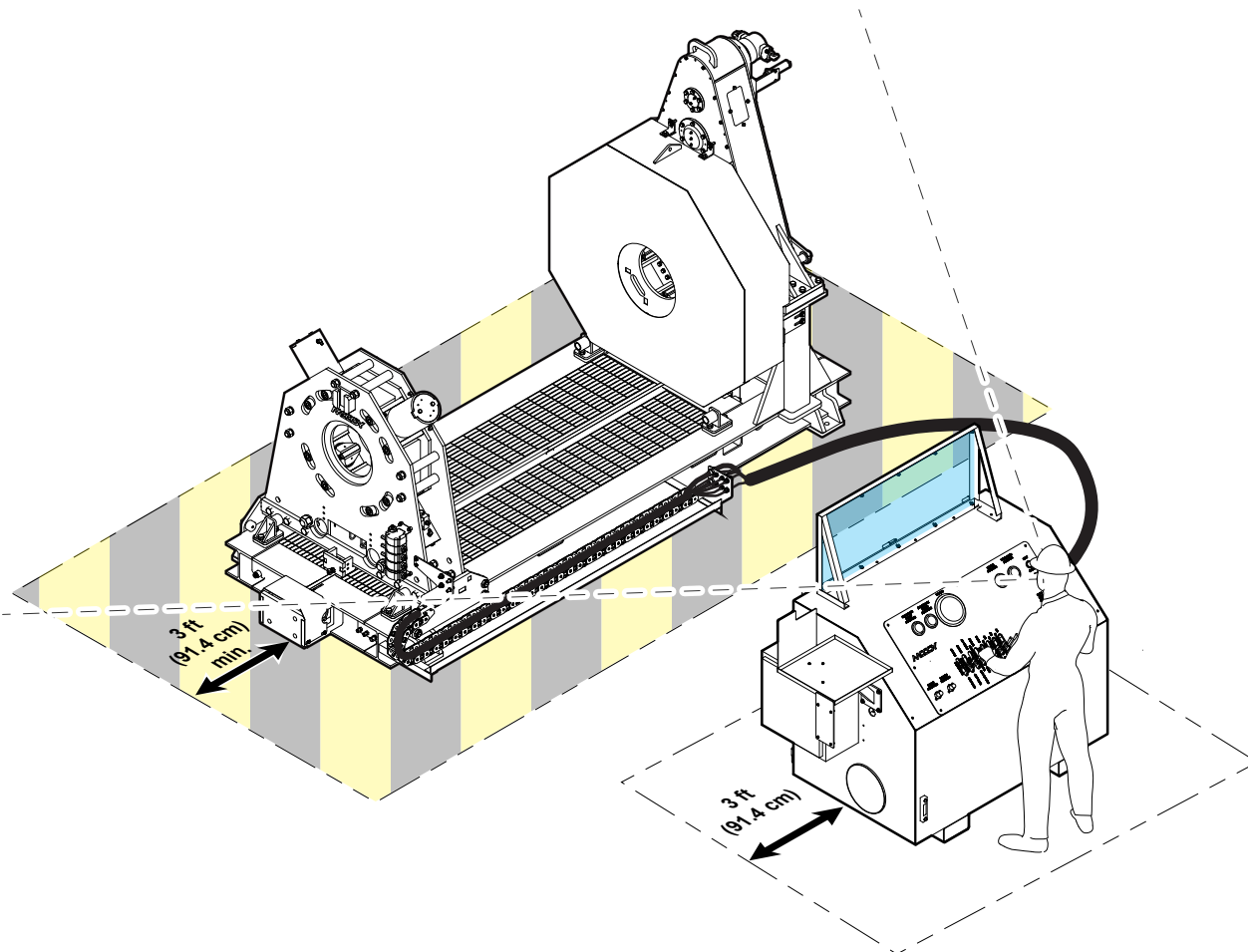

Illustration 3.4.1: Operator Line of Sight & Equipment Placement

3.4.3 Load Cell Configuration

The bucking unit accepts pin style load cells that are loaded into the base of the backup. It is important to note that most pin style load cells must be loaded in a particular orientation in order to register correct readings and avoid potentially damaging the load cell.

! CAUTION

MOST PIN-STYLE LOAD CELLS MUST BE INSTALLED IN A PARTICULAR ORIENTATION RELATIVE TO THE FORCES GENERATED BY THE BUCKING UNIT. ALWAYS INSPECT LOAD CELLS FOR ANY FORCE DIRECTIONAL INDICATOR ARROW AND INSTALL ACCORDINGLY TO AVOID INCORRECT TORQUE READINGS OR EQUIPMENT DAMAGE.

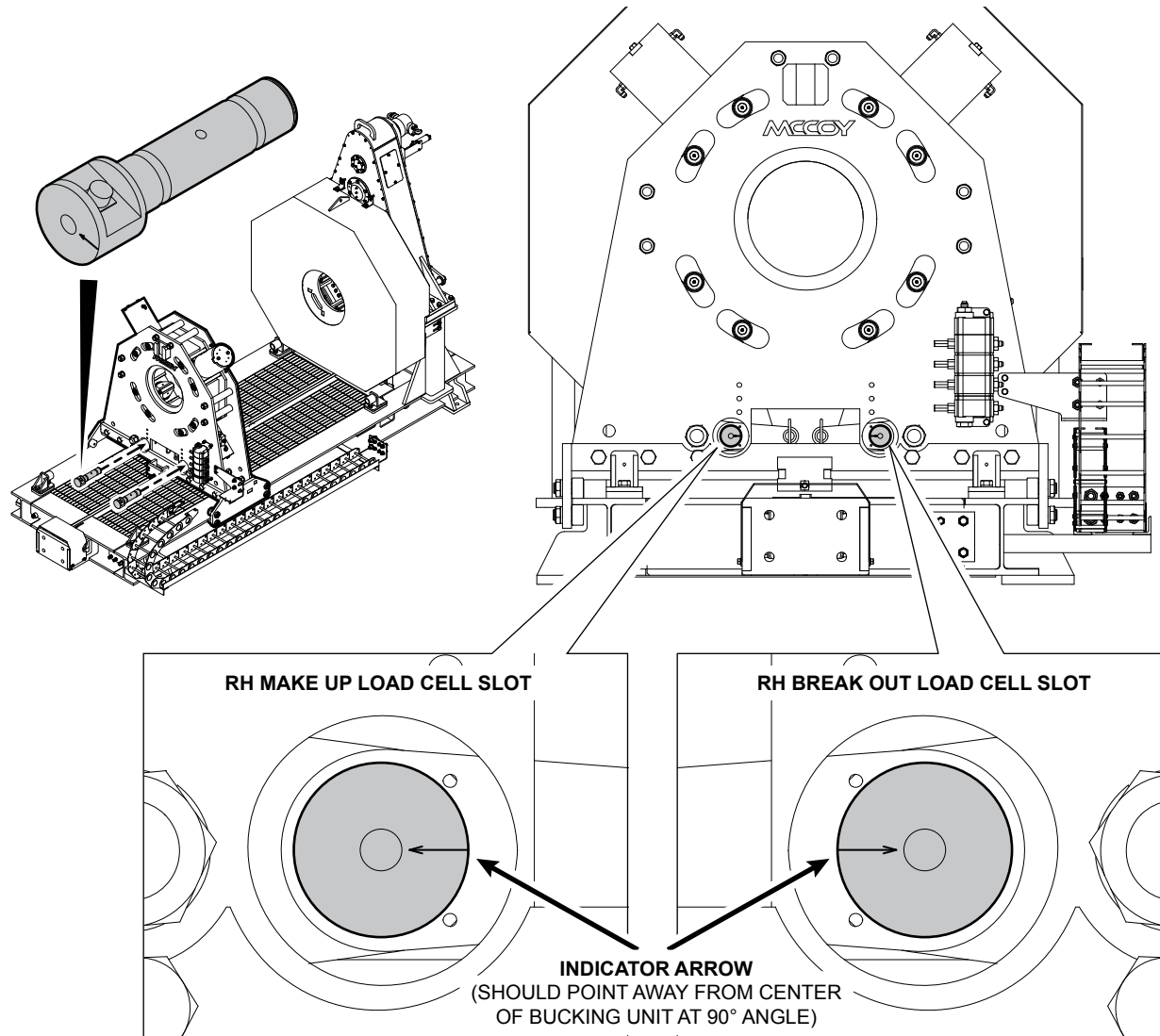

Illustration 3.4.2: Pin Style Load Cell Installation

! CAUTION

LOAD CELL CABLES MUST BE ARRANGED IN SUCH A WAY TO COMPENSATE FOR BACKUP TRAVEL DISTANCE AND THE POSSIBILITY OF CABLES BECOMING SNAGGED OR PINCHED ON MOVING COMPONENTS. CABLES SHOULD BE ROUTED THROUGH HOSE TRAYS IF PRESENT.

3.4.4 Adjusting Clamp & Torque Pressure

The Clamp Pressure and Torque Pressure controls regulate pressure in the backup and tong respectively. These valves require occasional adjustment to compensate for wear of the jaw die inserts and for re-setting the pressures to factory specification when new die inserts are installed. Occasional lowering of pressure may be required for thin-walled pipe or tubing, or if the unit is being used in non-marking applications. Ideal pressure must be determined based on the parameters of the connection to be made up.

Use this procedure to check and adjust the clamp/torque pressure:

1. The assembly must be connected to an active hydraulic fluid power source to perform this procedure.
2. Use the Tailstock Clamp / Unclamp lever to fully extend the backup clamp cylinder (see Section 4 for hydraulic operating instructions). When the cylinder is fully extended, do not release the valve lever.
3. Backup clamping pressure is displayed on the Clamp Pressure gauge. Rotating the relief valve clockwise will increase the pressure, rotating the relief valve counter-clockwise will decrease the pressure.

NOTICE

PRESSURES CANNOT BE MONITORED WHEN THE VALVE LEVERS ARE IN THE NEUTRAL POSITION.

CAUTION

CLAMP/TORQUE PRESSURE MUST BE DETERMINED ON A PER-CONNECTION BASIS AND MUST TAKE INTO ACCOUNT THE REQUIREMENTS AND STRUCTURAL LIMITATIONS OF THE CONNECTION.

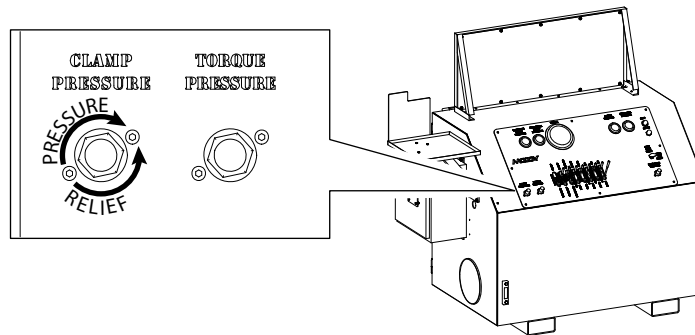

Illustration 3.4.1: Clamp & Torque Pressure Adjustment

Maximum Clamp/Torque pressure is the system pressure (as displayed on the system pressure indicator on the tong), or 3000 PSI (20.684 MPa), whichever is lower. Never exceed 3000 PSI (20.684 MPa).

WARNING

CLAMP/TORQUE PRESSURE MUST NEVER EXCEED 3000 PSI (20.684 MPa)

3.4.5 Installing a Turns Encoder

To install a turns encoder on the tong assembly, use the following procedure:

1. Locate the encoder mount location on the tong assembly of the tong.
2. Carefully cut the paint on the edges of the encoder mount cover plate, taking care to assure that paint does not flake off when removing the plate.
3. Remove the encoder mount cover plate.
4. Using an allen wrench, remove the encoder blade from the blade mount.
5. Align the flat of the encoder blade with the flat on the encoder. Install the encoder blade onto the encoder. Coat set screw with anti-seize compound. Using an allen wrench, tighten set screw and secure blade in place snugly.
6. Determine desired orientation for encoder and rotate the encoder shaft with attached encoder blade so that the blade aligns with the gear surface slot inside the encoder mount assembly.
7. Mount the encoder, assuring the encoder shaft with attached encoder blade fit properly into the gear surface slot.
8. Tighten mounting screws and attach encoder cable as necessary.

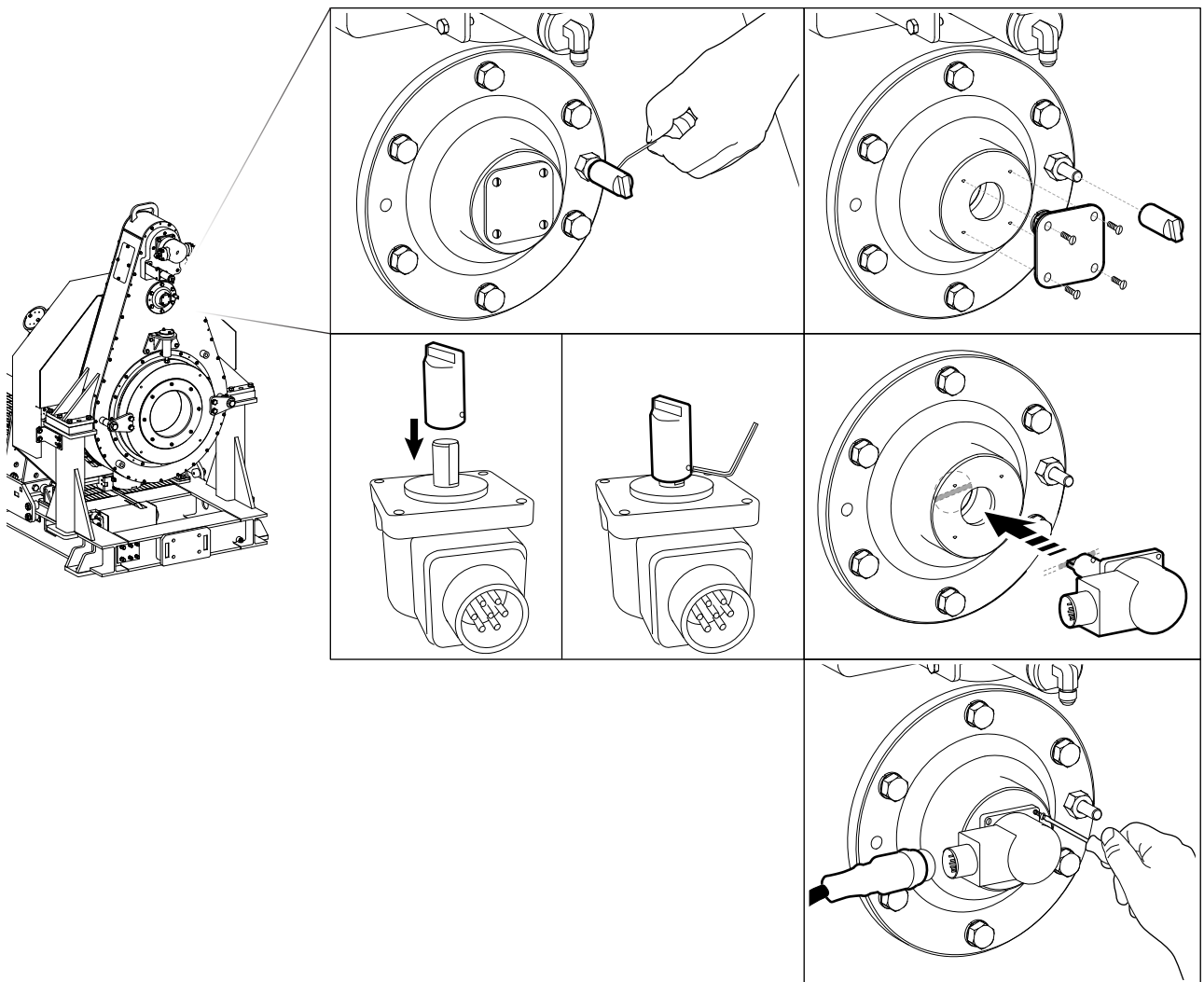

Illustration 3.4.2: Turns Encoder Installation



**This page intentionally
left blank**



SECTION 4: OPERATION



**This page intentionally
left blank**

4.0 OPERATOR TRAINING

McCoy Global recommends operator training, which typically consists of operation of the equipment under the supervision of a trained equipment operator until a satisfactory level of competence is achieved. Typical operator training should include:

- Introduction to and general description of equipment
- Technical specifications and performance data
- Operating instructions
- Control systems and interlocks
- Operating hazards
- Checks and inspections

4.1 OPERATOR SAFETY

McCoy recommends that a hazard assessment of the work area be performed by a designated safety representative before commencing operations. A designated safety representative is responsible for verifying that all operators have adequate equipment and safety training.

The area surrounding the equipment and the equipment itself must be free from clutter and debris. Tripping hazards, or protruding objects that may snag hydraulic hoses on the tong, backup, lift cylinder, or torque measurement system must be eliminated. Operating surface or drill floor must be kept free of slipping hazards like grease, oil, water, etc.

Adequate lighting of the work area is required. All warnings, labels, gauges, and signs must be clearly visible

Areas painted yellow are designated as hazardous areas, and contact with those areas must be avoided during operation. Always wear all personal protective equipment (PPE) specified by applicable HSE policies and follow all designated safety guidelines.

CAUTION

ALWAYS WEAR APPROVED PERSONAL PROTECTIVE EQUIPMENT (PPE) WHEN OPERATING HYDRAULICALLY-POWERED EQUIPMENT.

Ensure hydraulic power is deactivated and tong hydraulics are depressurized before disconnecting the main hydraulic lines. McCoy recommends depressurizing the hydraulic system (see page 5.4) before connecting or disconnecting quick-connect fittings.

WARNING

DEPRESSURIZE EQUIPMENT BEFORE DISCONNECTING MAIN HYDRAULIC LINES.

WARNING

NEVER STEP ON ANY PART OF THE SKID OR BEAMS WHILE THE EQUIPMENT IS ACTIVE. PERSONNEL SHOULD NEVER COME WITHIN CLOSE PROXIMITY TO ANY CLAMP CYLINDER WHILE THE EQUIPMENT IS ACTIVE.

CAUTION

RESTRICTED MOVEMENT OF ANY COMPONENT OF THE BUCKING UNIT DUE TO CLUTTER OR DEBRIS POSES A RISK TO PERSONNEL AND MAY CAUSE EQUIPMENT DAMAGE.

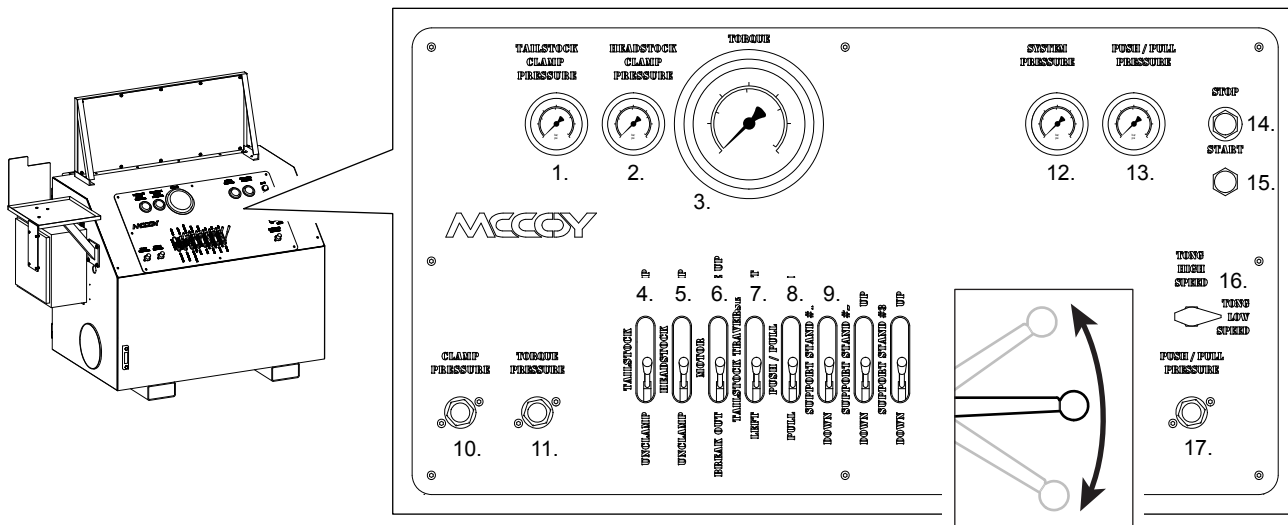

Illustration 4.2.1: Control Panel Functions & Readouts

NOTICE

THIS INFORMATION IS PROVIDED TO ILLUSTRATE FUNCTIONALITY OF THE BUCKING UNIT. FOR A MORE ACCURATE BREAKDOWN OF THE CONSOLE PAIRED WITH THE BUCKING UNIT, SEE THE SEPARATE CONTROL CONSOLE / POWER UNIT MANUAL PROVIDED.

4.2 CONTROL PANEL OPERATION GUIDE

1. TAILSTOCK CLAMP PRESSURE GAUGE

- Pressure gauge that displays the current hydraulic pressure of the backup clamp cylinders. Displays current pressure only when handle is actuated.

2. HEADSTOCK CLAMP PRESSURE GAUGE

- Pressure gauge that displays the current hydraulic pressure of the tong clamp cylinders. Displays current pressure only when handle is actuated.

3. TORQUE PRESSURE GAUGE

- Pressure gauge that displays current motor pressure

4. TAILSTOCK - CLAMP / UNCLAMP

- **Clamp** - extends and clamps the backup clamping cylinders to the pressure set by utilizing the Clamp Pressure valve
- **Unclamp** - retracts the backup clamping cylinders

5. HEADSTOCK - CLAMP / UNCLAMP

- **Clamp** - extends and clamps the backup clamping cylinders to the pressure set by utilizing the Clamp Pressure valve
- **Unclamp** - retracts the backup clamping cylinders

6. MOTOR - BREAK OUT / MAKE UP

- **Break Out** - rotates the tong vise assembly in a counter-clockwise direction to 'Break Out' a right handed threaded connection
- **Make Up** - rotates the tong vise assembly in a clockwise direction to 'Make Up' a right handed threaded connection

7. TAILSTOCK TRAVERSE - LEFT / RIGHT

- **Left** - moves the backup assembly left (towards the backup) horizontally along the bucking unit skid
- **Right** - moves the backup assembly right (towards the tong) horizontally along the bucking unit skid

8. PUSH / PULL - PULL / PUSH (OPTIONAL)

- **Push** - extends the push/pull cylinder to push tubulars horizontally through the bucking unit
- **Pull** - retracts the push/pull cylinder to pull tubulars horizontally through the bucking unit

9. SUPPORT STAND - UP / DOWN (OPTIONAL)

- **Up** - extends the support stand hydraulic cylinder vertically up
- **Down** - retracts the support stand hydraulic cylinder vertically down

10. CLAMP PRESSURE

- **Rotate Clockwise** - increases hydraulic clamping pressure in the backup and tong clamp cylinders
- **Rotate Counter-Clockwise** - lowers hydraulic clamping pressure in the backup and tong clamp cylinders

11. TORQUE PRESSURE

- **Rotate Clockwise** - increases hydraulic pressure to the motor for torque
- **Rotate Counter-Clockwise** - lowers hydraulic pressure to the motor for torque

12. SYSTEM PRESSURE GAUGE

- Pressure gauge that displays the current hydraulic pressure of the valve on the hydraulic inlet

13. PUSH/PULL PRESSURE GAUGE (OPTIONAL)

- Pressure gauge that displays the current hydraulic pressure of the push/pull cylinder

14. STOP BUTTON

- When pressed, shuts down the internal power unit. Button must be pulled up in order for the unit to function.

15. START BUTTON

- Starts the internal power unit when pressed. Button will not function unless the stop button is pulled to the ready position.

16. TONG HIGH / LOW SPEED SWITCH

- **High Speed** - switching to High Speed mode will set the tong gear train to run in a high speed/low torque mode
- **Low Speed** - switching to Low Speed mode will set the tong gear train to run in a low speed/high torque mode

 **WARNING**

NEVER ATTEMPT TO SHIFT SPEEDS WHILE ANY PART OF THE EQUIPMENT IS IN MOTION.

17. PUSH / PULL PRESSURE (OPTIONAL)

- **Rotate Clockwise** - increases hydraulic clamping pressure in the push/pull cylinder
- **Rotate Counter-Clockwise** - lowers hydraulic clamping pressure in the push/pull cylinder

4.3 PRE-OPERATIONAL CHECKS

McCoy recommends that the following tests and inspections be performed prior to releasing the unit to an operational environment:

1. Secure all installed extension beam mounted accessories in place by utilizing the locking pin mechanisms that prevent horizontal movement along the beam. Do not manually adjust accessories while the equipment is energized.
2. Connect the unit to a hydraulic power source in a controlled environment. Ensure the power unit's operating parameters are within the specifications as identified in Section 2. Ensure the hydraulic connections from the power unit are properly and securely made up (see Section 3). Do not neglect to connect the motor drain line.
3. Start the power unit as specified by the power unit operator's manual. Inspect all pressure and return line hose connections to ensure correct and secure installation. A restriction in the pressure supply hose will result in high pressure within the power unit hydraulic system, which will activate the hydraulic governor and increase the motor speed to as high as maximum RPM. A restriction in the return line will result in high pressure within the power unit and the tong hydraulic system, causing motor speeds as high as maximum RPM, and possible failure of the motor seal.
4. Allow hydraulic system to warm by circulating fluid for 10 minutes. Ensure circulating pressure does not exceed 200 psi.
5. Inspect all hydraulic hoses and connections on the equipment. Immediately correct any hydraulic fluid leaks.
6. Inspect all gauges. Replace leaking or cracked gauges, or any gauge not registering a reading.
7. Confirm all hydraulic hoses are secured and not in contact with any rotating component.
8. Verify the stop button on the control console is operational and shuts off power to the power unit.

4.4 GENERAL OPERATIONAL COMMENTS

When making-up integral (shouldered) joints, it is essential to make up the last turn of the threads with the motors running at the lowest speed at full motor displacement. This reduces the tendency of an instant stop or a sudden increase in torque, which induces extremely high stresses on the gear train.

4.5 INITIAL STARTUP

1. Remove shipping bolts/brackets/etc. from the unit (See page 3.4).
2. Install control console (See page 3.12) and electrical service to console starter box (see power unit / control console manual for power requirements).
3. If unit is to be started up by McCoy factory technicians, STOP installation procedures now and notify McCoy that the unit is now ready for McCoy technicians to perform startup services. If owner is performing installation and startup, continue to next step.
4. Ensure all control valve levers are in neutral position.
5. If the unit is equipped with a PLC, consult the PLC manual for any startup instructions.
6. Consult applicable power unit manual for power unit startup instructions.
7. Start hydraulic power unit using start button on console and allow hydraulic power unit to run for 10 minutes to purge air from primary circuits while monitoring for any leakage.
8. Switch the Tong Speed High / Low Switch to the 'Low' position on the control console.
9. Slowly shift the Motor Make Up / Break Out lever from neutral to the 'Make Up' position and allow the unit to rotate for one (1) minute.
10. Shift Motor Make Up / Break Out lever to the 'Break Out' position and allow the unit to rotate for one (1) minute.
11. Wait for rotating elements to come to a complete stop, then switch the Tong Speed High / Low Switch to the 'High' position.
12. Shift Motor Make Up / Break Out lever into 'Break Out' position for one (1) minute.
13. Shift Motor Make Up / Break Out lever into 'Make Up' position and allow unit to rotate for one (1) minute.
14. Release Motor Make Up / Break Out lever and assure that it returns to the neutral position.

4.6 PIPE INSTALLATION

1. Ensure clamp cylinders are set to their fully open position by manipulating the Clamp / Unclamp levers into the 'Unclamp' position.
2. Adjust the spacing between the tong and backup using the Tailstock Traverse lever to accommodate the joint being torqued.
3. Using pipe handling systems or a crane, carefully install the pipe in the bucking unit in a level position, assuring that the tubular is placed as close to the unit centerline as possible.
4. Actuate the Headstock Clamp / Unclamp lever to the 'Clamp' position. Adjust to desired pressure.

CAUTION

SET CLAMPING PRESSURE WITHIN THE RANGE DETERMINED BY THE PIPE SIZE AND WALL THICKNESS. SEE SECTION 3 FOR PRESSURE SETTING INSTRUCTIONS.

5. After reaching desired pressure, allow the Headstock Clamp / Unclamp lever to return to its neutral position.
6. Visually confirm proper backup position in relation to tubular before clamping onto tubular. **NOTE: If adequate space is not left to accommodate thread travel, the backup will contact the tong, potentially damaging the equipment or tubular connection.**

CAUTION

IF ADEQUATE SPACE IS NOT LEFT TO ACCOMMODATE THREAD TRAVEL, THE BACKUP WILL CONTACT THE TONG, POTENTIALLY DAMAGING THE EQUIPMENT OR TUBULAR CONNECTION.

7. Clamp the backup onto pipe by actuating the Tailstock Clamp / Unclamp lever to the 'Clamp' position. Adjust to desired pressure.
8. After reaching desired pressure, allow the Tailstock Clamp / Unclamp lever to return to its neutral position.

NOTICE

PRESSURES CANNOT BE MONITORED WHEN THE VALVE LEVERS ARE IN THE NEUTRAL POSITION.

4.6 PIPE INSTALLATION (CONTINUED):

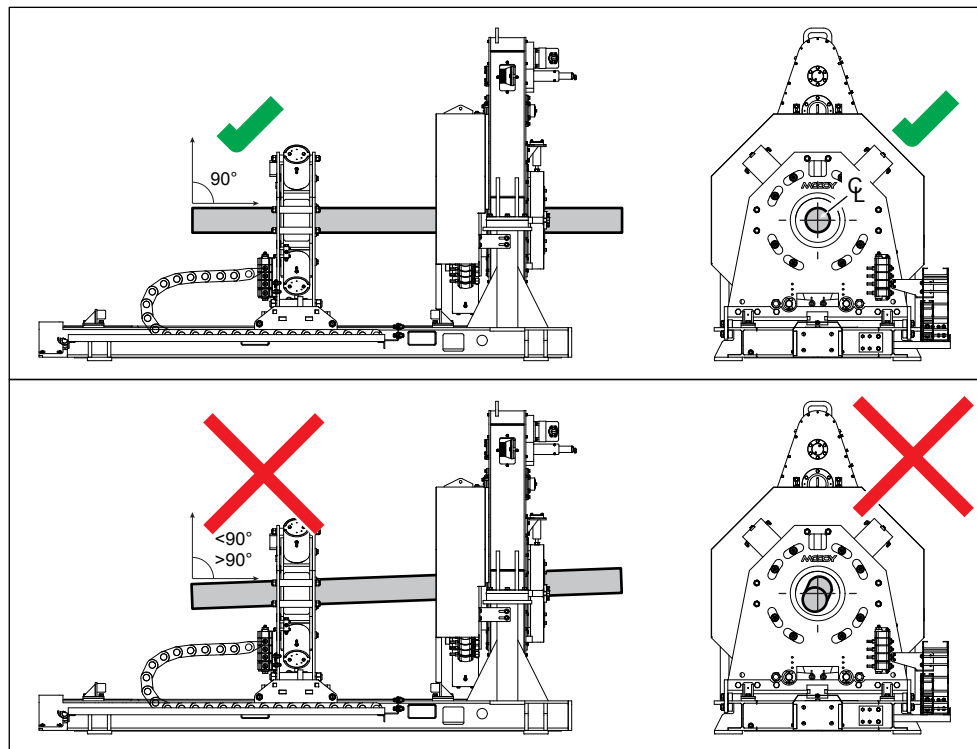

Illustration 4.6.1: Level Pipe Installation

! CAUTION

ACTIVATING THE JAWS OR APPLYING TORQUE WITH IMPROPERLY CLOSED JAWS COULD RESULT IN MECHANICAL DAMAGE OR INJURY TO NEARBY PERSONNEL. THIS CAN OCCUR IF THE PIPE IS INCORRECTLY POSITIONED WITHIN THE BUCKING UNIT, OR IF THE IMPROPER COMBINATION OF DIES AND PIPE DIAMETERS ARE USED.

4.7 MAKING AND BREAKING CONNECTIONS

Set up and prepare your equipment for operation. Refer to Section 3.

The bucking unit should be properly leveled, connected to a hydraulic power source, have all load cells installed, and otherwise ready to make or break connections at this point.

1. Ensure hydraulic power supply to the unit is energized.
2. Start the motor.
3. Move Tong Make Up / Break Out lever in either direction until the power tong completes a rotation.
4. Hold Tailstock Clamp / Unclamp lever in the 'Unclamp' position and adjust Clamp Pressure Control until system pressure reads 1,000 psi. Cycle all levers fully several times to completely purge all air from the system.

! CAUTION

SET CLAMPING PRESSURE WITHIN THE RANGE DETERMINED BY THE PIPE SIZE AND WALL THICKNESS. SEE SECTION 3 FOR PRESSURE SETTING INSTRUCTIONS.

5. Position tubular connection near the center of the tong, then shift the Tailstock Clamp / Unclamp lever to the 'Clamp' position. Tailstock Clamp / Unclamp control lever must be held in the 'Clamp' position while the tubular is in the unit.

4.7 MAKING AND BREAKING CONNECTIONS (CONTINUED):

6. Position backup as close as possible to tong, allowing required space for thread travel.
7. Shift Headstock Clamp / Unclamp lever into the 'Clamp' position.
8. Using the Motor Make Up / Break Out control lever, apply make up or break out torque.

 **CAUTION**

IF ADEQUATE SPACE IS NOT LEFT TO ACCOMMODATE THREAD TRAVEL, THE BACKUP WILL CONTACT THE TONG, POTENTIALLY DAMAGING THE EQUIPMENT OR TUBULAR CONNECTION. SUCH DAMAGE IS NOT COVERED BY THE WARRANTY. REFER TO THE MINIMUM CENTER-TO-CENTER DIE DISTANCE OUTLINED IN SECTION 2 OF THIS MANUAL.

 **CAUTION**

NEVER ATTEMPT TO PULL APART 'STUCK' CONNECTIONS BY ATTACHING ANY TYPE OUTSIDE EQUIPMENT TO THE BACKUP ASSEMBLY IN AN ATTEMPT TO IMPART ADDITIONAL LATERAL FORCE ON IT BEYOND THE CAPABILITY OF THE TRAVERSE MOTOR.

4.8 EXTREME COLD WEATHER OPERATION CONSIDERATIONS

1. Consult the power unit engine operator's manual for all cold weather operating procedures and precautions.
2. Select gear and bearing lubricants that are compatible with expected climatic conditions.
3. Select hydraulic fluid that is compatible with expected climatic conditions.
4. Allow hydraulic fluid to circulate for approximately 20 minutes after starting the power unit, prior to activating the bypass valve to allow fluid to circulate to tong. If the power unit is equipped with an oil temperature gauge, ensure that the fluid has reached operating temperature as specified by hydraulic fluid data sheet.
5. Allow for adequate drying of moisture (prior to lubricating) when cleaning tong parts in cold weather.



**This page intentionally
left blank**



SECTION 5: MAINTENANCE



**This page intentionally
left blank**

McCoy Global recognizes that minor on-site repairs and modifications are required to maintain peak operating condition of your equipment, or to match your equipment with the operating environment. Examples of minor repairs are:

- Replacement of damaged hydraulic hoses and fittings
- Replacement of malfunctioning pressure gauges and valves
- Replacement of fasteners

Any replaced component must be an identical component supplied by McCoy Global. Replaced fasteners must be Grade 8 or equivalent, unless otherwise specified by McCoy. All repairs must be performed by authorized, skilled personnel. Any attempt to make unauthorized repairs to equipment beyond the minor repairs described above exposes personnel to potential hazards and may cause catastrophic equipment failure. Contact McCoy if any question about the nature of repairs arises.



DANGER

MAKING UNAUTHORIZED REPAIRS TO YOUR EQUIPMENT EXPOSES PERSONNEL TO POTENTIAL HAZARDS AND MAY CAUSE CATASTROPHIC EQUIPMENT FAILURE.

5.0 GENERAL MAINTENANCE SAFETY PRACTICES

The practices identified here are intended as a guideline. All personnel are responsible for performing their tasks in a manner that ensures worker, equipment, and environmental safety, and may require taking additional steps that are not identified in this section.

Equipment maintenance shall be performed only by designated qualified maintenance personnel. Wear appropriate PPE and follow all of designated safety guidelines. Do not begin a maintenance task without the proper tools or materials on hand, or the proper drawings and documentation necessary.

Schedule planned maintenance with operators to avoid conflicts, unnecessary downtime, and the danger of accidental equipment activation. Notify operations when maintenance procedures are complete and equipment functionality is restored.

Isolate the location of the maintenance under way to prevent unaware personnel from inadvertently exposing themselves to a hazard. Use tape, rope, or signage to clearly indicate an "off-limits" area.

Replacement of large, heavy individual parts and/or heavy structural components must be performed using an approved lifting device of sufficient lifting capacity. Use care when attaching the lifting device, and safeguard area to avoid endangering personnel or equipment.

All spare parts must meet or exceed OEM specifications in order to maintain equipment integrity, especially protective equipment

Ensure your equipment is isolated from hydraulic power before commencing maintenance operations.



WARNING

DO NOT PERFORM MAINTENANCE UNTIL TUBULAR CONNECTION EQUIPMENT HAS BEEN COMPLETELY ISOLATED FROM HYDRAULIC POWER

Your equipment uses materials that may be harmful to the environment if improperly disposed of (hydraulic fluid, grease, etc.). Dispose of all materials according to your company's proscribed environmental protection regulations.

5.1 CLEANING

Clean equipment thoroughly with a petroleum-based cleaning agent after each job, prior to storage. McCoy Global recommends that the motor and valve assembly be periodically removed, along with the top tong plate, so that guides, rollers and gears can be properly cleaned. Ensure that cleaning solvents and chemicals are captured to prevent environmental contamination, and dispose of all materials according to environmental protection regulations.

5.2 PREVENTIVE MAINTENANCE PRACTICES

Regular maintenance programs are necessary, and must be established to assure safe, dependable operation and to avoid costly breakdown maintenance. The following maintenance procedures provides information required to properly maintain the equipment. The equipment may require more, or less maintenance depending upon the frequency of use and the field conditions under which your equipment operates. These maintenance procedures are designed for equipment operating at 10°C to 35°C ambient temperature for 10 hours per day. McCoy recommends that the inspection and maintenance procedures in this section be performed as recommended in the maintenance checklists.

Manufacturers of purchased components included with the equipment (for example: motors, valves, etc.) may specify maintenance tasks and intervals over and above what McCoy recommends as part of their recommended procedures. All OEM maintenance instructions should be observed.

McCoy Global recommends tracking all maintenance activity, including the lubrication schedule and replacement of hydraulic hoses. This may be as simple as keeping a paper log, or using a software-based maintenance tracking utility. A maintenance log is a valuable tool that can be used for easily retrieving maintenance history or identifying trends that require correction.

5.3 HYDRAULIC SYSTEM MAINTENANCE

Poor hydraulic fluid maintenance is a leading cause of hydraulic equipment failure. Contaminants are introduced to the hydraulic system through several sources including dirty hydraulic connections, dirty hydraulic cylinder rods, and through the wear of internal components. Failure to remove entrained contaminants through the use of a maintained filtration system will contribute to rapid wear of system components. McCoy recommends filtering to ISO 4406:1999 standards.

Premature fouling of particulate filters within the prime mover or ancillary hydraulic power unit indicates a high level of contaminants, and requires immediate hydraulic fluid laboratory analysis to identify the contaminants. High levels of wear metals in the fluid may be symptomatic of impending failure of a component in a hydraulic system. Early identification of the potential failure enables the user to schedule preventive repairs, preventing costly breakdown maintenance.

Fluid that has been repeatedly and consistently overheated will provide much poorer response and overall performance than fluid in a temperature-managed hydraulic system. McCoy recommends the use of hydraulic heaters and/or coolers to maintain the fluid temperature within the operating temperature range specified in Section 2. Maintaining adequate fluid level in the hydraulic reservoir helps dissipate heat in the hydraulic system. Fluid repeatedly heated to high temperatures (above 80°C) is subject to rapid depletion of the additives that prevent oxidation and water emulsification, leading to the build-up of sludge, gum, and varnish. These contaminants will build up on internal surfaces of the components of the hydraulic system causing “sticky” operation or clogging orifices and small passages. Water entrained in the fluid will react with components in the hydraulic system to produce rust and increase the rate of oxidation of the fluid.

Regularly schedule hydraulic fluid analysis as part of a preventive maintenance routine. Test particulate content using a portable fluid analysis kit, and compare the fluid sample to new hydraulic fluid. Fluid that is discolored or has a foul odor should be sent to a qualified laboratory for detailed analysis. Hydraulic fluid that is no longer capable of operating within the parameters specified by this manual must be replaced, and the hydraulic system flushed.

Fluid that is unused for a long period of time should be tested before circulating through the hydraulic system. Hydraulic systems operated in environments experiencing extreme temperature variances are susceptible to condensation within in the oil reservoir. Over a period of time the condensation will accumulate in the bottom of the reservoir, which should be drawn off at six month intervals, or as required.

5.4 HYDRAULIC SYSTEM DEPRESSURIZATION

McCoy Global recommends that the hydraulic system be depressurized prior to maintenance on any hydraulic component. Perform the following steps to ensure the dangers posed by hydraulic fluid under pressure are minimized.

CAUTION

ENSURE ADEQUATE CONTAINMENT IS IN PLACE TO PREVENT ENVIRONMENTAL CONTAMINATION FROM RESIDUAL HYDRAULIC FLUID

1. Fully unclamp cylinders on both the tong and backup.
2. De-energize the power unit.
3. Repeatedly actuate motor control valve lever IN BOTH DIRECTIONS to dissipate any residual pressure in the valve and motor.
4. Remove the hydraulic SUPPLY line from the equipment.
5. Repeatedly actuate the remaining control valve levers IN BOTH DIRECTIONS to dissipate any residual pressure in the remainder of the hydraulic control system.

5.4 HYDRAULIC SYSTEM DEPRESSURIZATION (CONTINUED):

6. Disconnect the hydraulic RETURN line from the equipment, then disconnect remaining hoses.

 **WARNING**

HYDRAULIC PRESSURES AS HIGH AS OPERATING PRESSURE MAY REMAIN TRAPPED IN SMALL AREAS OF THE EQUIPMENT. ENSURE ALL MAINTENANCE IS CARRIED OUT BY A QUALIFIED SERVICE TECHNICIAN, AND THAT ADEQUATE PERSONAL PROTECTIVE EQUIPMENT IS USED TO GUARD AGAINST PRESSURE INJURIES

5.5 LUBRICATION INSTRUCTIONS

See page 2.9 for lubrication specifications. Ensure selected grease remains within its viscosity range at expected operating temperatures.

Periodically remove the access panels on the tong assembly and apply grease generously to the clutch, drive gears, shifting shaft and drive chain. Coat the jaw fasteners with a liberal amount of anti-seize compound when installing new jaw die kits.

McCoy recommends lubricating your equipment before beginning each shift, and immediately following operation prior to storage. The Lubrication Diagrams in this section identify all necessary lubrication points.

 **DANGER**

DEACTIVATE, DISCONNECT, AND LOCK OUT HYDRAULIC POWER BEFORE PROCEEDING

5.5 LUBRICATION INSTRUCTIONS (CONTINUED):

5.5.1 Tong Grease Diagram

| Item No. | Lubrication Location | Min. Lubrication Amount (Each Location) | Number of Locations |
|----------|---------------------------------|---|---------------------|
| 1 | Clutch Gear Assembly | 2 shots | 2 |
| 2 | Pinion Sprocket Assembly | 3 shots | 3 |
| 3 | Shifting Shaft / Shaft Bushings | grease as required | 1 |
| 4 | Drive Chain | grease as required | 1 |

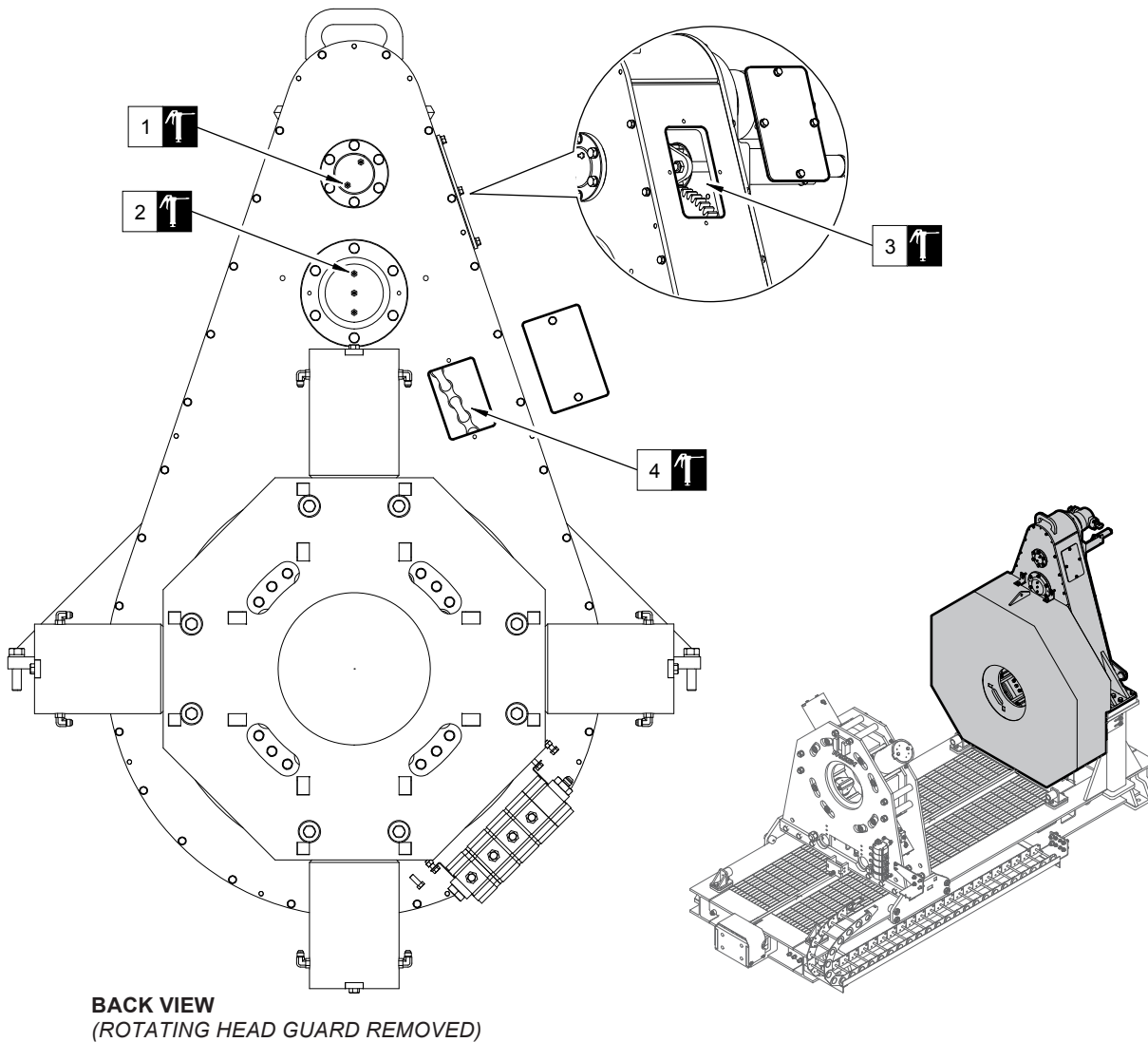

Illustration 5.5.1: Tong Grease Diagram

5.5 LUBRICATION INSTRUCTIONS (CONTINUED):

5.5.2 Backup Grease Diagram

| Item No. | Lubrication Location | Min. Lubrication Amount (Each Location) | Number of Locations |
|----------|--------------------------------|---|---------------------|
| 1 | Cam Follower Assembly | 3 shots | 8 |
| 2 | Cam Follower Assembly | 3 shots | 8 |
| 3 | Traverse Cam Follower Assembly | 3 shots | 8 |

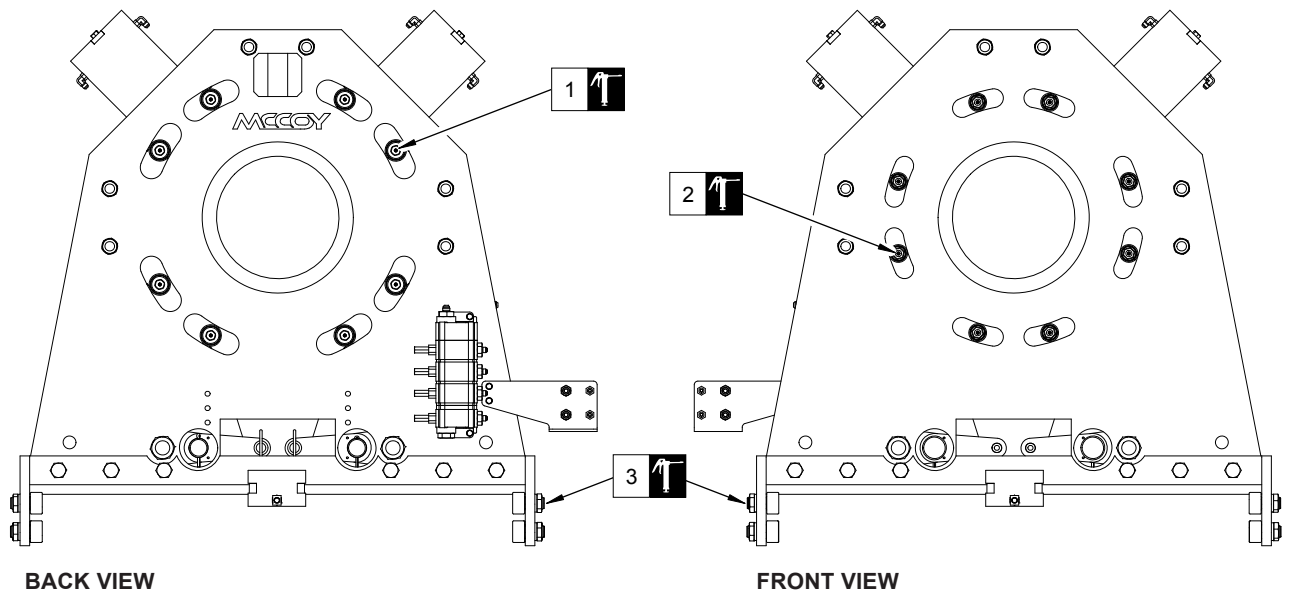

Illustration 5.5.2: Backup Grease Diagram

5.5 LUBRICATION INSTRUCTIONS (CONTINUED):

5.5.3 Skid Grease Diagram

| Item No. | Lubrication Location | Min. Lubrication Amount (Each Location) | Number of Locations |
|----------|----------------------|---|---------------------|
| 1 | Bearing Assembly | 3 shots | 4 |
| 2 | Traverse Chain | grease as required | 1 |

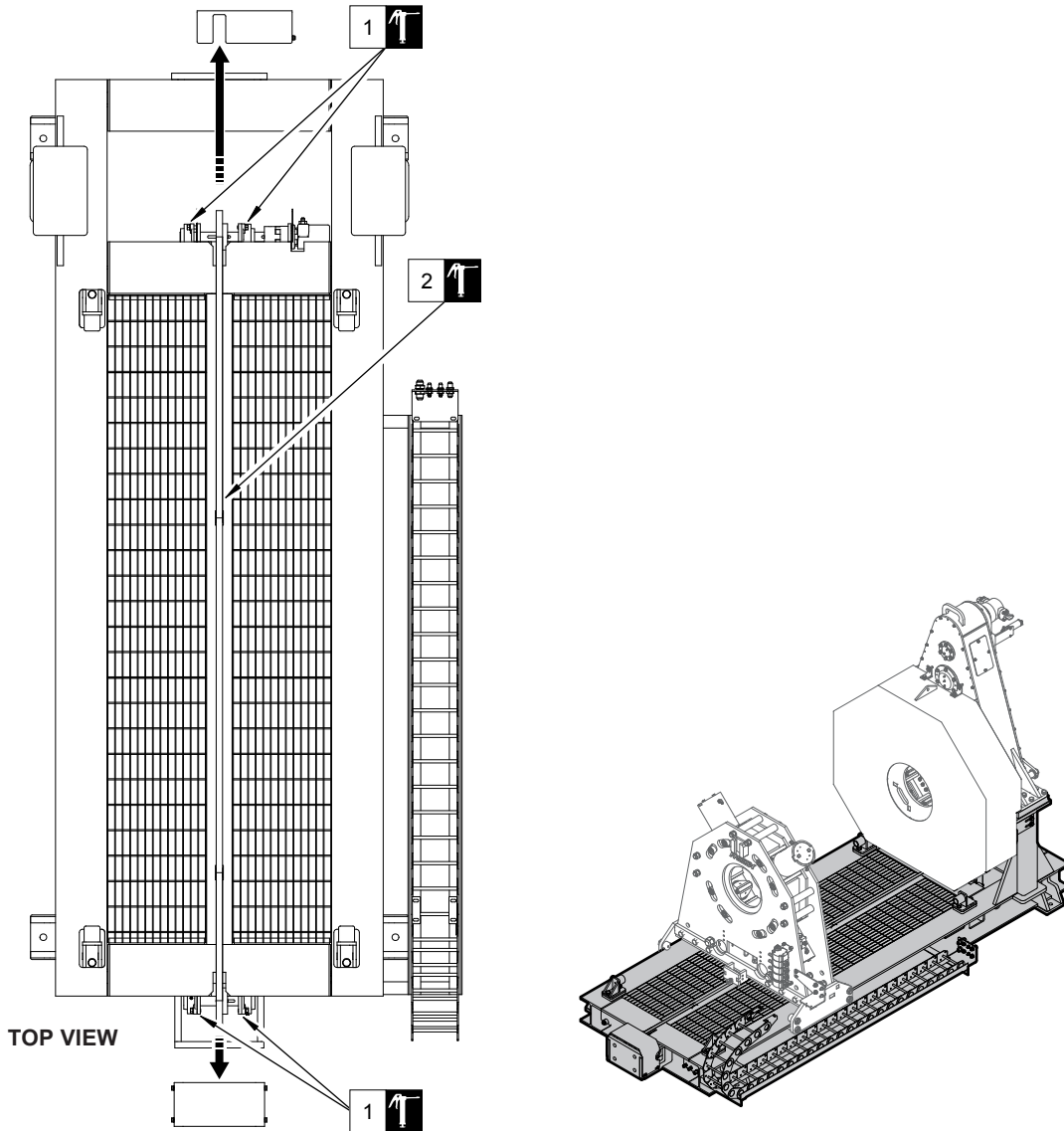

Illustration 5.5.3: Skid Grease Diagram

5.6 RECOMMENDED PERIODIC INSPECTIONS**5.6.1 Load Cell**

Installed load cells and all associated cables should be regularly examined for correct installation (see page 3.13), cleanliness, and for signs of visible damage. Damaged load cells are not user serviceable.

5.6.2 Hydraulic Hoses

All hydraulic hoses and hydraulic swivels should be routinely inspected for signs of visible damage or leaking. Assure all connections are fully made up. Leaking hoses or connections must be repaired or replaced prior to returning the equipment to service.

5.6.3 Clamp Cylinders

All hydraulic cylinders should be routinely inspected for signs of visible damage or leaking. Damaged cylinders must be repaired or replaced. Cylinder rods and the surface area surrounding them should be kept clean and free from debris to prevent damage and possible hydraulic oil contamination.

5.7 ASSEMBLY PRACTICES

NOTE ON INSTALLATION PRACTICES: Ensure all bearings are liberally greased before installing over a shaft or into gears or bearing caps. Also ensure all metal-to-metal contact in the gear train is adequately greased. **Please refer to the relevant exploded diagrams in Section 7 when assembling components.**

 **WARNING**

REPLACEMENT FASTENER (BOLTS, NUTS, CAP SCREWS, MACHINE SCREWS, ETC.) USED DURING MAINTENANCE OR OVERHAUL MUST BE GRADE 8 OR EQUIVALENT UNLESS OTHERWISE SPECIFIED.

| TIGHTENING TORQUE GUIDE (DRY) | | | | | | | |
|-------------------------------|------------|---------------|---------------|------------------------------|------------|---------------|---------------|
| SAE GRADE 8 - FINE THREAD | | | | SAE GRADE 8 - COARSE THREAD | | | |
| SIZE | CLAMP LOAD | PLAIN | PLATED | SIZE | CLAMP LOAD | PLAIN | PLATED |
| ¼ - 28 (.250) | 3,263 | 14 ft. lbs. | 10 ft. lbs. | ¼ - 20 (.250) | 2,850 | 12 ft. lbs. | 9 ft. lbs. |
| ⅝ ₁₆ - 24 (.3125) | 5,113 | 27 ft. lbs. | 20 ft. lbs. | ⅝ ₁₆ - 18 (.3125) | 4,725 | 25 ft. lbs. | 18 ft. lbs. |
| ⅜ - 24 (.375) | 7,875 | 49 ft. lbs. | 37 ft. lbs. | ⅜ - 16 (.375) | 6,975 | 44 ft. lbs. | 33 ft. lbs. |
| 7 ₁₆ - 20 (.4375) | 10,650 | 78 ft. lbs. | 58 ft. lbs. | 7 ₁₆ - 14 (.4375) | 9,600 | 70 ft. lbs. | 52 ft. lbs. |
| ½ - 20 (.500) | 14,400 | 120 ft. lbs. | 90 ft. lbs. | ½ - 13 (.500) | 12,750 | 106 ft. lbs. | 80 ft. lbs. |
| 9 ₁₆ - 18 (.5625) | 18,300 | 172 ft. lbs. | 129 ft. lbs. | 9 ₁₆ - 12 (.5625) | 16,350 | 153 ft. lbs. | 115 ft. lbs. |
| ⅝ - 18 (.625) | 23,025 | 240 ft. lbs. | 180 ft. lbs. | ⅝ - 11 (.625) | 20,325 | 212 ft. lbs. | 159 ft. lbs. |
| ¾ - 16 (.750) | 33,600 | 420 ft. lbs. | 315 ft. lbs. | ¾ - 10 (.750) | 30,075 | 376 ft. lbs. | 282 ft. lbs. |
| 7 ₈ - 14 (.875) | 45,825 | 668 ft. lbs. | 501 ft. lbs. | 7 ₈ - 9 (.875) | 41,550 | 606 ft. lbs. | 454 ft. lbs. |
| 1 - 12 (1.000) | 59,700 | 995 ft. lbs. | 746 ft. lbs. | 1 - 8 (1.000) | 54,525 | 909 ft. lbs. | 682 ft. lbs. |
| 1 - 14 (1.000) | 61,125 | 1019 ft. lbs. | 764 ft. lbs. | 1-⅛ - 7 (1.125) | 68,700 | 1288 ft. lbs. | 966 ft. lbs. |
| 1-⅛ - 12 (1.125) | 77,025 | 1444 ft. lbs. | 1083 ft. lbs. | 1-¼ - 7 (1.125) | 87,225 | 1817 ft. lbs. | 1363 ft. lbs. |
| 1-¼ - 12 (1.125) | 96,600 | 2012 ft. lbs. | 1509 ft. lbs. | 1-⅜ - 6 (1.375) | 103,950 | 2382 ft. lbs. | 1787 ft. lbs. |
| 1-⅜ - 12 (1.375) | 118,350 | 2712 ft. lbs. | 2034 ft. lbs. | 1-½ - 6 (1.500) | 126,450 | 3161 ft. lbs. | 2371 ft. lbs. |
| 1-½ - 12 (1.500) | 142,275 | 3557 ft. lbs. | 2668 ft. lbs. | | | | |

NOTICE**IMPORTANT ASSEMBLY INFORMATION**

DO NOT TORQUE NYLOCK NUTS. NYLOCK NUTS ARE NOT USED FOR CLAMPING PURPOSES AND SHOULD ONLY BE TIGHTENED UNTIL METAL-TO-METAL CONTACT IS MADE AND VERTICAL MOTION IS ELIMINATED. OVER-TIGHTENING WILL RESULT IN PREMATURE BUSHING FAILURE AND WILL INHIBIT ROTATION, AND MAY IMPART EXCESS STRESS ON ROTATING COMPONENTS.

NYLOCK NUTS ARE A ONE-TIME USE ITEM AND MUST BE DISCARDED & REPLACED AFTER USE.

5.8 DAILY INSPECTION & MAINTENANCE CHECKLIST

McCoy recommends that the following inspection and maintenance procedures be performed before each use, and at least once per day when the tong is in steady use, in the order in which they are listed.

 **WARNING**

DO NOT PERFORM ANY FURTHER ACTIONS OR MAINTENANCE WHILE THE TONG IS CONNECTED TO ANY HYDRAULIC POWER SUPPLY. MCCOY RECOMMENDS THAT ALL HYDRAULIC LINES ARE FULLY DISCONNECTED, AND RESIDUAL HYDRAULIC PRESSURE IS BLED OFF. ENSURE ADEQUATE CONTAINMENT IS IN PLACE TO PREVENT ENVIRONMENTAL CONTAMINATION FROM RESIDUAL HYDRAULIC FLUID.

1. **DEPRESSURIZE HYDRAULIC SYSTEM IN PREPARATION FOR MAINTENANCE.**
Complete Depressurization Procedure on page 5.4.

 **WARNING**

HYDRAULIC PRESSURES AS HIGH AS OPERATING PRESSURE MAY REMAIN TRAPPED IN SMALL AREAS OF THE EQUIPMENT. ENSURE ALL MAINTENANCE IS CARRIED OUT BY A QUALIFIED SERVICE TECHNICIAN, AND THAT ADEQUATE PERSONAL PROTECTIVE EQUIPMENT IS USED TO GUARD AGAINST PRESSURE INJURIES

2. Remove the majority of dirt and grease build-up from the tong, backup, and skid assemblies using a hose with spray nozzle, or a pressure washer set to the "low pressure" mode. Ensure adequate containment is in place to prevent environmental contamination from residual hydraulic fluid and dirty grease.
3. Perform a visual inspection of the gear train through the access plate on the tong assembly. If gear damage or chips of metal are seen, the tong should be removed from service and overhauled to avoid further damage.
4. Perform a visual inspection of the backup. Premature wear where there are moving parts (bare metal where there used to be paint, and metal shavings in the grease are good indicators) may show where a component needs to be adjusted, or if necessary, replaced.
5. Perform a visual inspection of all fasteners and protruding body pieces. Tighten or replace loose or missing fasteners. McCoy recommends that damaged or missing body parts be repaired or replaced as soon as possible.
6. Inspect the jaws and dies on the tong and backup. Ensure dies are secure in the jaw. Replace worn dies if necessary. Ensure jaw retainer bolts are set to correct torque value shown on page 3.11.
7. Perform a visual inspection of all lifting points. If visible damage is seen, replace damaged part(s) before placing equipment into service.
8. Inspect tong for signs of premature wear, or moving parts that are rubbing (bare metal where there used to be paint is a good indication of wear).
9. Perform a visual inspection of all hydraulic lines. Replace flexible lines if they appear to be cracked, fatigued, or have visible signs of wear from contact with a rigid object.
10. Perform a complete greasing of the equipment. Refer to Maintenance Section of the technical manual for grease diagrams.
11. Ensure main supply and return connections to the tong are fully made up. Reconnect the remainder of the hydraulic lines and the electrical lines.

 **WARNING**

FAILURE TO ENSURE THAT THE SELF-SEALING SUPPLY AND RETURN LINES ARE FULLY MADE UP MAY RESULT IN CATASTROPHIC EQUIPMENT FAILURE.

5.8 DAILY INSPECTION & MAINTENANCE CHECKLIST (CONTINUED):

12. Refer to control console / power unit manual for startup procedures and start power unit.
13. Ensure that supply pressure is at or above the equipment's specified operating pressure, and that the return pressure is less than 350 psi.
14. Perform a visual inspection of pressurized hydraulic lines. Document and correct any hydraulic fluid leaks.
15. Perform a full functional test of the equipment. Report and correct any hydraulic leaks from the hydraulic valve bank, or from any hydraulic cylinder.
16. Perform a visual inspection of the load cell. Replace any cracked, broken, or distorted components.

5.9 MONTHLY MAINTENANCE CHECKLIST

The following maintenance checklist is intended as a guideline rather than a definitive maintenance schedule. Your equipment may require more, or less, maintenance depending upon the frequency of use, the percentage of maximum torque that your equipment is routinely subjected to, and the field conditions under which your equipment operates. McCoy Global recommends that the following inspection and maintenance procedures be performed on a monthly basis under normal operating conditions.

 **WARNING**

DO NOT PERFORM ANY FURTHER ACTIONS OR MAINTENANCE WHILE THE TONG IS CONNECTED TO ANY HYDRAULIC POWER SUPPLY. MCCOY RECOMMENDS THAT ALL HYDRAULIC LINES ARE FULLY DISCONNECTED, AND RESIDUAL HYDRAULIC PRESSURE IS BLED OFF. ENSURE ADEQUATE CONTAINMENT IS IN PLACE TO PREVENT ENVIRONMENTAL CONTAMINATION FROM RESIDUAL HYDRAULIC FLUID.

1. **DEPRESSURIZE HYDRAULIC SYSTEM IN PREPARATION FOR MAINTENANCE.**
Complete Depressurization Procedure on page 5.4.

 **WARNING**

HYDRAULIC PRESSURES AS HIGH AS OPERATING PRESSURE MAY REMAIN TRAPPED IN SMALL AREAS OF THE EQUIPMENT. ENSURE ALL MAINTENANCE IS CARRIED OUT BY A QUALIFIED SERVICE TECHNICIAN, AND THAT ADEQUATE PERSONAL PROTECTIVE EQUIPMENT IS USED.

2. Clean the exterior of the tool thoroughly, using either a water hose with a spray nozzle or a pressure washer using a low-pressure wash wand, or an appropriate solvent-based grease-cutting cleaner such as Varsol. Ensure adequate containment is in place to prevent environmental contamination from residual hydraulic fluid, dirty grease, and cleaning agents.
3. Clean the interior spaces of the tool thoroughly, using either a water hose with a spray nozzle (do not use a pressure washer), or an appropriate solvent-based grease cutting cleaner such as Varsol. Ensure adequate containment is in place to prevent environmental contamination from residual hydraulic fluid, dirty grease, and cleaning agents. If shavings or metal pieces are flushed out, the equipment must be overhauled before it is returned to service.
4. Inspect all fasteners and fastener safety wires (if equipped). Replace any missing fasteners with Grade 8 bolts only unless otherwise specified. Re-torque all external fasteners to SAE specifications.
5. Repair or replace any damaged external body parts. McCoy recommends that damaged or missing body parts be repaired or replaced as soon as possible.
6. Re-torque or replace loose or missing fasteners.
7. Inspect equipment for signs of premature wear, or moving parts that are rubbing (bare metal where there used to be paint is a good indication of wear).
8. Inspect all paint. Locations in which the paint has been damaged must be repaired prior to the equipment being returned to service. Prepare areas to be painted to ensure they are free of grease, dirt, or solvent. Touch up using a solvent-based acrylic paint. Allow sufficient time for paint to dry before proceeding.
9. Inspect all external welds. Any weld that is cracked or separating must be repaired and repainted before returning the tong to service.
10. Perform a visual inspection of all lifting points. Replace visibly damaged parts before returning the equipment to service.
11. Inspect all jaws and dies used since the last monthly inspection. Inspect jaws for signs of damage and replace if necessary. Ensure dies are secure in the jaw. Replace worn dies if necessary.
12. Extend all hydraulic cylinders, and inspect cylinder rods for signs of mechanical damage, flaking, or rust. Replace damaged cylinders before returning equipment to service.
13. Perform a visual inspection of all hydraulic lines. Replace flexible lines if they have visible signs of damage. If your equipment utilizes rigid hydraulic lines, replace any line that is visibly damaged.
14. Generously fill the gear train housing with grease. Perform a full lubrication (see page 5.5).
15. Ensure main supply and return connections to the tong are fully made up. Reconnect the remainder of the hydraulic lines, and, if applicable, the electrical lines.

5.9 MONTHLY MAINTENANCE CHECKLIST (CONTINUED):

**WARNING**

FAILURE TO ENSURE THAT THE SELF-SEALING SUPPLY AND RETURN LINES ARE FULLY MADE UP MAY RESULT IN CATASTROPHIC EQUIPMENT FAILURE.

16. Refer to control console / power unit manual for startup procedures and start power unit.
17. Ensure that supply pressure is at or above the tool's specified operating pressure, and that the return pressure is less than 350 psi.
18. Perform a visual inspection of pressurized hydraulic lines. If any hydraulic fittings or hoses are leaking they must be repaired or replaced before proceeding.
19. De-energize the power unit and perform another lubrication of the gear train, including the gear housing.
20. Energize power unit. Rotate tong for one minute, stop, and reverse the direction of rotation for another minute, ending with the opening of the rotary gear facing the gear train.
21. De-energize the power unit, and perform a third generous lubrication of the gear train, including the gear housing.
22. Rotate the tong at low speed for 5 minutes while monitoring pressurized seals and hydraulic lines. If a seal, line, or fitting begins to leak while tong is rotating, it must be replaced before the equipment is returned to service.

Rotate tong at high speed for 5 minutes while monitoring temperature of top and bottom bearing caps. If the bearing caps are hot to the touch (higher than approximately 50°C) replace the applicable bearings. Note any unusual sounds (grinding, rubbing) may be indicative of damaged bearings (see Assembly Drawings in Section 7 for all bearing locations). Monitor hydraulic inlet and outlet lines to ensure operating temperature of the hydraulic fluid does not exceed the specifications stated in Section 2.
23.
24. Install load cell. Perform a visual inspection of the load cell components and replace any damaged components.
25. Inspect the load cell anchor pins. Replace the anchor pins if cracking or metal distortion is seen.
26. Perform a full functional test of the equipment. Correct any hydraulic leaks.
27. McCoy recommends that an anti-corrosive agent such as Tectyl® 506 be applied to all external unpainted surfaces (and chain slings) EXCEPT cylinder rods, jaw rollers, and rotary gear camming surfaces. Refer to manufacturer data sheets for proper application and safety information.

Once all of the above maintenance checklist items have been satisfactorily completed the tool may be returned to service.

5.10 TUBULAR CONNECTION EQUIPMENT DECOMMISSIONING & SHIPPING

Perform the following decommissioning procedures when removing tubular connection equipment from service, with the intent of short to long-term storage. These procedures are essential for ensuring proper protection of the equipment from environmental corrosion, and to aid in the quick turnaround when returning the equipment to service.

Store all o-rings, seals, packings, gaskets, etc. in strong, moisture proof airtight containers. Ensure that these items are not crushed or otherwise damaged.

Do not perform any further actions or maintenance while the bucking unit is connected to any hydraulic power supply. McCoy Global recommends that all hydraulic lines are fully disconnected, and residual hydraulic pressure is bled off. Ensure adequate containment is in place to prevent environmental contamination from residual hydraulic fluid.

NOTICE

IN ORDER TO MAINTAIN THE INTEGRITY OF INSTALLED SEALS, MCCOY RECOMMENDS THAT THE MAXIMUM STORAGE INTERVAL NOT EXCEED ONE YEAR. AT LEAST ONCE PER YEAR ALL TUBULAR CONNECTION EQUIPMENT IN LONG-TERM STORAGE SHOULD BE RECOMMISSIONED AS PER SECTION 5. IF FURTHER STORAGE IS REQUIRED, THE EQUIPMENT SHOULD THEN BE PUT THROUGH ANOTHER DECOMMISSIONING PROCEDURE.

DEPRESSURIZE HYDRAULIC SYSTEM IN PREPARATION FOR MAINTENANCE.

1. Complete Depressurization Procedure on page 5.4.
Disconnect all remaining connections from the equipment. Ensure the tool is completely free of all connections before beginning storage preparations.

! WARNING

HYDRAULIC PRESSURES AS HIGH AS OPERATING PRESSURE MAY REMAIN TRAPPED IN SMALL AREAS OF THE EQUIPMENT. ENSURE ALL MAINTENANCE IS CARRIED OUT BY A QUALIFIED SERVICE TECHNICIAN, AND THAT ADEQUATE PERSONAL PROTECTIVE EQUIPMENT IS USED TO GUARD AGAINST PRESSURE INJURIES

2. Perform an initial wash of the tool in order to remove the majority of dirt and grease build-up. Ensure adequate containment is in place to prevent environmental contamination from residual hydraulic fluid and dirty grease.
3. Clean the exterior of the tool thoroughly, using either water (do not use a pressure washer), or an appropriate solvent-based grease-cutting cleaner such as Varsol. Ensure adequate containment is in place to prevent environmental contamination from residual hydraulic fluid, dirty grease, and cleaning agents.
4. Inspect all fasteners and fastener safety wires (if equipped). Replace any missing fasteners. Use Grade 8 bolts only unless otherwise specified. Re-torque all external fasteners to SAE specifications.
5. Repair or replace any damaged external body parts.
6. Inspect all paint. Locations in which the paint has been damaged must be repaired prior to storage. Prepare areas to be painted to ensure they are free of grease, dirt, or solvent. Touch up using a solvent-based acrylic paint, and allow sufficient time for paint to dry before proceeding.
7. Perform a lubrication of the equipment. Refer to Maintenance Section of this manual for lubrication diagrams. Generously fill the gear train housing with grease.
8. Connect the equipment to a hydraulic power unit. Ensure all quick-connect control lines are securely connected to prevent equipment damage from excessive back pressure. Do not neglect to connect the motor drain.
9. Refer to control console / power unit manual for startup procedures and start power unit.
10. Rotate tong for one (1) minute in both the 'Make Up' and 'Break Out' directions. De-energize the power unit, and perform another generous lubrication of the gear train, including the gear housing.
11. Start the power unit again. Rotate tong for one (1) minute in both the 'Make Up' and 'Break Out' directions.

5.10 TUBULAR CONNECTION EQUIPMENT DECOMMISSIONING & SHIPPING (CONTINUED):

12. De-energize the power unit. Perform a third generous lubrication of the gear train, including the gear housing.
13. Start the power unit again. Rotate tong for one (1) minute in both the 'Make Up' and 'Break Out' directions.
14. Extend all hydraulic cylinders and inspect cylinder rods for signs of mechanical damage, flaking, or rust. Damaged cylinders be replaced prior to storage.
15. The backup must be secured to the frame in order to remove the risk of sudden and catastrophic movement during transport. Prep the equipment for shipping as shown on page 5.18.

DEPRESSURIZE HYDRAULIC SYSTEM IN PREPARATION FOR MAINTENANCE.

1. Complete Depressurization Procedure on page 5.4.
 2. Connect a low-pressure air supply line (10 PSI or less) to the hydraulic supply line, and force a small amount of the remaining hydraulic fluid from the valve assembly. Failure to do this may result in damaged or destroyed seals in the equipment.
16.
3. Disconnect the hydraulic RETURN line from the equipment.
 4. Disconnect all remaining quick-connect hoses.
 5. Disconnect all remaining connections from the equipment. Ensure the tool is completely free of all connections before beginning storage preparations.
17. Repair or replace all leaking hydraulic fittings or hoses before proceeding.
18. Use a solvent-based cleaner on rags to wipe all external surfaces to remove all residual grease or hydraulic fluid. Once the exterior surfaces have been de-greased, wipe all external surfaces with clean water to remove residual solvent.
19. Apply grease or heavy oil to all exposed cylinder rods.
20. McCoy recommends that an anti-corrosive agent such as Tectyl® 506 be applied to all external surfaces EXCEPT cylinder rods (including chain slings). Refer to manufacturer data sheets for proper application and safety information.

CAUTION

DO NOT ALLOW ANTI-CORROSIVE AGENTS TO CONTACT CYLINDER RODS. CYLINDER ROD DAMAGE WILL OCCUR.

21. Allow the anti-corrosive coating ample time to dry. Refer to manufacturer data sheets for drying times at room temperature.
22. Wrap entire assembly in 100 gauge (1 mil) corrosion-inhibiting wrap, at least 3 layers thick. Attempt to ensure that the tool is well-sealed within the wrapping, including the bottom.

Store in a sealed, climate controlled environment. If isolated storage is not available, McCoy recommends storing wrapped equipment using silica gel desiccant to reduce the humidity within the wrapping. As a guideline, use 125 g. of desiccant for each cubic meter of space, or 3.5 g. per cubic foot.

Calculation Of Required Desiccant:

- 1) Calculate the trapped air volume by measuring the outside dimensions of the tool to be stored, and treat that as the volume to be stored. For example, the overall external dimensions of this tool are 96.5" x 96.5" x 64.5", which calculates to an approximate volume of 600640 in³, or 348 ft³ (9.854 m³).
- 2) Multiply the calculated air volume, in cubic feet, by the recommended amount of desiccant (3.5 g) per cubic foot. Carrying forth the example used in the previous step, the required desiccant charge would be 3.5 g. x 348 ft³, equaling 1218 g. Several manufacturers offer silica gel desiccant in packaged quantities of 125 grams per bag, so ten packages of desiccant distributed throughout the wrapped equipment would be required. Please keep in mind that this is a guideline only - more or less desiccant may be required in extreme environmental conditions.

For best corrosion resistance, the equipment should be removed from storage and exercised on a regular basis, depending on the storage environment. McCoy recommends that for equipment stored in a saltwater maritime or exposed dusty environment, repeat steps 9 through 24 monthly. For equipment stored in isolated storage in a non-maritime environment, repeat steps 9 through 24 quarterly. Replace desiccant packs at this time.

5.10 TUBULAR CONNECTION EQUIPMENT DE-COMMISSIONING & SHIPPING (CONTINUED):**5.10.1 Shipping Instructions**

Use the following steps to prepare the equipment for shipping.

1. Position the backup at its fully extended position against the bumper stops on the rear of the skid.
2. Fully depressurize the equipment. Disconnect any hoses and cables as necessary.
3. Mount 4"x4" wooden beams snugly in between the backup and tong bumpers to prevent any lateral movement of the backup.
4. Remove all bucking unit accessories and attached WINCATT® torque turn computer. See WINCATT® manual for shipping instructions. Wrap bucking unit accessories and associated fasteners in protective wrap and place in a separate wooden crate.
5. Place the equipment on a pallet rated for the full weight of the equipment. Ensure the pallet is large enough to accommodate the wooden crate containing the tong accessories.
6. Securely strap the equipment in place using metal strapping. Use caution not to entrap any flexible hydraulic hoses beneath the strapping (guide strapping through beneath the hydraulic hoses). Strapping requirements such as strap thickness and number of straps must be determined using a recognized standard, taking into account the full weight of the equipment being secured.
7. Before tightening strapping, place strapping protectors wherever the metal strapping comes into contact with the equipment. Never allow straps to cover components that may easily be bent or broken.
8. Place the wooden crate containing the tong accessories on the crate next to the equipment. Strap the crate to the pallet using appropriate metal strapping. If it is not practical to place larger loose items in a wooden crate, ensure they are also securely strapped to the pallet appropriate metal strapping.
9. Use a large polyethylene shipping bag (sometimes called a pallet cover) to completely enclose the equipment. Seal polyethylene bag to the pallet using 1 mil polyethylene wrap. Use the wrap to conform the plastic cover to the general shape of the equipment, but do not wrap so tight that sharp edges on the equipment perforate the cover.
10. Enclose the equipment in a sturdy shipping crate which is securely fastened to the pallet.

5.11 TUBULAR CONNECTION EQUIPMENT RECOMMISSIONING PROCEDURE

Perform the following recommissioning procedures when removing tubular connection equipment from short or long-term storage back into regular service. These procedures are essential for ensuring proper equipment preparation and operation. The following procedures also assume that the decommissioning and storage procedures recommended by McCoy have been strictly observed.

1. Remove all protective plastic wrapping and dispose of desiccant packs.
2. Wipe excess grease or heavy oil from exposed cylinder rods.
3. Perform a visual inspection of all lifting points. Replace visibly damaged parts before returning the equipment to service. Ensure that the most recent test date falls within the past year. Perform recertification if necessary.
4. Remove shipping components from the equipment. Store for future use.
5. Perform a full lubrication of the equipment. See page 5.5 for equipment grease diagrams. Generously fill the gear train housing with grease through the tong access panel.
6. Connect the equipment to a hydraulic power unit. Ensure all lines are fully made up to prevent equipment damage from excessive back pressure. Do not neglect to connect the motor drain.

 **WARNING**

FAILURE TO ENSURE THAT THE SELF-SEALING SUPPLY AND RETURN LINES ARE FULLY MADE UP MAY RESULT IN CATASTROPHIC EQUIPMENT FAILURE.

7. Refer to control console / power unit manual for startup procedures and start power unit.
8. Ensure that supply pressure is at or above the equipment's specified operating pressure, and that the return pressure is less than 350 psi.
9. Perform a thorough inspection of pressurized hydraulic lines and fittings. Leaking hydraulic fluid lines or fittings must be replaced before returning the equipment to service.
10. Perform a thorough inspection of all seals. Any seal that is leaking must be replaced before returning the equipment to service.
11. Rotate tong at low speed for 5 minutes while monitoring pressurized seals and hydraulic lines. If a seal, line, or fitting begins to leak while tong is rotating, it must be replaced before returning the equipment to service. De-energize the power unit.
12. Inspect all flexible hydraulic lines for damage or any other signs of potential failure. Replace if necessary.
13. Inspect the gear train housing to assure geartrain is thoroughly greased. Apply additional grease if necessary.
14. Re-install access panel. Install a set of pre-inspected jaws that are the correct size for the pipe or casing being run.
15. Install load cell. Perform a visual inspection and replace any damaged components.
16. Inspect the load cell anchor pins. Replace the anchor pins if cracking or metal distortion is seen.
17. Energize power unit.
18. Perform a full functional test of the equipment. Correct any hydraulic leaks.
19. When all of the previous steps are completed, you may return your re-commissioned equipment to service.



**This page intentionally
left blank**



SECTION 6: TROUBLESHOOTING



**This page intentionally
left blank**

Adequate maintenance and proper fluid selection is essential for minimizing hydraulic-related failures. All troubleshooting must be performed by a technician trained in hydraulics who is also familiar with the equipment design, assembly, and operation.

The following troubleshooting instructions are intended to be guidelines only. Any faults not solved through the use of this guide should be referred to our engineering department for their evaluation and recommendations.

6.0 TONG WILL NOT DEVELOP SUFFICIENT TORQUE

| | POSSIBLE PROBLEM | SOLUTION(S) |
|---|---|---|
| 1 | Malfunctioning relief valve on tong hydraulic circuit | Troubleshoot relief valve as per OEM instructions. |
| 2 | Directional valve is leaking | Check directional valve. Neutral position should return fluid directly to the reservoir. Replace or repair valve to ensure correct operation. See Section 9 for OEM documentation. |
| 3 | Power unit is not producing adequate pressure | Troubleshoot power unit (see power unit user's manual) |
| 4 | Poor hydraulic pressure at the tong despite adequate pressure at the power unit, or excessive back pressure in the return line. | Restrictions exist in line between power unit and tong. Inspect integrity of self-sealing couplings to ensure they are allowing full fluid flow. Check to ensure no other restrictions exist (contaminated catch screens or filters, for example) |
| 5 | Fluid viscosity is not appropriate (too high or too low) | Ensure hydraulic fluid being used is the viscosity recommended by McCoy Global. Power unit pump may not prime if fluid is too heavy, and the hydraulic system will overheat if fluid is too light. Replace with proper viscosity fluid |
| | | Hydraulic fluid viscosity is affected by environmental conditions. Ensure the fluid being used is suitable for high or low temperatures. Replace with proper viscosity fluid for the operating conditions if necessary |
| 6 | Worn or damaged tong motor causing slippage | Replace or repair worn or damaged motor |
| 7 | Damaged bearings or gears causing excessive drag | Replace or repair worn or damaged gears or bearings |
| 8 | Jaws slipping on pipe | Ensure jaw dies are not worn to the point that they cannot grip. Ensure the correct sized jaws are in use |
| 9 | Load cell is measuring incorrectly | Incorrect load cell is being used |
| | | Load cell has been damaged. Replace load cell, or return to McCoy for repair and re-calibration |

NOTICE

MCCOY GLOBAL GUARANTEES CALIBRATION OF A LOAD CELL/TORQUE GAUGE ASSEMBLY FOR A PERIOD OF ONE YEAR. THE LOAD CELL/TORQUE GAUGE ASSEMBLY MUST BE RETURNED TO THE FACTORY FOR RE-CALIBRATION ON A YEARLY BASIS.

| | POSSIBLE PROBLEM | SOLUTION(S) |
|----|---|---|
| 10 | Incorrect motor speed selected (applies to 2-speed motors only) | Maximum torque can only be developed when LOW motor speed (maximum hydraulic displacement) is selected. |

6.1 FAILURE OF JAWS TO GRIP PIPE

| | POSSIBLE PROBLEM | SOLUTION(S) |
|----------|--|---|
| 1 | Dies have become too dull to provide adequate grip | Replace dies |
| 2 | Incorrect jaws are being used | Double-check jaw size to ensure they are rated for the diameter of pipe being run |
| 3 | Incorrect dies are being used | Ensure dies loaded in the jaws are appropriate for the type of pipe or casing being run |

6.2 TONG RUNNING TOO SLOWLY

| | POSSIBLE PROBLEM | SOLUTION(S) |
|----------|--|---|
| 1 | Obstruction in hydraulic circuit preventing adequate flow | Inspect self-sealing couplings to ensure they are properly engaged |
| | | The main hydraulic lines (supply and discharge) to the equipment are obstructed. Remove and clean if required |
| 2 | Power unit is not producing adequate flow or pressure | Troubleshoot power unit (see power unit user's manual) |
| 3 | Tong motor is excessively worn and is leaking hydraulic fluid past the vanes | Replace or rebuild hydraulic motor. |
| 4 | Bearings in gear train and rotary section are excessively worn | Overhaul tong. Contact McCoy for instructions. |
| 5 | Hydraulic fluid viscosity too high | Ensure hydraulic fluid meets McCoy Global specifications |
| | | Ensure hydraulic fluid is appropriate for climatic conditions, especially during cold-weather operation |
| 6 | By-pass valve not functioning | Check and repair |

6.3 EQUIPMENT WILL NOT ENGAGE PIPE, OR DOES NOT PROVIDE ADEQUATE GRIP

| | POSSIBLE PROBLEM | SOLUTION(S) |
|---|--|---|
| 1 | Hydraulic clamp cylinder failure or malfunction | Rebuild hydraulic cylinder(s). Disassemble, clean, and install new seal kit. Replace all damaged components (see Section 7) |
| | | Install new hydraulic cylinder(s) |
| 2 | Inadequate lubrication of clamping cylinder | Grease cylinder as per instructions in Maintenance Section |
| 3 | Metal fragment has become lodged between clamping cylinder and a fixed piece of the backup | Thoroughly inspect area around clamp cylinder and remove the metal fragment. Following removal of the fragment inspect moving components to ensure the metal has not been gouged or chipped. Damaged components may require replacement to ensure smooth cylinder movement. |

! WARNING

HYDRAULIC PRESSURES AS HIGH AS OPERATING PRESSURE MAY REMAIN TRAPPED IN SMALL AREAS OF THE EQUIPMENT. ENSURE ALL MAINTENANCE IS CARRIED OUT BY A QUALIFIED SERVICE TECHNICIAN, AND THAT ADEQUATE PERSONAL PROTECTIVE EQUIPMENT IS USED TO GUARD AGAINST PRESSURE INJURIES

| | POSSIBLE PROBLEM | SOLUTION(S) |
|---|---|---|
| 4 | Incorrect size of die holders / jaws are being used | Double-check jaw size to ensure they are rated for the diameter of pipe or casing being run |
| 5 | Dies have become too dull to provide adequate grip | Replace dies |
| 6 | Incorrect dies are being used | Ensure dies loaded in the jaws are appropriate for the type of pipe or casing being run |

6.4 GENERAL COMMENTS

The following factors generally contribute to poor hydraulic operation and premature wear of equipment:

1. Contaminated hydraulic fluid due to overuse, overheating, or inadequate fluid filtration.
2. Unsuitable hydraulic fluid, especially in extreme climatic conditions.
3. Defective packing or seals in components of the hydraulic system.
4. Poor or incomplete hydraulic system training. Users must be fully qualified to operate the equipment, and have complete understanding of the hydraulic system.

If your hydraulic troubleshooting procedures involve flow and pressure tests at the power unit, use of a test rig that can easily be connected to the main suction and discharge ports of the power unit is recommended.



**This page intentionally
left blank**



SECTION 7: PARTS & ASSEMBLIES



**This page intentionally
left blank**

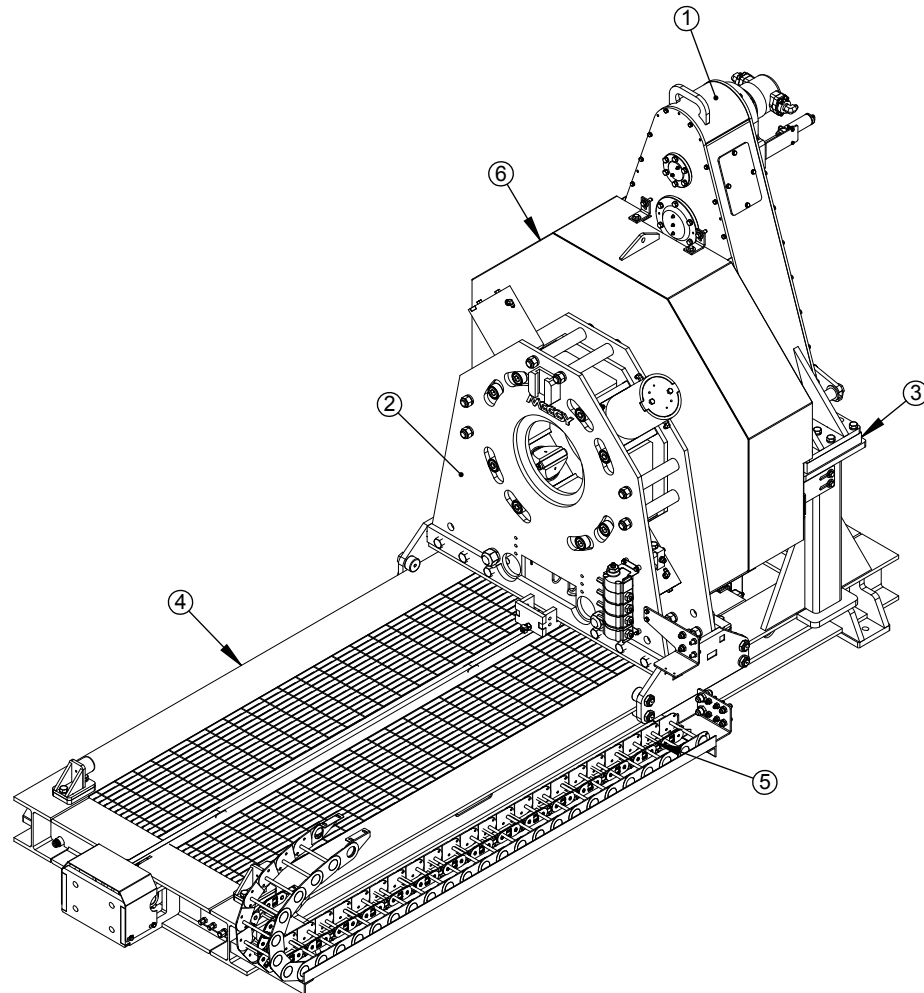

| ITEM | QTY | P/N | DESCRIPTION |
|------|-----|---------------|--------------------------------------|
| 1 | 1 | 200-6012-1 | HEADSTOCK ASSEMBLY |
| 2 | 1 | 300-6500-12 | 12 3/4" TAILSTOCK ASSEMBLY |
| 3 | 2 | CB11001-01-S5 | WELDMENT#5 |
| 4 | 1 | 500-6012-12 | 12 FEET SKID ASSEMBLY FOR RP6012 |
| 5 | 1 | 550C-3000-02 | HOSE CARRIER |
| 6 | 1 | 3000-6500-03 | 16.5 IN ROTATING HEAD GUARD ASSEMBLY |

Illustration 7.1: RP6012 Continuously Rotating Bucking Unit Assembly

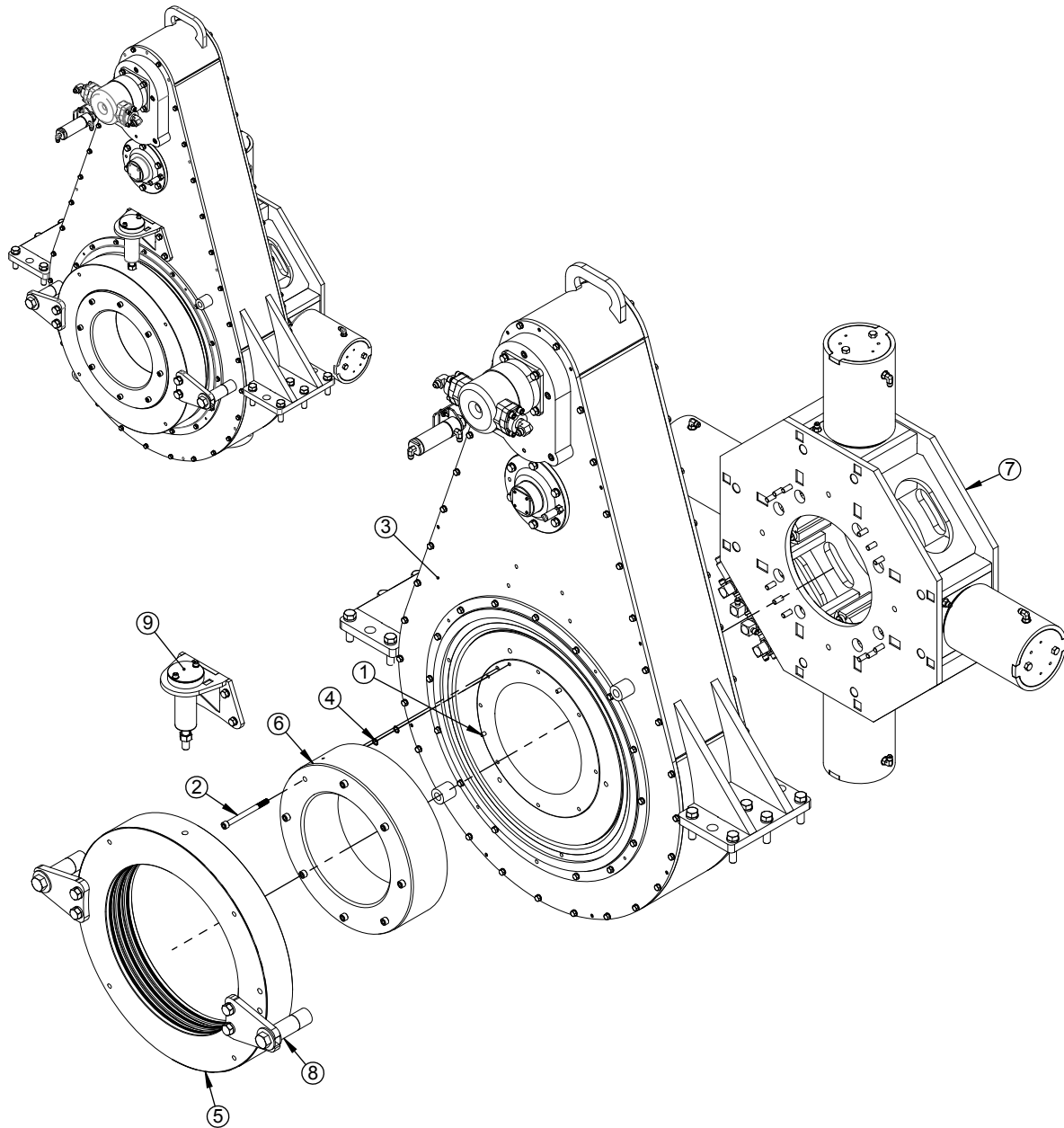

| ITEM | QTY | P/N | DESCRIPTION |
|------|-----|--------------|------------------------------------|
| 1 | 2 | 1023-M | DOWEL PIN 3/8" X 1" |
| 2 | 8 | 1815 | SHCS 1/2"-13 X 6" ALLOY GRADE |
| 3 | 1 | 200-6012 | TONG ASSEMBLY |
| 4 | 2 | 2-113 | O RING-9/16"ID 3/4"OD 3/32"WIDTH * |
| 5 | 1 | 2026-6500-1 | SWIVEL ASSEMBLY |
| 6 | 1 | 227A-6012 | HUB EXTENSION F/ RP6512 |
| 7 | 1 | 250-6500-12 | HEADSTOCK VISE ASSEMBLY |
| 8 | 2 | 2700-7000-01 | SWIVEL KEEPER ASSY. |
| 9 | 1 | 2000-7000-02 | SWIVEL SUPPORT ASSEMBLY |

Illustration 7.2: 200-6012-1 Tong Assembly

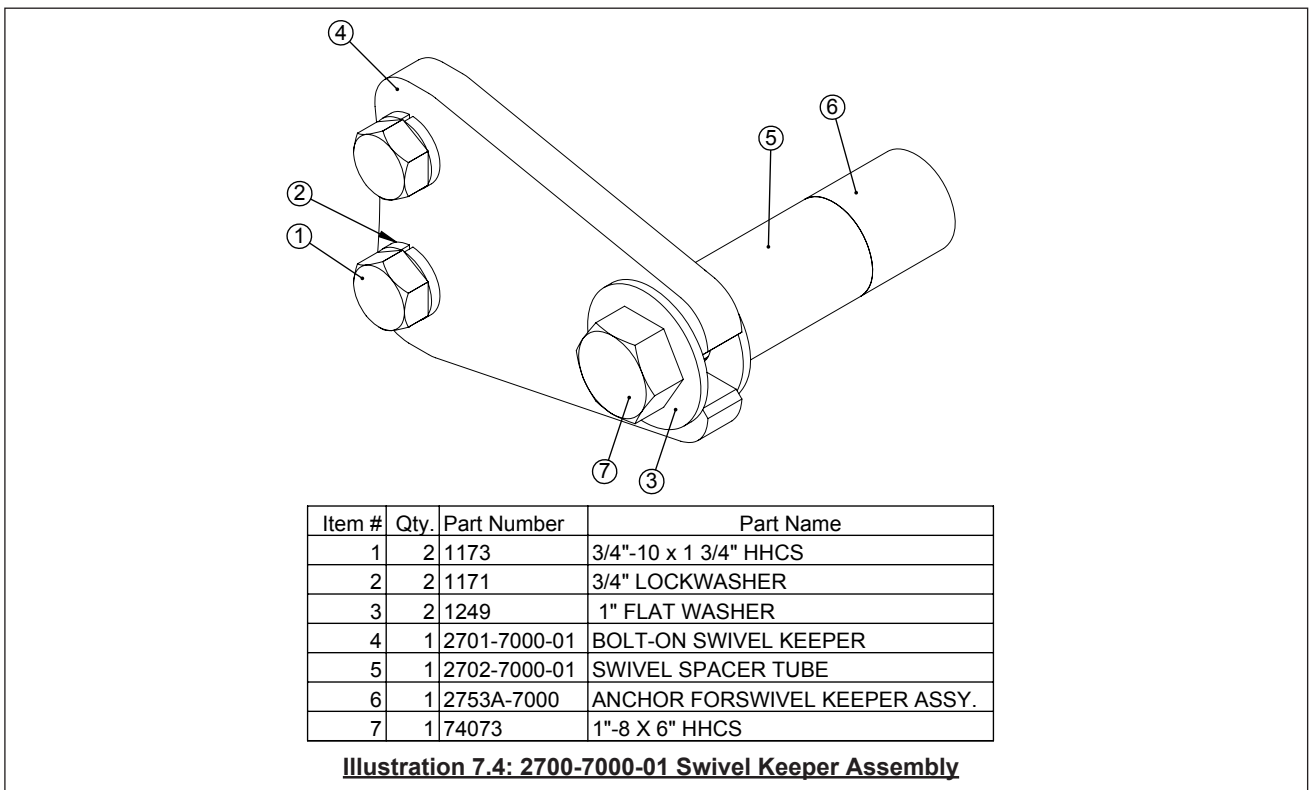
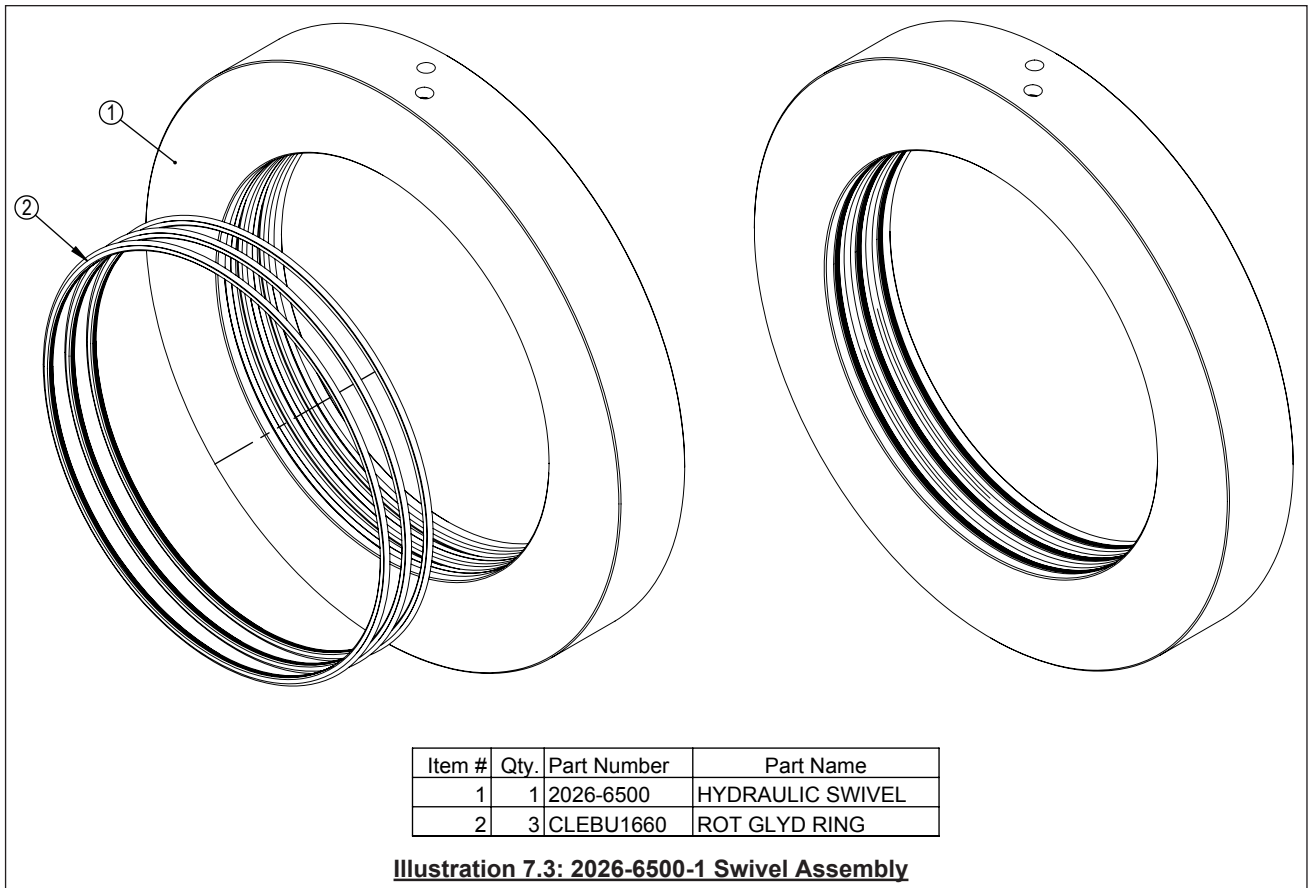

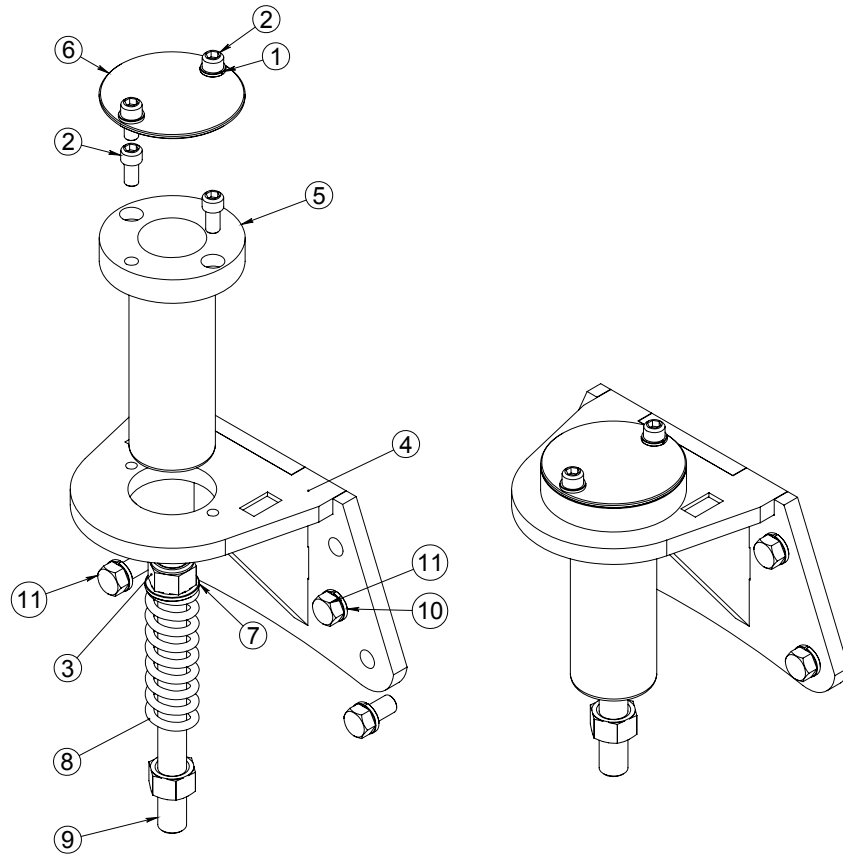

| Item # | Qty. | Part Number | Part Name |
|--------|------|--------------|-------------------------|
| 1 | 2 | 1027 | WASHER, LOCK 3/8" |
| 2 | 4 | 1040-A | 3/8-16 x 3/4 SHCS |
| 3 | 1 | 1167 | 3/4-10 NYLOCK HEX NUT |
| 4 | 1 | 2001-7000-02 | SWIVEL SUPPORT WELDMENT |
| 5 | 1 | CB2322 | SPRING TUBE |
| 6 | 1 | CB2323 | SPRING COVER |
| 7 | 1 | CB2324 | SPRING WASHER |
| 8 | 1 | CB2326 | COMPRESSION SPRING |
| 9 | 1 | CB2325-04 | LIFTING ROD WELDMENT |
| 10 | 4 | 1103 | 1/2" LOCKWASHER |
| 11 | 4 | 1110 | 1/2"-13 x 1" HHCS |

Illustration 7.5: 2000-7000-02 Swivel Support Assembly

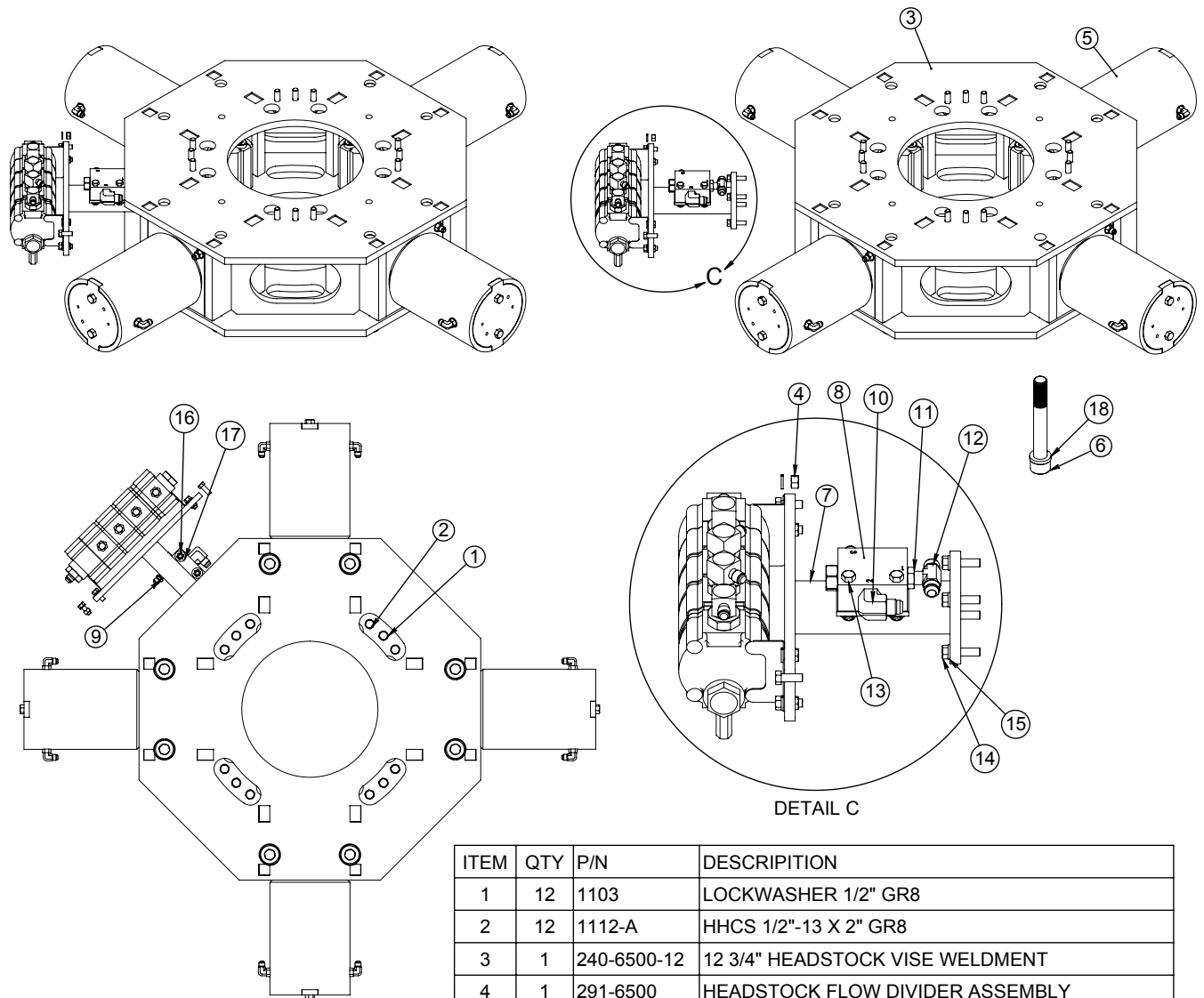

| ITEM | QTY | P/N | DESCRIPTION |
|------|-----|-------------|--|
| 1 | 12 | 1103 | LOCKWASHER 1/2" GR8 |
| 2 | 12 | 1112-A | HHCS 1/2"-13 X 2" GR8 |
| 3 | 1 | 240-6500-12 | 12 3/4" HEADSTOCK VISE WELDMENT |
| 4 | 1 | 291-6500 | HEADSTOCK FLOW DIVIDER ASSEMBLY |
| 5 | 4 | 400-3000-1 | CLAMP CYLINDER ASSEMBLY |
| 6 | 8 | 1805-A | SHCS 1 1/4"-7 X 9" ALLOY GRADE |
| 7 | 1 | 253-6500-2 | FLOW DIVIDER MOUNT WELDMENT RP6000 |
| 8 | 1 | BUC5524-01 | PILOT OPERATOR CHECK VALVE (3000 PSI ONLY) |
| 9 | 1 | 1559 | 1/4" MNPT X 3/8" MJIC STRAIGHT |
| 10 | 1 | 1626 | 90 1/2 MNPT X 1/2 MJIC |
| 11 | 1 | 1491 | REDUCER BUSHING 1/2" X 3/8" |
| 12 | 1 | 1599-A | BRANCH TEE 3/8 MNPT X MJIC |
| 13 | 2 | 1055 | HHCS 3/8"-16 X 2 1/4" GR8 |
| 14 | 4 | 1049 | HHCS 3/8"-16 X 1 1/2" GR8 |
| 15 | 4 | 1027 | LOCKWASHER 3/8" GR8 |
| 16 | 2 | 213 | NYLOCK NUT 3/8"-16 GR8 |
| 17 | 2 | 1025 | FLATWASHER 3/8" GR8 |
| 18 | 8 | 1216 | LOCKWASHER 1 1/4" ** GRADE 5 ONLY ** |

Illustration 7.6: 250-6500-12 Tong Vise Assembly

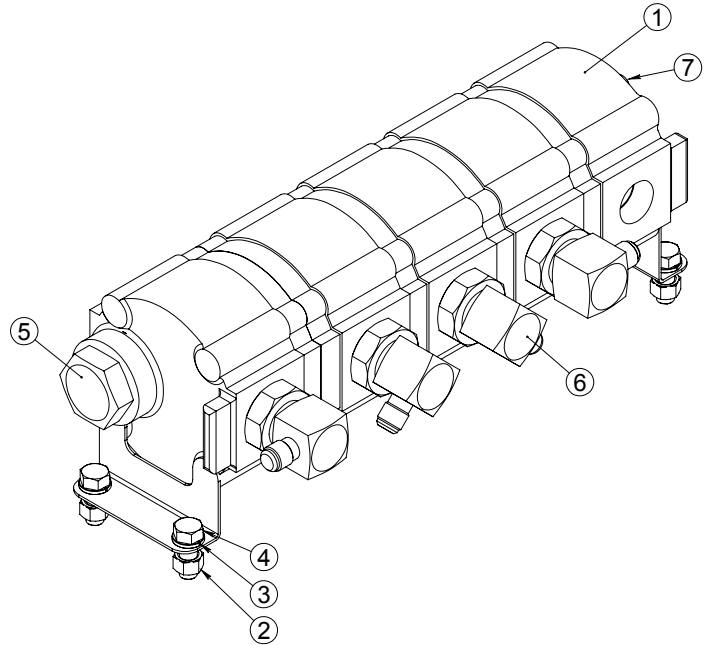

| Item # | Qty. | Part Number | Part Name |
|--------|------|--------------|----------------------|
| 1 | 1 | 1001-S1-6500 | DELTA FLOW DIVIDER |
| 2 | 4 | 1024 | 3/8-16 NUT (1024) |
| 3 | 4 | 1027 | WASHER, LOCK 3/8" |
| 4 | 4 | 1047 | 3/8"-16 X 1" HHCS |
| 5 | 1 | 16_p5on-s | 1" M ORING PLUG |
| 6 | 4 | 6801-06-12 | 3/8" MJIC X O-RING |
| 7 | 1 | 8-16 F5OX-S | 1/2" MJIC X 1" ORING |

Illustration 7.7: 291-6500 Tong Flow Divider Assembly

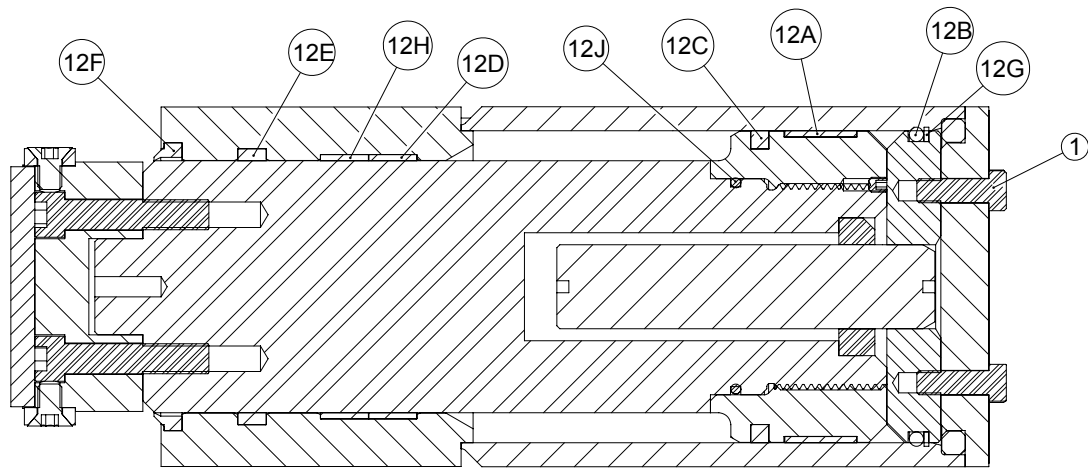

SECTION A-A
SCALE 1 : 4

****NOTE****
TEST PRESSURE: 2000PSI
WORKING PRESSURE: 1500 PSI

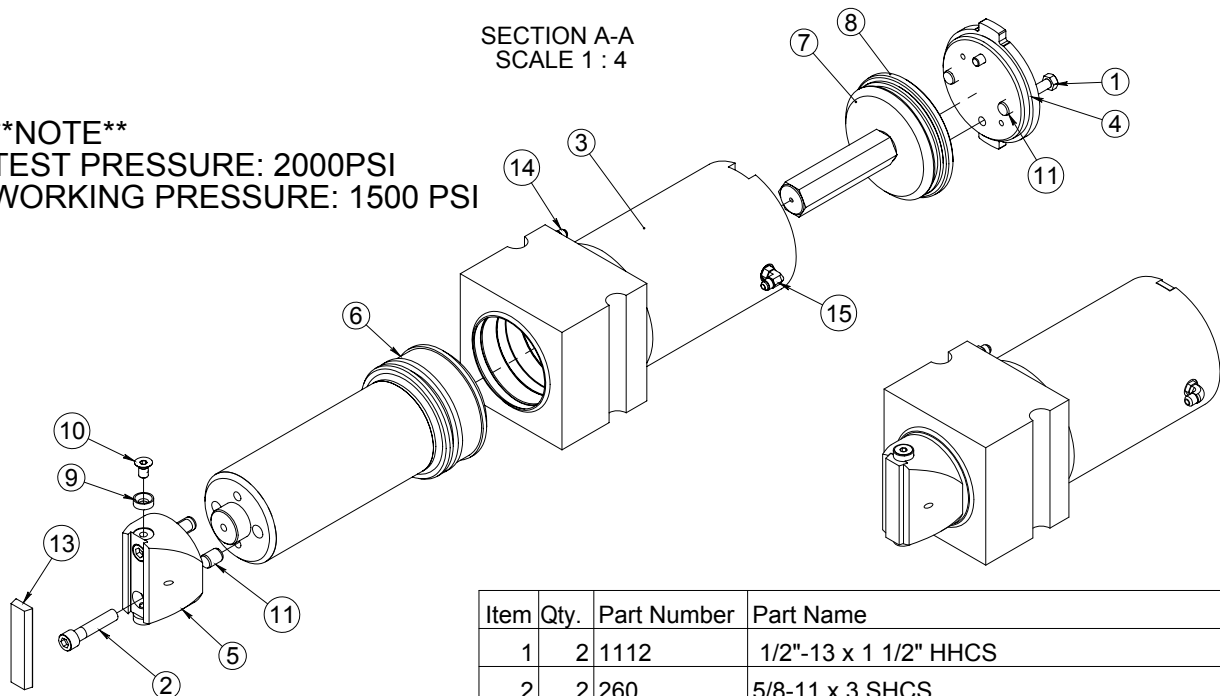

| SEALS KIT | | |
|-----------|---------------|----------------|
| 12A | W65001500 | WEAR BAND |
| 12B | BN70437 | O-RING |
| 12C | PS1800-104 | PISTON SEAL |
| 12D | W55001000 | WEAR BAND |
| 12E | 2500-5250-562 | ROD SEAL |
| 12F | D-5250 | WIPER SEAL |
| 12G | 8-437 | O-RING BACK UP |
| 12H | W55001000 | WEAR BAND |
| 12J | 2-346 | O-RING |

| Item | Qty. | Part Number | Part Name |
|------|------|-------------|---|
| 1 | 2 | 1112 | 1/2"-13 x 1 1/2" HHCS |
| 2 | 2 | 260 | 5/8-11 x 3 SHCS |
| 3 | 1 | 400-3000 | CYLINDER BLOCK HOUSING WELDMENT |
| 4 | 1 | 401-3000-02 | END PLATE |
| 5 | 1 | 402-3000 | STANDARD JAW HOLDER |
| 6 | 1 | 403A-3000-2 | PISTON ASSEMBLY |
| 7 | 1 | 404-3000 | SEAL PLATE WELDMENT |
| 8 | 1 | 405-3000 | SPLIT RING |
| 9 | 2 | 408-3000 | 1/2" WASHER |
| 10 | 2 | 91253B | SHCS Flat 1/2"-13 x 7/8" |
| 11 | 4 | 400-3001 | DOWEL PIN, 3/4" X 1" LG |
| 12 | 1 | 400C-3000 | SEAL KIT |
| 13 | 1 | DTI1602 | 1.250W X .500T X 5.000L |
| 14 | 1 | 1717 | 3/8 MJIC X O-RING BOSS ADAPTER STRAIGHT |
| 15 | 2 | 1687 | 3/8" O-RING x 3/8" MJIC ELBOW |

Illustration 7.8: 400-3000-1 Clamp Cylinder

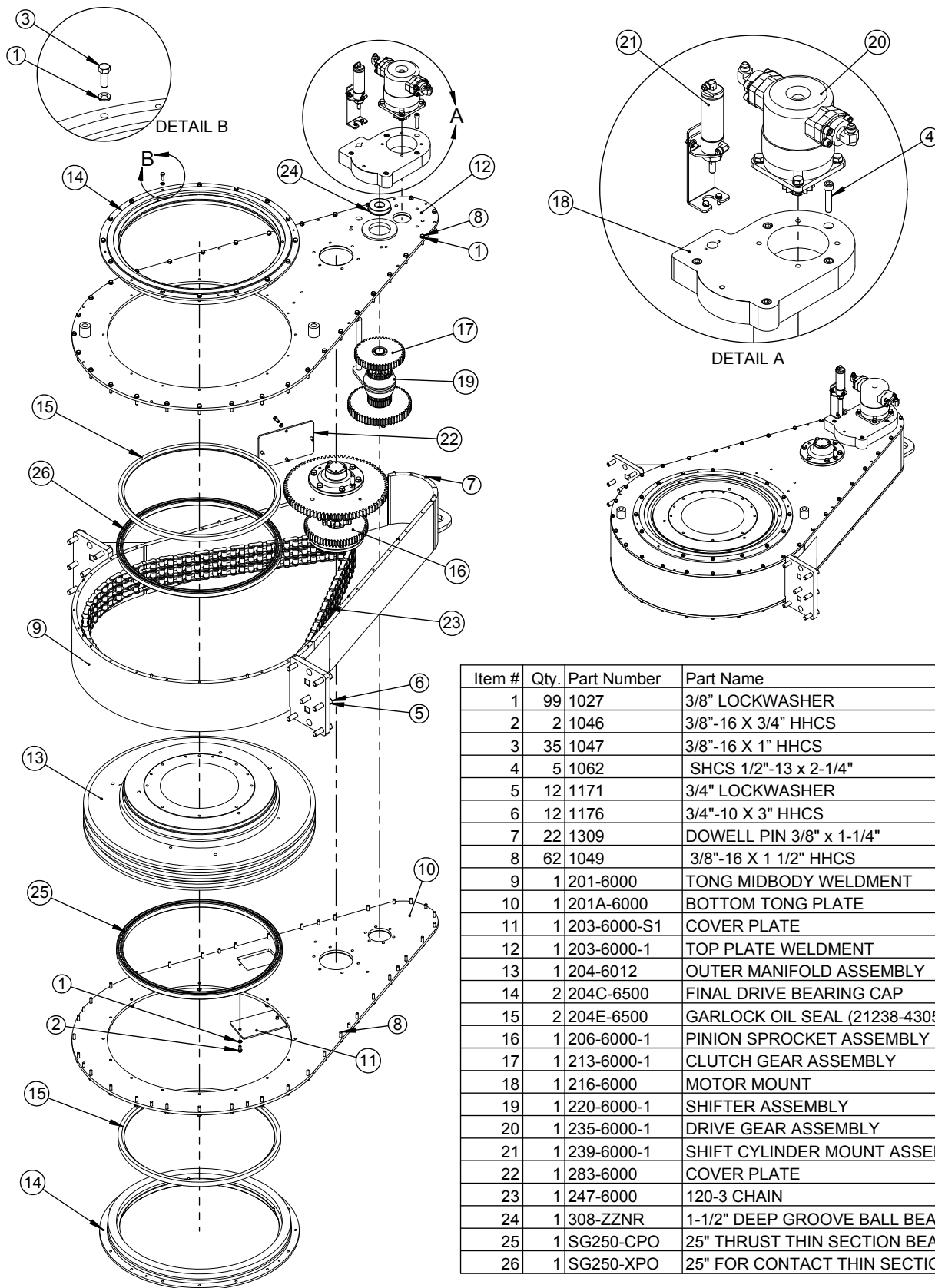

| Item # | Qty. | Part Number | Part Name |
|--------|------|-------------|--------------------------------------|
| 1 | 99 | 1027 | 3/8" LOCKWASHER |
| 2 | 2 | 1046 | 3/8"-16 X 3/4" HHCS |
| 3 | 35 | 1047 | 3/8"-16 X 1" HHCS |
| 4 | 5 | 1062 | SHCS 1/2"-13 x 2-1/4" |
| 5 | 12 | 1171 | 3/4" LOCKWASHER |
| 6 | 12 | 1176 | 3/4"-10 X 3" HHCS |
| 7 | 22 | 1309 | DOWELL PIN 3/8" x 1-1/4" |
| 8 | 62 | 1049 | 3/8"-16 X 1 1/2" HHCS |
| 9 | 1 | 201-6000 | TONG MIDBODY WELDMENT |
| 10 | 1 | 201A-6000 | BOTTOM TONG PLATE |
| 11 | 1 | 203-6000-S1 | COVER PLATE |
| 12 | 1 | 203-6000-1 | TOP PLATE WELDMENT |
| 13 | 1 | 204-6012 | OUTER MANIFOLD ASSEMBLY |
| 14 | 2 | 204C-6500 | FINAL DRIVE BEARING CAP |
| 15 | 2 | 204E-6500 | GARLOCK OIL SEAL (21238-4305) |
| 16 | 1 | 206-6000-1 | PINION SPROCKET ASSEMBLY |
| 17 | 1 | 213-6000-1 | CLUTCH GEAR ASSEMBLY |
| 18 | 1 | 216-6000 | MOTOR MOUNT |
| 19 | 1 | 220-6000-1 | SHIFTER ASSEMBLY |
| 20 | 1 | 235-6000-1 | DRIVE GEAR ASSEMBLY |
| 21 | 1 | 239-6000-1 | SHIFT CYLINDER MOUNT ASSEMBLY |
| 22 | 1 | 283-6000 | COVER PLATE |
| 23 | 1 | 247-6000 | 120-3 CHAIN |
| 24 | 1 | 308-ZZNR | 1-1/2" DEEP GROOVE BALL BEARING |
| 25 | 1 | SG250-CPO | 25" THRUST THIN SECTION BEARING |
| 26 | 1 | SG250-XPO | 25" FOR CONTACT THIN SECTION BEARING |

Illustration 7.9: 200-6012 Tong Assembly

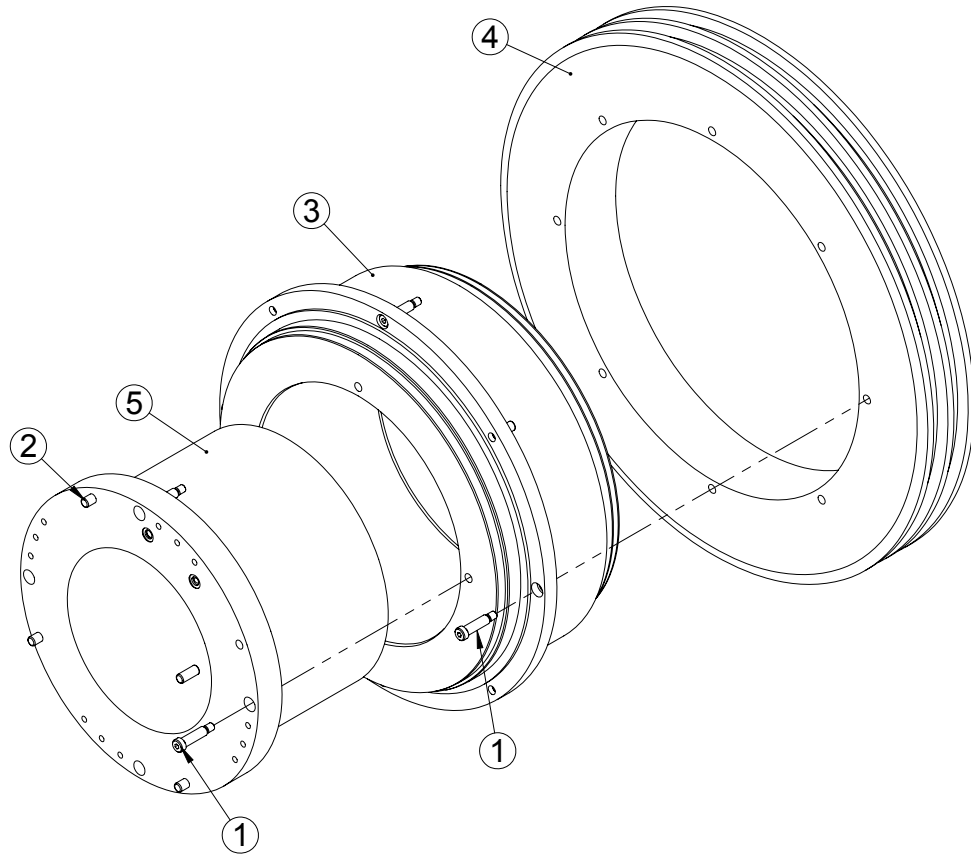

| Item # | Qty. | Part Number | Part Name |
|--------|------|-------------|-------------------------|
| 1 | 8 | 1200 | SHOULDER BOLT 5/8" x 2" |
| 2 | 8 | 1228 | 5/8 x 1 1/2 DOWEL PIN |
| 3 | 1 | 204A-6012 | FINAL DRIVE |
| 4 | 1 | 204B-6000 | SPROCKET |
| 5 | 1 | 227-6012 | SWIVEL HUB |

Illustration 7.10: 204-6012 Outer Manifold Assembly

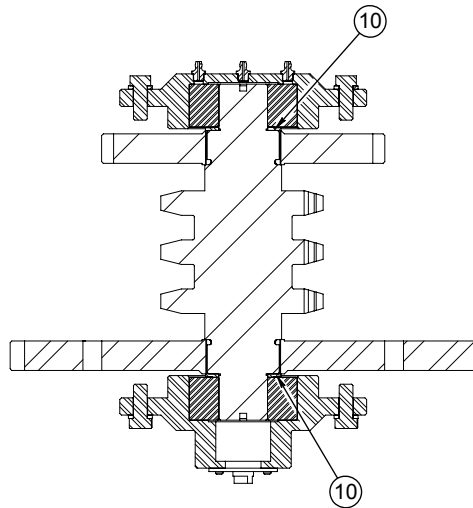
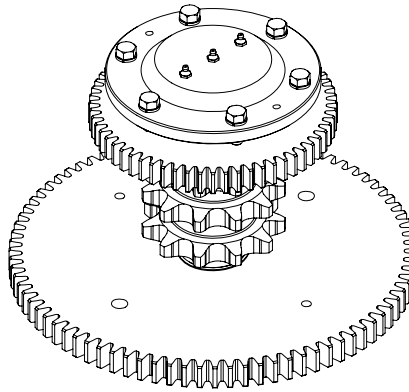
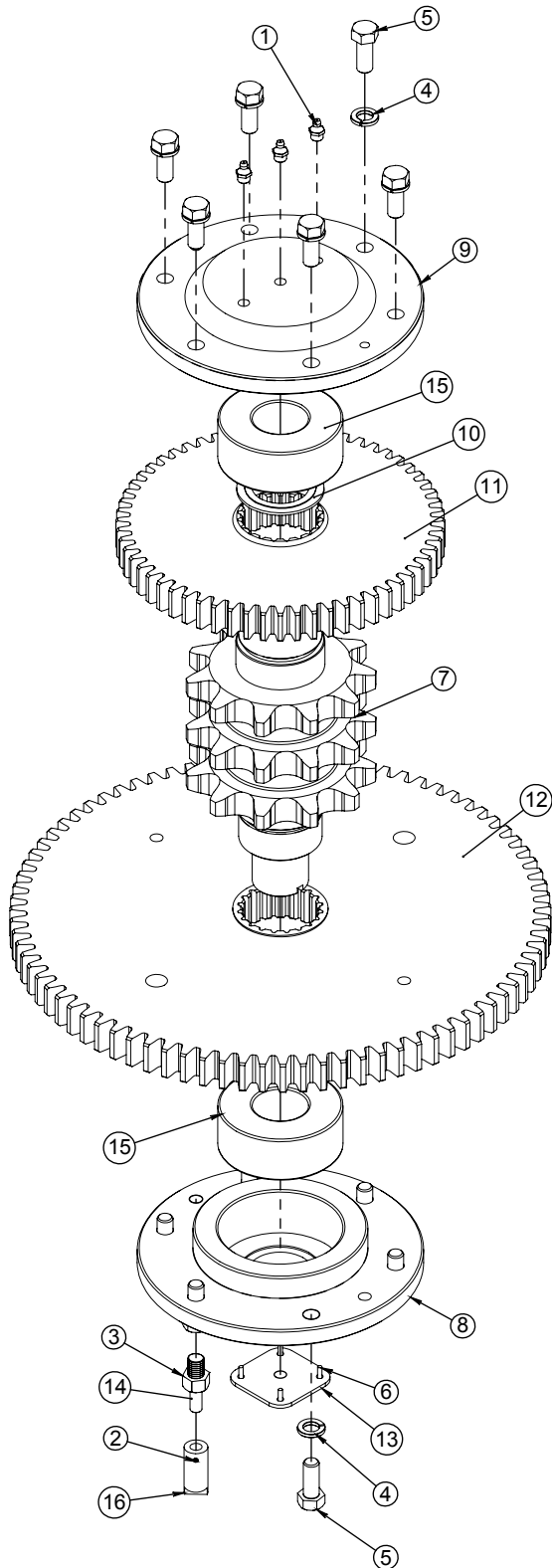

| Item # | Qty. | Part Number | Part Name |
|--------|------|--------------|--------------------------------|
| 1 | 3 | 1001 | 1/8" GREASE FITTING |
| 2 | 1 | 1034 | #10-32 X 1/4" SET SCREW |
| 3 | 1 | 1101 | 1/2"-13 HEX NUT |
| 4 | 12 | 1103 | 1/2" LOCKWASHER |
| 5 | 12 | 1111 | 1/2"-13 x 1 1/4" HHCS |
| 6 | 4 | 1276-B | #6-32 X 3/8" MACHINE SCREW |
| 7 | 1 | 206-6000 | PINION SPROCKET |
| 8 | 1 | 206A-6000-01 | BEARING CAP WITH ENCODER MOUNT |
| 9 | 1 | 206A-6000 | BEARING CAP |
| 10 | 2 | 206B-6000 | SPROCKET SHAFT SPACER |
| 11 | 1 | 207-6000 | HIGH PINION GEAR |
| 12 | 1 | 208-6000 | LOW PINION GEAR |
| 13 | 1 | 40034 | PLATE ENCODER MOUNT |
| 14 | 1 | 51031 | ENCODER COUPLING MOUNT |
| 15 | 2 | 5309-M | 45mm DOBLE ROW ANGULAR CONTACT |
| 16 | 1 | 82113 | ENCODER COUPLING |

Illustration 7.11: 206-6000-1 Pinion Sprocket Assembly

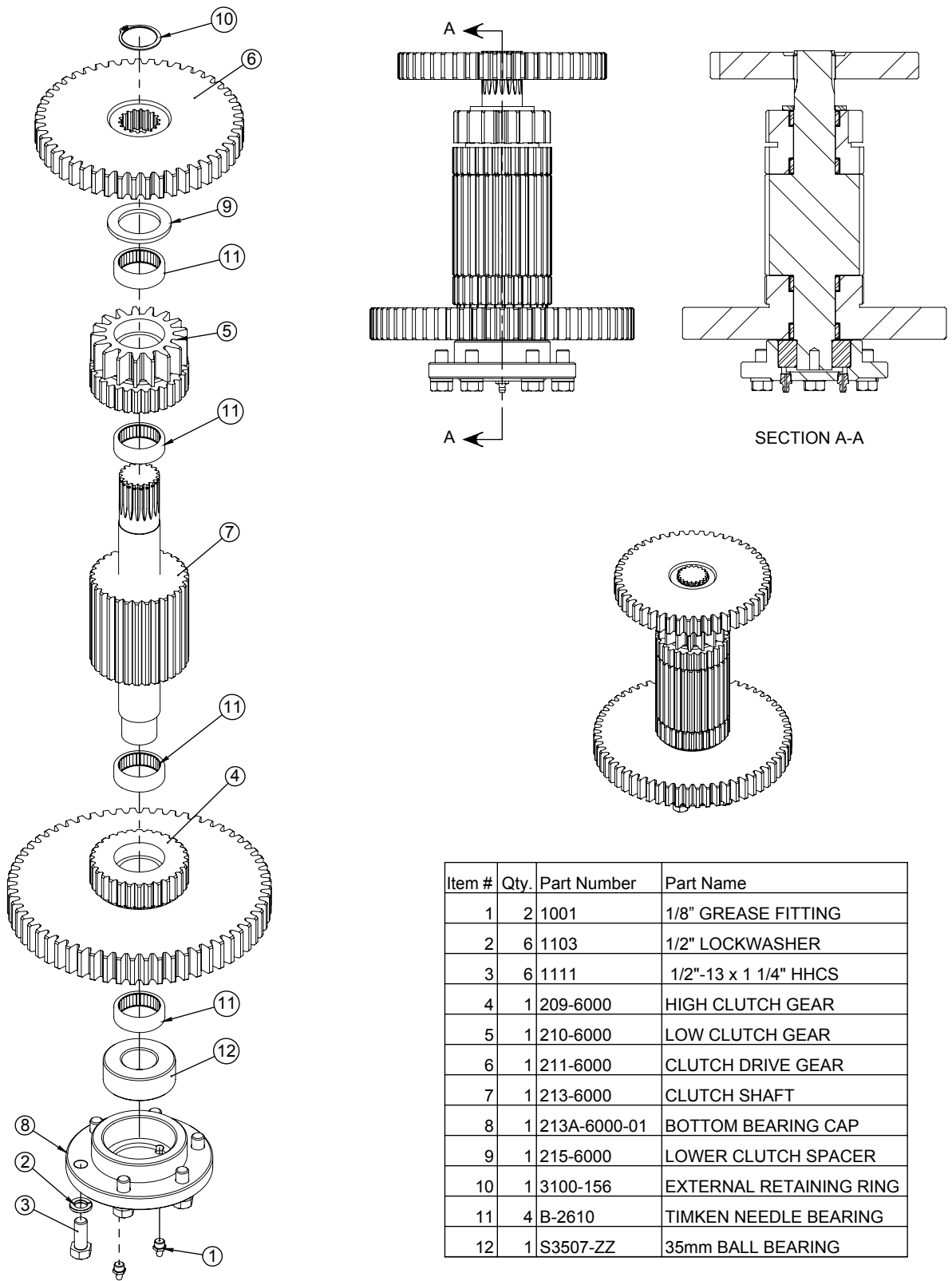

| Item # | Qty. | Part Number | Part Name |
|--------|------|--------------|-------------------------|
| 1 | 2 | 1001 | 1/8" GREASE FITTING |
| 2 | 6 | 1103 | 1/2" LOCKWASHER |
| 3 | 6 | 1111 | 1/2"-13 x 1 1/4" HHCS |
| 4 | 1 | 209-6000 | HIGH CLUTCH GEAR |
| 5 | 1 | 210-6000 | LOW CLUTCH GEAR |
| 6 | 1 | 211-6000 | CLUTCH DRIVE GEAR |
| 7 | 1 | 213-6000 | CLUTCH SHAFT |
| 8 | 1 | 213A-6000-01 | BOTTOM BEARING CAP |
| 9 | 1 | 215-6000 | LOWER CLUTCH SPACER |
| 10 | 1 | 3100-156 | EXTERNAL RETAINING RING |
| 11 | 4 | B-2610 | TIMKEN NEEDLE BEARING |
| 12 | 1 | S3507-ZZ | 35mm BALL BEARING |

Illustration 7.12: 213-6000-1 Clutch Gear Assembly

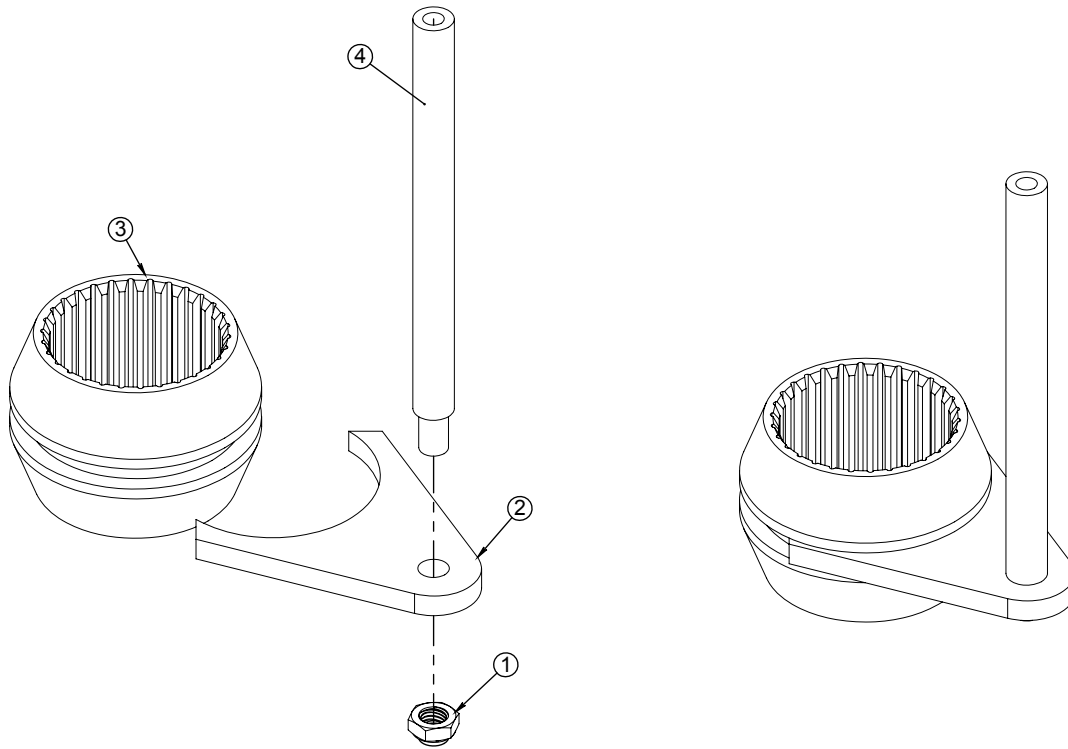

| Item # | Qty. | Part Number | Part Name |
|--------|------|-------------|-------------------------|
| 1 | 1 | 91342A | THIN NYLOCK NUT 5/8"-11 |
| 2 | 1 | 219-6000 | SHIFTING YOKE |
| 3 | 1 | 220-6000 | SHIFTING COLLAR |
| 4 | 1 | 221-6000 | SHIFTING SHAFT |

Illustration 7.13: 220-6000-1 Shifter Assembly

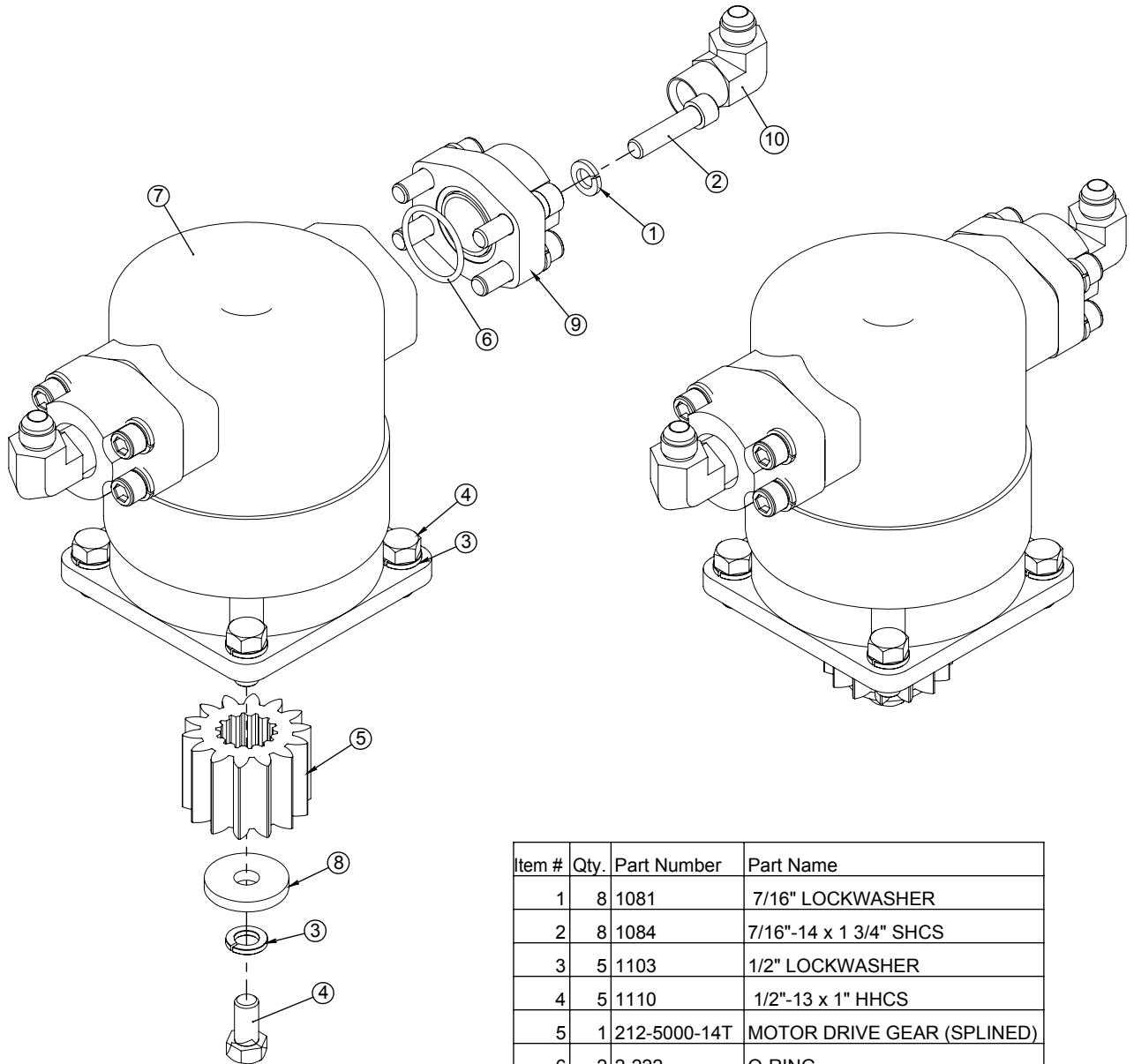

| Item # | Qty. | Part Number | Part Name |
|--------|------|--------------|----------------------------|
| 1 | 8 | 1081 | 7/16" LOCKWASHER |
| 2 | 8 | 1084 | 7/16"-14 x 1 3/4" SHCS |
| 3 | 5 | 1103 | 1/2" LOCKWASHER |
| 4 | 5 | 1110 | 1/2"-13 x 1" HHCS |
| 5 | 1 | 212-5000-14T | MOTOR DRIVE GEAR (SPLINED) |
| 6 | 2 | 2-222 | O-RING |
| 7 | 1 | 235-6500 | 1 SPEED 15 cu.inch MOTOR |
| 8 | 1 | 235A-6500 | MOTOR DRIVE GEAR RETAINER |
| 9 | 2 | W43-12-20U | 1-1/4" FLANGE |
| 10 | 2 | 8-12 CTX | 1/2" MJIC X 3/4" MNPT 90 |

Illustration 7.14: 235-6000-1 Drive Gear Assembly

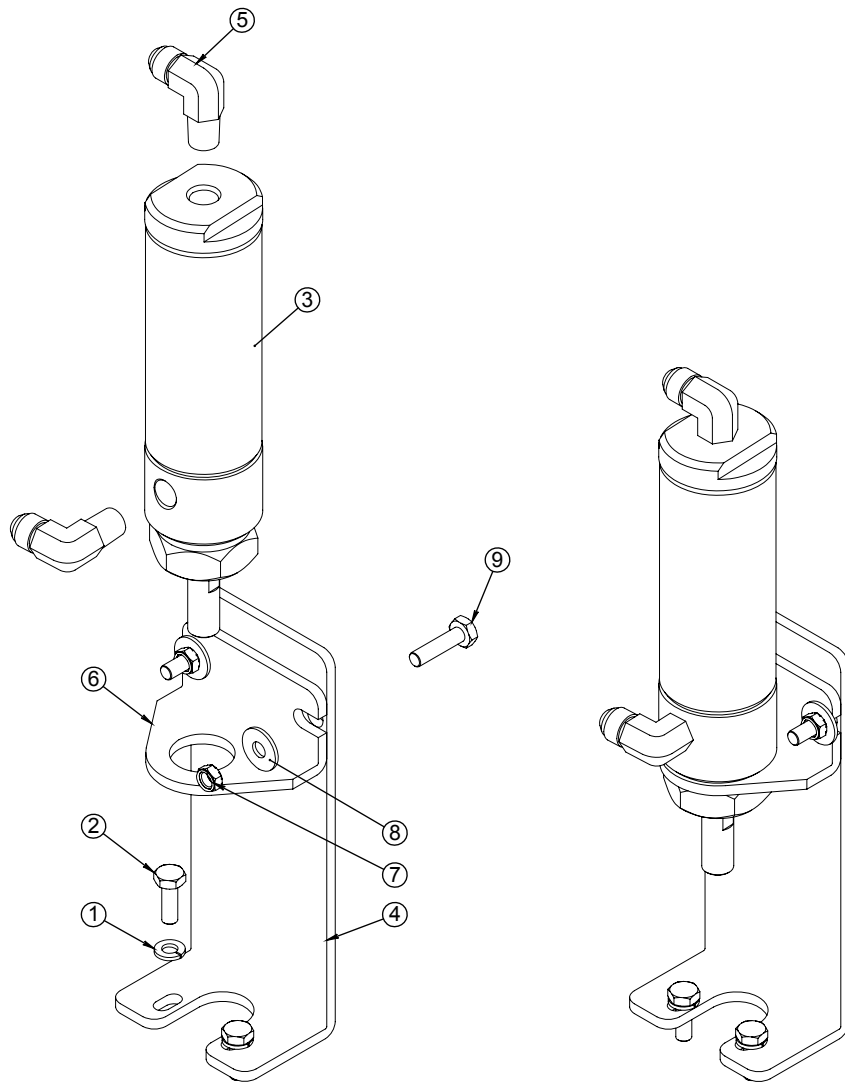

| Item # | Qty. | Part Number | Part Name |
|--------|------|-------------|----------------------------------|
| 1 | 2 | 101 | 1/4" LOCKWASHER |
| 2 | 2 | 104 | 1/4"-20 X 1 1/4" HHCS GR8 |
| 3 | 1 | 234-6000 | SHIFTING CYLINDER |
| 4 | 1 | 239-6000 | CYLINDER MOUNT BRACKET |
| 5 | 2 | 6 CTX | 1/4" MNPT X 3/8" MJIC MALE ELBOW |
| 6 | 1 | M117008 | 1-3/4" MOUNTING BRACKET |
| 7 | 2 | 212 | 1/4-20 NYLOCK NUT |
| 8 | 2 | 1008-B2 | 1/4" FLATWASHER |
| 9 | 2 | 105 | 1/4"-20 X 1" HHCS GR8 |

Illustration 7.15: 239-6000-1 Shift Cylinder Mount Assembly

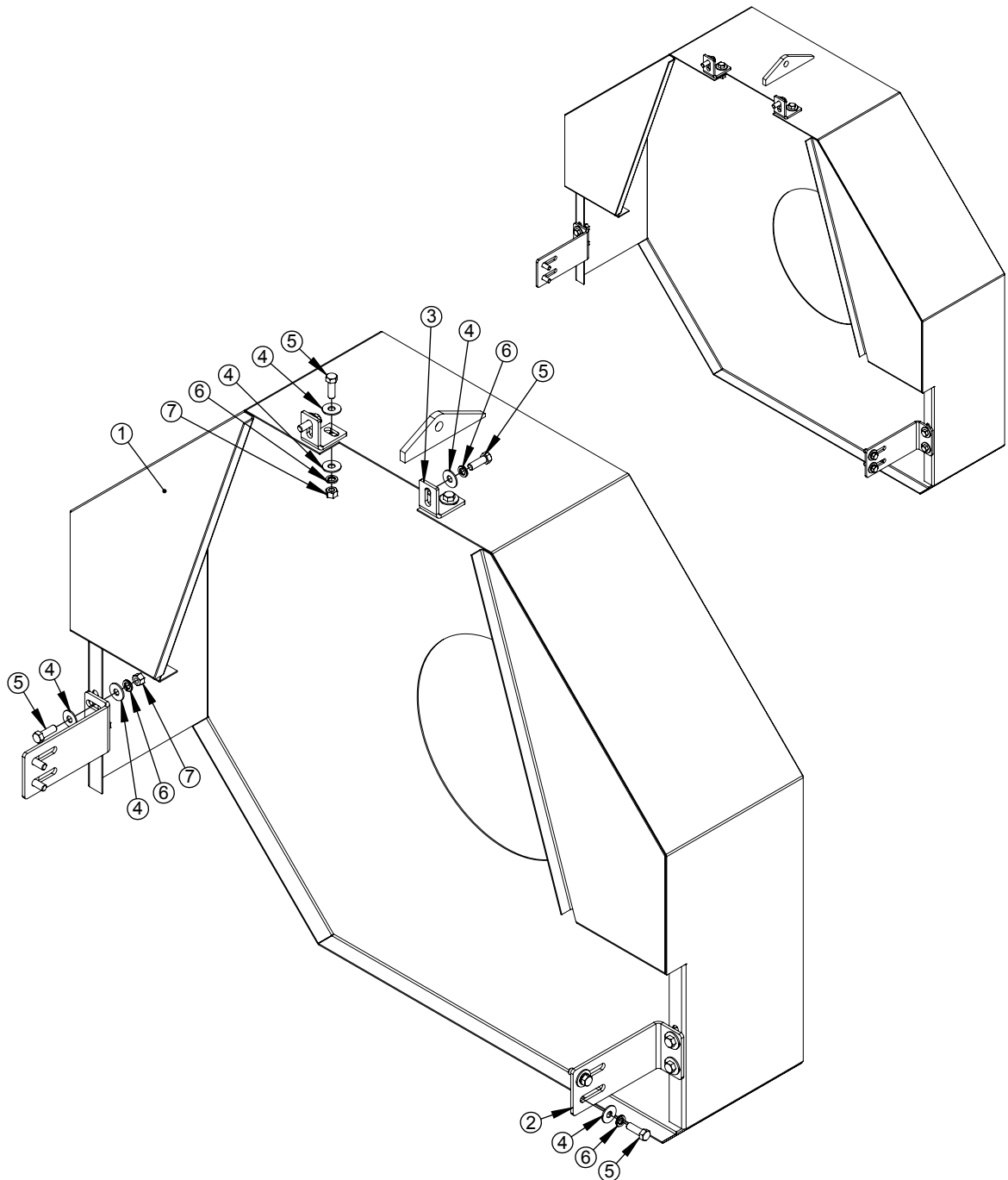

| ITEM | QTY | P/N | DESCRIPTION |
|------|-----|--------------|----------------------------------|
| 1 | 1 | 3100-6500-03 | 16" ROTATING HEAD GUARD WELDMENT |
| 2 | 2 | 3110-6500 | RP6000 COVER MOUNT ANGLE |
| 3 | 2 | 3111-6500 | TOP COVER ANGLE BRACKET |
| 4 | 18 | 1102 | FLATWASHER 1/2" GR8 |
| 5 | 12 | 1112 | HHCS 1/2"-13 X 1 1/2" GR8 |
| 6 | 12 | 1103 | LOCKWASHER 1/2" GR8 |
| 7 | 6 | 1101 | NUT HEX 1/2-13 GR8 |

Illustration 7.16: 3000-6500-03 16.5in Rotating Head Guard Assembly

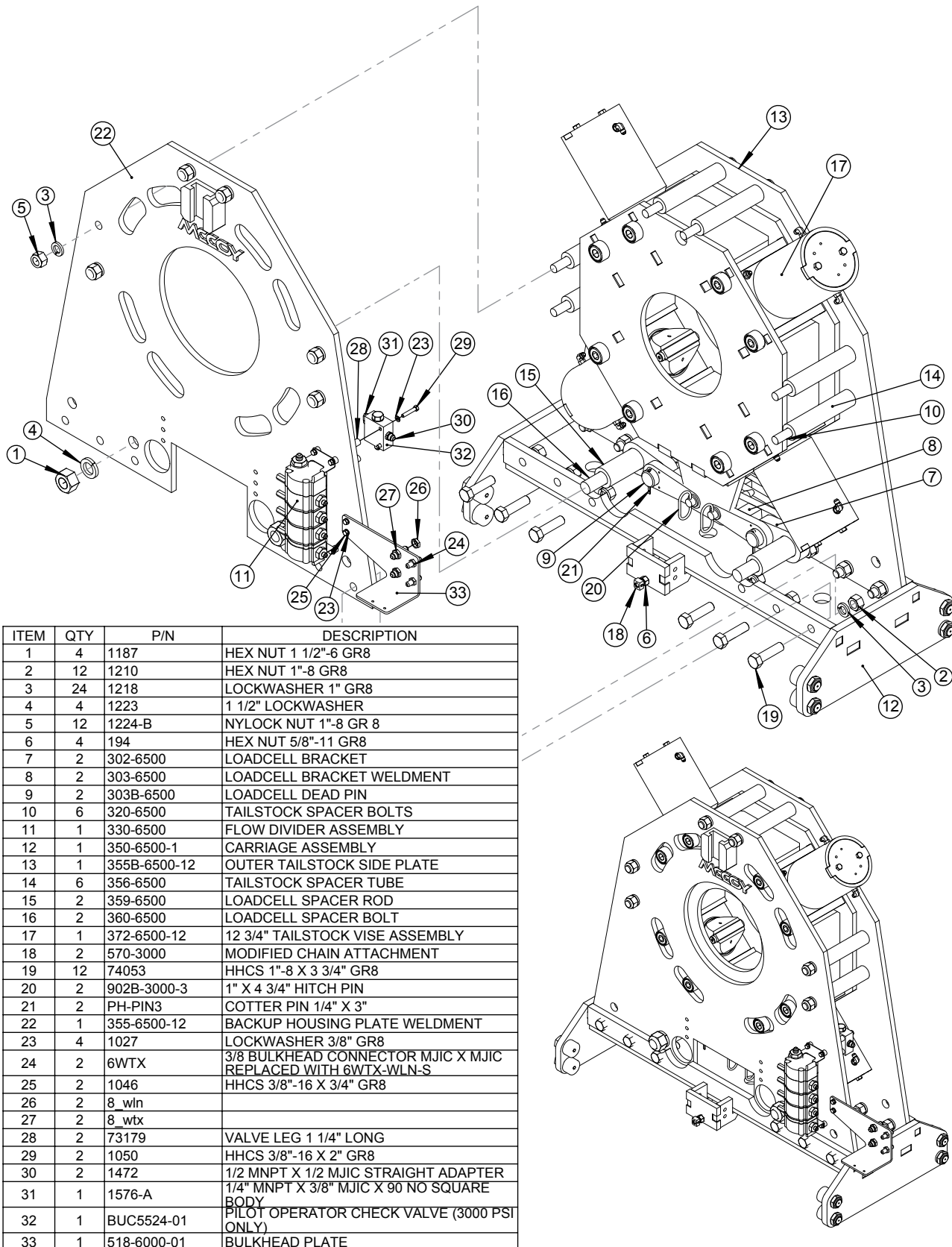

| ITEM | QTY | P/N | DESCRIPTION |
|------|-----|--------------|---|
| 1 | 4 | 1187 | HEX NUT 1 1/2"-6 GR8 |
| 2 | 12 | 1210 | HEX NUT 1"-8 GR8 |
| 3 | 24 | 1218 | LOCKWASHER 1" GR8 |
| 4 | 4 | 1223 | 1 1/2" LOCKWASHER |
| 5 | 12 | 1224-B | NYLOCK NUT 1"-8 GR 8 |
| 6 | 4 | 194 | HEX NUT 5/8"-11 GR8 |
| 7 | 2 | 302-6500 | LOADCELL BRACKET |
| 8 | 2 | 303-6500 | LOADCELL BRACKET WELDMENT |
| 9 | 2 | 303B-6500 | LOADCELL DEAD PIN |
| 10 | 6 | 320-6500 | TAILSTOCK SPACER BOLTS |
| 11 | 1 | 330-6500 | FLOW DIVIDER ASSEMBLY |
| 12 | 1 | 350-6500-1 | CARRIAGE ASSEMBLY |
| 13 | 1 | 355B-6500-12 | OUTER TAILSTOCK SIDE PLATE |
| 14 | 6 | 356-6500 | TAILSTOCK SPACER TUBE |
| 15 | 2 | 359-6500 | LOADCELL SPACER ROD |
| 16 | 2 | 360-6500 | LOADCELL SPACER BOLT |
| 17 | 1 | 372-6500-12 | 12 3/4" TAILSTOCK VISE ASSEMBLY |
| 18 | 2 | 570-3000 | MODIFIED CHAIN ATTACHMENT |
| 19 | 12 | 74053 | HHCS 1"-8 X 3 3/4" GR8 |
| 20 | 2 | 902B-3000-3 | 1" X 4 3/4" HITCH PIN |
| 21 | 2 | PH-PIN3 | COTTER PIN 1/4" X 3" |
| 22 | 1 | 355-6500-12 | BACKUP HOUSING PLATE WELDMENT |
| 23 | 4 | 1027 | LOCKWASHER 3/8" GR8 |
| 24 | 2 | 6WTX | 3/8 BULKHEAD CONNECTOR MJIC X MJIC REPLACED WITH 6WTX-WLN-S |
| 25 | 2 | 1046 | HHCS 3/8"-16 X 3/4" GR8 |
| 26 | 2 | 8_wln | |
| 27 | 2 | 8_wtx | |
| 28 | 2 | 73179 | VALVE LEG 1 1/4" LONG |
| 29 | 2 | 1050 | HHCS 3/8"-16 X 2" GR8 |
| 30 | 2 | 1472 | 1/2 MNPT X 1/2 MJIC STRAIGHT ADAPTER |
| 31 | 1 | 1576-A | 1/4" MNPT X 3/8" MJIC X 90 NO SQUARE BODY |
| 32 | 1 | BUC5524-01 | PILOT OPERATOR CHECK VALVE (3000 PSI ONLY) |
| 33 | 1 | 518-6000-01 | BULKHEAD PLATE |

Illustration 7.17: 300-6500-12 12.75in Backup Assembly

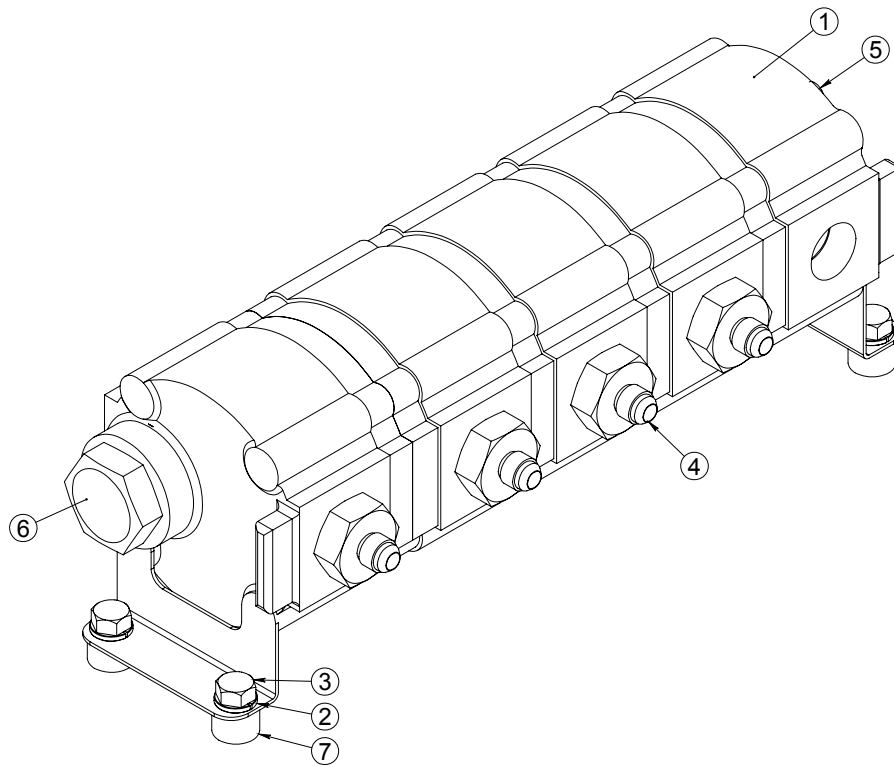

| Item # | Qty. | Part Number | Part Name |
|--------|------|--------------|------------------------|
| 1 | 1 | 1001-S1-6500 | DELTA FLOW DIVIDER |
| 2 | 4 | 1027 | WASHER, LOCK 3/8" |
| 3 | 4 | 1046 | HHCS 3/8-16 X 3/4 |
| 4 | 4 | 6-12 f5ox-s | 3/8" MJIC X 3/4" ORING |
| 5 | 1 | 8-16 F5OX-S | 1/2" MJIC X 1" ORING |
| 6 | 1 | 16_p5on-s | 1" M ORING PLUG |
| 7 | 4 | BUC4085-S7 | VALVE LEG |

Illustration 7.18: 330-6500 Delta Power 6 Port Flow Divider

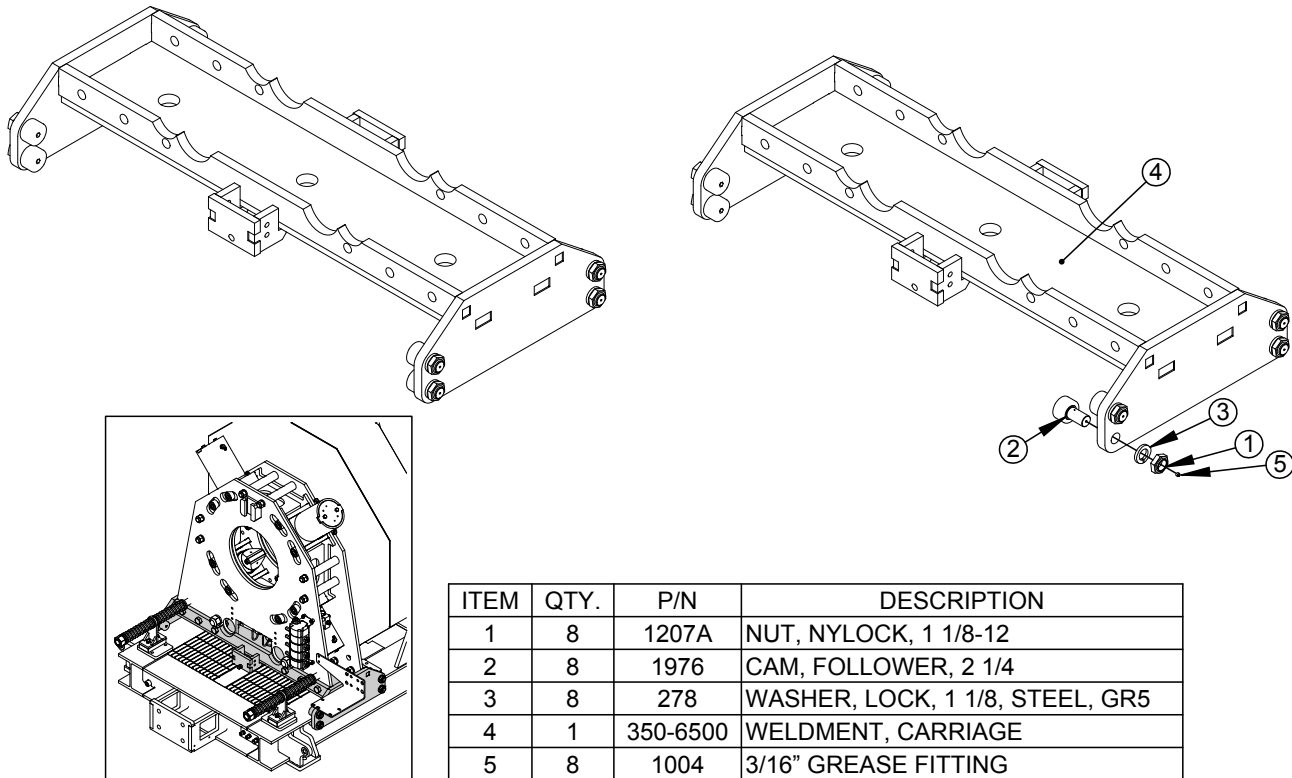
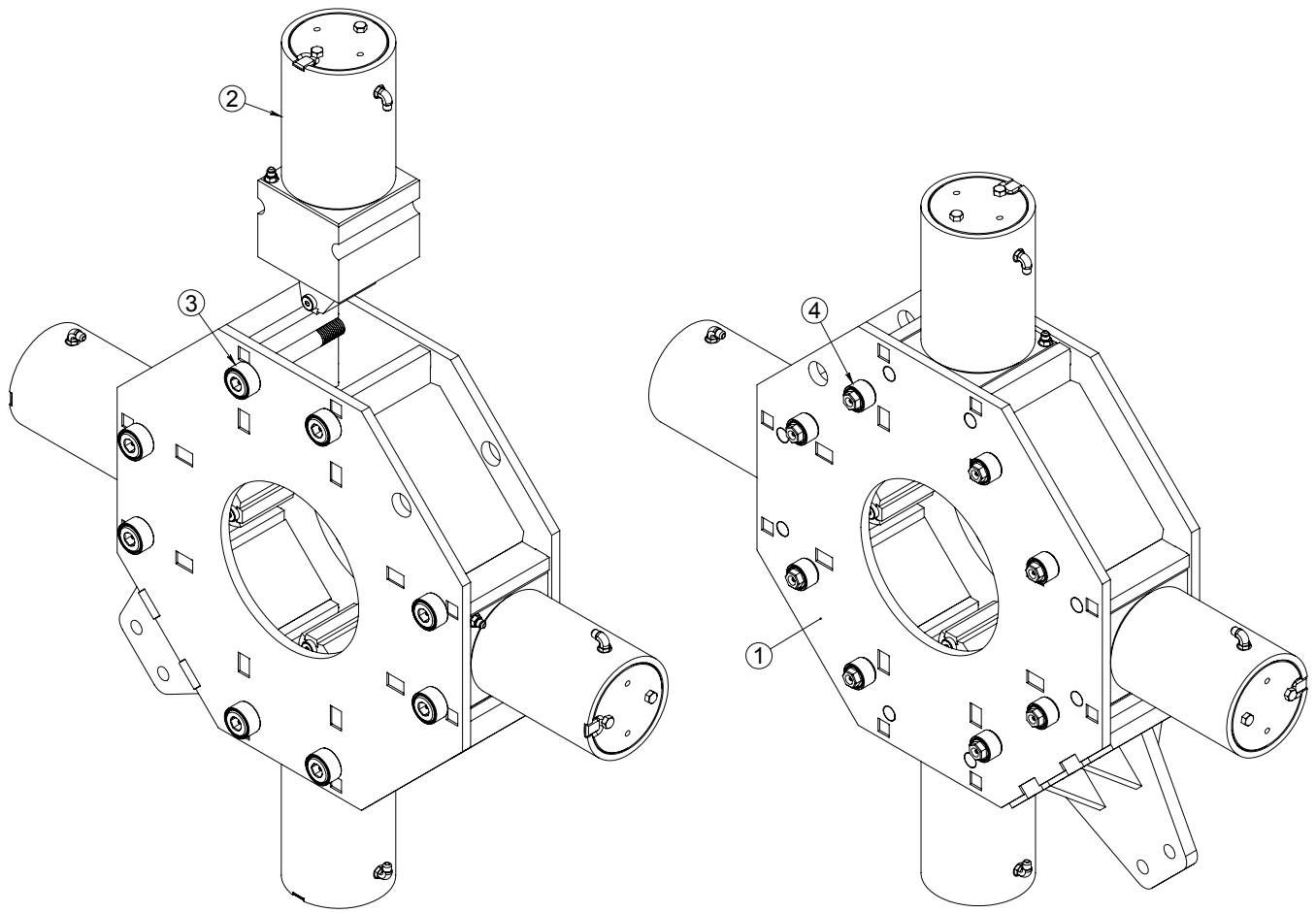
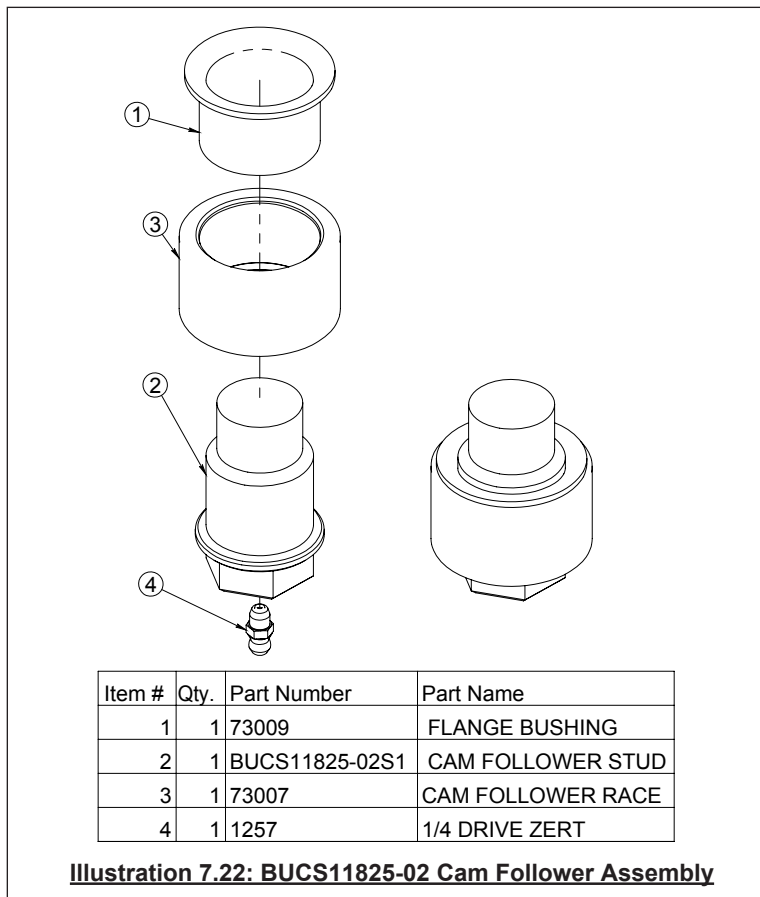
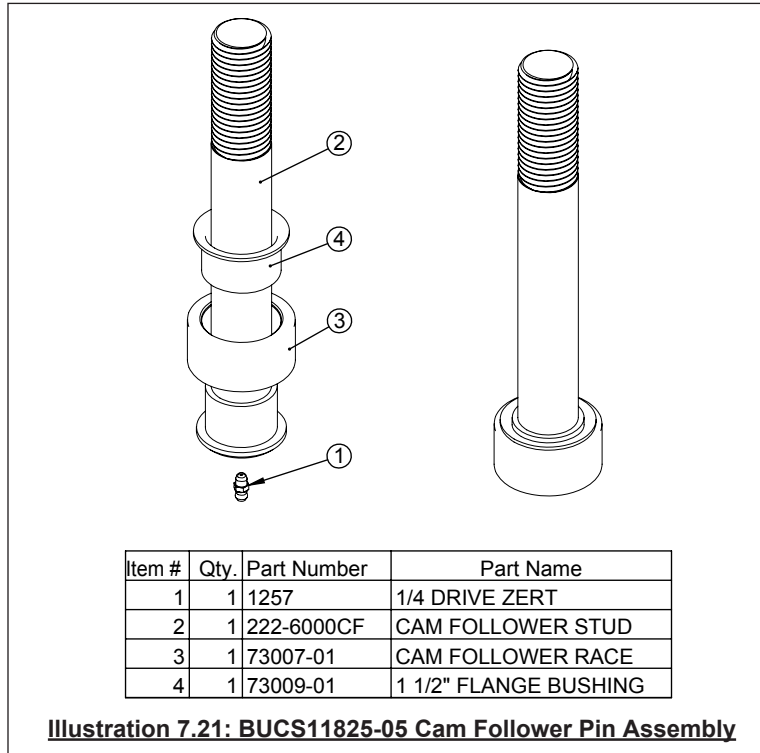

Illustration 7.19: 350-6500-1 Carriage Assembly



| Item # | Qty. | Part Number | Part Name |
|--------|------|--------------|------------------------------|
| 1 | 1 | 351-6500-12 | TAILSTOCK HEAD WELDMENT |
| 2 | 4 | 400-3000-1 | CLAMP CYLINDER ASSEMBLY |
| 3 | 8 | BUCS11825-05 | 9" CAM FOLLOWER PIN ASSEMBLY |
| 4 | 8 | BUCS11825-02 | CAM FOLLOWER ASSEMBLY |

Illustration 7.20: 372-6500-12 11.75 Backup Vise Assembly



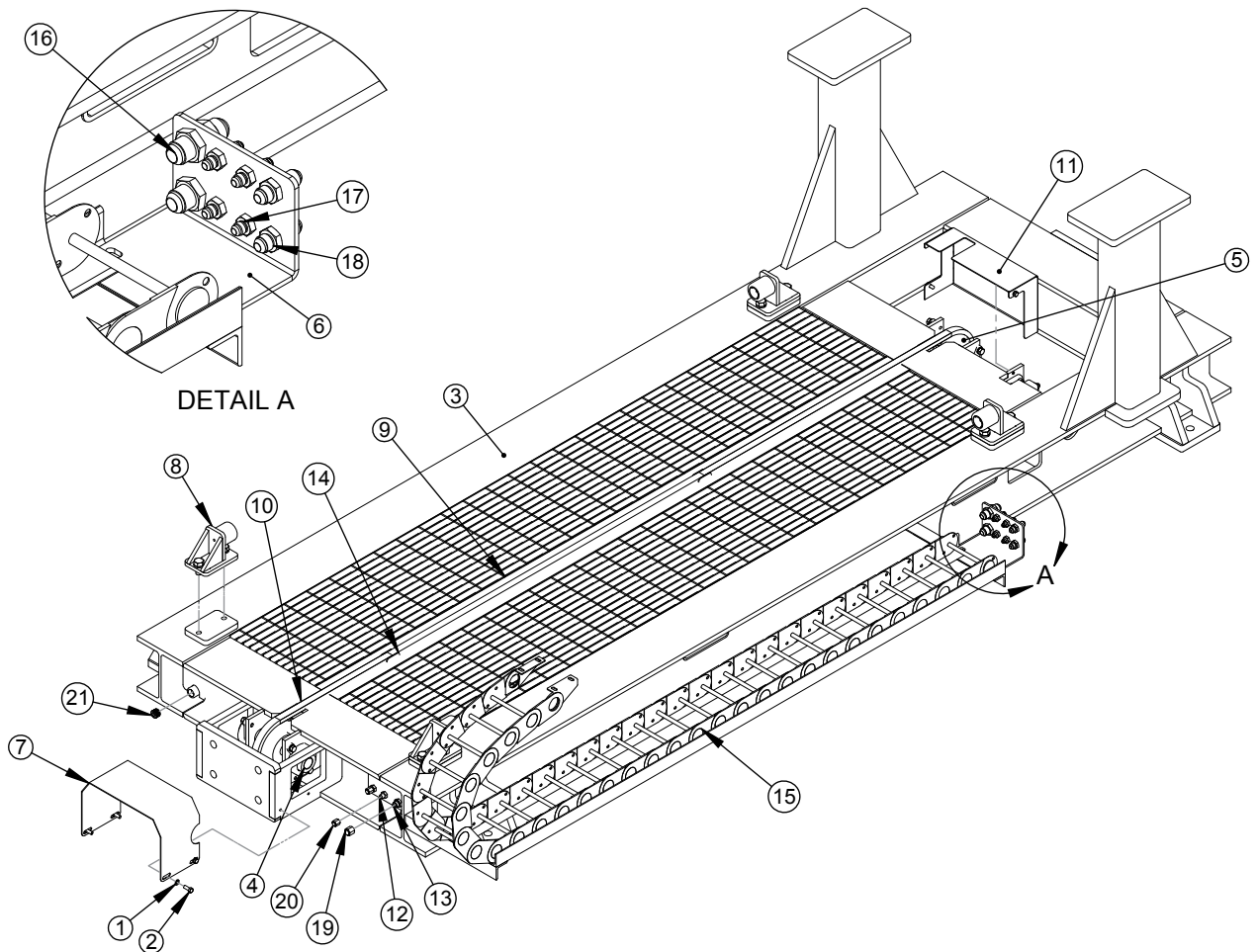

| ITEM | QTY | P/N | DESCRIPTION |
|------|-----|--------------|---|
| 1 | 4 | 1027 | LOCKWASHER 3/8" GR8 |
| 2 | 4 | 1047 | HHCS 3/8"-16 X 1" GR8 |
| 3 | 1 | 500A-6012-12 | 12 FOOT SKID WELDMENT F/ RP6012 |
| 4 | 1 | 508-3000-1 | IDLER SPROCKET ASSEMBLY |
| 5 | 1 | 509-3000-1 | DRIVE SPROCKET ASSEMBLY |
| 6 | 1 | 1000417 | FIXED BULKHEAD PLATE |
| 7 | 1 | 530-3500 | SPROCKET COVER |
| 8 | 4 | 540-3000 | BUMPER STOP ASSEMBLY |
| 9 | 2 | 552A-6516-12 | LONG GRATING |
| 10 | 3 | 556-7000 | 10' TRAVEL CHAIN |
| 11 | 1 | 571-6500-1 | SPROCKET COVER ASSEMBLY |
| 12 | 8 | 6WTX | 3/8 BULKHEAD CONNECTOR MJIC X MJIC REPLACED WITH 6WTX-WLN-S |
| 13 | 4 | 8WTX-S | 1/2" MJIC BULKHEAD FITTING |
| 14 | 2 | 80CL | LINK, MASTER SAME AS 527A-6500 |
| 15 | 1 | 550A-3000 | HOSE TRAX 10 FT. LONG |
| 16 | 2 | 12-WTX-WLN-S | FITTING BULKHEAD 3/4 INCH MJIC X MJIC |
| 17 | 4 | 6WTX-WLN-S | 3/8 MJIC X 3/8 MJIC BULKHEAD CONNECTOR WITH LOCK NUT |
| 18 | 2 | 8WTX-WLN-S | 1/2" MJIC X 1/2" MJIC BULKHEAD FITTING |
| 19 | 4 | 1637 | 1/2" JIC CAP |
| 20 | 8 | 1636 | 3/8 JIC CAP |
| 21 | 2 | 1610 | FLUSH PLUG 3/4 NPT |

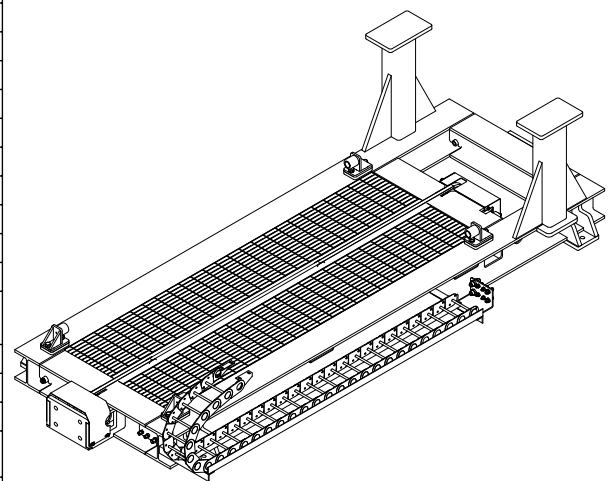
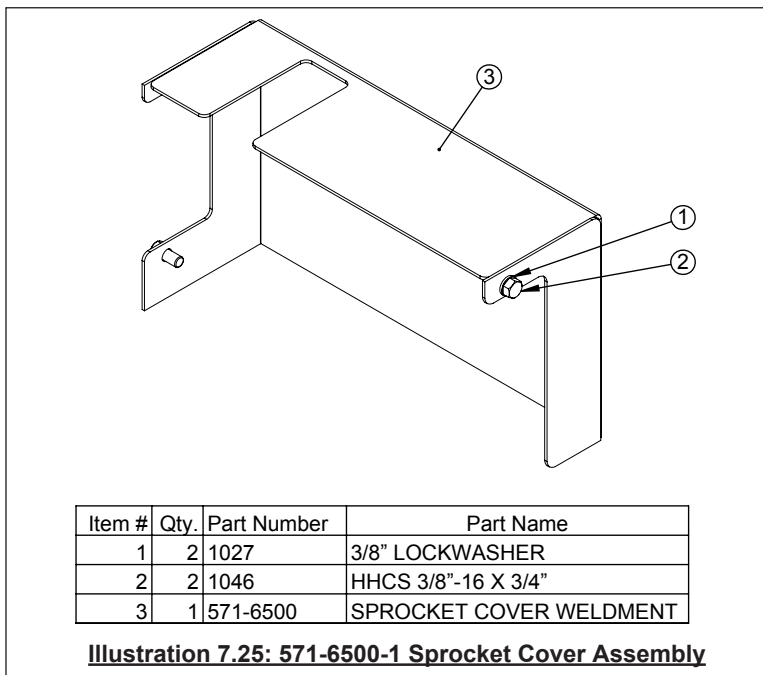
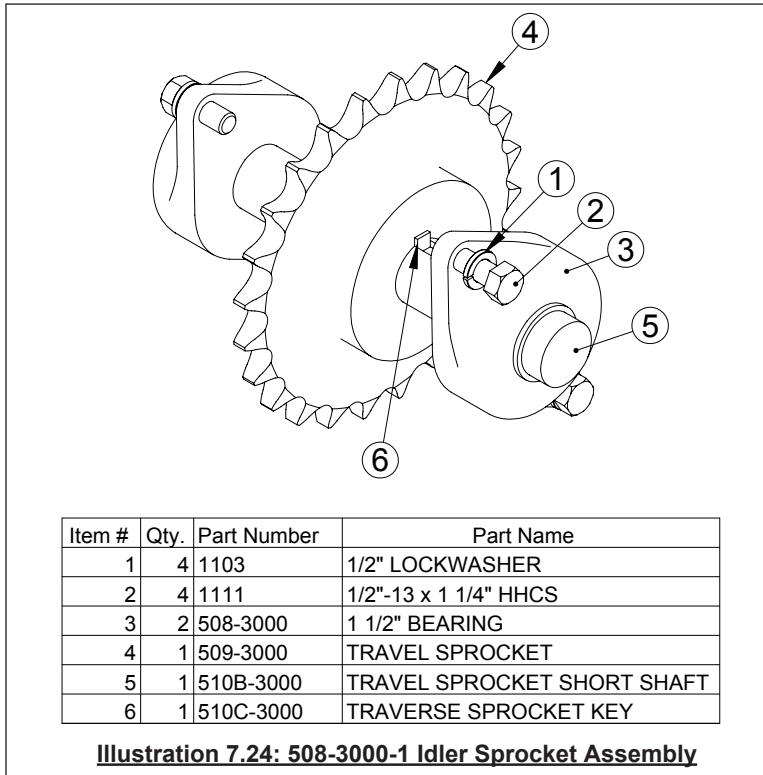
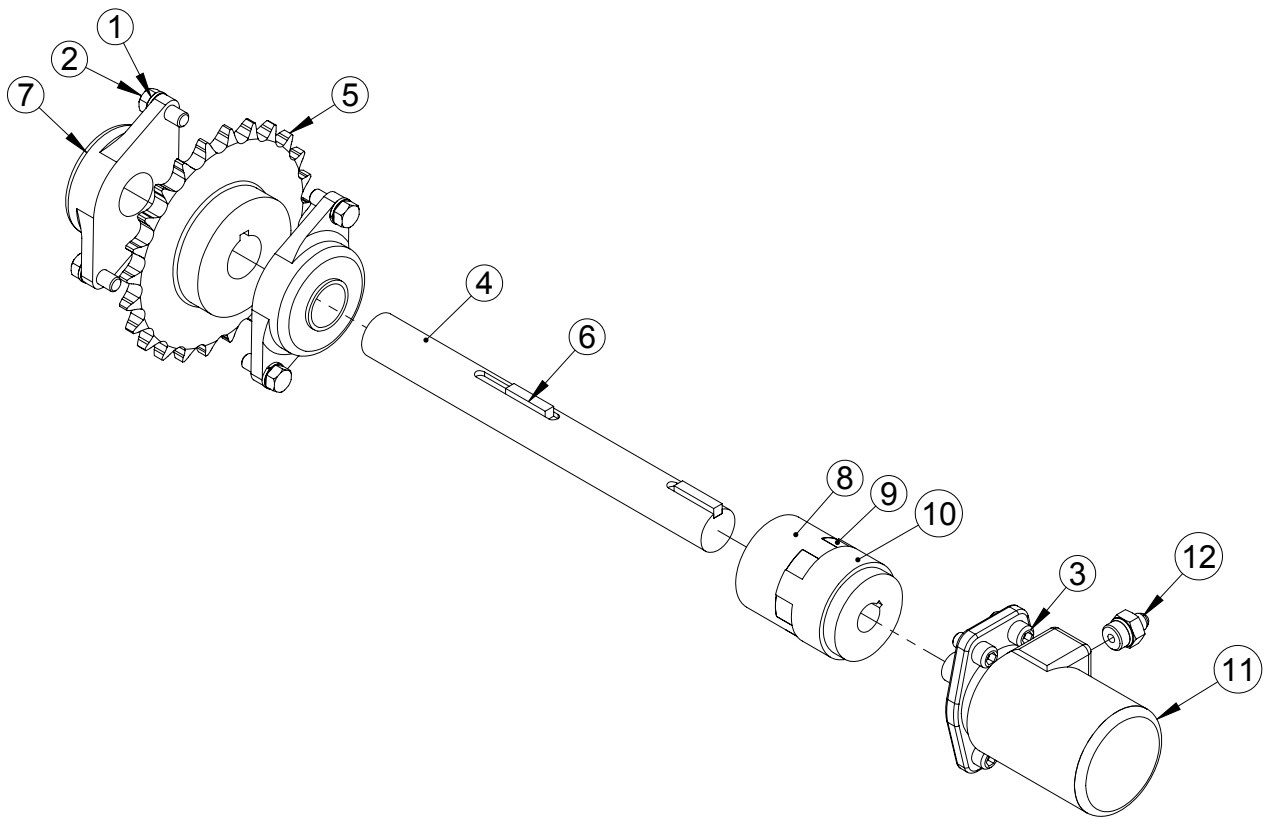

Illustration 7.23: 500-6012-12 12ft Skid Assembly





| Item # | Qty. | Part Number | Part Name |
|--------|------|-------------|------------------------|
| 1 | 4 | 1103 | 1/2" LOCKWASHER |
| 2 | 4 | 1111 | 1/2"-13 x 1 1/4" HHCS |
| 3 | 4 | 246 | 1/2-13 x 1 SHCS |
| 4 | 1 | 502B-6500 | TRAVEL SPROCKET SHAFT |
| 5 | 1 | 509-3000 | TRAVEL SPROCKET |
| 6 | 2 | 510C-3000 | TRAVERSE SPROCKET KEY |
| 7 | 2 | 508-3000 | 1 1/2" BEARING |
| 8 | 1 | 515A-3000 | 1 1/2" L-COUPLING |
| 9 | 1 | 515C-3000 | L110 SPIDER |
| 10 | 1 | 515B-3000 | MODIFIED 1" L- COPLING |
| 11 | 1 | 511-6500 | TRAVEL MOTOR |
| 12 | 2 | 6-10_f5ox-s | 5/8" ORING X 3/8" MJIC |

Illustration 7.26: 509-3000-1 Drive Sprocket Assembly

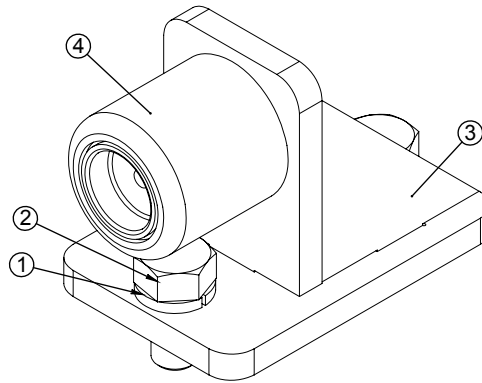

| Item # | Qty. | Part Number | Part Name |
|--------|------|-------------|-----------------------|
| 1 | 2 | 1171 | 3/4" LOCKWASHER |
| 2 | 2 | 1201 | HHCS 3/4"-10 X 1 1/2" |
| 3 | 1 | 525-3000-1 | BUMPER STOP WELDMENT |
| 4 | 1 | 528-3000 | BUMPER STOP |

Illustration 7.27: 540-3000 Bumper Stop Assembly



**This page intentionally
left blank**



SECTION 8: TORQUE/TURNS MANAGEMENT



**This page intentionally
left blank**

8.0 TORQUE MEASUREMENT

This bucking unit is designed to be used in conjunction with a torque turn management system such as WINCATT® for connection data acquisition.

Please refer to the WINCATT® manual for further instruction.

8.1 PERIODIC LOAD CELL INSPECTION AND MAINTENANCE

NOTICE

ONLY QUALIFIED, DESIGNATED PERSONNEL ARE PERMITTED TO PERFORM MAINTENANCE ON ANY COMPONENT OF THE TORQUE MEASUREMENT SYSTEM.

8.1.1 Inspection

The torque measurement system supplied with your equipment is designed and built to provide years of trouble-free service with minimum maintenance. Periodic inspections of the load cell, fittings, and associated cables are recommended in order to keep the system in top operating condition. A thorough inspection should be made at each rig-up.

NOTICE

LOAD CELLS ARE NOT USER SERVICEABLE. DAMAGED TORQUE MEASUREMENT COMPONENTS MUST BE RETURNED TO THE FACTORY FOR REPAIR AND RECALIBRATION.



**This page intentionally
left blank**



SECTION 9: OEM DOCUMENTATION

The manufacturer information contained in this section has been obtained from publicly available web sites and has been provided for information purposes only. McCoy Global does not guarantee the accuracy of the information contained in this section. All original copyrights claimed by the manufacturer(s) apply.



**This page intentionally
left blank**

9.0 OEM DOCUMENTATION LINKS

Rineer Hydraulic Motors:

http://dc-america.resource.bosch.com/media/us/products_13/product_groups_1/industrial_hydraulics_5/pdfs_4/ra10551.pdf