

4X BACKUP MOUNTING POSITIONS

REVISIONS				
REV.	ECO NUMBER	ECO DESCRIPTION	ECO COMPLETED BY	ECO COMPLETED DATE
6	002397	ADDED RUBBER PAD GUARD	s. yuan	03/09/2015
A	ECN-002616	REMOVED 10-0008C(X1), 4IN_GAUGE(X1) FIXED HEXBOLT PART NUMBER	S. PANCHAL	05/18/2016
B	ECN17-0176	ADDED MISSING GAUGE MOUNT FASTENERS	T.YIMER	08/07/2017
C	N/A	REMOVE TABLE	J. KELLY	1/26/2018

UNLESS OTHERWISE SPECIFIED:		PROPRIETARY STATEMENT			
1. DIMENSIONS ARE IN INCHES 2. TOLERANCES: ANGULAR ± 1° FRACTIONAL ± 1/16 TWO PLACE DECIMAL ± 0.02 THREE PLACE DECIMAL ± 0.005 3. IDENTIFY P/N & MAIL P.O. USING 1/8 TO 1/4 ETCHED LETTERS, DENOTED BY "X" 4. REMOVE BURRS & SHARP EDGES WITH 1/64x45° MAX 5. MACHINED FILET RADII SHALL BE 1/32 6. FINAL SURFACE ROUGHNESS AVG. (Ra) SHALL BE ≤ 250 MICROINCHES 7. DIMENSIONS IN TRIANGLES ARE CRITICAL DIMENSIONS 8. 100% INSPECTION REQUIRED 9. A TRIANGLE DENOTES A REVISION 10. INTERPRET DRAWING PER ASME Y14.5-2009		THIS DOCUMENT IS THE PROPERTY OF MCCOY CORPORATION AND IS CONSIDERED CONFIDENTIAL. THIS INFORMATION MAY NOT BE USED, DISCLOSED, COPIED, OR REPRODUCED IN ANY FORM, WITHOUT THE EXPRESS WRITTEN CONSENT OF MCCOY CORPORATION.			
DRAWN	MRM	06/11/2010	DESCRIPTION		ASSEMBLY, TONG, 5000-8K X 5000 CAM BU, COMPRESSION
CHECKED	MCG	07/07/2010	SIZE PART NO.		
APPROVED	MCG	07/07/2010	MATERIAL		N/A
THIRD ANGLE PROJECTION			WEIGHT		
			SHEET 1 OF 2		

RELEASED FOR PRODUCTION

ITEM	QTY	A	P/N	DESCRIPTION
1	1		85-2000	ASSEMBLY, BACKUP, COMPRESSION
2	1		101-4403	WELDMENT, TORQUE GAUGE MOUNT, 5000-8K
3	2		101-3661	WELDMENT, LEG, TONG
4	1		101-4340	WELDMENT, LOAD CELL HOLDER, 5000-8K
5	2		101-4446	SPACER, PLAIN
6	2		02-0920	SPRING, COMPRESSION, 2.187 OD X 1.773 ID X 5.0 L
7	1		HITCH PIN 0.148 X 2.938	PIN, HITCH 0.148 X 2.938
8	2		02-0246	GAUGE, PRESSURE, 3000PSI, BOTTOM MOUNT
9	1		02-0023	PLATE, SERIAL NUMBER
10	1		101-4958	PLATE, NAME, FUNCTION
11	1		101-4957	PLATE, NAME, SPEED
12	2		101-4339	SPACER, SPRING
13	1		101-5131	WELDMENT, BASE, SKID
14	2		101-5806	WELDMENT, BASE, LEG
15	20		09-5106	WASHER, SPRING LOCK, REGULAR, 3/8, 17/25, 0.035-0.125, STEEL, GR 8, ZINC
16	4		09-5110	WASHER, SPRING LOCK, REGULAR, 1/2, 43/50, 0.125-0.25, STEEL, GR 8, ZINC
17	2		09-1064	BOLT, HEX, 3/8-16, 4 1/2, STEEL, GR 8, ZINC, FULLY THREADED
18	2		09-1062	BOLT, HEX, 3/8-16, 4, STEEL, GR 8, ZINC, FULLY THREADED
19	4		09-1174	BOLT, HEX, 1/2-13, 2, STEEL, GR 8, ZINC, FULLY THREADED
20	8		09-1048	BOLT, HEX, 3/8-16, 1 1/4, GR 8, ZINC, FULLY THREADED
21	4		09-5806	NUT, HEX, 3/8-16, STEEL, GR 8, ZINC, DOUBLE CHAMFER
22	4		09-9124	NUT, HEX, 1/2-13, STEEL, GR 8, ZINC
23	2		09-5806	NUT, HEX, 3/8-16, STEEL, GR 8, ZINC
24	8		09-5806	NUT, HEX, 3/8-16, STEEL, GR 8, ZINC
25	1		101-5869	ASSEMBLY, CYLINDER, DOOR
26	1		09-9179	SCREW, SHOULDER, SOCKET HEAD, 3/8, 1/2, STEEL, GR 8, ZINC
27	1		09-0123	BOLT, SHSS, 3/8 x 1-1/4
28	2		09-5124	3/8"
29	2		101-7945	WASHER, LEG, RUBBER
30	2		09-1058	BOLT, HEX, 3/8-16, 3, GR 8, ZINC, FULLY THREADED
31	1	A	80-2001-7	ASSEMBLY, TONG, 5000-8K
32	9		02-E0582	NUT, NYLOCK, 6-32
33	3	B	02-E0583	MACHINE SCREW, FLAT HEAD PHILLIP, 6-32 X 3/4 LONG
34	6	B	70-1000	SOCKET HEAD CAP SCREW, 6-32 X 1/2"

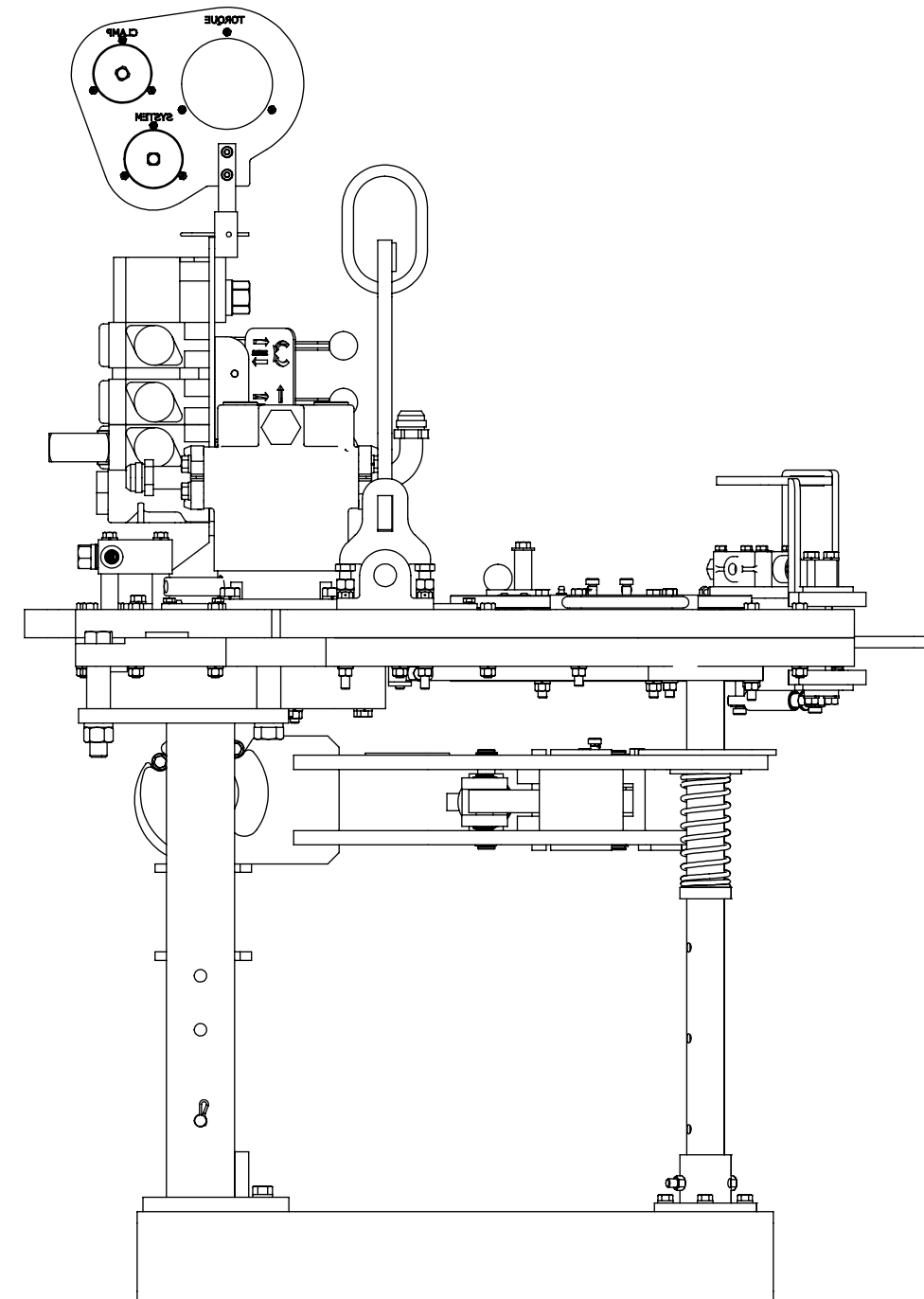
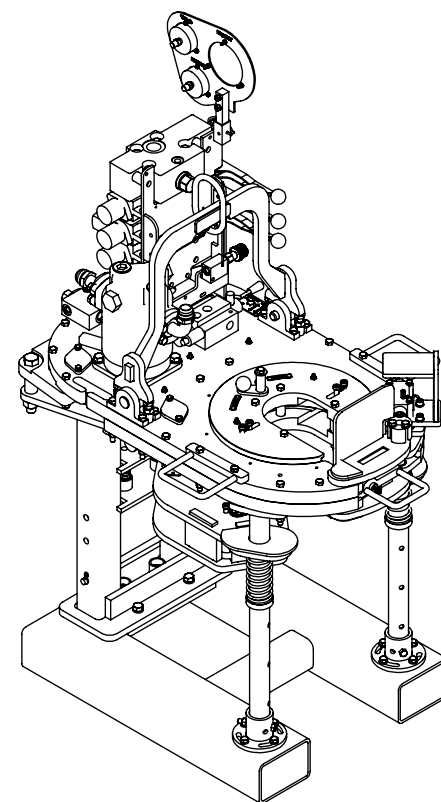

DESCRIPTION  
ASSEMBLY, TONG, 5000-8K X 5000 CAM BU, COMPRESSION

SIZE PART NO. 80-2001-8 REV C

MATERIAL N/A SHEET 2 OF 2